

ASSEMBLY INSTRUCTIONS



CAUTION

- Inspect the wire insulation for any cuts, abrasions or exposed copper that may have resulted during shipping. If there is a defect in the wire, do not attempt installation.
- Before starting installation of this fixture or removal of a previous fixture, disconnect the power by turning off the circuit breaker or by removing the fuse at the fuse box.

TOOLS REQUIRED

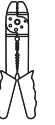
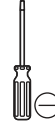
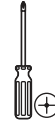

If you need further assistance, please contact us.

* PARTS SHOWN MAY DIFFER SLIGHTLY PER LIGHT FIXTURE

HARDWARE INCLUDED

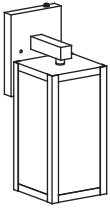

Fixture

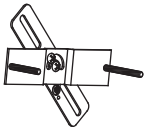

Mounting Unit



Ball Nuts



Rubber Rings



Mounting Screws



Wire Nuts

EXPLODED PARTS

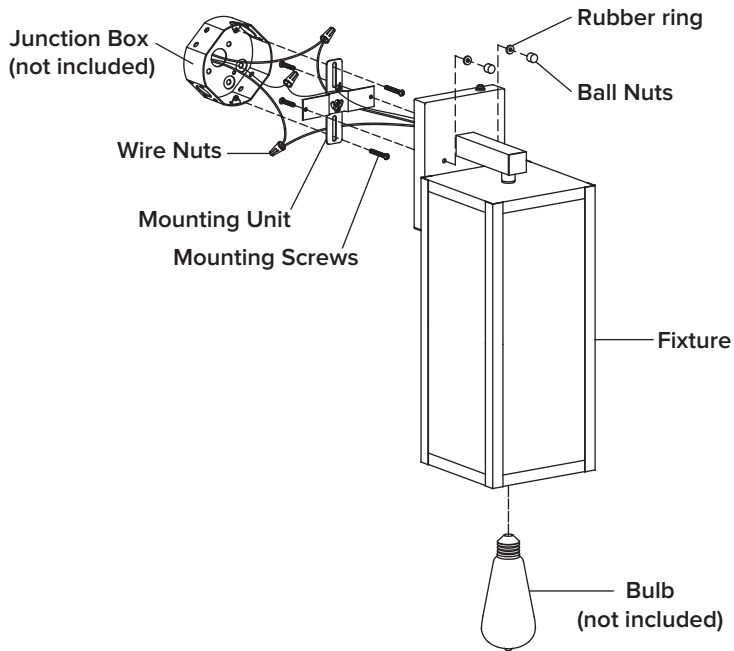

INSTALLATION

STEP 1

Unscrew the **rubber rings** and **ball nuts** from the **mounting unit**. Use the **mounting screws** to attach the **mounting unit** to the junction box (not included).

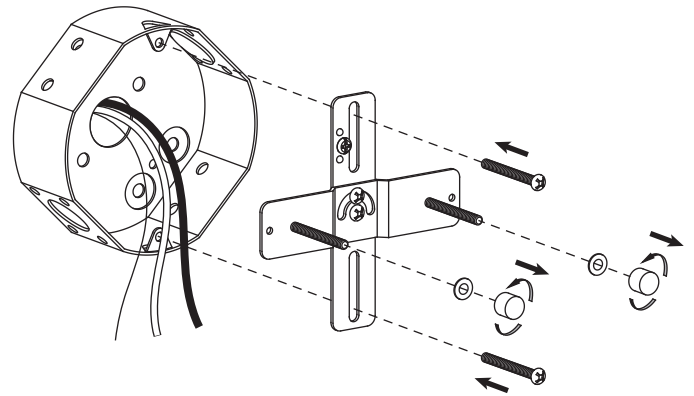

STEP 2

Make the electrical connection from the junction box (not included) to the **fixture**. Connect the ground wire to the **mounting unit** using the preinstalled green ground screw. Next, connect the live wire, neutral wire and ground wires with the supplied **wire nuts**. Secure with electrical tape.

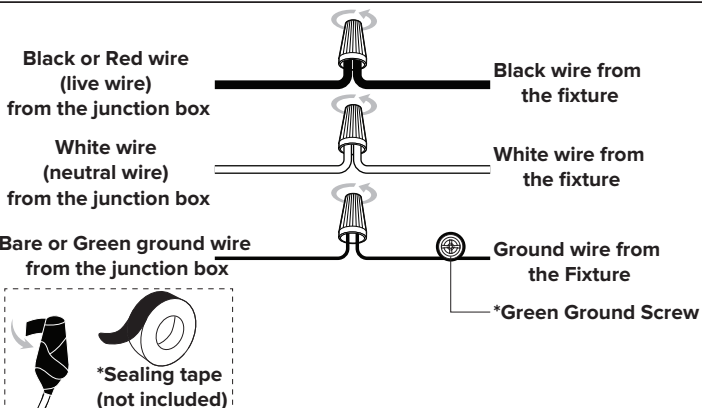
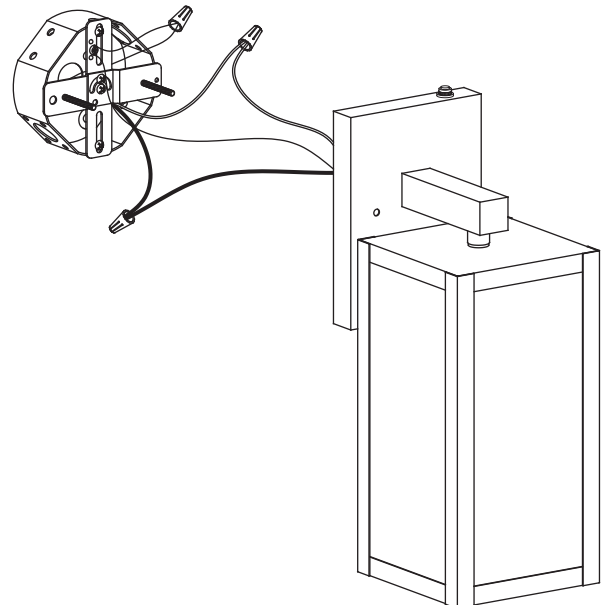

STEP 3

Attach the **fixture** to the **mounting unit** through screw holes as shown, and secure it with **rubber rings** and **ball nuts**.

NOTICE: Please use caulk in the back plate and wall mounting surface to prevent water from entering.

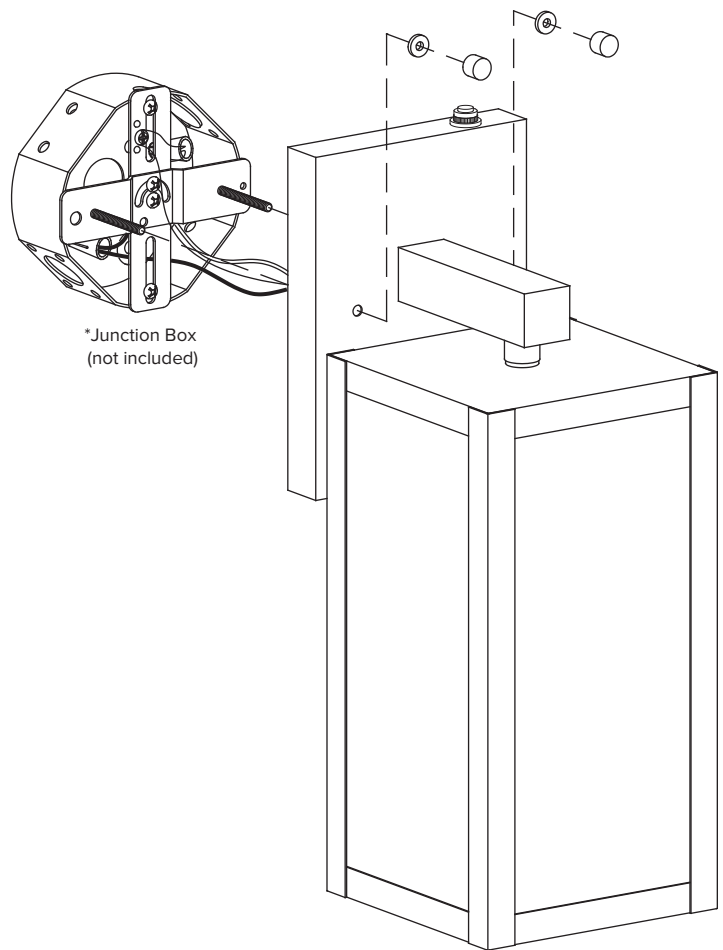

STEP 4

Install bulb (not included)

