

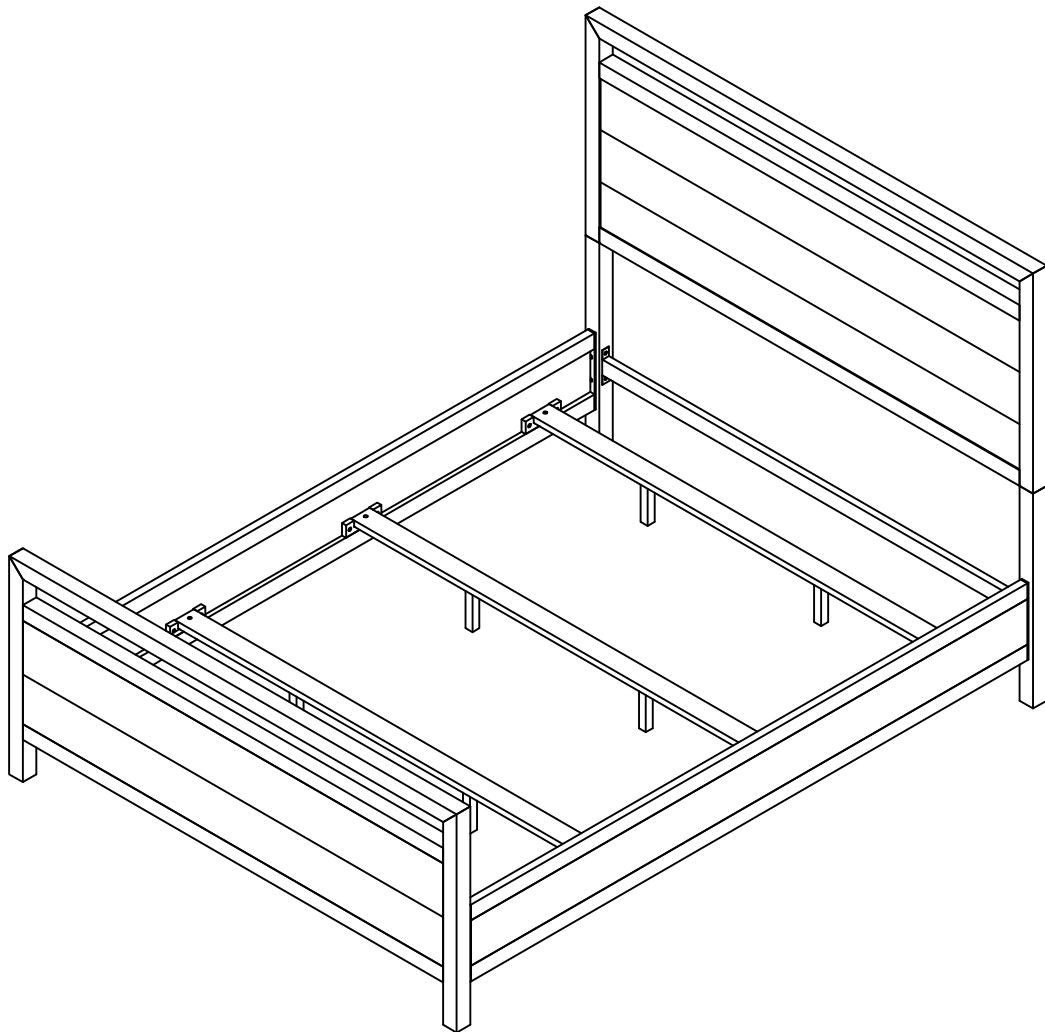

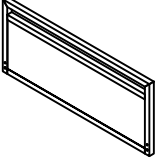

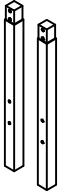

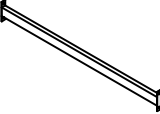
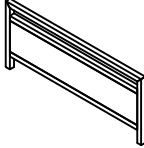
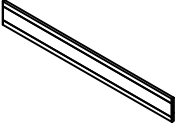
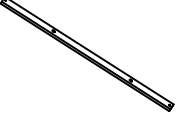

Panel Bed
CF92004

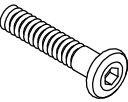

PART LIST

					
Headboard Panel 1 PC	Headboard Post 2 PCS	Headboard Bottom Rail 1 PC	Footboard Panel 1 PC	Side Rail 2 PCS	Slat 3 PCS
					
Support Leg 6 PCS					

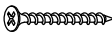
HARDWARE LIST

					
#1 1/4" X 7/8" Bolt 12 PCS (Extra 1)	#2 1/4" X Ø11 X 1.2 Spring Washer 12 PCS (Extra 1)	#3 1/4" X Ø16 X 1 Flat Washer 12 PCS (Extra 1)	#4 Ø8 X 30 Screw 6 PCS	#5 M4 X 58 X 23 Allen Wrench 1 PC	#6 M5 X 60 X 23 Large Allen Wrench 1 PC

ADDITIONAL TOOLS (Not Provided)

Note: It is not recommended to use power tools during assembly.

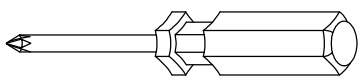

Phillips Head Screwdriver

Step 1. Lay headboard panel (part A) upside down on a soft surface, such as carpet, as shown below. Attach headboard posts (part B) to headboard panel (part A) using pre-installed bolts and large allen wrench (part #6). See Figure 1. Attach headboard bottom rail (part C) to headboard posts (part B) using bolts (part #1), spring washers (part #2), flat washers (part #3) and allen wrench (part #5). See Figure 2.

NOTE: Please do not fully tighten bolts until unit is fully assembled.

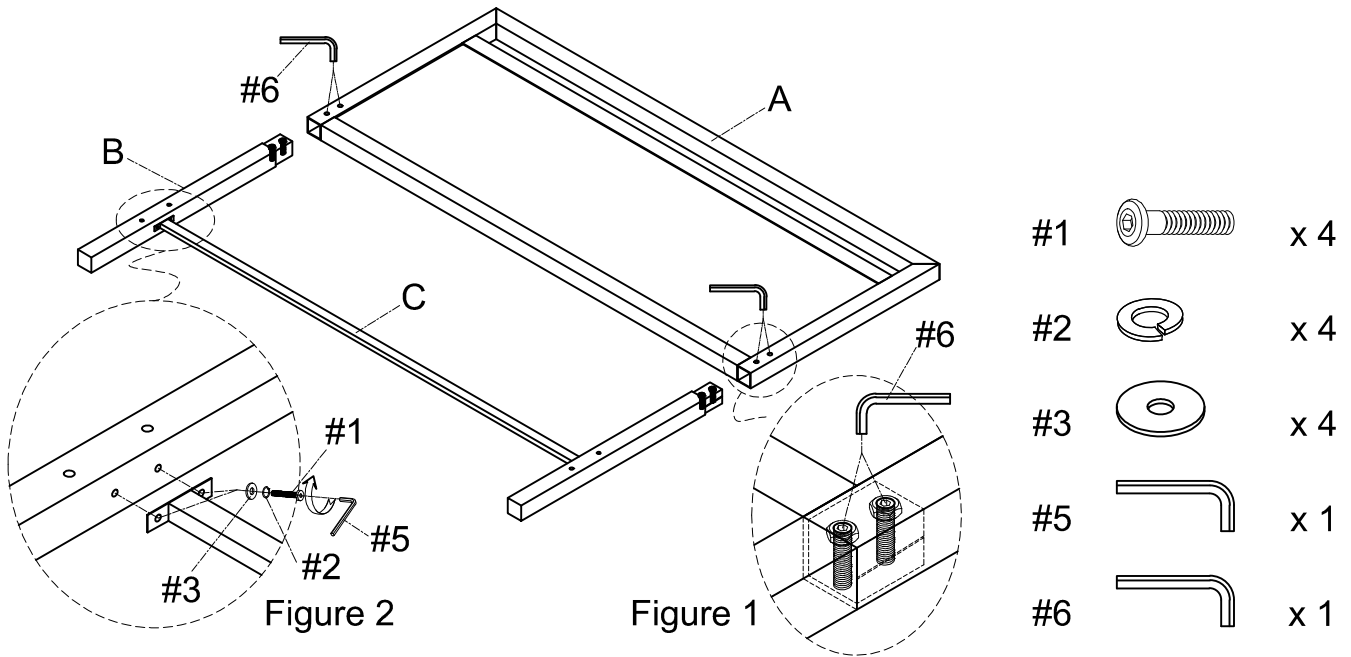

Step 2. Attach side rails (part E) to footboard panel (part D) using bolts (part #1), spring washers (part #2), flat washers (part #3) and allen wrench (part #5).

NOTE: Please do not fully tighten bolts until unit is fully assembled.

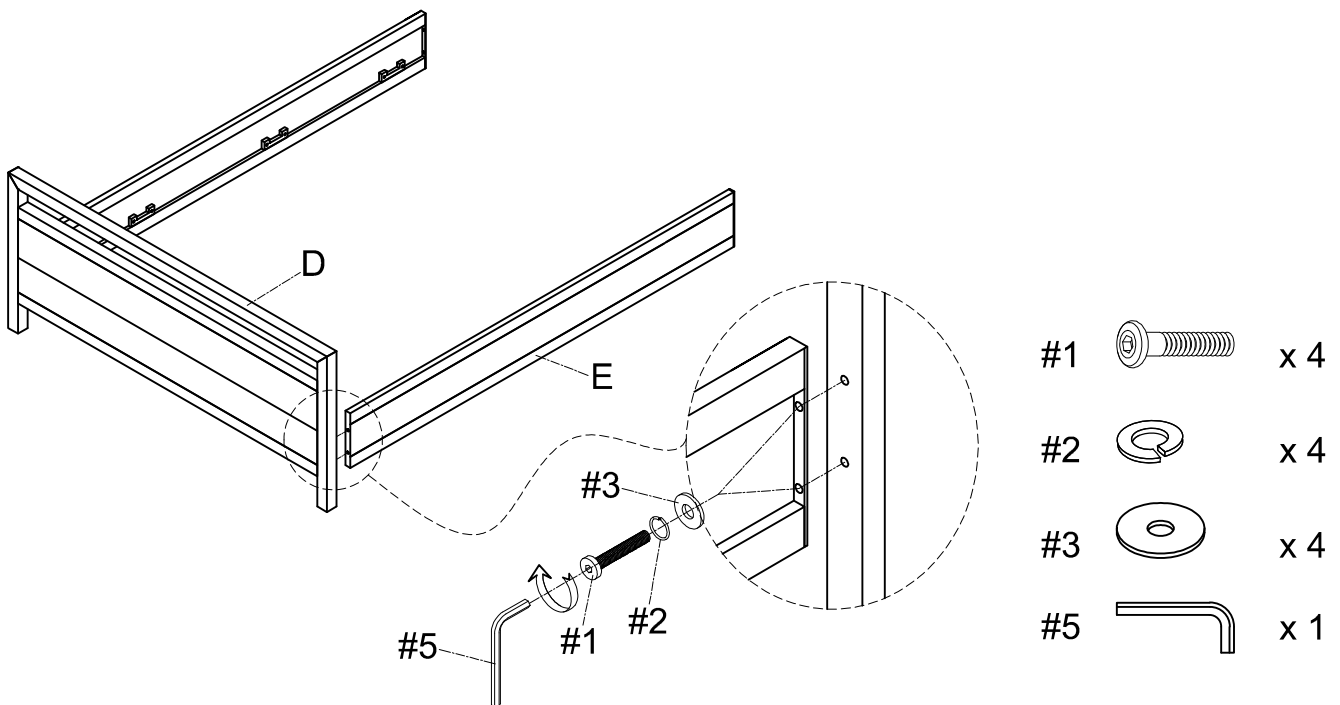

Step 3: Carefully turn assembled unit (parts A, B & C) upright. Attach side rails (part E) to headboard posts (part B) using bolts (part #1), spring washers (part #2), flat washers (part #3) and allen wrench (part #5).

NOTE: Please do not fully tighten bolts until unit is fully assembled.

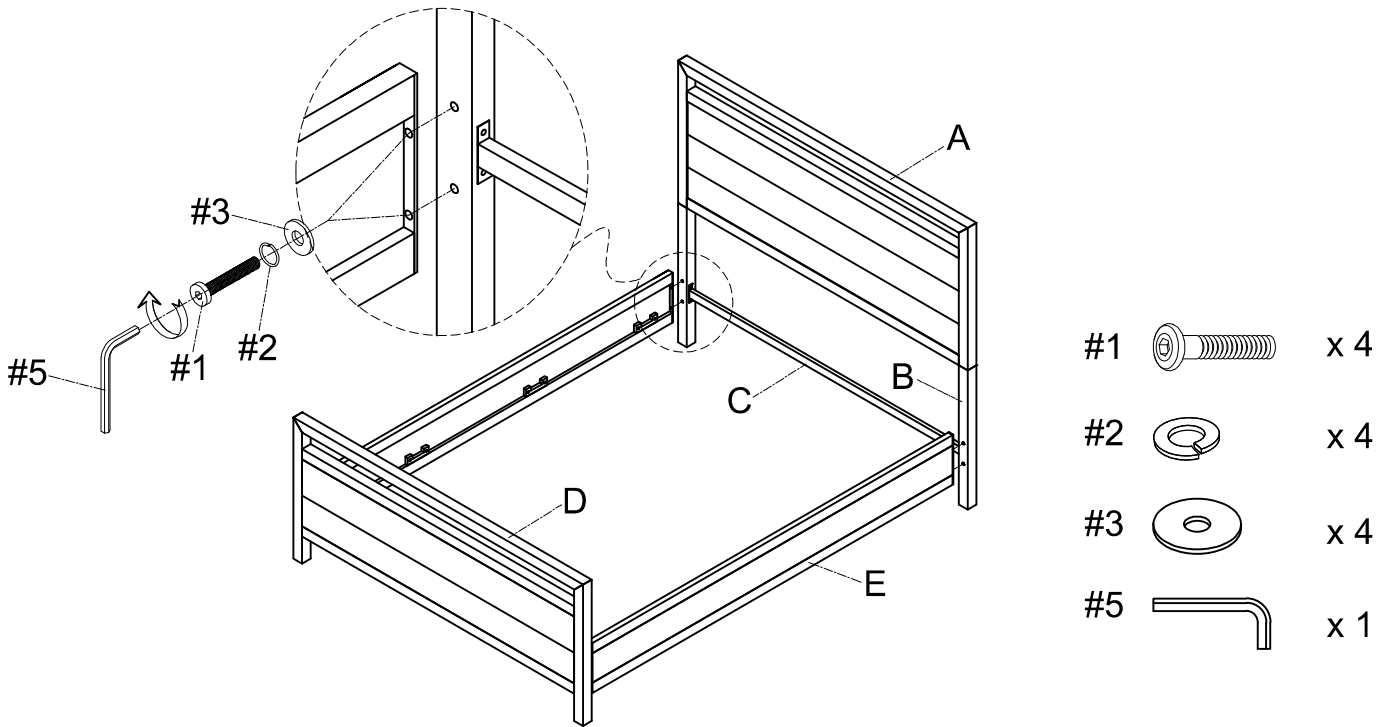

Step 4. Attach support legs (part G) to slats (part F). See Figure 1. Attach assembled unit (parts F & G) to side rails (part E) using screws (part #4) and phillips head screwdriver. See Figure 2.

NOTE: Please fully tighten all bolts at this time.

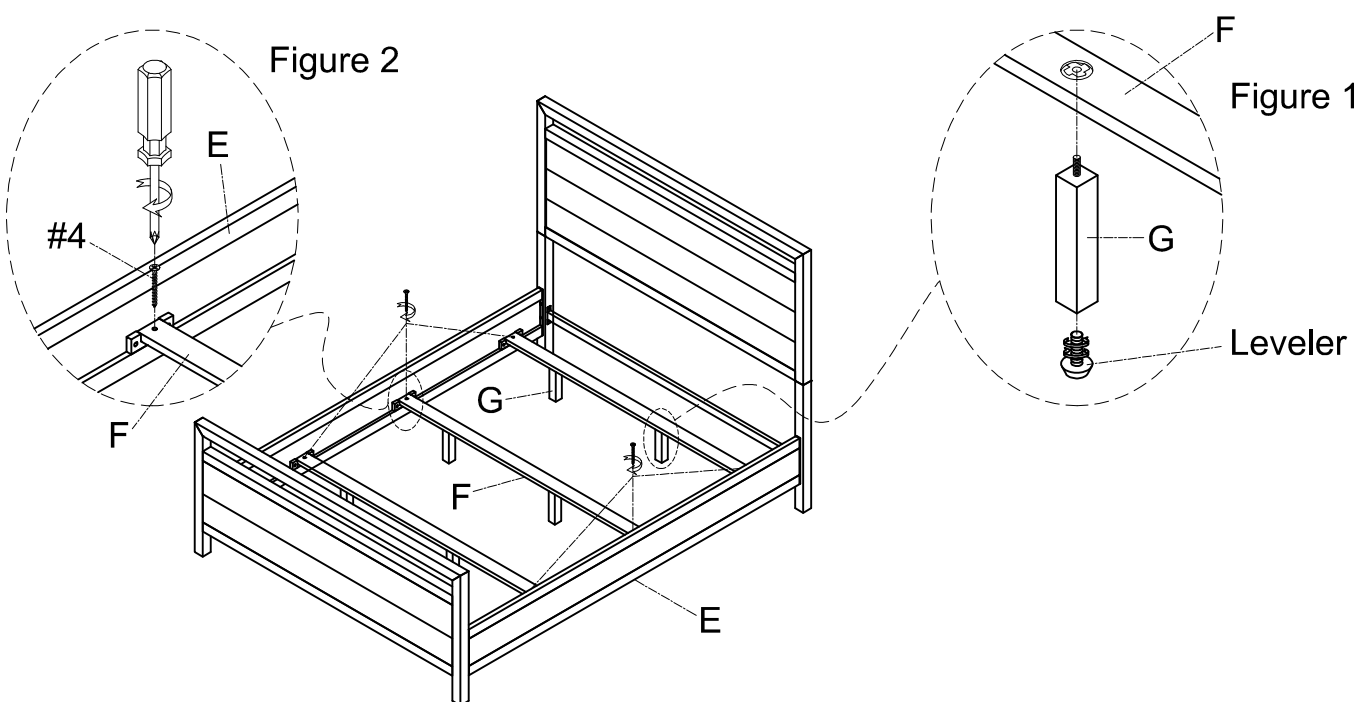

#4  x 6

