

ASSEMBLY INSTRUCTIONS

Swivel Recliner & Footstool





This product is designed to seat people up to a maximum of 115kgs (18 stone)

Check and re-tighten parts/nuts & bolts every three months

For any missing/damaged parts, please contact your retailer



Please retain these instructions for future reference and in case of any queries, please quote the following batch number to your retailer.

(The batch number is also located on the underside of the seat pad or footstool pad)

IMPORTANT: Please read this manual carefully before beginning assembly of this product. Keep this manual for future reference.

S A F E T Y I N F O R M A T I O N

Identify all the parts and hardware.

Do not discard of the packaging until you have checked that you have all of the parts and hardware required.

Hardware package may have spare parts.

WARNING:

This item contains small parts which can be swallowed by children and pets. Keep children and pets away during assembly.

To avoid danger of suffocation, always keep plastic bags away from children and pets.

We recommend that you assemble this unit on a carpeted floor to avoid scratches.

We do not recommend the use of power tools for assembly as this could damage the unit. Only use manual tools.

Requires 2 people for ease of assembly.

C A R E A N D M A I N T E N A N C E

Wipe regularly with clean water and a damp, clean, soft white cloth

General cleaning can be done as needed with a mild detergent and water solution. Always rinse with clean water and dry

For heavy soiling, dampen a soft white cloth or soft bristle brush. Use care as scrubbing can damage the surface

More difficult stains can be treated, but this should be occasional, not daily, cleaning

ANY cleaning solution used must be removed with clean water and a clean white cloth

Cleaning residue left on the material can cause it to dry out and crack, or affect the colour

DO NOT use any cleaners with corrosive ingredients (lye, acids or ammonia).

PRE - ASSEMBLY INFORMATION

PARTS DESCRIPTION

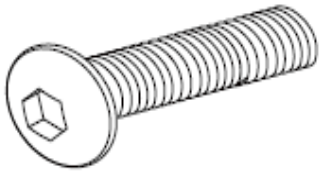

M8*45
Qty2



M6*20
Qty6

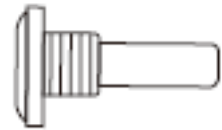

Bolt & clip
Qty2

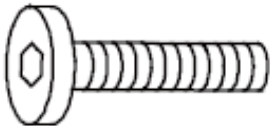

M6*25
Qty4





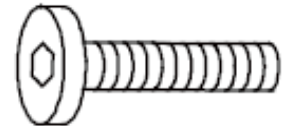

Discs
Qty8



M8*38
Qty18

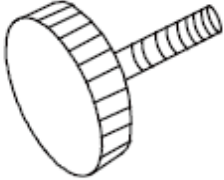

PRE - ASSEMBLY INFORMATION

PARTS DESCRIPTION

 <p>Washer Qty18</p>	 <p>Plate Qty4</p>	 <p>Nuts Qty1</p>
 <p>Recliner handle Qty1</p>	 <p>Spanner Qty1</p>	 <p>5mm Allen key Qty1</p>

PRE - ASSEMBLY INFORMATION

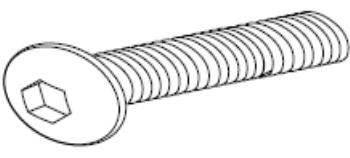
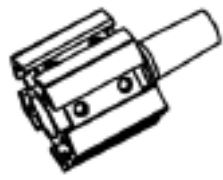
PARTS DESCRIPTION

 <p>M8*60 Qty1</p>	 <p>Spindle Qty1</p>	 <p>Qty1</p>
---	---	---

ASSEMBLY

STEP 1

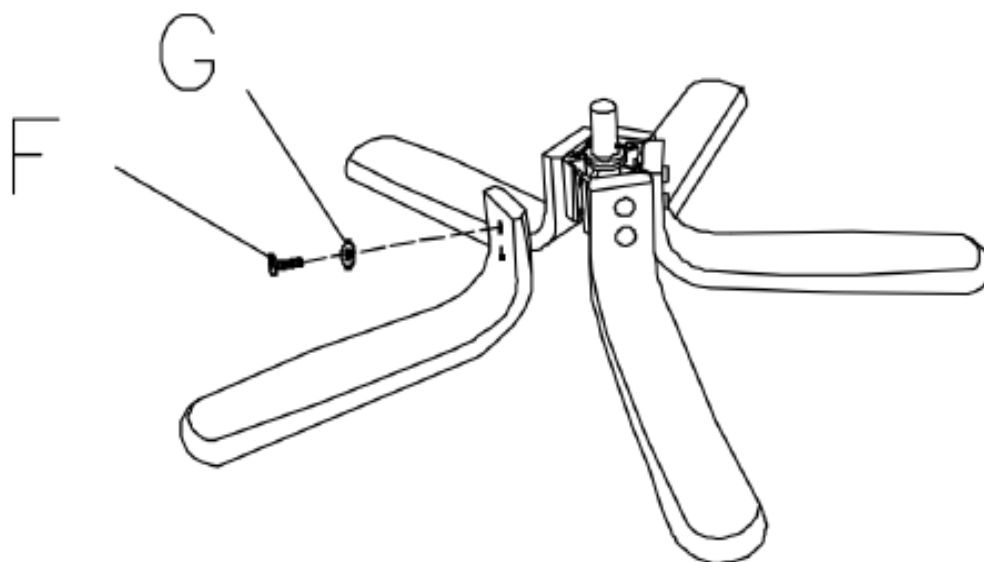

STEP 2

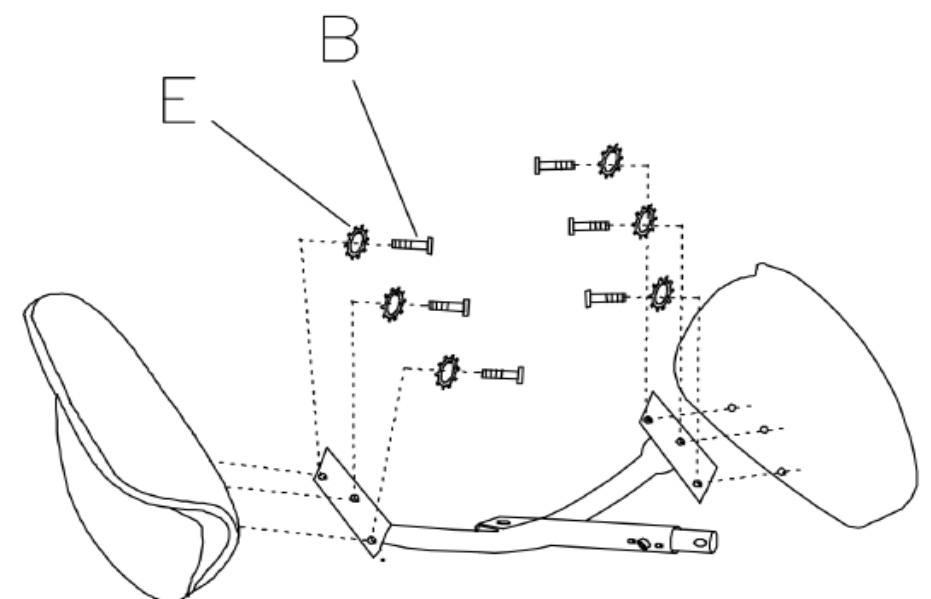

ASSEMBLY

STEP 3

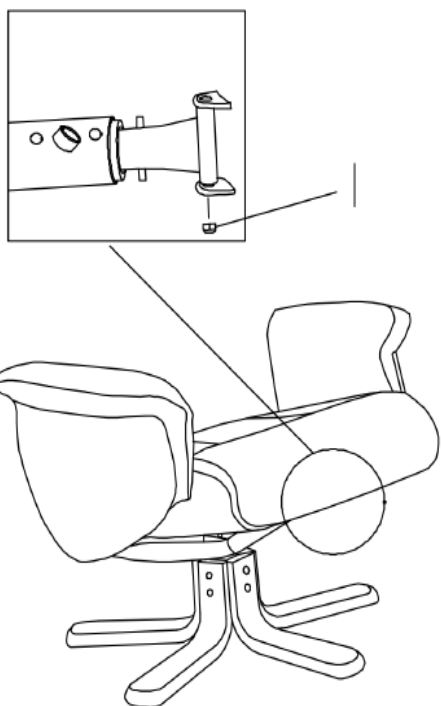

STEP 4

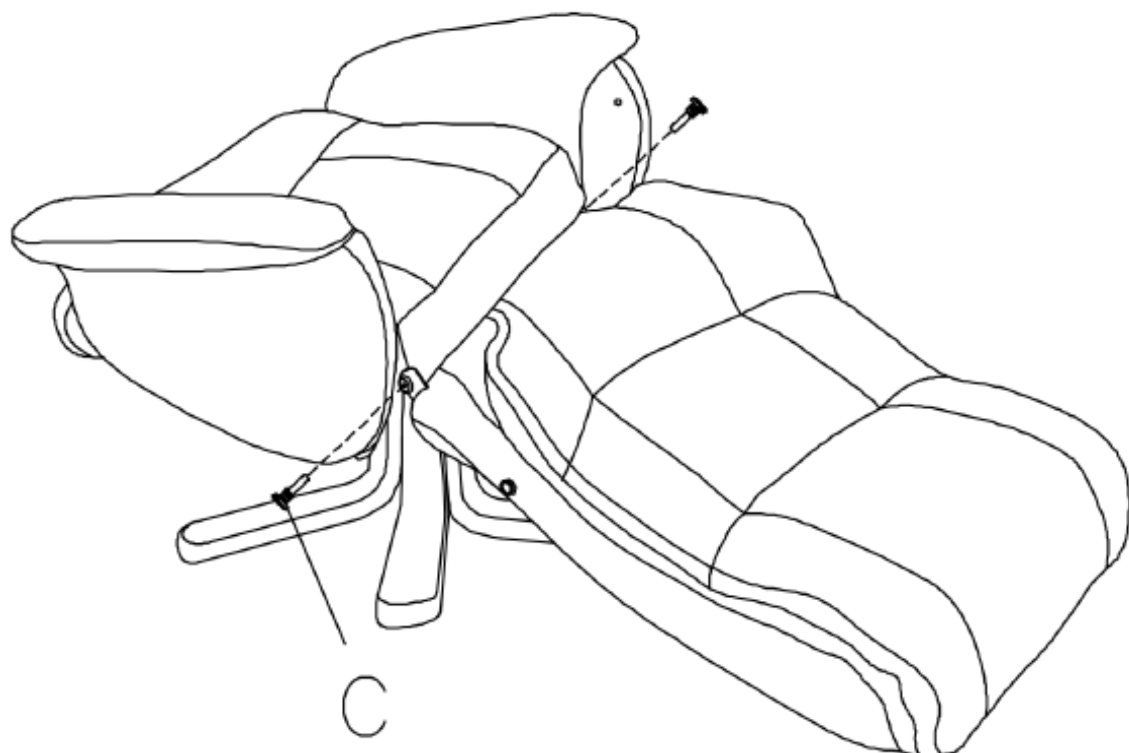

ASSEMBLY

STEP 5

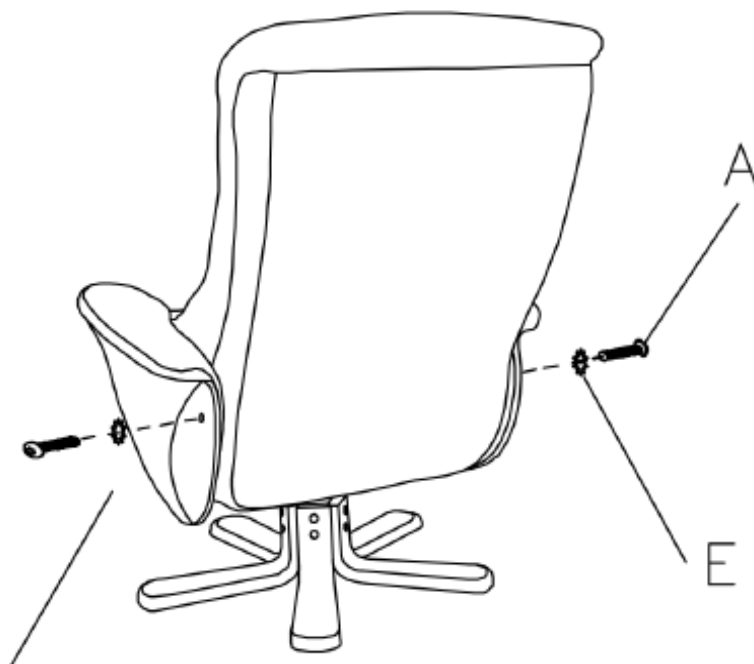

Align the backrest and drillings prior to unzipping the back of the armrest

STEP 6

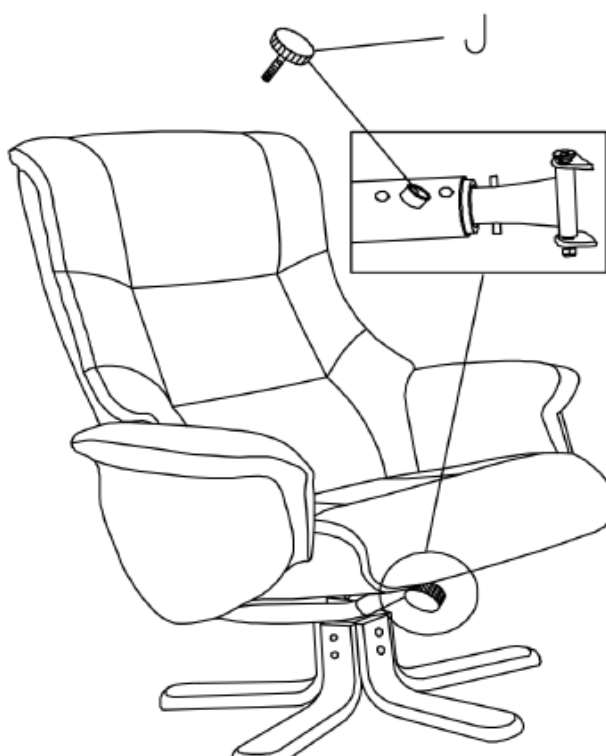

ASSEMBLY

STEP 7

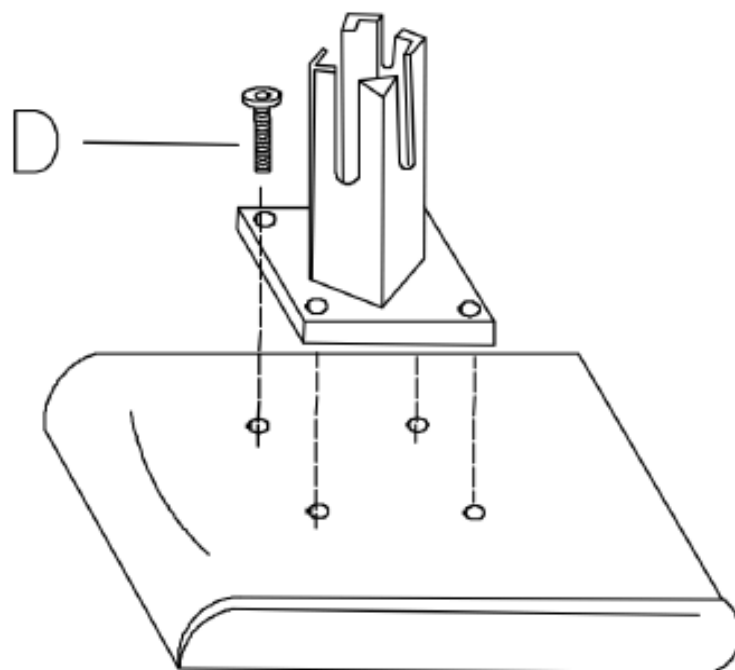

STEP 8

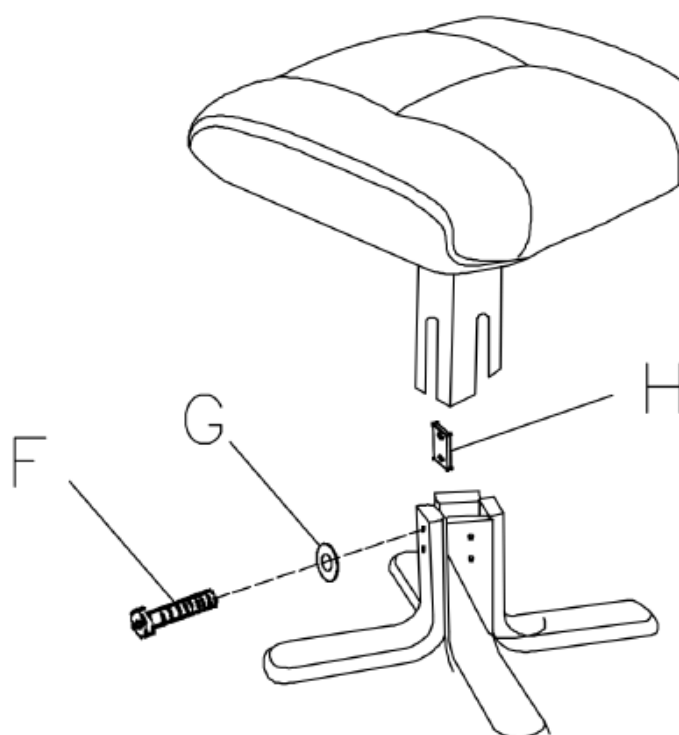

ASSEMBLY

STEP 9

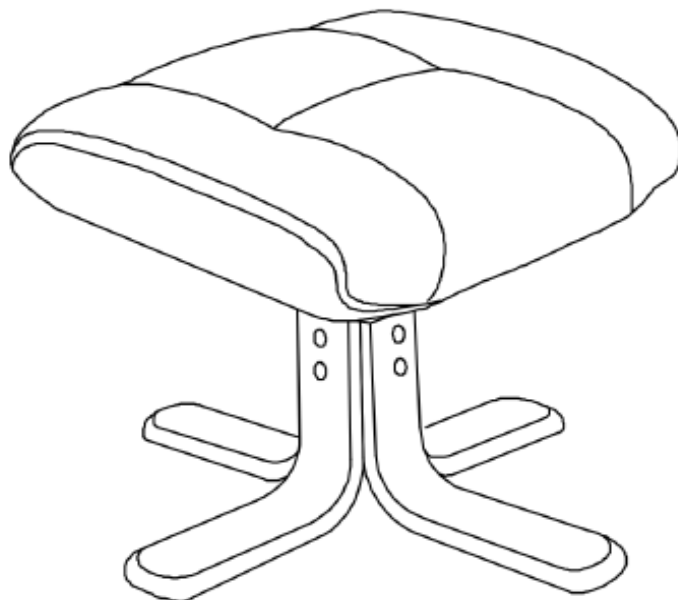

WARRANTY

Thank you for purchasing a product demanding, high-quality standards and are guaranteed for domestic use against manufacturing faults for a period of 12 months from the date of purchase.

These products have been made to

This warranty does not affect your statutory rights.

We reserve the right to repair or replace the defective product, at its discretion.

This product is guaranteed for 12 months if used for normal purposes. Any warranty is invalid if the product has been overloaded or subject to neglect, improper use or an attempted repair by other than an authorized agent. Heavy-duty or daily professional/commercial usage are not guaranteed.

Due to continuous product improvement, we reserve the right to change the product specifications without prior notice.