

Assembly Manual

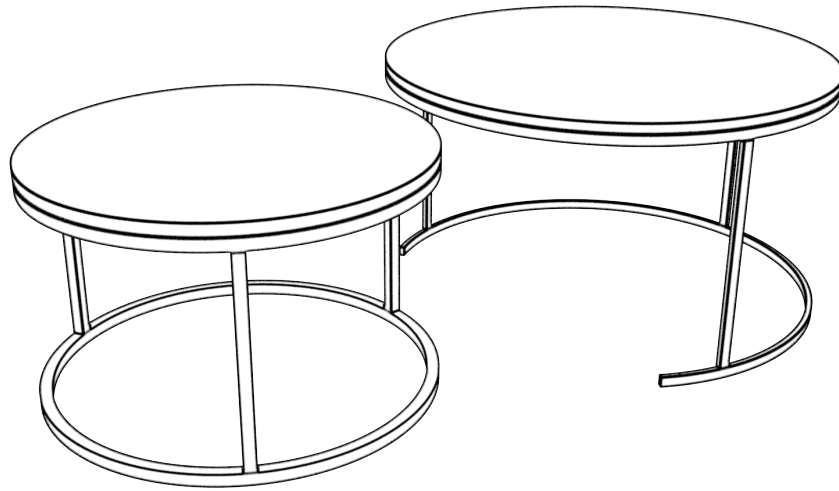

1

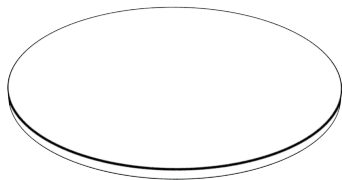

1pc

2

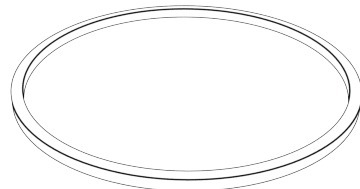

1pc

3



3pc

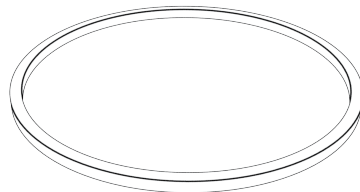

4



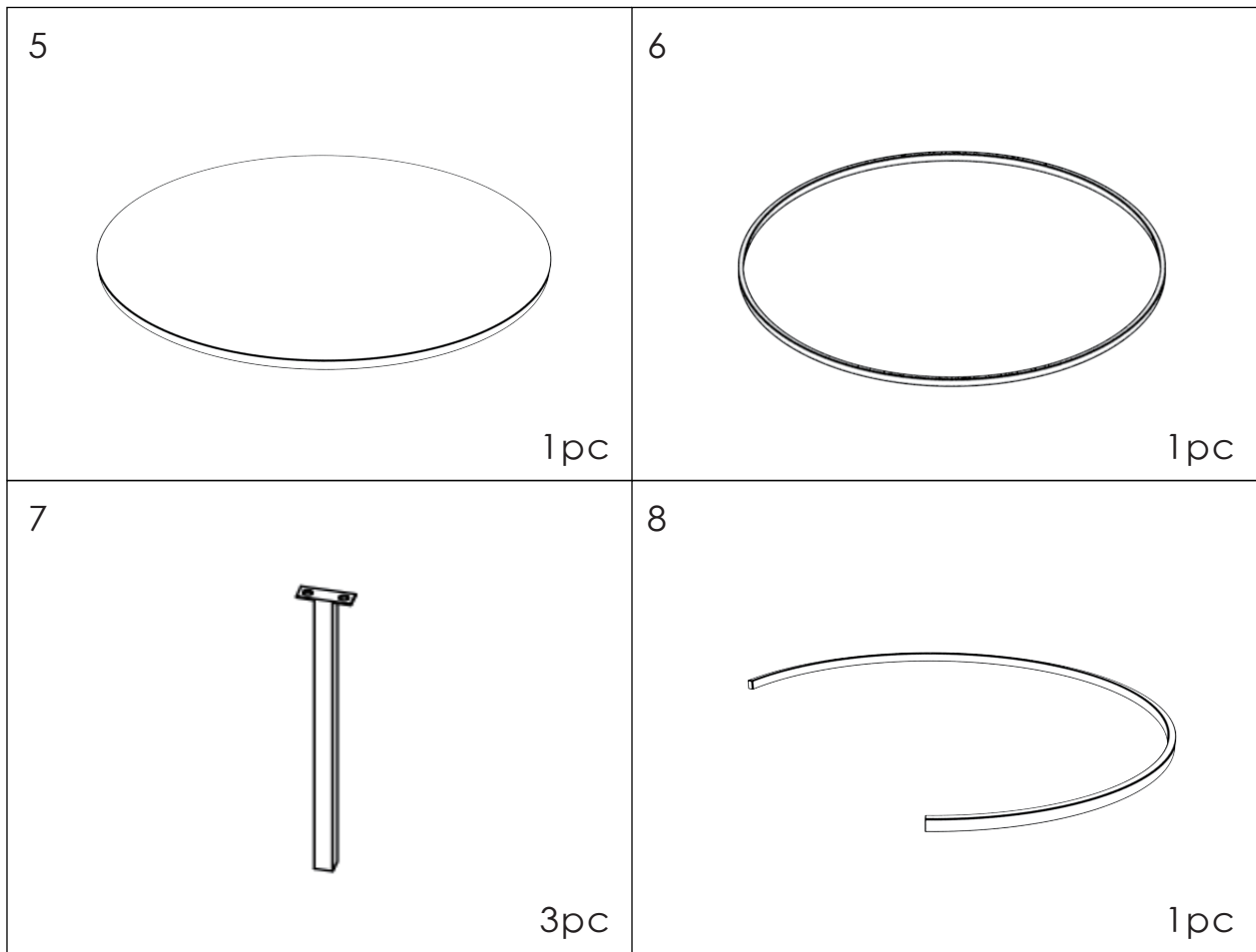

1pc

Assembly Manual



Hardware Accessories								
NO.	PICTURE	SIZE	QTY		NO.	PICTURE	SIZE	QTY
A		M6*L10mm	12		B		M6*L35mm	6
C			1					

SPARE								
NO.	PICTURE	SIZE	QTY		NO.	PICTURE	SIZE	QTY
A		M6*L10mm	1		B		M6*L35mm	1

Before assembly, please put all parts on a neat and clean sheet

Exploded View

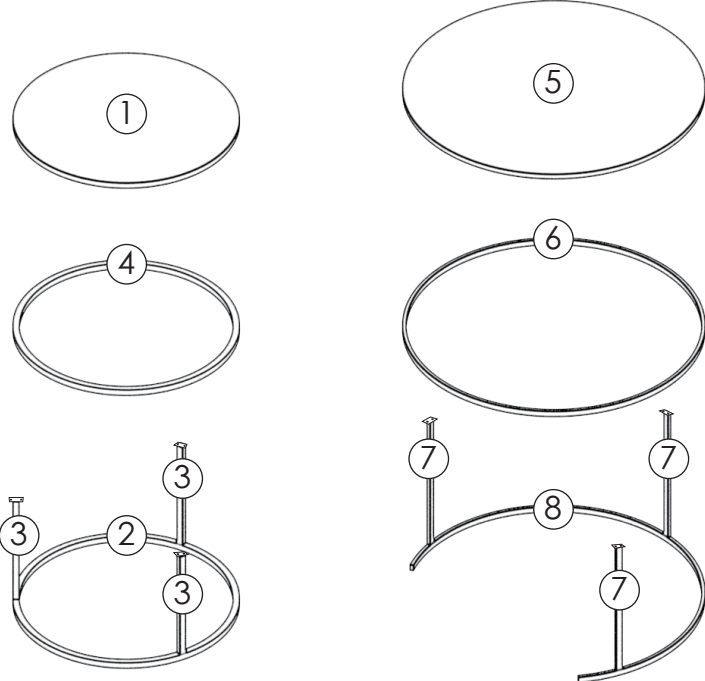

Installation procedures

step 1

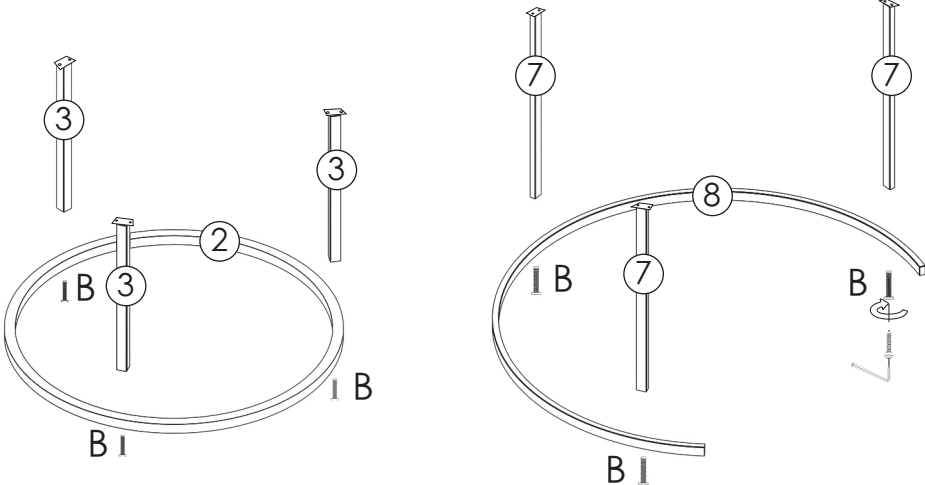

B * 6 (3) * 3 (7) * 3 (2) * 1 (8) * 1

step 2

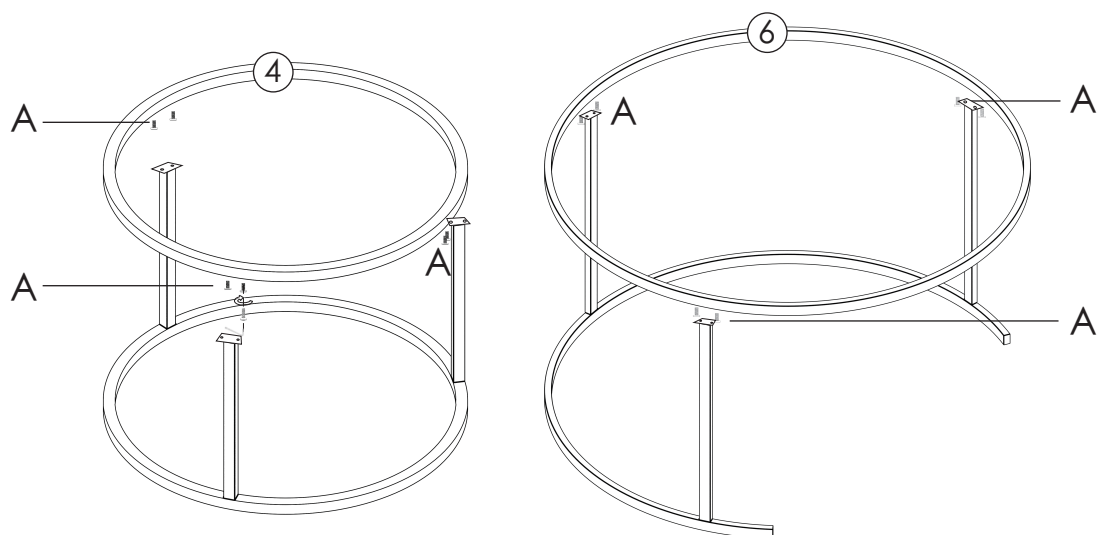

A*12  ④*1 ⑥*1

step 3

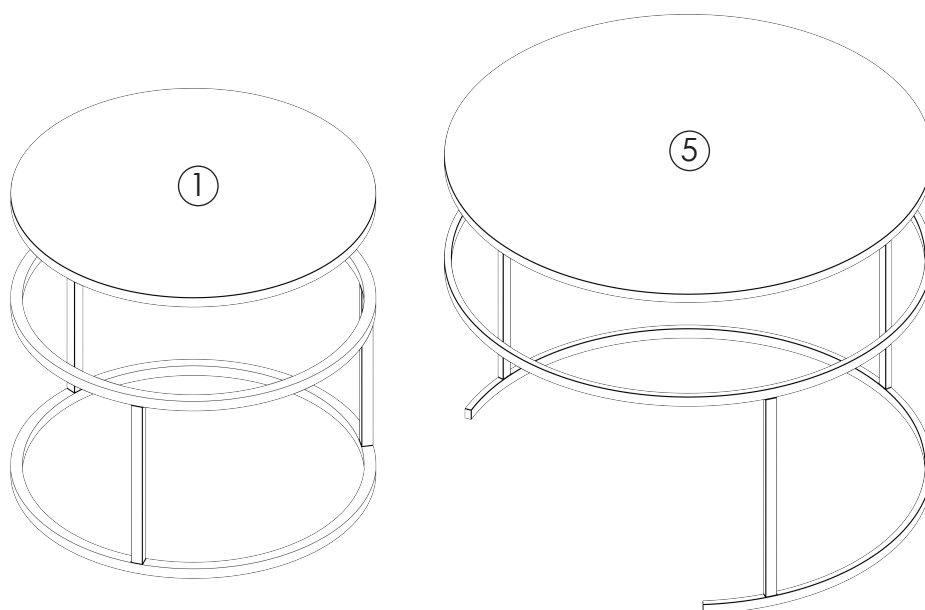

①*1 ⑤*1

When assembling stand with board ring, and if you find it is not in right position then need to adjust the screw, change the position a little bit and then it will be adjusted.

COMPLETED DRAWING

