

Installation & Assembly

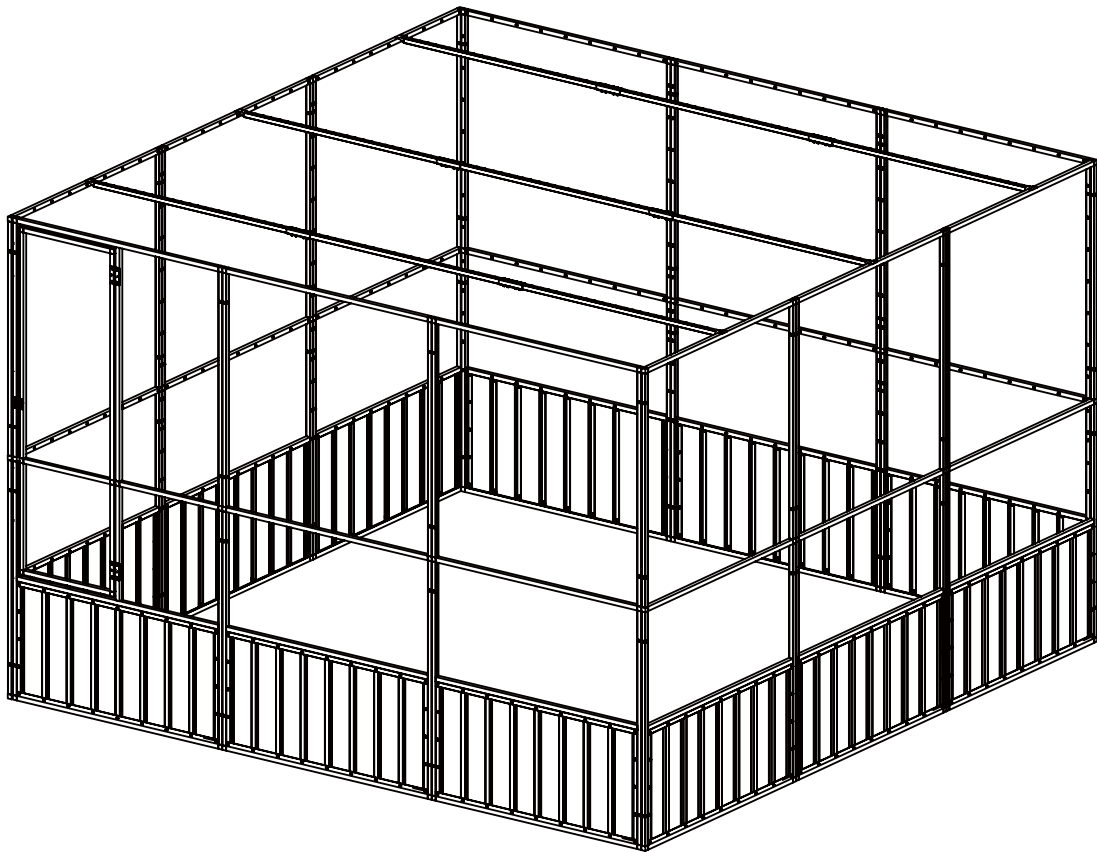

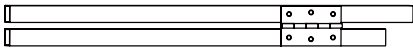

① x1

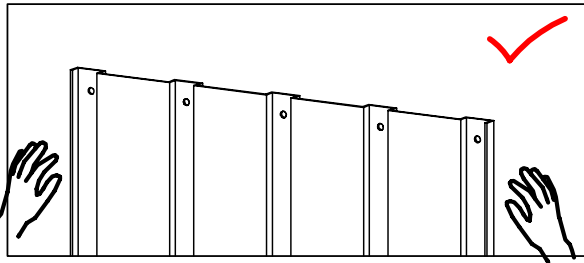
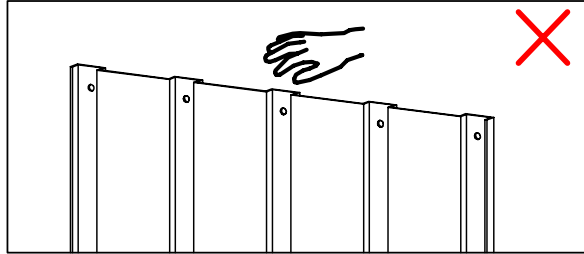
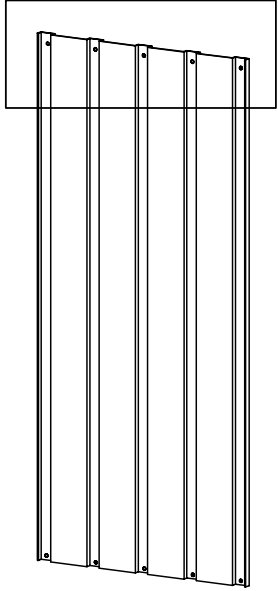
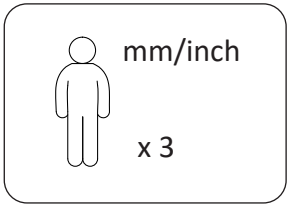
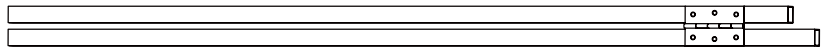

② x1

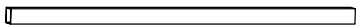

③ x3

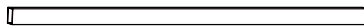

④ x1



⑤ x1



⑥ x1

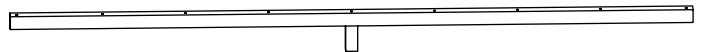

⑦ x2



8 x1

9 x24

10 x45

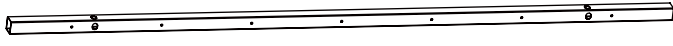

11 x23



13 x6



14 x24



15 x24

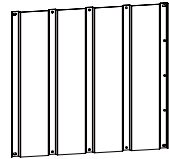

16 x24

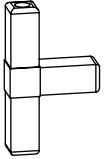

17 x26

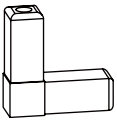

18 x52

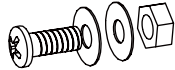

M4x8/0.3

19 x288

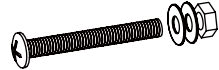

M6x 50/2.0

20 x48



21 x1



22 x108

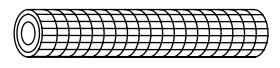

33000/1299.2

23 x1



24 x1071

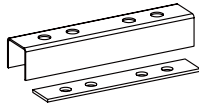

25 x6



M6x 30/1.2

26 x24



27 x93



28 x3

1

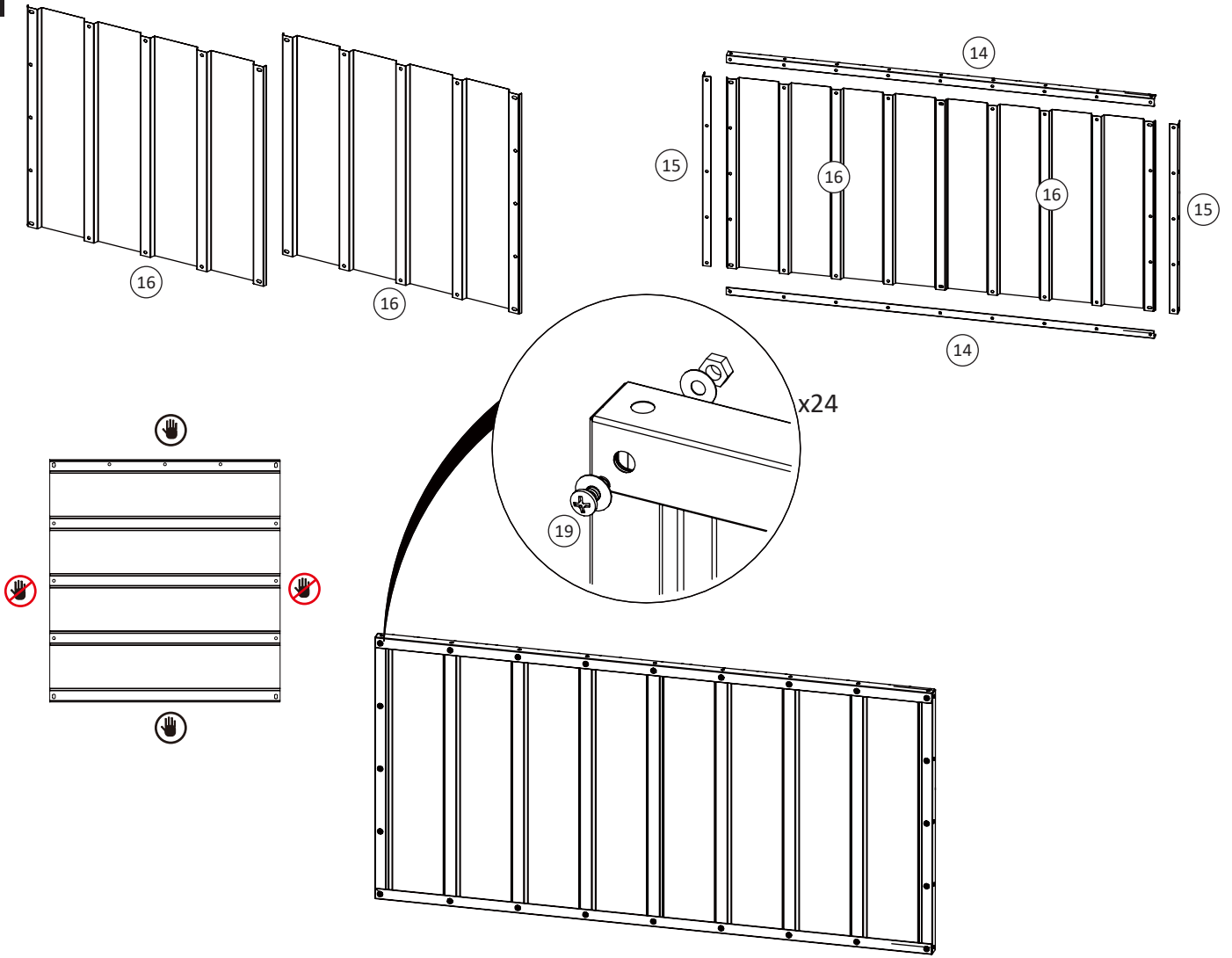

2

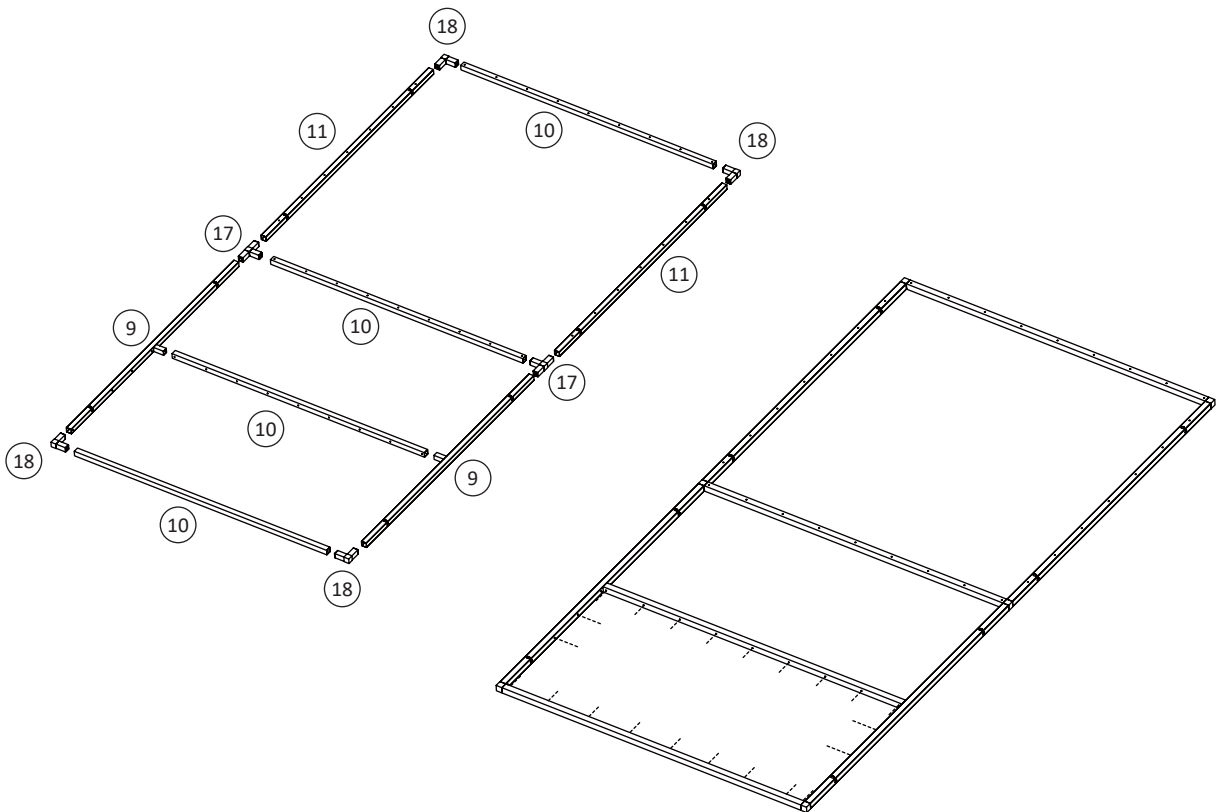

3

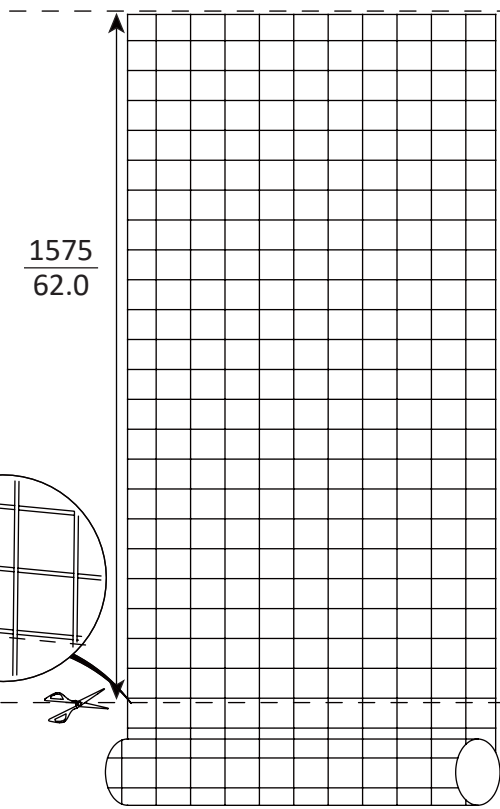
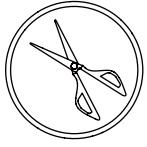

1575
62.0

(23)

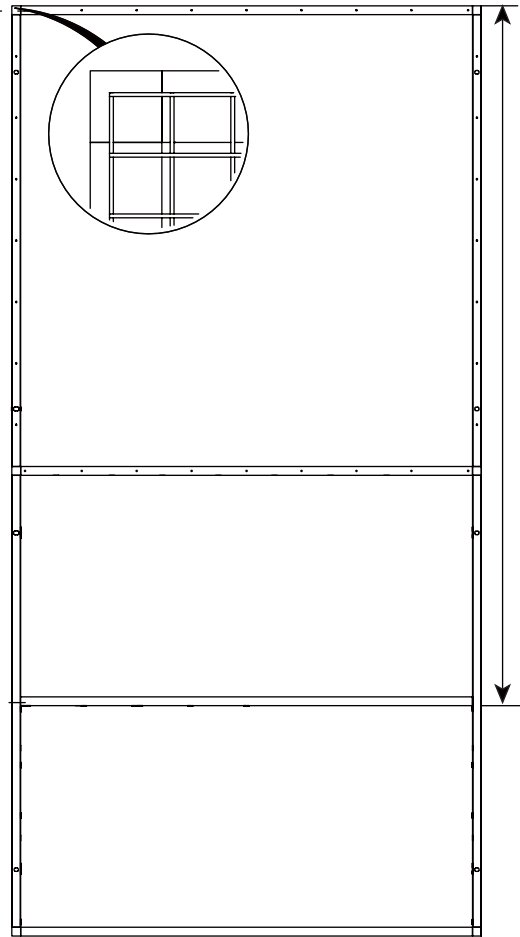

1590
62.6

4

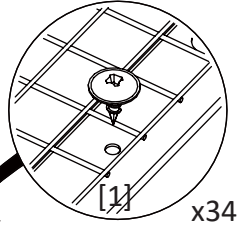
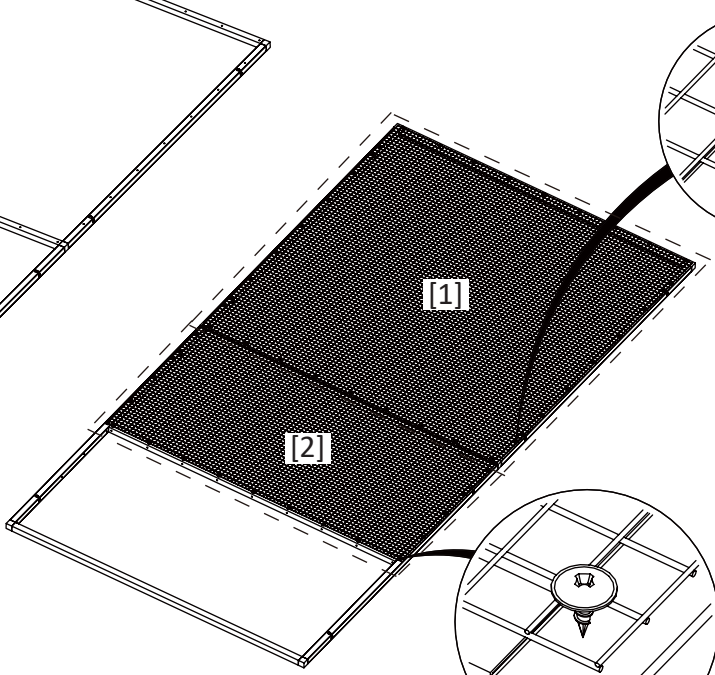
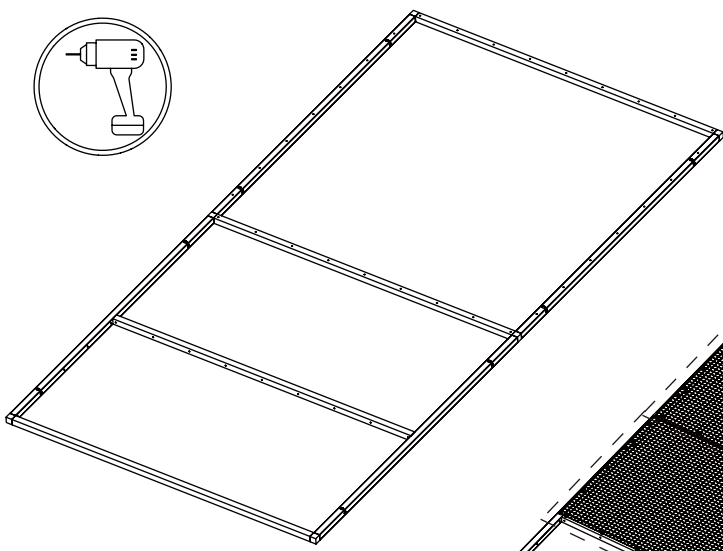
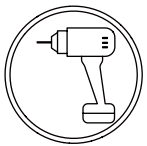

x34

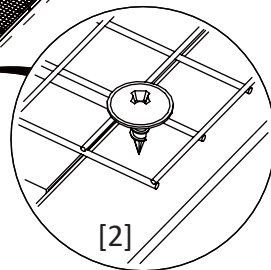

x18

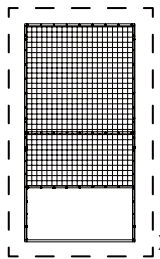

x11

5

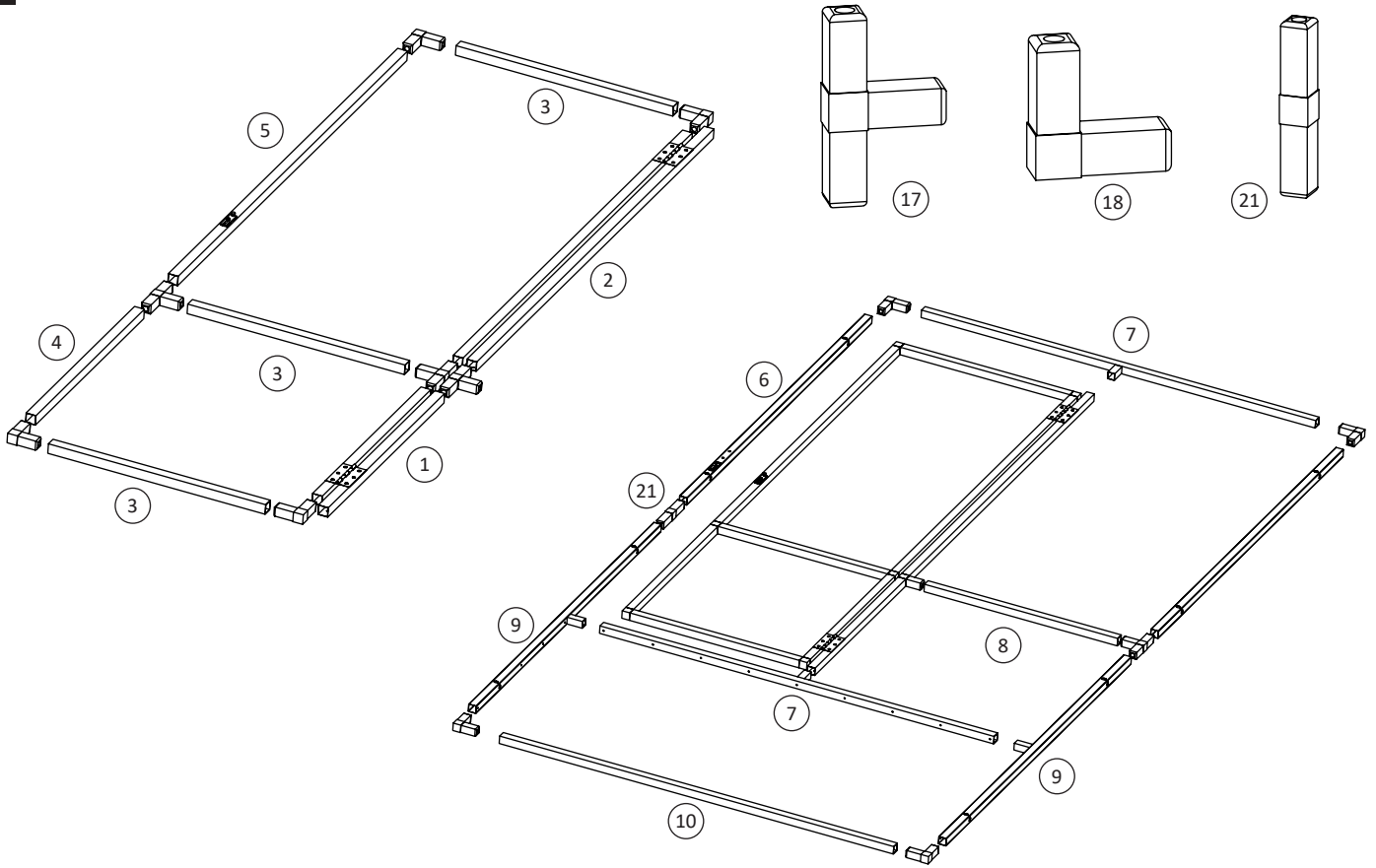

6

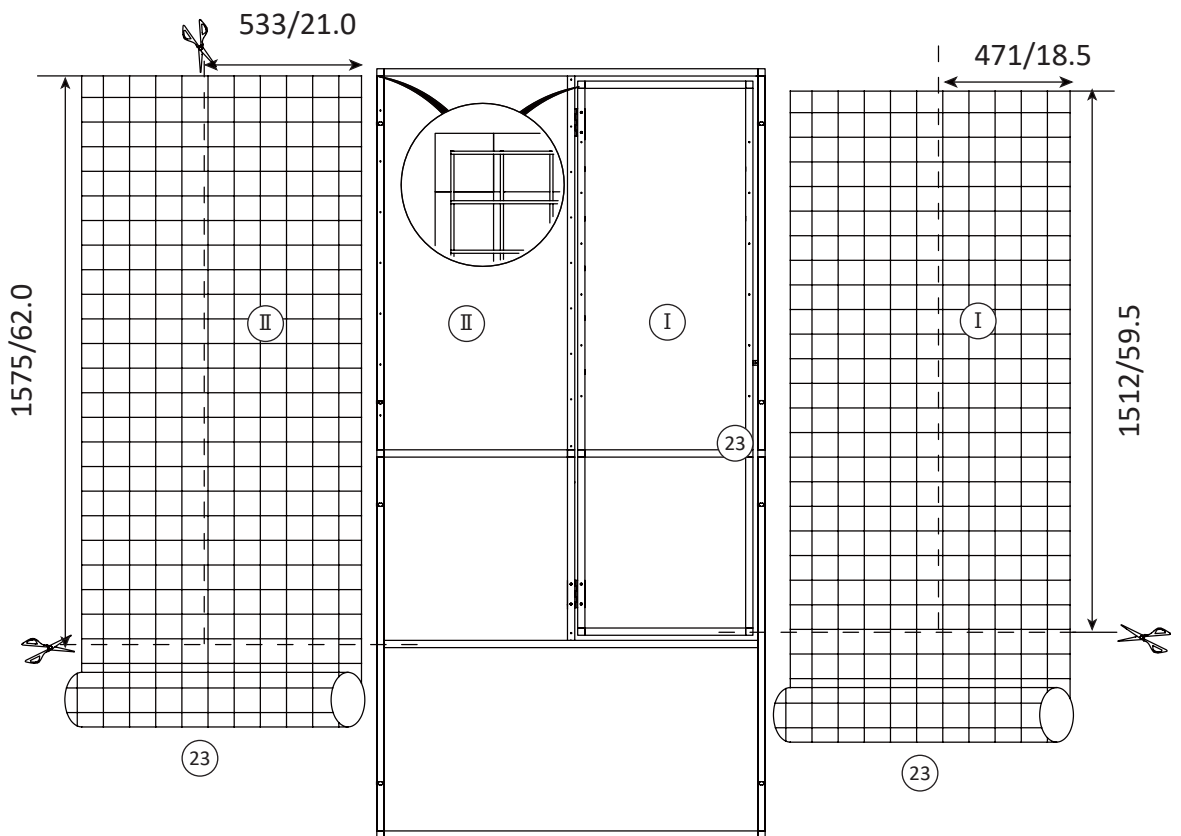
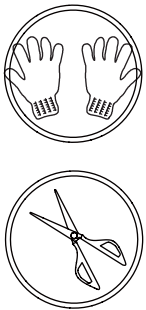

7

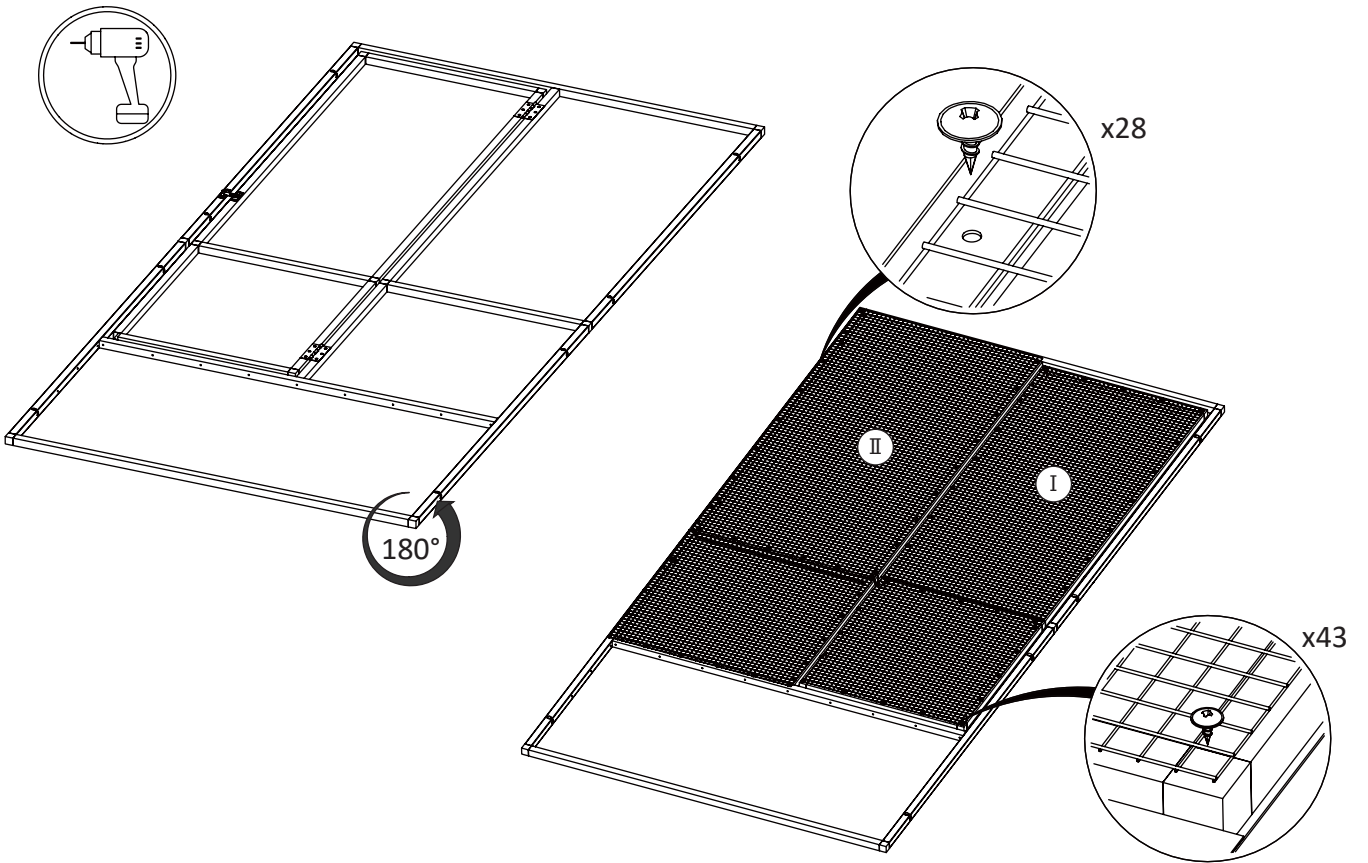

8

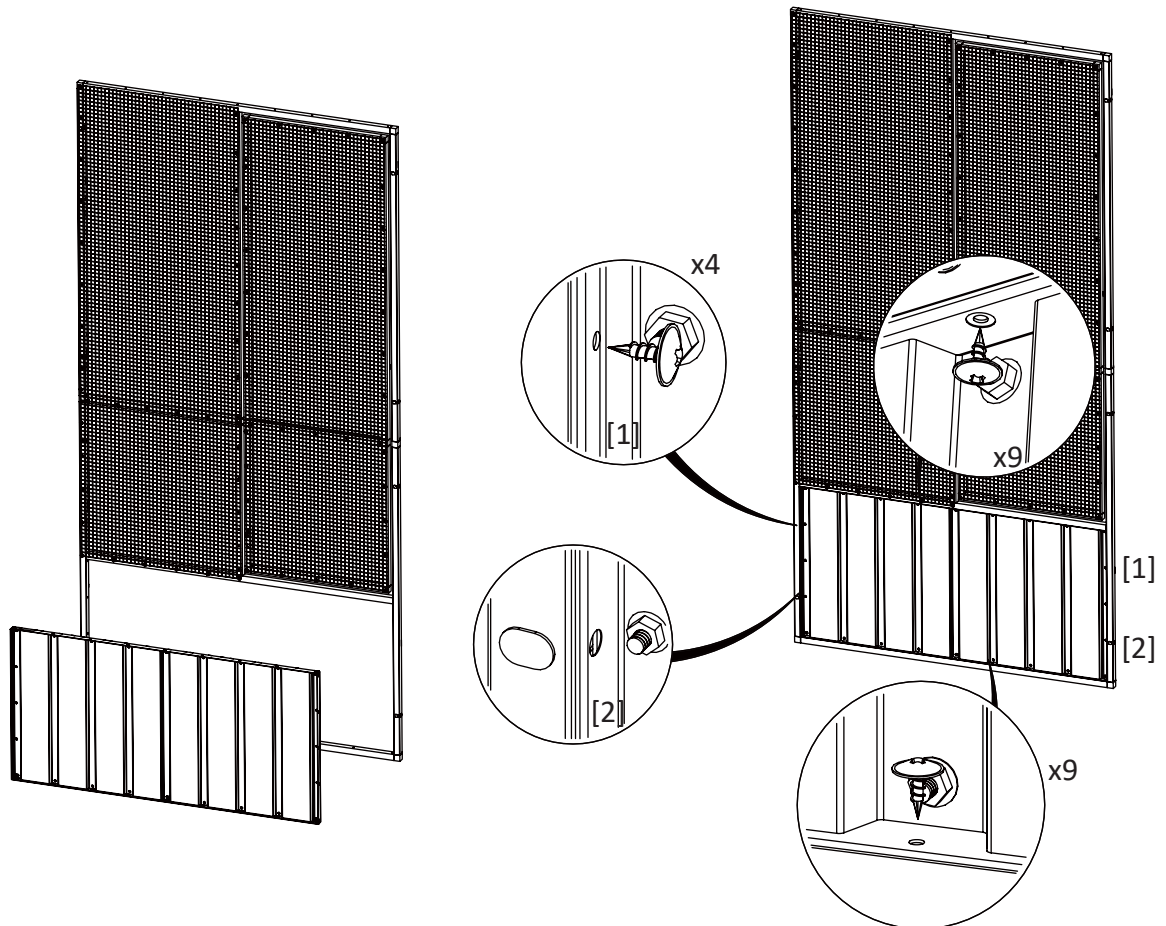

9

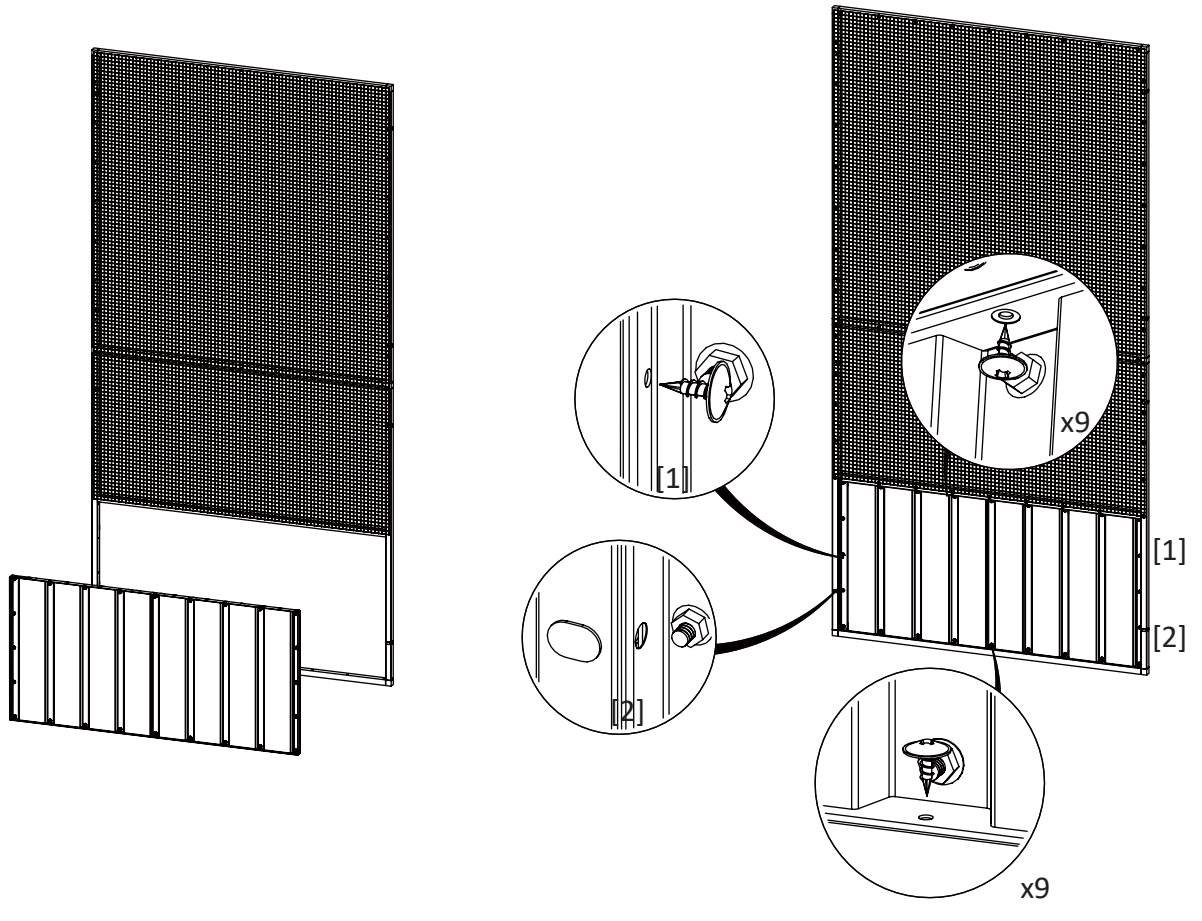
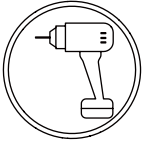

10

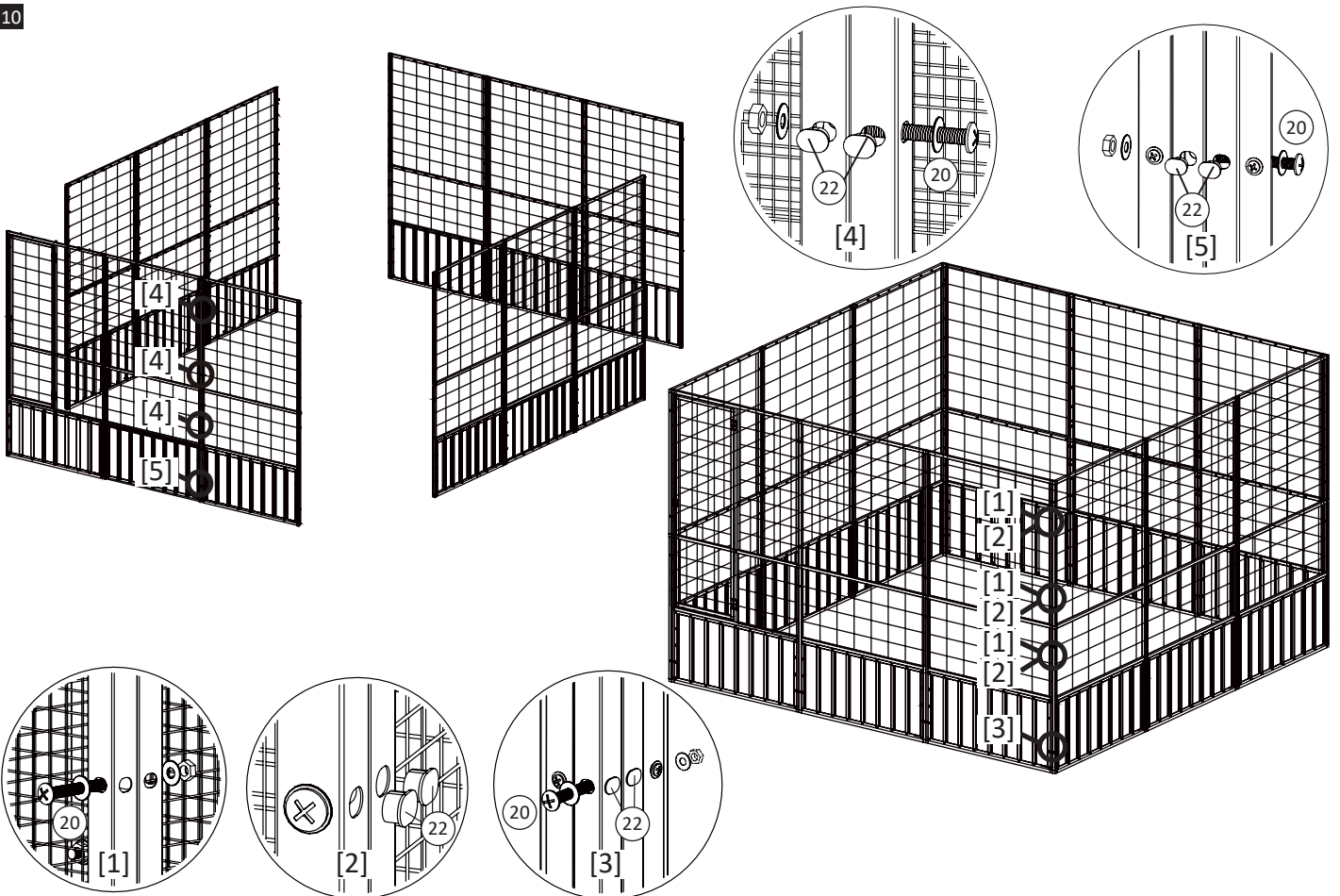

11

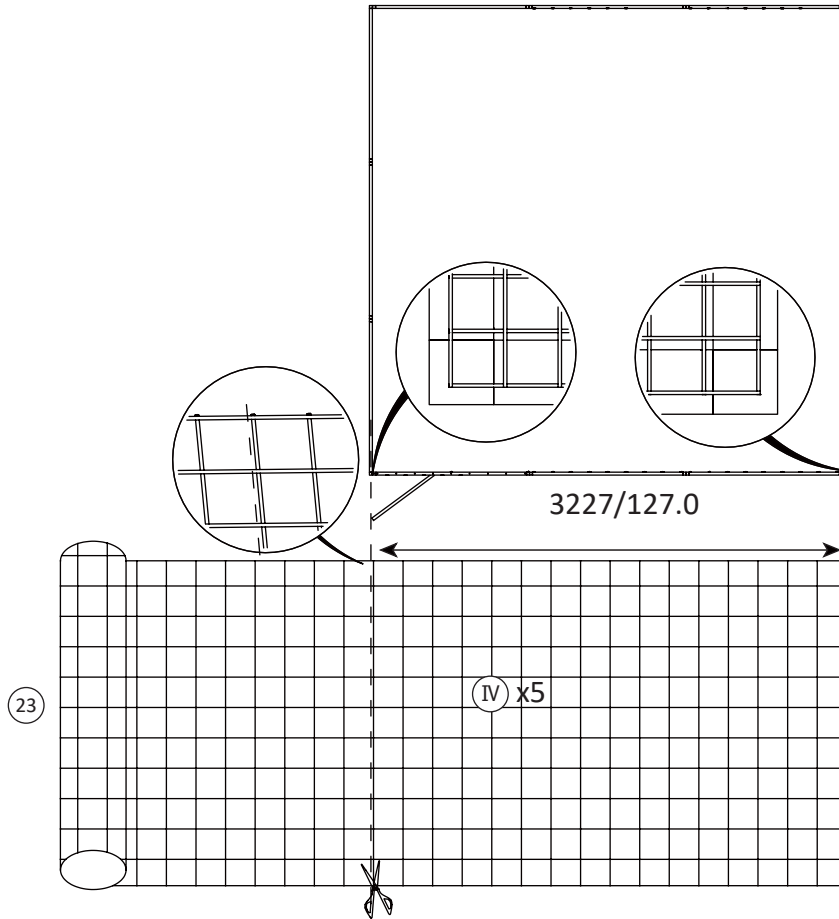
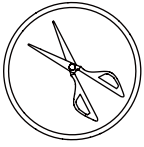

12

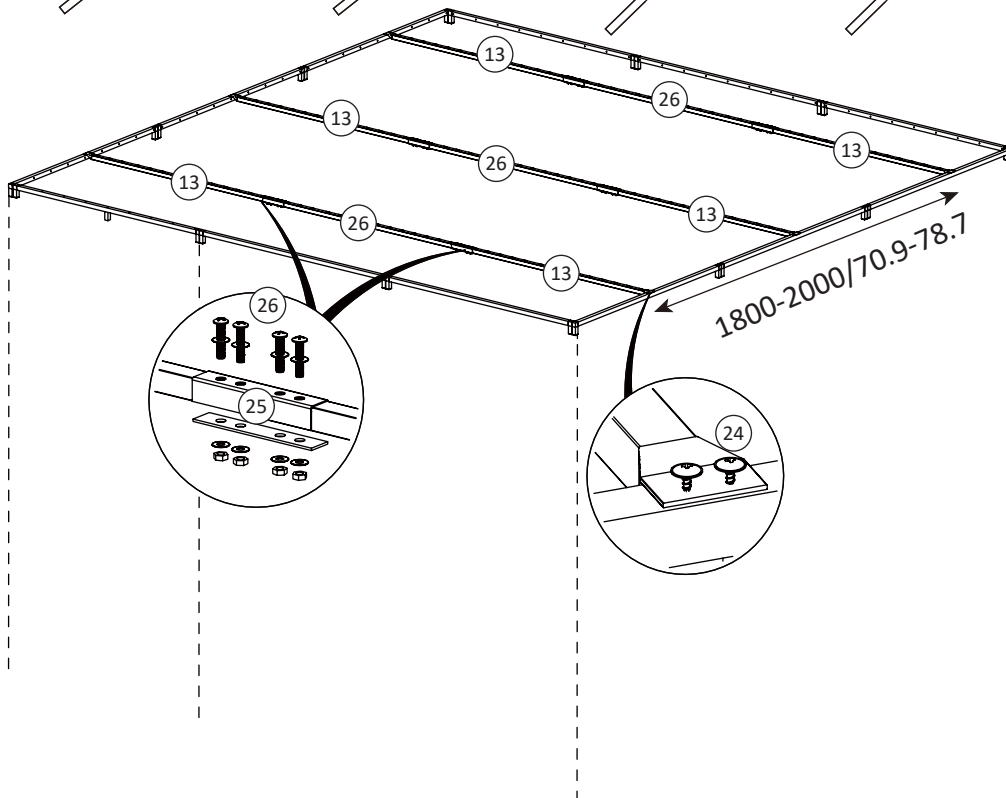
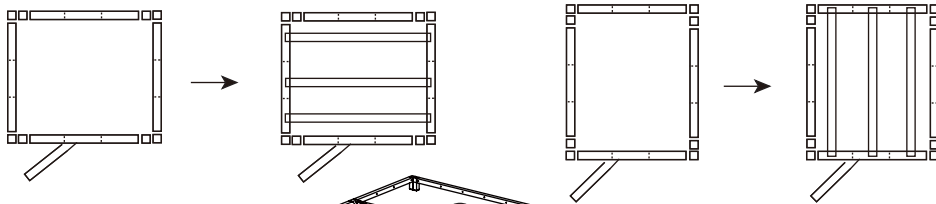

13

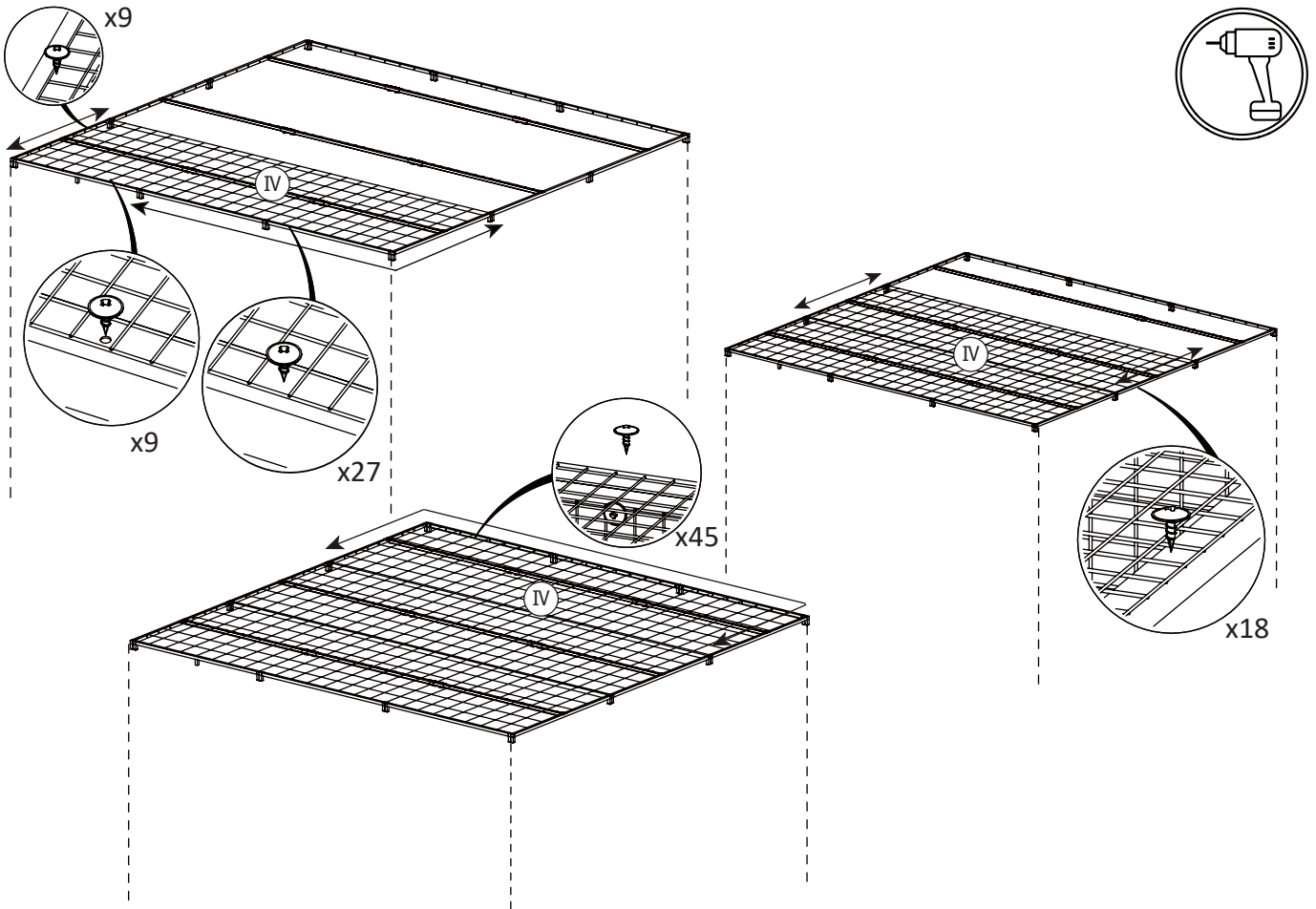

14

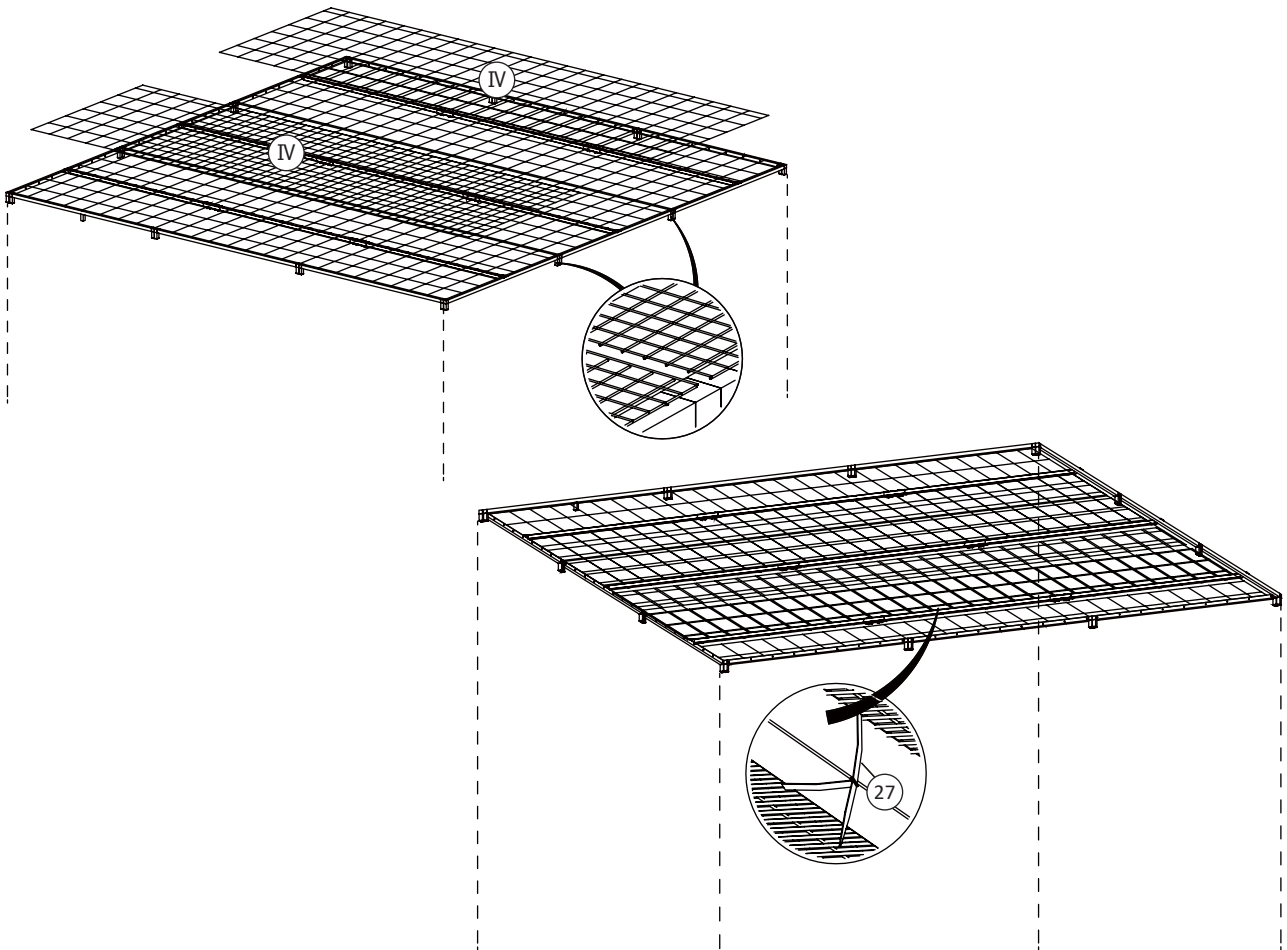

1 Warnings and personal safety • Please wear safety glasses, gloves, safety shoes, and head protection when you install the planter. • Step 4/7/13 : NOTE - Please determine the position of the screw by yourself in the case that there is no pilot hole. • Warning! Must wear protective gloves.

DE

1 Warnungen und persönliche Sicherheit • Bitte tragen Sie Schutzbrille, Handschuhe, Sicherheitsschuhe und Kopfschutz beim Zusammenbau des Pflanzgefäßes. • Schritt 4/7/13: HINWEIS - Bitte bestimmen Sie die Position der Schraube selbst, falls keine Vorbohrung vorhanden ist. • Warnung! Schutzhandschuhe tragen.

FR

1 Avertissements et sécurité personnelle • Veuillez porter des lunettes de sécurité, des gants, des chaussures de sécurité et un casque de protection lorsque vous installez la jardinière. • Étape 4/7/13: NOTE - Veuillez déterminer vous-même la position de la vis dans le cas où il n'y a pas de trou pilote. • Avertissement ! Portez des gants de protection.

NL

1 Waarschuwingen en persoonlijke veiligheid • Draag een veiligheidsbril, handschoenen, veiligheidschoenen en hoofdbescherming wanneer u de plantenbak installeert. • Stap 4/7/13: OPMERKING - Bepaal zelf de positie van de schroef indien er geen geleidingsgat is. • Waarschuwing! Draag beschermende handschoenen.

IT

1 Avvertenze e sicurezza personale • Quando si installa la fioriera si prega di indossare occhiali di sicurezza, guanti, scarpe di sicurezza e protezioni per la testa. • Passo 4/7/13: NOTA - nel caso in cui non ci sia un foro pilota, determinare da soli la posizione della vite. • Avvertenza! Indossare guanti protettivi.

PL

1 Ostrzeżenia i bezpieczeństwo osobiste • Podczas montażu donicy należy mieć założone okulary ochronne, rękawice, obuwie ochronne oraz ochronę głowy. • Krok 4/7/13: UWAGA - Prosimy o samodzielne ustalenie pozycji śruby w przypadku, gdy nie ma otworu pilotażowego. • Ostrzeżenia! Włóż rękawice ochronne.

SE

1 Varningar och personlig säkerhet • Vänligen använd skyddsglasögon, handskar, säkerhetsskor och hjälm när du monterar odlingsenheten. • Steg 4/7/13: OBS - Bestäm skruvpositionen själv om det inte finns något pilothål. • Varning! Skyddshandskar måste användas.

ES

1 Advertencias y seguridad personal • Por favor, use gafas de seguridad, guantes y zapatos de seguridad y protección para la cabeza cuando instale la jardinera. • Paso 4/7/13: NOTA - Por favor, determine la posición del tornillo por sí mismo en el caso de que no haya un agujero piloto. • ¡Advertencia! Debe usar guantes protectores.

DK

1 Advarsler og personlig sikkerhed • Brug venligst sikkerhedsbriller, handsker, sikkerhedssko og hovedbeskyttelse, når du monterer denne udendørs plantekasse. • Trin 4/7/13: BEMÆRK - Du skal selv bestemme skruens position, hvis der ikke er noget pilot hul. • Advarsel! Beskyttelseshandsker skal anvendes.

NO

1 Advarsler og personvern • Vennligst bruk vernebriller, hansker, vernesko og hodebeskyttelse når du installerer plantemaskinen. • Trinn 4/7/13: MERK - Vennligst finn posisjonen til skruen selv i tilfelle det ikke er noe pilot hull. • Advarsel! Vernehansker må benyttes.

PT

1 Avisos e segurança pessoal • Utilize óculos de proteção, luvas, sapatos de trabalho e proteção para a cabeça durante a instalação do vaso/floreira. • Passo 4/7/13: NOTA - Por favor, determine a posição do parafuso por si mesmo no caso de não haver furo piloto. • Aviso! Deve utilizar luvas de proteção.

RO

1 Avertismente și siguranță personală • Vă rugăm să purtați ochelari de protecție, mănuși, încălțăminte de protecție și protecție pentru cap atunci când instalați jardiniera. • Pasul 4/7/13: NOTĂ - Vă rugăm să determinați singur poziția șurubului în cazul în care nu există o gaură pilot. • Avertisment ! Trebuie să purtați mănuși de protecție.

SI

1 Opozorila in osebna varnost • Prosimo, da med montažo cvetličnega korita nosite zaščitna očala, rokavice, čevlje in zaščito za glavo. • Korak 4/7/13: OPOMBA - V primeru, da ni pilotne luknje, sami določite položaj

vijaka. • Opozorilo! Nositi je treba zaščitne rokavice.

HU

1 Figyelmeztetések és személyi biztonság • Az ültetőgép összeszerelésekor viseljen védőszemüveget, kesztyűt, védőcipőt és fejtetőt. • 4/7/13. lépés: MEGJEGYZÉS - Kérjük, határozza meg a csavar helyét, ha nincs előfúrás. • Figyelmeztetés! Viseljen védőkésztyűt!

CZ

1 Varování a osobní bezpečnost • Při instalaci květináče prosím nosťte a používejte ochranné brýle, rukavice, ochrannou obuv a ochranu hlavy. • Krok 4/7/13: POZNÁMKA - V případě, že není k dispozici pilotní otvor, určete polohu šroubu sami. • Varování! Je třeba nosit ochranné rukavice.

SK

1 Varovania a osobná bezpečnosť • Počas montáže kvetináča používajte ochranné okuliare, rukavice, bezpečnostnú obuv a ochranu hlavy. • Krok 4/7/13: POZNÁMKA - V prípade, že nie je k dispozícii pilotný otvor, určte polohu skrutky sami. • Varovanie! Musíte používať ochranné rukavice.

HR

1 Upozorenja i osobna sigurnost • Molimo vas da nosite zaštitne naočale, rukavice, zaštitne cipele i zaštitu za glavu prilikom postavljanja sadilice. • Korak 4/7/13: NAPOMENA – Molimo odrediti sami položaj vijka ako nema pilot rupe. • Upozorenje ! Moraju se nositi zaštitne rukavice.

FI

1 Varoitukset ja henkilökohtainen turvallisuus • Käytä suojalaseja, hanskoja, turvakengkiä ja päänsuojuksia, kun asennat istutuslutan. • Vaihe 4/7/13: HUOMAUTUS – Määritä ruuvien sijainti itse, jos ohjausreikä ei ole. • Varoitus: On käytettävä suojakäsineitä.

LT

1 Įspėjimai ir asmeninė sauga • Prašome dėvėti apsauginius akinius, pirštines, saugos batus ir galvos apsaugą, kai montuojate sodinimo dėžę. • 4/7/13 žingsnis: PASTABA – Jei nėra pilotinės angos, nustatykite varžto padėtį patys. • Įspėjimas! Turite dėvėti apsaugines pirštines.

GR

1 Προειδοποιήσεις και προσωπική ασφάλεια • Παρακαλούμε να φοράτε προστατευτικά γυαλιά, γάντια, προστατευτικά παπούτσια και προστασία κεφαλής κατά την εγκατάσταση του γλαστριού. • Βήμα 4/7/13: ΣΗΜΕΙΩΣΗ – Παρακαλούμε προσδιορίστε μόνοι σας τη θέση της βίδας εάν δεν υπάρχει οπή οδηγός. • Προειδοποίηση! Πρέπει να φοράτε προστατευτικά γάντια.

BG

1 Предупреждения и лична безопасност • Моля, носете защитни очила, ръкавици, защитни обувки и защита за глава при инсталиране на сандъчето. • Стъпка 4/7/13: ЗАБЕЛЕЖКА – Моля, определете сами позицията на винта, ако няма пилотна дупка. • Внимание! Трябва да се носят защитни ръкавици.

LV

1 Brīdinājumi un personīgā drošība • Lūdzu, valkājiet aizsargbrilles, cimdus, drošības apavus un galvas aizsargu, kad uzstādāt stādītāju. • 4/7/13. solis: PIEZĪME – Lūdzu, pats nosakiet skrūves novietojumu, ja nav vadcauruma. • Brīdinājums! Nepieciešams valkāt aizsargcimdus.

EE

1 Hoiatused ja isiklik ohutus • Palun kandke paigaldamise ajal kaitseprille, kindaid, turvajalaseid ja peakatte kaitset. • Samm 4/7/13: MÄRKUS – Palun määrake kruvi asukoht ise, kui pilootauku pole. • Hoiatust! Kaitsekinnaste kandmine on kohustuslik.

IS

1 Viðvaranir og persónulegt öryggi • Vinsamlegast notaðu öryggisglæraugu, hanska, öryggisskó og höfuðhlíf þegar þú setur gróðurpottinn saman. • Skref 4/7/13: ATHUGIÐ - Vinsamlega ákvarðaðu staðsetningu skrúfunnar sjálfur ef það er ekkert stýrigat. • Varúð! Nota skal öryggishanska.

JP

1 警告と個人の安全 •プランターを設置する際は、保護メガネ、手袋、安全靴と頭部保護具を着用してください。•手順4/7/13：注意 – 下穴がない場合は、ネジの位置をご自身で決めてください。•警告！保護手袋を着用してください

AR

1 التحذيرات والسلامة الشخصية • يرجى ارتداء النظارات الواقية، والقفازات، وأحذية الأمان، وحماية الرأس عند تركيب الحوض الزراعي. • الخطوة 4/7/13: ملاحظة - يرجى تحديد موضع المسمار بنفسك في حالة عدم وجود ثقب تجريبي. • تحذيرا ينبغي أن ترتدي قفازات حماية.

Ce logo Triman est le symbole de recyclage selon le décret français n°2014-1577. Veuillez ne pas jeter ces produits avec vos autres déchets ménagers ou municipaux. S'assurer de toujours profiter de l'occasion pour recycler les déchets d'emballage. Lorsque vous recyclez les déchets d'emballages, vous contribuez à éviter que les produits ne soient incinérés ou envoyés en décharge. Par conséquent, vous contribuez à minimiser l'impact négatif potentiel sur la santé humaine et l'environnement. Le recyclage responsable peut augmenter la réutilisation des ressources matérielles et il évite également les dommages potentiels à l'environnement ou à la santé résultant de l'élimination incontrôlée des déchets.

