

## Quality statement

Alton Furniture Group appreciates your selection of our product. Through our detailed quality checks, we ensure that each box contains exceptional components that will exceed your expectations.

## Customer Service

If your order has missing parts or defective items or if you have any questions, please do not hesitate to contact our customer service department.

## Care Instructions

Please follow the instructions provided below for proper care of your product. Following these tips will ensure your furniture's high-standard quality remains as it ages

- Vacuum regularly to eliminate dust as they can be abrasive and wear the furniture prematurely
- Never use harsh chemicals or solvents as this may damage the finish
- Limit contact with liquids as this may damage the finish
- Bolt spills immediately to prevent staining. If necessary, gently wipe using a clean cloth dampened with warm water. Proceed to brush lightly after drying
- If you choose to use a professional product, test the fabric in a discreet area for any signs of defect
- Stains from markers, pens, crayons, and pens may be difficult to remove. We recommend that you consult a professional

# IMPORTANT !

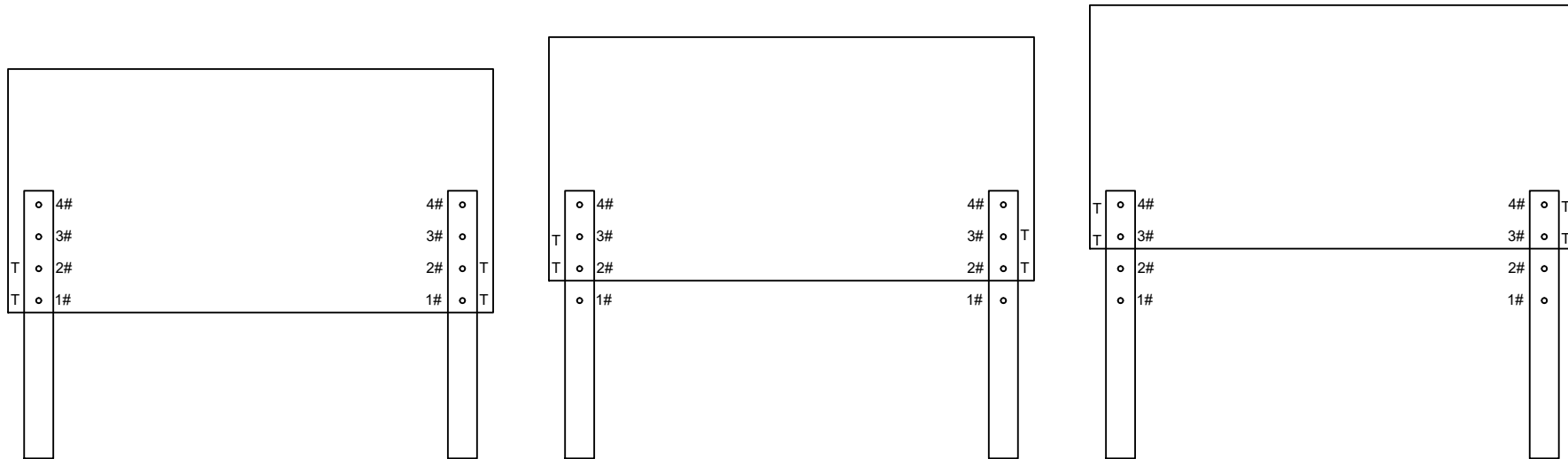

Please check the thickness of your mattress and box spring before proceeding.



BOX Spring +Mattress	Adjustable Headboard Height
10"	T match 1#
14"	T match 2#
18"	T match 3#
22"	T match 4#

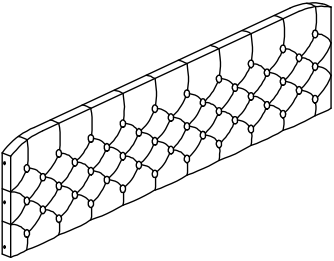
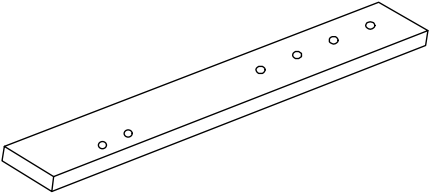
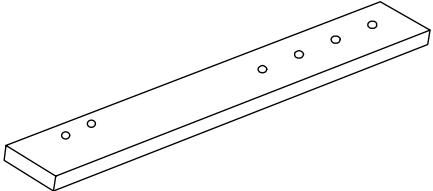
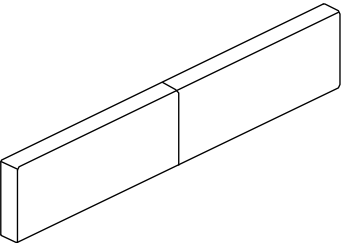
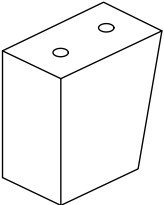
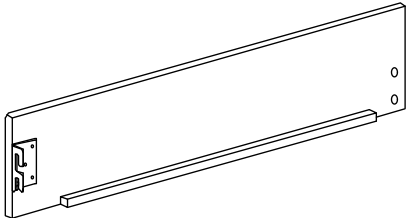
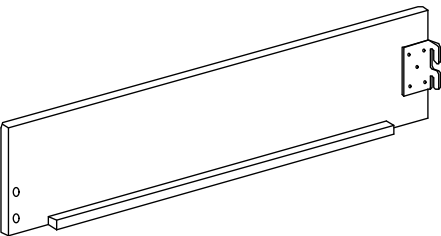
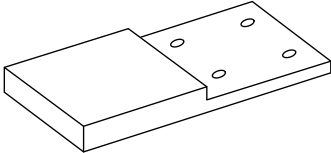
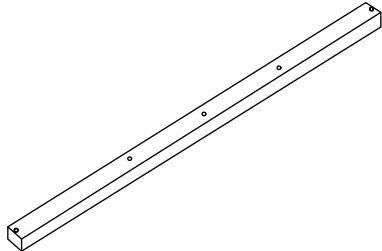

# PARTS LIST

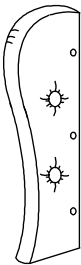
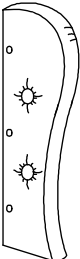
PLEASE CHECK TO ENSURE ALL PARTS ARE IN THE BOX

A	1PC	L	1PC	R	1PC
Headboard Panel		Left Headboard Leg		Right Headboard Leg	
					
B	1PC	C	2PCS	D	2PCS
Footboard Panel		Feet		Side Rails	
					
E	2PCS	F	2PCS	G	4PCS
Side Rails		Side Rail Support Legs		Slats	
					
H	12PCS	J	1PC	K	1PC
Support Legs		Left Wingback		Right Wingback	
					

# HARDWARE LIST

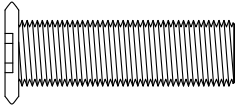
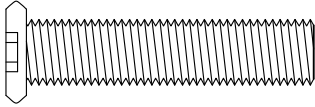
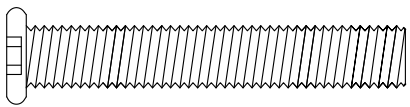
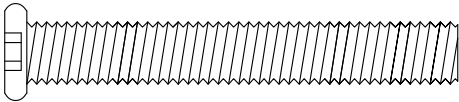
PLEASE CHECK TO ENSURE ALL PARTS ARE IN THE BOX

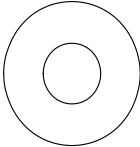
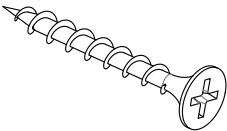
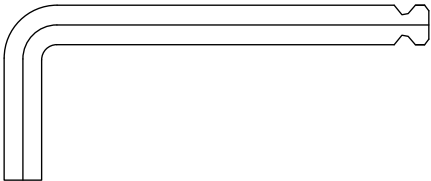

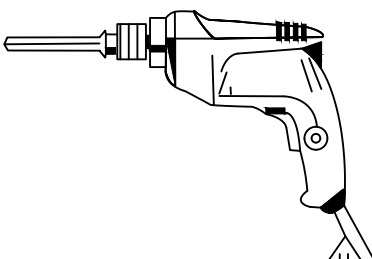

①	28PCS	②	6PCS	③	4PCS
Allen Bolts Ø 5/16" x 1 1/8"		Allen Bolts Ø 5/16" x 1 1/2"		Allen Bolts Ø 5/16" x 2"	
					
④	2PCS	⑤	2PCS	⑥	18PCS
Allen Bolts Ø 5/16" x 2 1/4"		Wood Dowel Ø5/16" x 1 1/8"		Spring Washers Ø 5/16" x 9/16"	
					
⑦	18PCS	⑧	8PCS	⑨	1PC
Flat Washers Ø 5/16" x 3/4"		Screw F4 x 1 1/4"		Allen Wrench M5 x 2 1/2"	
					

This page lists all contents included in the box. Please take the time to identify the hardware, as well as, the individual components to this product. As you unpack and prepare for assembly, place the contents on a well-padded area to protect them from damage.

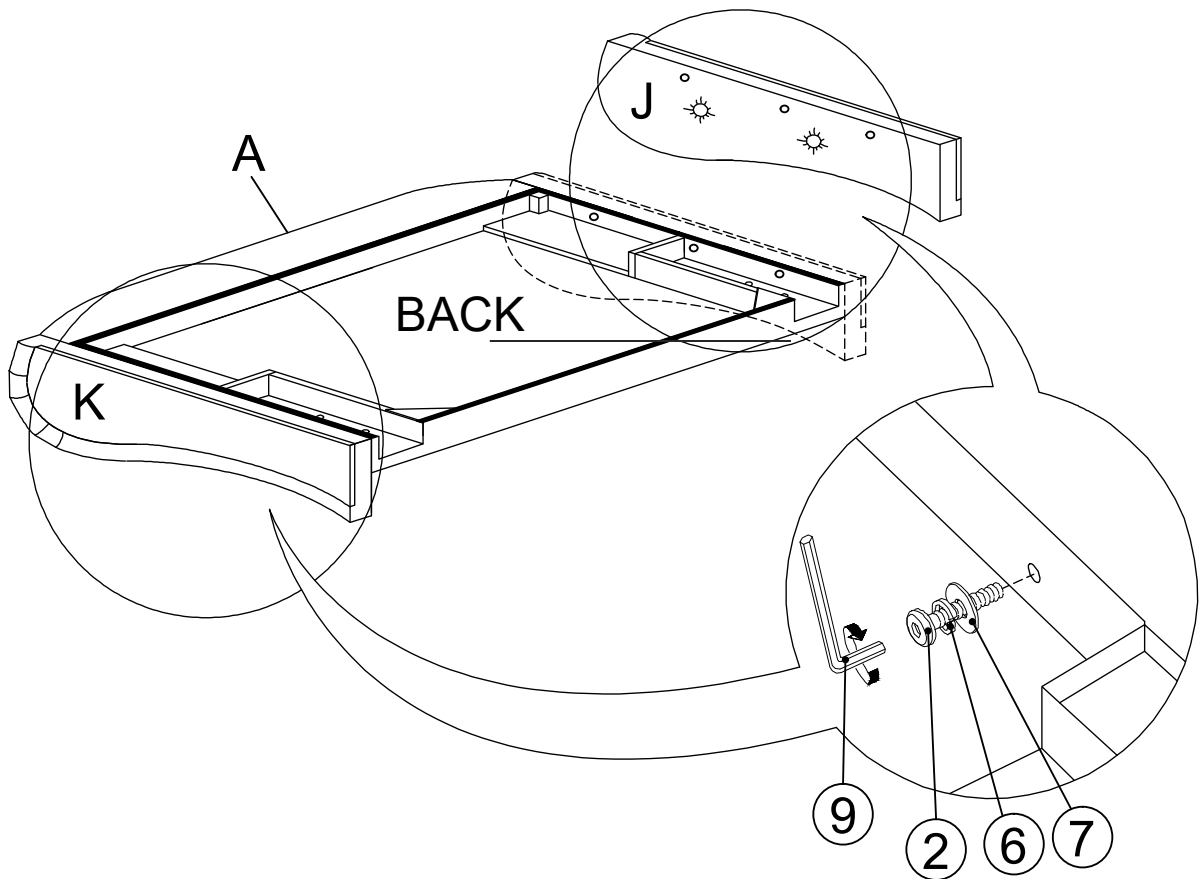

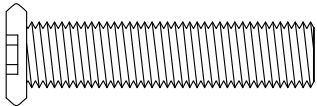
Electric drill (not included) is recommended to tighten the wood screws

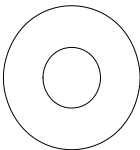

②	6PCS	⑥	6PCS
Allen Bolts $\text{\O} 5/16'' \times 1 \frac{1}{2}''$		Spring Washers $\text{\O} 5/16''$	
			
⑦	6PCS	⑨	1PC
Flat Washers $\text{\O} 5/16'' \times 3/4''$		Allen Wrench M5 x 2 1/2"	
			

Tips:

\*\*Please check the thickness of your mattress and box spring before proceeding.

2)



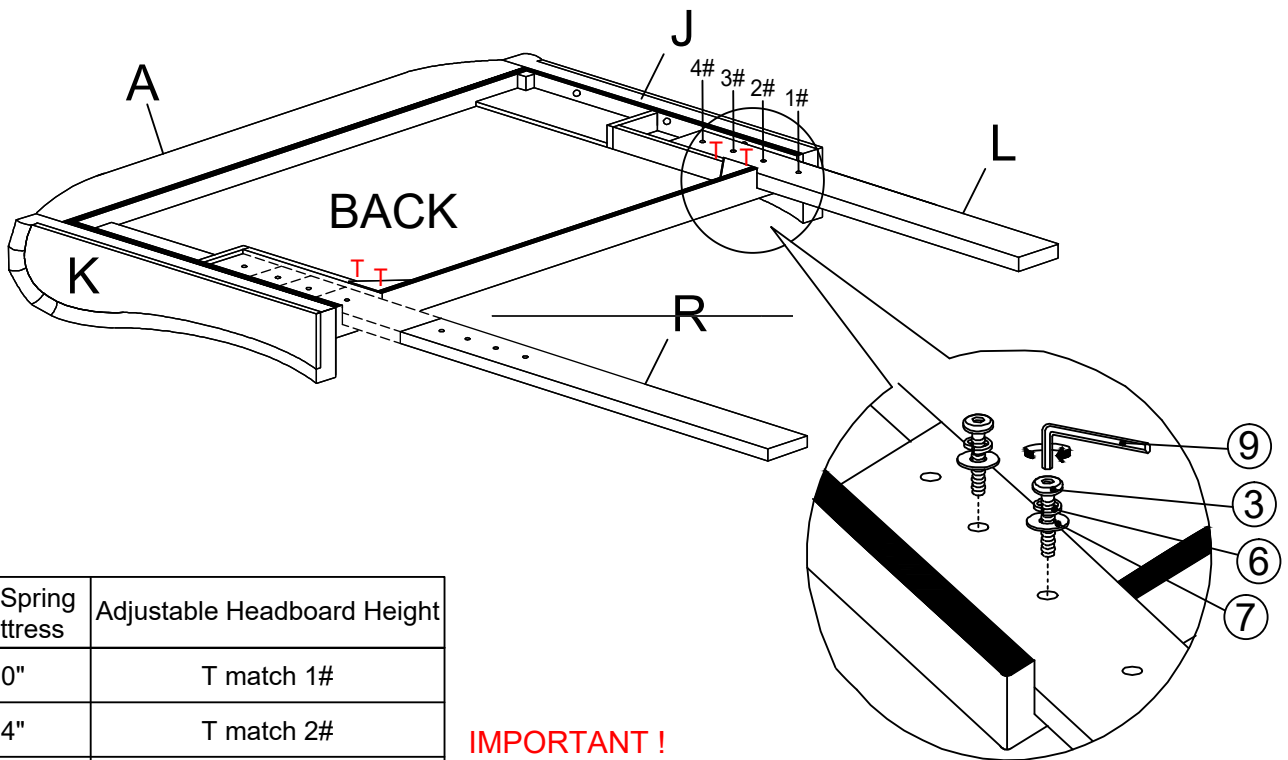

Assemble the Headboard Panel (A) and the Legs (R & L).

(DO NOT FULLY TIGHTEN BOLTS AT THIS STEP.)

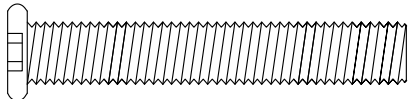

**IMPORTANT !**  
Please check the thickness of your mattress and box spring before proceeding.

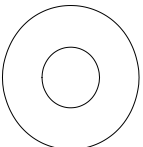
BOX Spring +Mattress	Adjustable Headboard Height
10"	T match 1#
14"	T match 2#
18"	T match 3#
22"	T match 4#

③	4PCS	⑥	4PCS
Allen Bolts Ø 5/16" x 2"		Spring Washers Ø 5/16"	
			
⑦	4PCS	⑨	1PC
Flat Washers Ø 5/16" x 3/4"		Allen Wrench M5 x 2 1/2"	
			

3)  
Assemble the Footboard (B) & Feet (C).

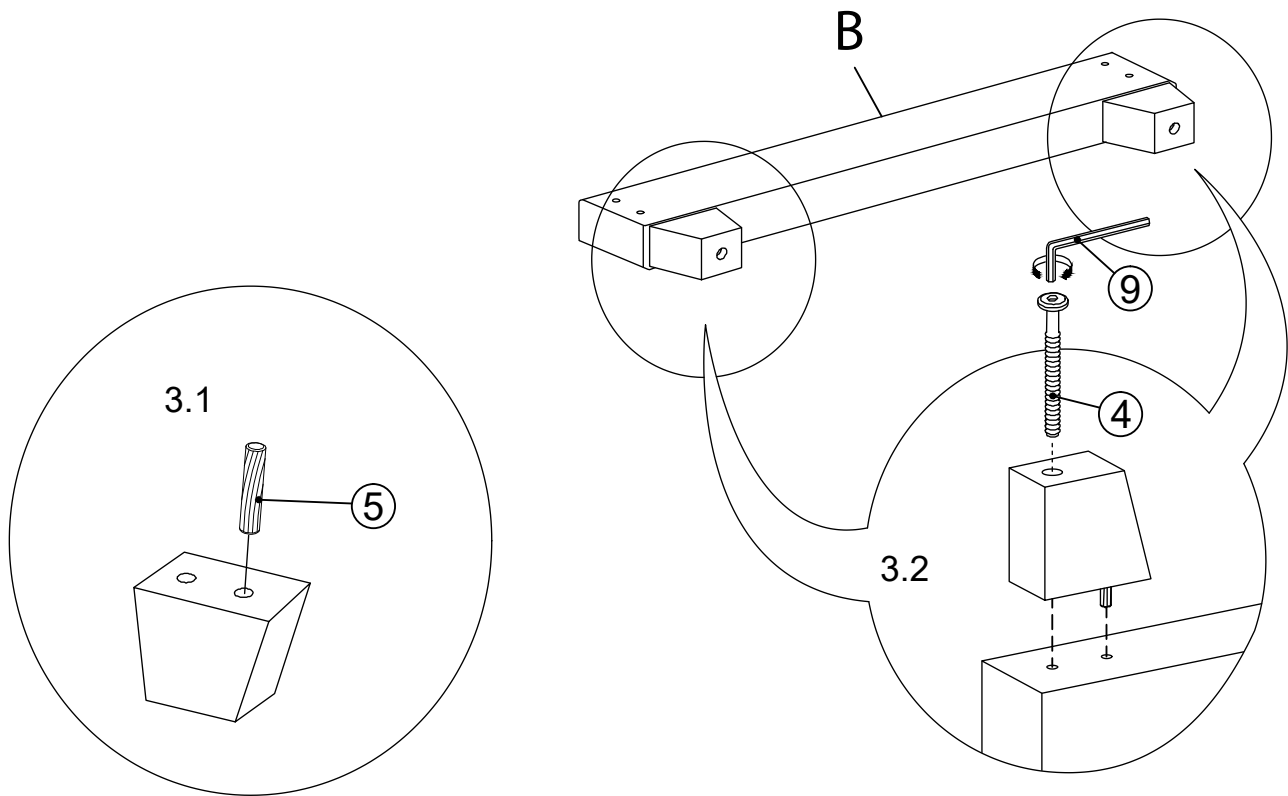

④

2PCS

Allen Bolts Ø 5/16" x 2 1/4"

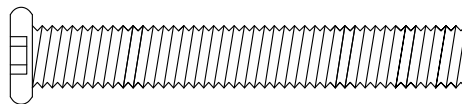

⑤

2PCS

Wood Dowel Ø5/16" x 1 1/8"



⑨

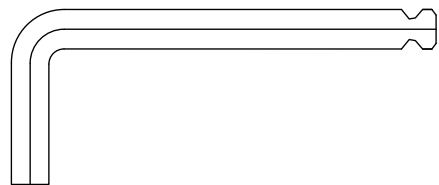

1PC

Allen Wrench M5 x 2 1/2"



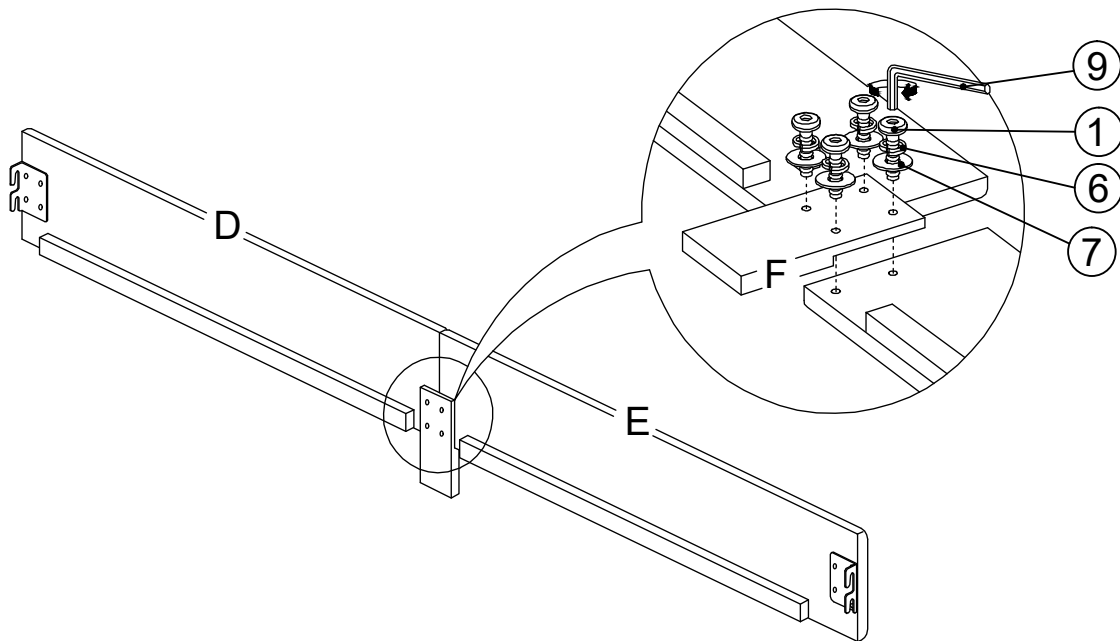

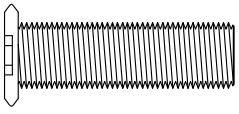
4)  
Join side rail (D) and (E) together with the side rail support legs (F).

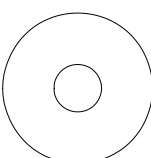
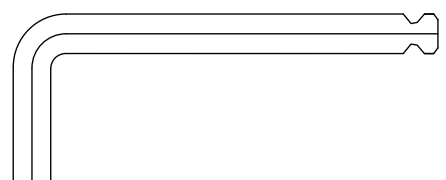

①	8PCS	⑥	8PCS
Allen Bolts Ø 5/16" x 1 1/8"		Spring Washers Ø 5/16" x 9/16"	
			
⑦	8PCS	⑨	1PC
Flat Washers Ø 5/16" x 3/4"		Allen Wrench M5 x 2 1/2"	
			

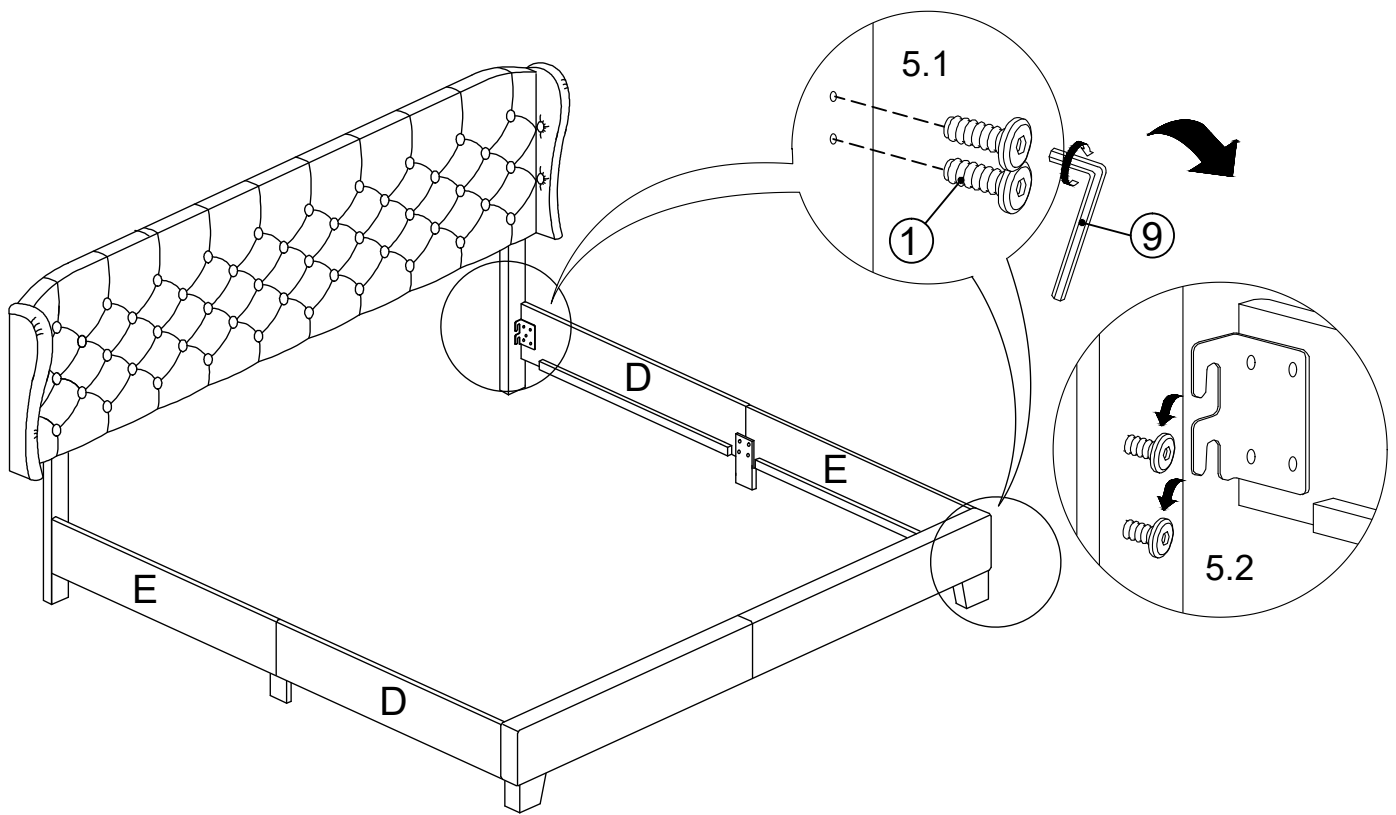
5)  
 Attach loosely hardware (1) to the Headboard Legs (L) &(R) and Footboard (B). Then attach Side Rail (D) & (E) to the Headboard Legs and Footboard by pushing the bracket down, ensuring it locks into hardware (1).

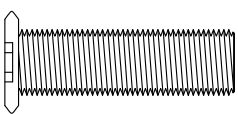

①	8PCS	⑨	1PC
Allen Bolts Ø 5/16" x 1 1/8"		Allen Wrench M5 x 2 1/2"	
			

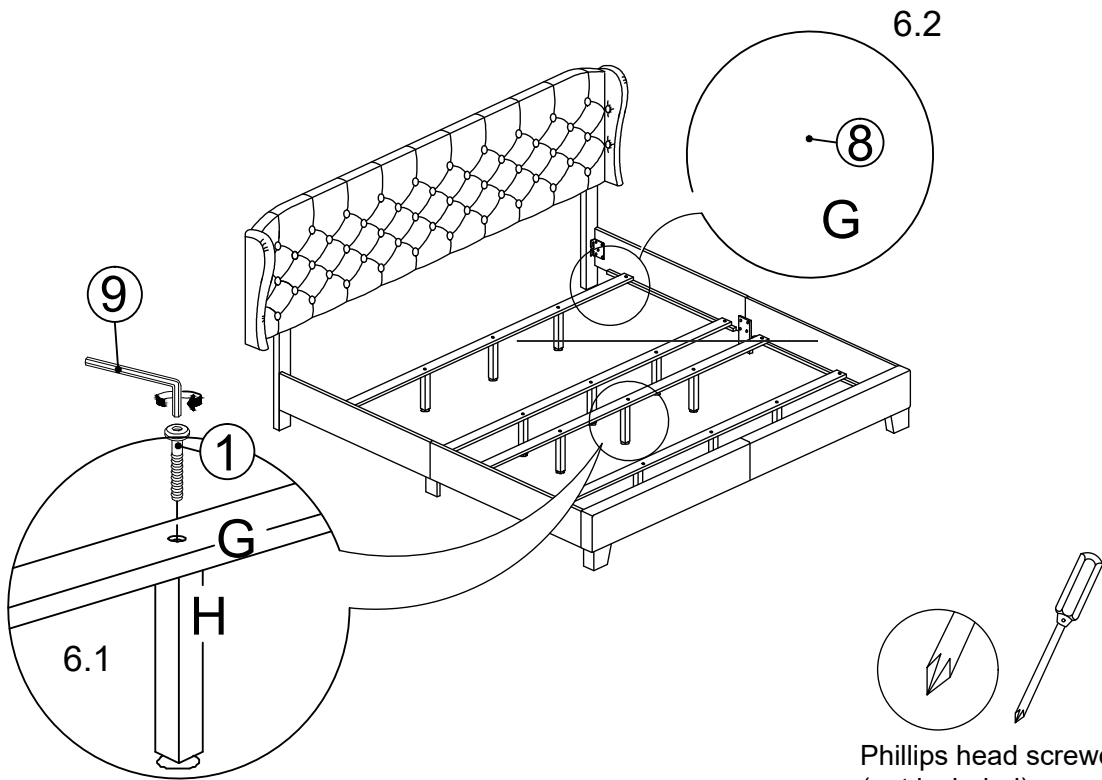

Phillips head screwdriver / Electric drill  
(not included) are necessary for assembly  
Use the phillips head screwdriver to  
tighten the wood screw

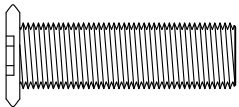
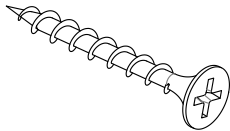
①	12PCS	⑧	8PCS
Allen Bolts Ø 5/16" x 1 1/8"		Screw F4 x 1 1/4"	
			
⑨		1PC	

Allen Wrench M5 x 2 1/2"

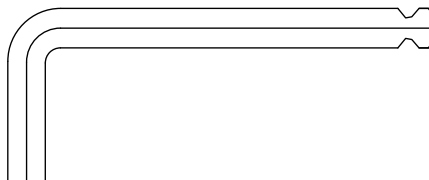

Adjust the unit to be evenly aligned, then secure all bolts tightly.  
Close the fabric lining behind the headboard.

