

# Instruction Manual

## User Guide

### Make life better

Warm tips: We are proud of high-quality products and satisfactory service, but the goods may encounter special circumstances during transportation, if you receive the goods with missing or damaged parts, please take photos and contact our customer service before returning the goods , we will customize a solution that satisfies you, thank you.

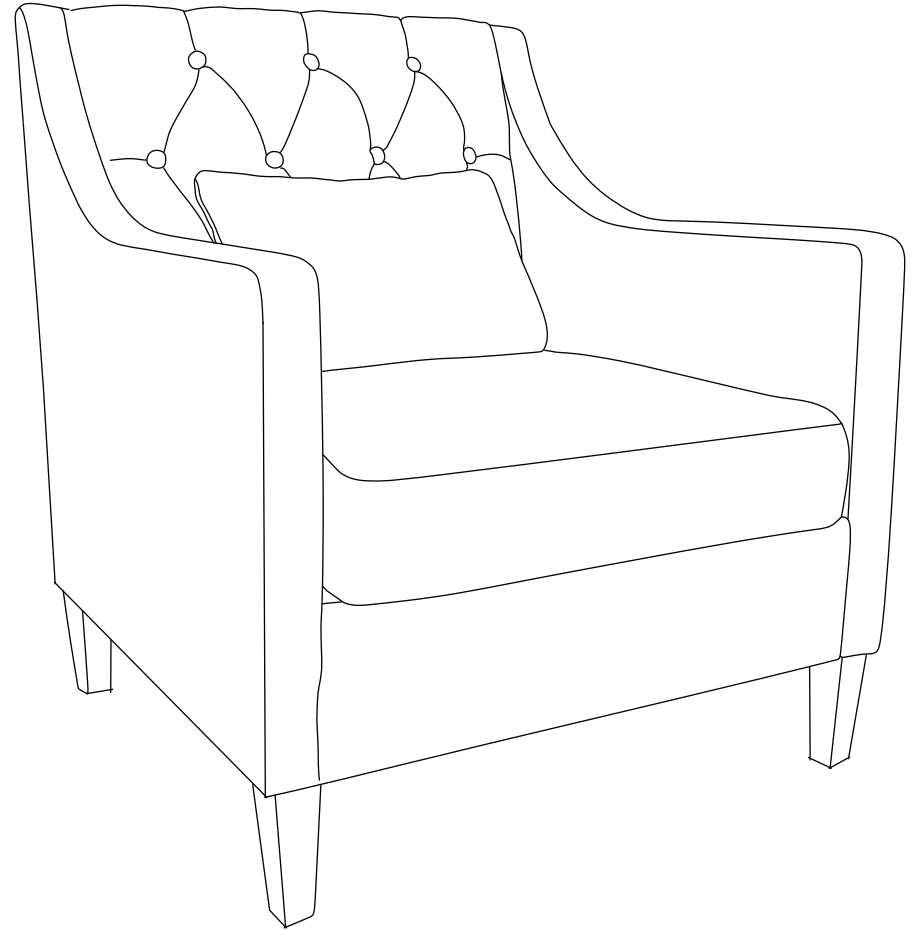

#### Note:

1. During the assembly process of a product, if you need to install multiple screws, you can first align all the screws with the holes, first rotate a few times to fix the positions of all the screws, and after all the screws are aligned with the holes, use a wrench to completely Tighten in turn.
2. Flat washers and lock washers must be installed to prevent the screws from loosening and damaging the joints.

**ACCENT CHAIR**

# Instruction

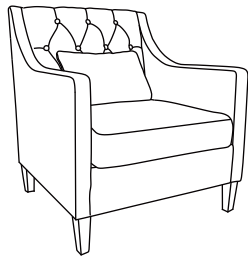

◀ ACCENT CHAIR

▼ PARTS LIST

NO	DESCRIPTION		QTY
A	Backrest		1
B	Cushion		1
C	Left armrest		1
D	Right armrest		1
E	Sitting board		1
F	Front rail		1
G	Pillow		1
H	Leg		4
I	Leg spacer		4
J	Long screw	Φ5/16 "2-3/8" L	2
K	Short screw	Φ5/16 "1-3/16" L	4
L	Flat pad	Φ5/16 "22mm	6
M	Spring washers	Φ5/16 "6	6
N	Spanner	Φ5mm	1

# Installation Method

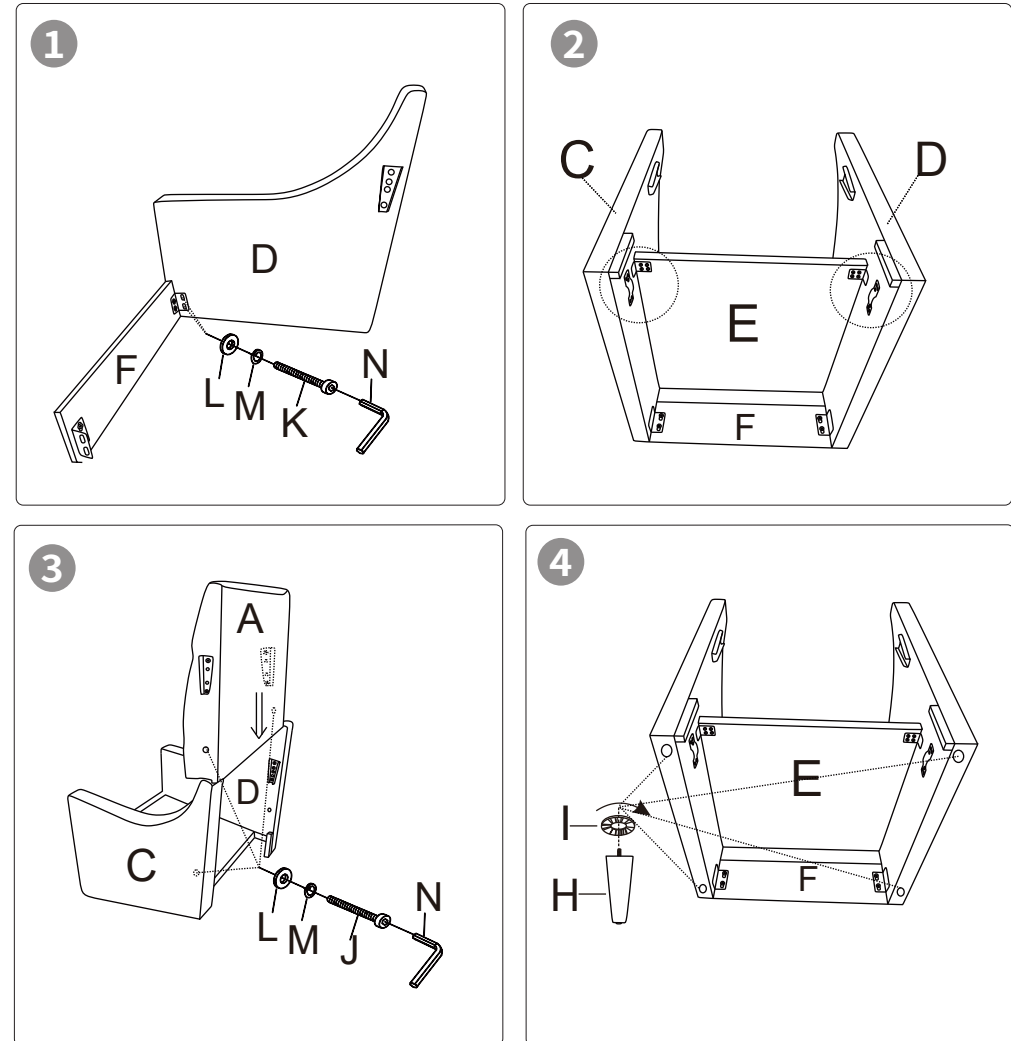

- As shown in the picture, first connect D and F, C and F, and screw in the screws according to the arrangement of the parts as shown in the picture.
- Insert E into the corresponding slots of C and D
- Insert A into the assembled parts, use screws to align the holes on both sides of A, C, and D at the same time, screw the screws in half, make sure that the holes on both sides can be inserted into the screws, and then tighten.
- Put the I set on H, and then tighten the legs clockwise.
- Tear off the Velcro strip at the back of the seat bag, and install B on E