

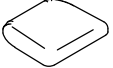

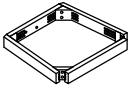

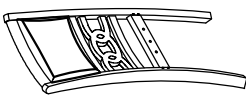



ASSEMBLY INSTRUCTIONS

DINING CHAIR

Thank you for purchasing this product. Please take time to read and follow the instructions below. Check that you have all parts and hardware before assembly. Parts apparently missing are often found in the packing materials. If you do not have all the parts listed, have your dealer contact us and they will be sent to you immediately.

 It is recommended to install protective pads under all legs and supports to avoid damage or scratches when placing furniture on or other hard surface, and to limit indentation and prevent discoloration if placing on carpet.

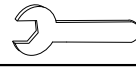
PART LIST			
A		Cushion Seat	4
B		Seat Frame	4
C		Chair Back	4
D		Front Legs	8

HARDWARE LIST				
1		Lock Washers	5/16" x 6/8" x 0.08"	44
2		Flat Washers	5/16" x 1/2" x 0.08"	44
3		Bolts	1/4" x 45mm	12
4		Bolts	1/4" x 75mm	16
5		Nuts	5/16"	16
6		Allen Wrench	5/16"	1
7		Wood screws	#4 x 38mm	24

HARDWARE SET ARE PACKED IN SH1155 FOR ASSEMBLY

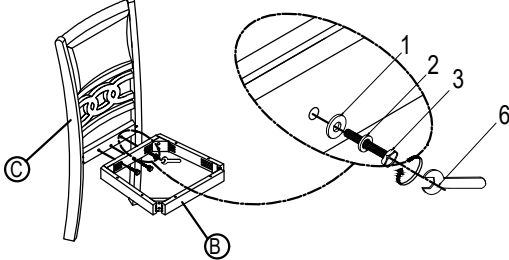
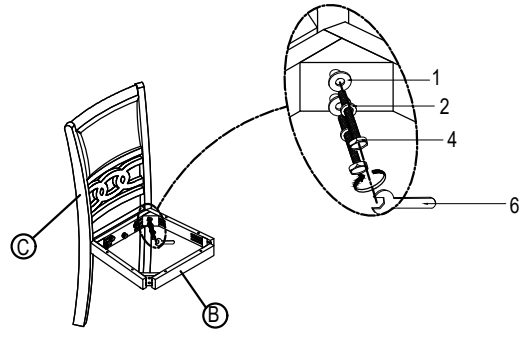
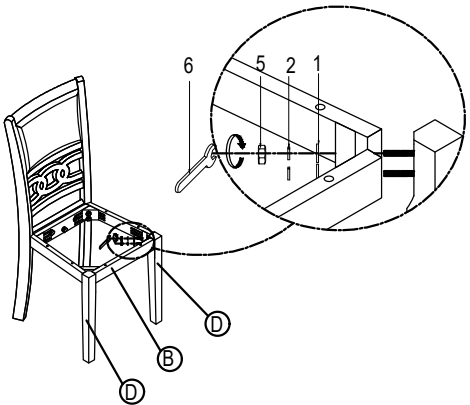
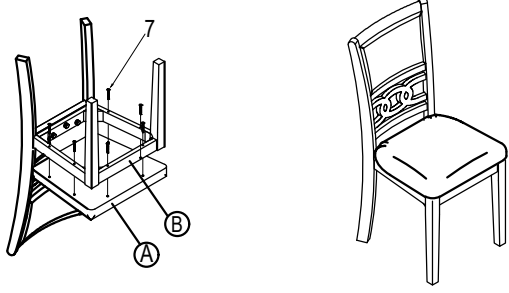
<p>STEP 1</p> 	<p>STEP 2</p> 
<p>STEP 3</p> 	<p>ASSEMBLY COMPLETED</p> 

DO NOT TIGHTEN BOLTS UNTIL COMPLETELY ASSEMBLED

MADE IN VIETNAM