

Instruction Manual

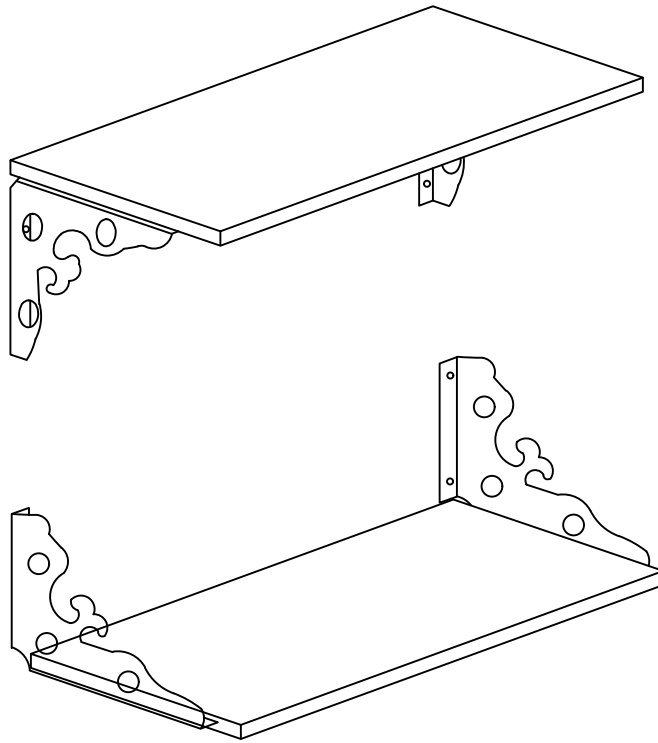

DEAR CUSTOMER,

Thank you for choosing our product. Please read this manual carefully before assembling. If the product is passed on to the third party, this manual has to be passed on along with the product. Enjoy your new purchase!





Assemble Item On a Clean Flat Surface



Tools Required For Assembly



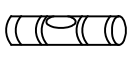

HARDWARE LIST

1  ×8pcs	2  ×8pcs	3  ×8pcs	4  ×8pcs	5  ×1pcs
---	---	---	---	---

PARTS LIST

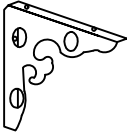
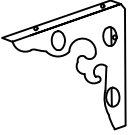
Note: there will be some error in the measurement, the actual size shall prevail.

<p>A</p>  <p>×2pcs</p>	<p>B</p>  <p>×2pcs</p>	<p>C</p>  <p>×2pcs</p>	<p>D</p>
--	--	---	-----------------

NOTE

- Please check that you have all the parts and hardware listed before assembling.
- Please do not tighten all bolts until the table is assembled completely.
- If you find that something is missing, please contact the store you purchase immediately.
- At least every 4 months, check all bolts, screws and knobs to be sure they are tight.

Step:1

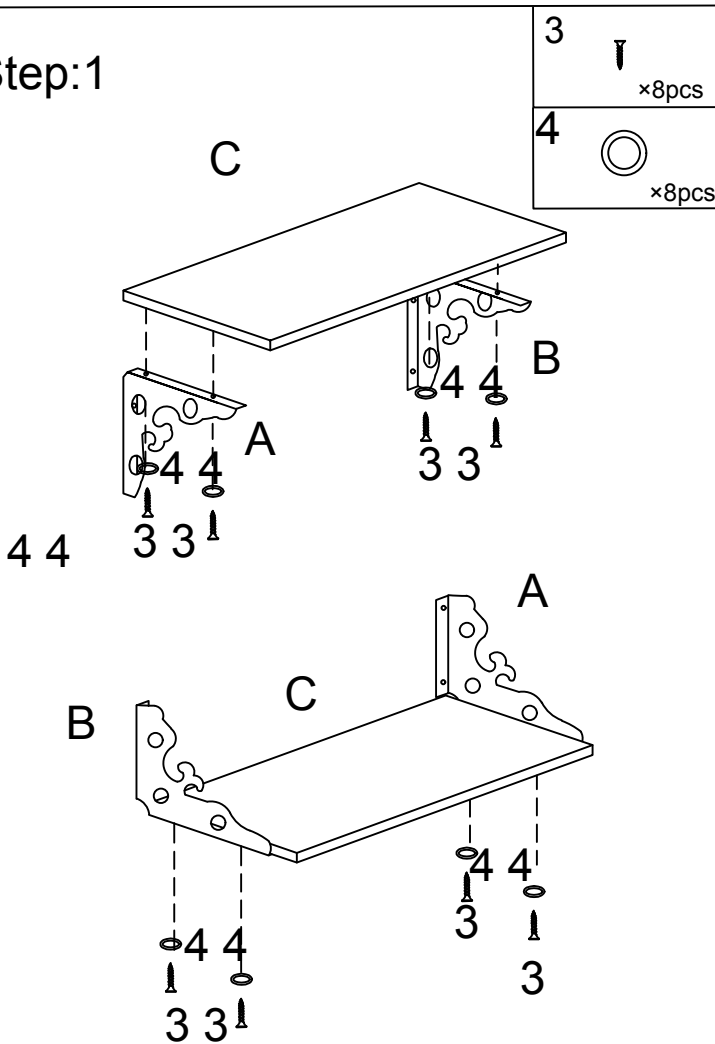

Step:2

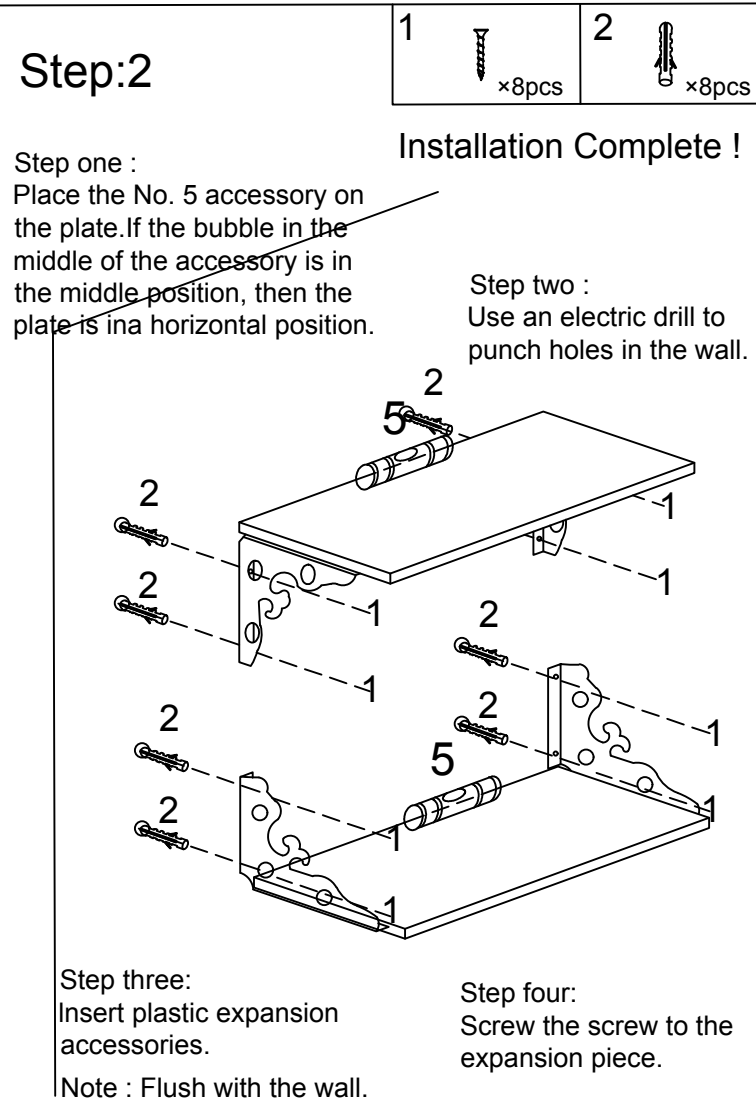

5

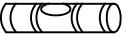

×1pcs

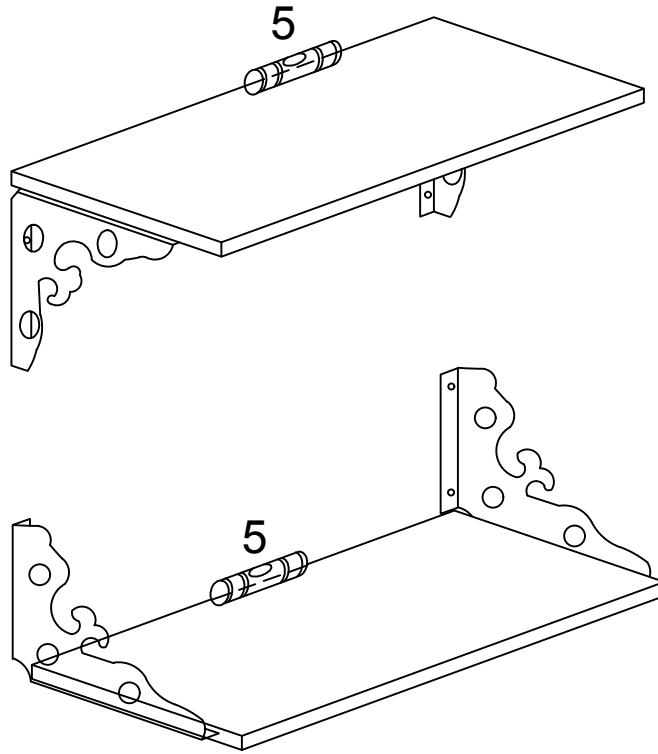

Place the No. 5 accessory on the plate. If the bubble in the middle of the accessory is in the middle position, then the plate is in a horizontal position.