

# ASSEMBLY INSTRUCTIONS

## 5-PC DINING SET

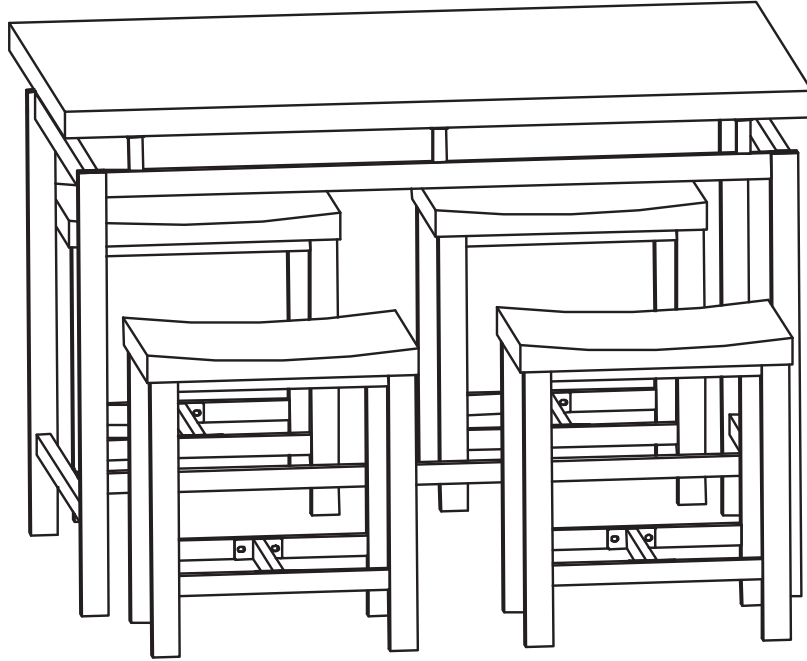

ASSEMBLY  
REQUIREMENTS

2-Person  
Assembly

2 Hours  
Assembly Time  
(Approximate)

Thank you for purchasing our product!

Please refer and use this assembly instruction to assemble the product. Contact our customer service department in case there are any missing or damage parts or hardware. Replacement parts are normally shipped within 2 or 3 days.

**PRODUCTS PURCHASED THROUGH OUR AUTHORIZED VENDORS ONLY ARE ELIGIBLE FOR REPLACEMENT PARTS.**

We appreciate your business!

**THIS PRODUCT IS FOR INDOOR AND HOUSEHOLD USE ONLY- NOT FOR COMMERCIAL USE.**

# ASSEMBLY INSTRUCTIONS

## 5-PC DINING SET

### ASSEMBLY PREPARATION

- Remove all packaging materials, staples and packing straps from the carton.
- Refer to Parts List and Hardware List, and ensure parts and hardware are correct before assembly. Contact customer service for missing parts.
- Place all wooden parts on a clean, flat and soft surface (e.g. carpet or rug) to prevent parts from getting scratched.

### SAFETY PRECAUTION

1. KEEP ALL HARDWARE PARTS OUT OF REACH OF CHILDREN.
2. DISPOSE PLASTIC PACKAGING MATERIAL IMMEDIATELY TO AVOID ANY RISK OF SUFFOCATION TO CHILDREN AND ANIMALS.



### TIPS FOR ASSEMBLY

1. Allow ample room for assembly and in close proximity to where product will be placed.
2. Assemble the product on a surface that does not scratch or damage the exterior gloss and finish of the furniture.
3. Identify all of the parts, hardware and quantities required for each step.
4. During assembly, do not over-tighten any fittings as this may cause damage.
5. DO NOT USE POWER TOOLS TO ASSEMBLE THIS PRODUCT.
6. Always place the product on a flat, level surface.
7. Do not sit or stand on the partially assembled product; only use the product for which it is intended.

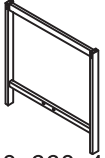
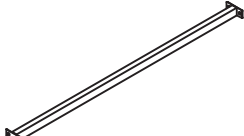
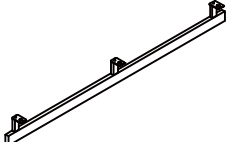
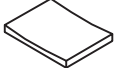
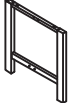

### CARE AND MAINTENANCE

- Use a slightly damp cloth to clean the product. Do not use bleach or abrasive cleaning material.
- Check all the fittings periodically and re-tighten as necessary. Do not use the product if any of the parts is damaged or broken.
- Never allow any kind of liquid to remain on your furniture. Absorption can cause wood to warp or delaminate.
- Do not place hot items (e.g. hot drinks) directly onto the wood surface.
- Do not drag and/or pull the furniture.

## Parts List

A	 1100x700x40mm Table Top	x1
B	 660x660x40mm Table Side Frame	x2
C	 1001x70x30mm Table Bottom Support Bar	x1
D	 980x90x40mm Table Cross Bar	x2
E	 400x300x40mm Stool Seat	x4
F	 390x410x20mm Stool Side Frame	x8
G	 254x60x16mm Stool Cross Bar	x4
H	 257x70x30mm Stool Bottom Support Bar	x4

## Hardware List

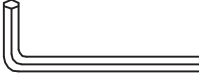
1	 M6x60mm Long Bolt	x8
2	 M6x30mm Medium Bolt	x16
3	 M6x12mm Short Bolt	x42
4	 M6 Allen Key	x1

## Step 1

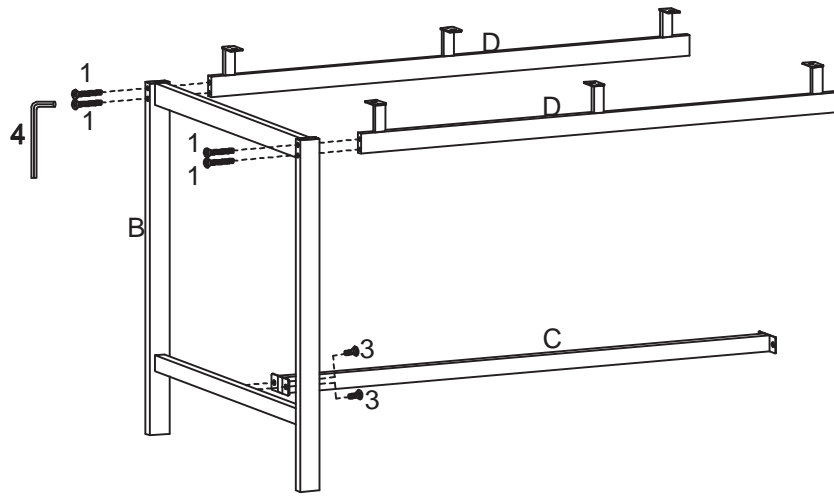

With assistance, fasten 2x Table Cross Bar (D) and Table Bottom Support Bar (C) to a Table Side Frame (B) with Long Bolt (1) and Short Bolt (3), respectively. Use Allen Key (4) to drive (1) and (3). Do not tighten bolts completely until both bolts are in place on each part.

## Step 2

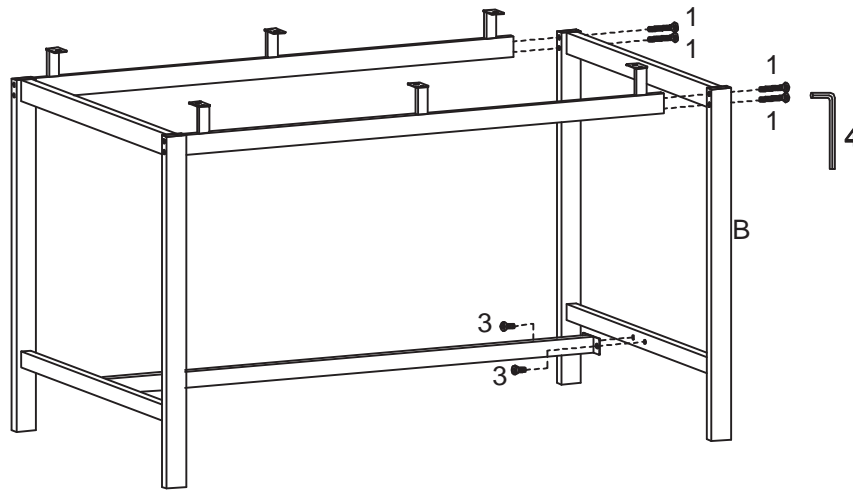

With assistance, fasten remaining Table Side Frame (B) to 2x Cross Bar (D) and Bottom Support Bar (C) with Long Bolt (1) and Short Bolt (3), respectively. Use Allen Key (4) to drive (1) and (3). Do not tighten bolts completely until both bolts are in place on each part.

## Step 3

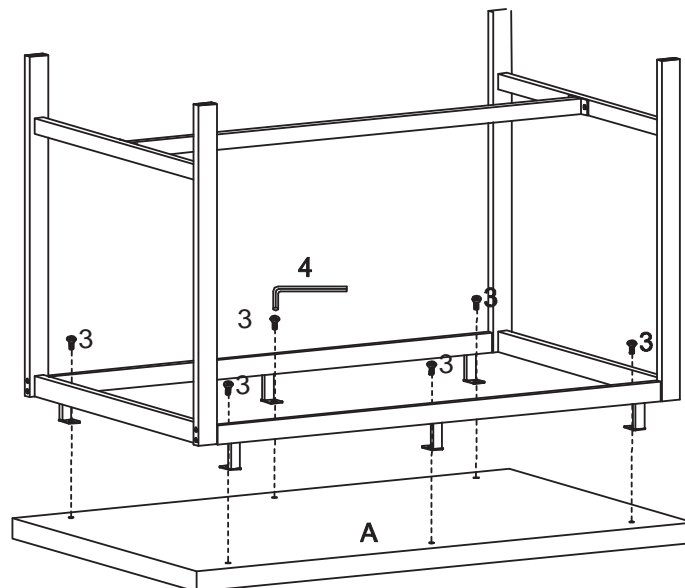

With assistance, lay Table Top (A) flat with the bottom-side facing up and align bolts holes on each part. Use Short Bolt (3) to fasten (A) to Cross Bar. Use Allen Key to drive (3). Do not tighten the bolts completely until all of the bolts are in place.

Set the table right-side up. The assembly of the table is complete.

## Step 4

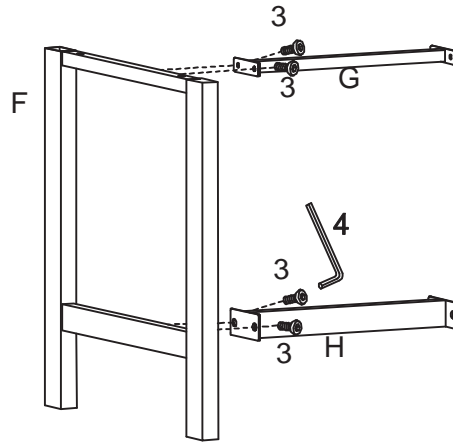

With assistance, fasten Stool Cross Bar (G) and Stool Bottom Support Bar (H) to a Stool Side Frame (F) with Short Bolt (3)

Use Allen Key (4) to drive (3). Do not tighten bolts completely until both bolts are in place on each part.

## Step 5

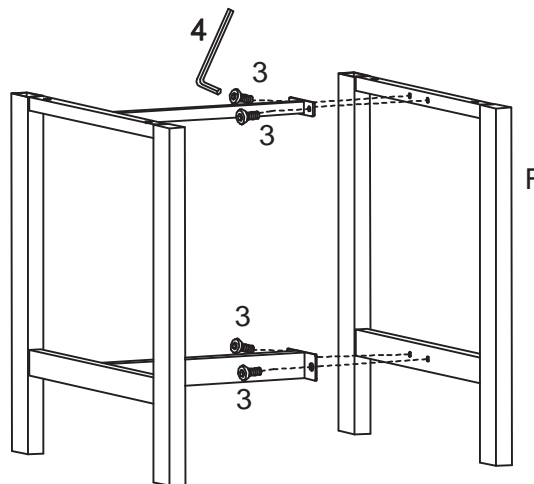

With assistance, fasten remaining Stool Side Frame (F) to Stool Cross Bar and Bottom Support Bar with Short Bolt (3).

Use Allen Key (4) to drive (3). Do not tighten bolts completely until both bolts are in place on each part.

## Step 6

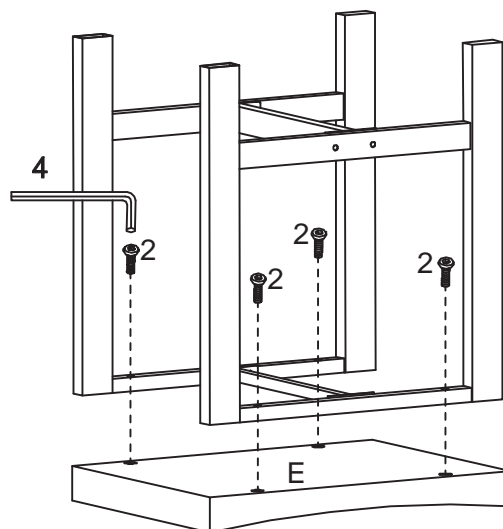

Lay Stool Seat (E) flat with the bottom-side facing up and align bolts holes on Seat Side Frame to bolt holes on (E). Use Medium Bolt (2) to fasten (E) to Stool Side Frame. Use Allen Key to drive (2). Do not tighten the bolts completely until all of the bolts are in place.

Set the stool right-side up. The assembly of the stool is complete.