

ASSEMBLY INSTRUCTIONS

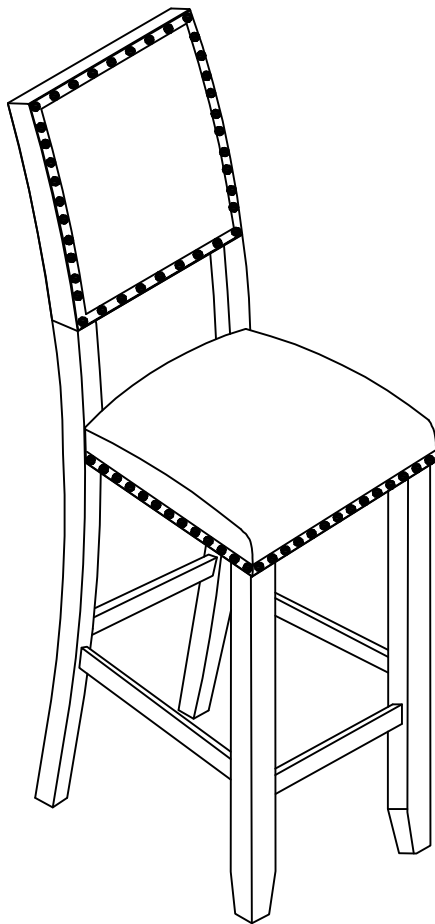

TOOLS REQUIRED



Allen Wrench

(Included)



2 - People
Recommended

ASSEMBLY RATING

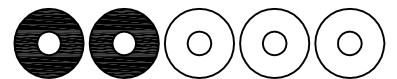

EASY —————> DIFFICULT

The Assembly Rating is a 5-point system showing the level of effort needed to assemble a specific product.

PRE ASSEMBLY INTRODUCTION

We understand building ready-to-assemble furniture can be a challenging experience for some. To help avoid confusion, we have provided some helpful tips that may speed up the process.

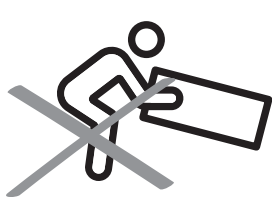

Teamwork

ALWAYS have at least two people to help with transporting and assembling the product to avoid potential injury and/or damage.

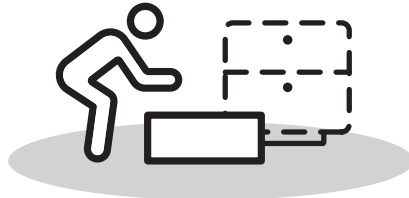
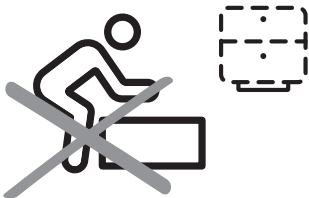

Suitable Location

Assembling near the area of the intended location is highly recommended.



Sufficient Space

Make sure you have enough space to move around during the assembly.

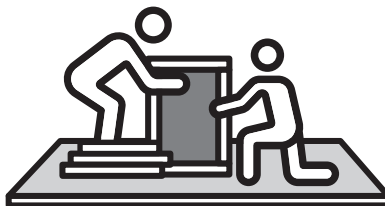

Avoid Scratches

Use cardboard, blankets or a carpeted area while assembling furniture to prevent scratches.

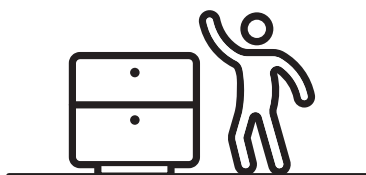

Flat Surface

Make sure the furniture rests on a flat and level surface with each leg evenly touching the floor.

ASSEMBLY AND CARE ADVICE



FAILURE TO FOLLOW THE GUIDELINES BELOW MAY RESULT IN INJURY AND/OR PROPERTY DAMAGE.



Position each part correctly and insert screws or bolts into their respective holes.

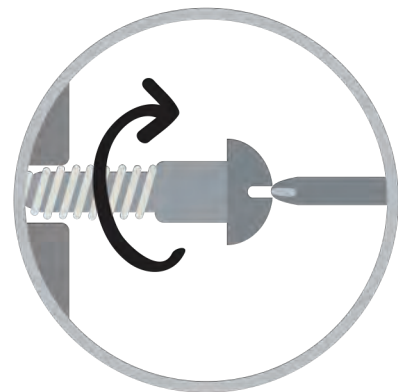

Turn clockwise to tighten and only tighten when step is completed or when instructed to do so.



Use the appropriate hand tools or power tools for assembly. Select steps, such as tightening screws and/or bolts, may require hand tools to avoid causing damage during assembly.



Save the instructions and store any supplied tools for later maintenance.

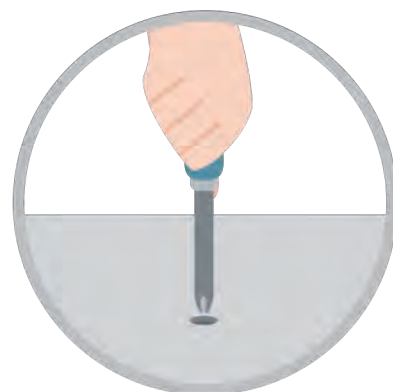

After two weeks, check and tighten any loose hardware and repeat again every six months thereafter.

IT IS THE USER'S RESPONSIBILITY TO MAINTAIN THE FURNITURE. THE HARDWARE MAY LOOSEN OVER TIME AND MAY CAUSE THE FURNITURE TO BE WOBBLY AND UNABLE TO SUPPORT ITS INTENDED WEIGHT CAPACITY. THIS MAY LEAD TO COLLAPSE AND MAY CAUSE SERIOUS INJURY.

CHAIR

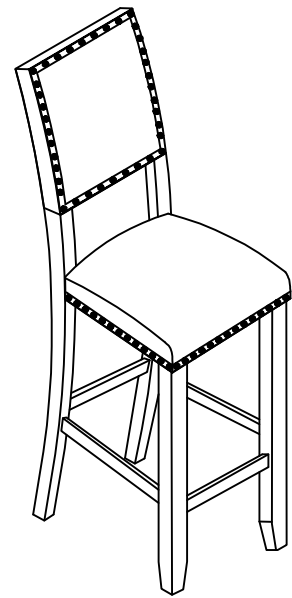
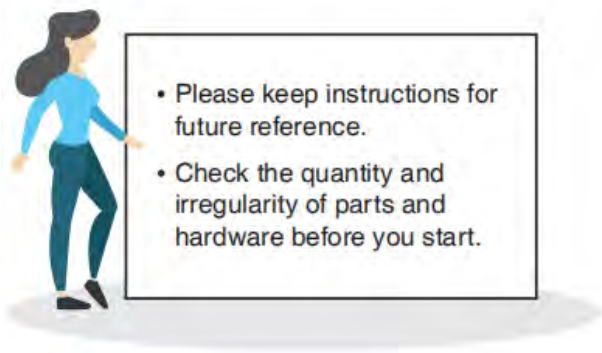

x 2

PARTS

#1 1pc x 2

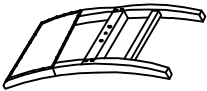

Backrest W/Legs

#2 1pc x 2

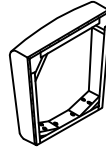

Seat

#3 2pcs x 2

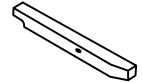

Front Leg (L & R)

#4 2pcs x 2

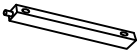

Leg Support (L & R)

#5 1pc x 1

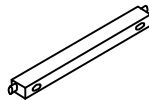

Front Leg Support

HARDWARE

#A 10pcs x 2

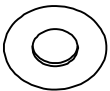

Flat Washer

#B 10pcs x 2



Lock Washer

#C 4pcs x 2

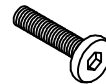

Bolt Ø5/16" x 3-1/4"

#D 2pcs x 2



Bolt Ø5/16" x 1-1/2"

#E 4pcs x 2

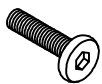

Bolt Ø5/16" x 2-1/2"

#F 1pc x 2

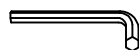

Allen Wrench M5

#G 6pcs x 2



Wood Screw Ø8*1-3/4"

ASSEMBLY INSTRUCTIONS

- I. Align the seat (#2) to the backrest with legs (#1).
- II. Prepare 2 bolt assemblies by FIRST inserting the lock washer (#B) onto the bolt (#D) then the flat washer (#A) onto that SAME bolt (#D). Secure using the Allen wrench (#F).

1

Part (#1) x1pc

Part (#2) x1pc

Hardware (#A) x 2pcs

Hardware (#B) x 2pcs

Hardware (#D) x 2pcs

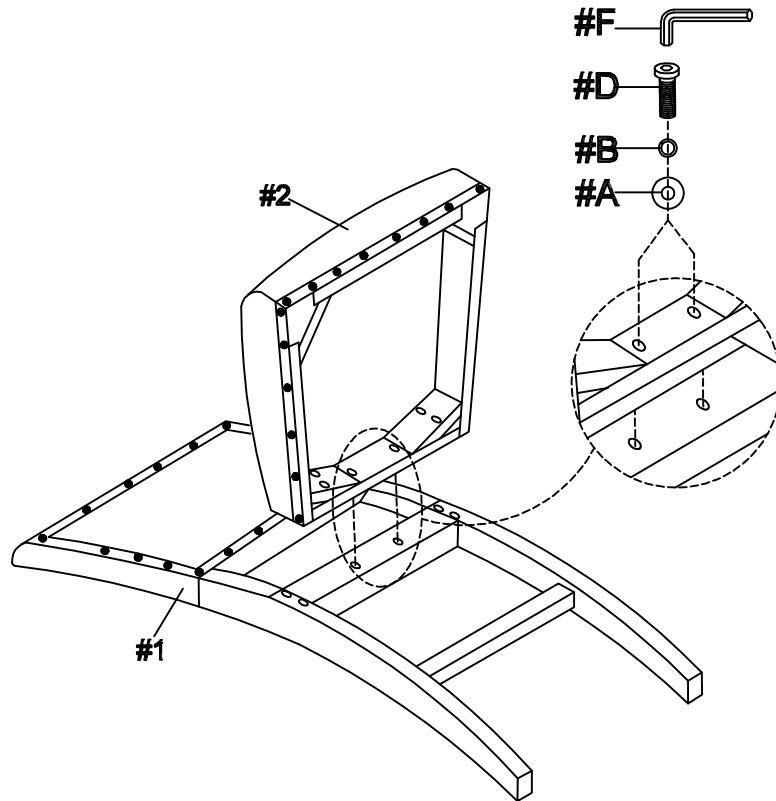

2

Hardware (#A) x 4pcs

Hardware (#B) x 4pcs

Hardware (#C) x 4pcs

- Prepare 4 bolt assemblies by FIRST inserting the lock washer (#B) into the bolt (#C) then the flat washer (#A) onto that SAME bolt (#C). Insert bolt assemblies into the corners of the seat (#2) and secure using the Allen wrench (#F).

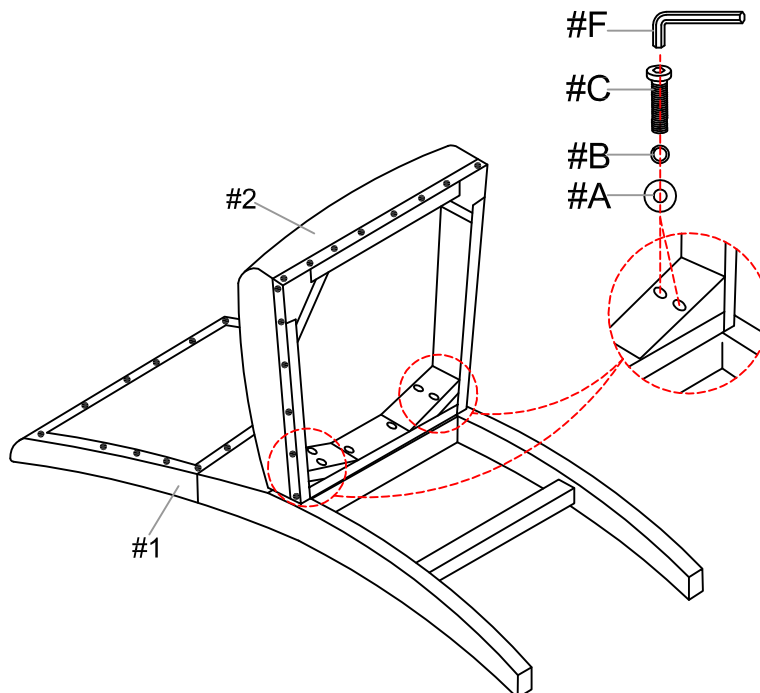

ASSEMBLY INSTRUCTIONS

- I. Insert the front legs (#3) into the front corners of the seat (#2).
- II. Prepare 4 bolt assemblies by FIRST inserting the lock washer (#B) onto the bolt (#E) then the flat washer (#A) onto that SAME bolt (#E). Secure using the Allen wrench (#F).

3

- Part (#3) x 2pcs
- Part (#4) x 2pcs
- Part (#5) x 1pc
- Hardware (#A) x 4pcs
- Hardware (#B) x 4pcs
- Hardware (#E) x 4pcs

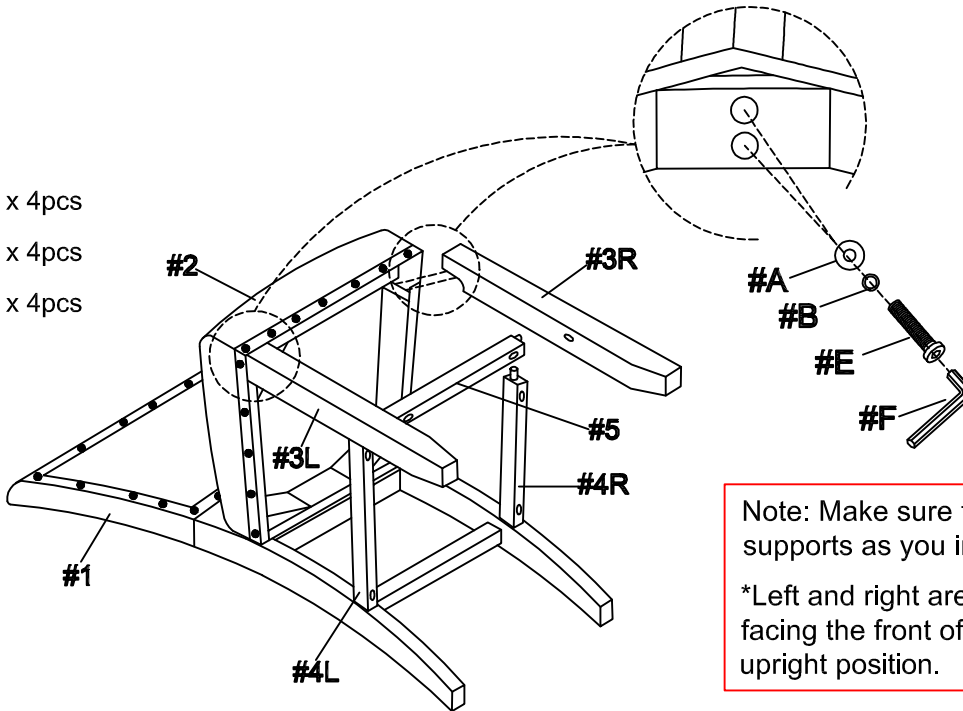

4

- Hardware (#G) x 6pcs

Insert a wood screw (#G) into each pre-drilled hole on the leg supports and secure using the Phillips screwdriver.

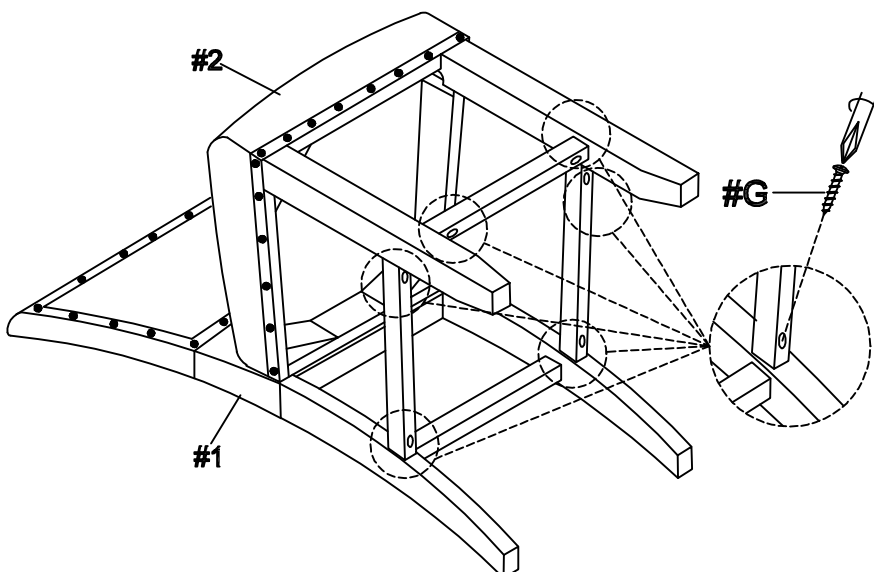

ASSEMBLY COMPLETED



Please ensure the furniture rests on an even and flat surface. If the product wobbles or feels loose, double-check all bolts and/or screws are properly tightened and secured.

✔ Keep this handy!

Please retain this instruction manual and any order-related information for future reference.

✔ Lift, don't drag!

To avoid damage to product please always LIFT the product when transporting or adjusting the placement.