

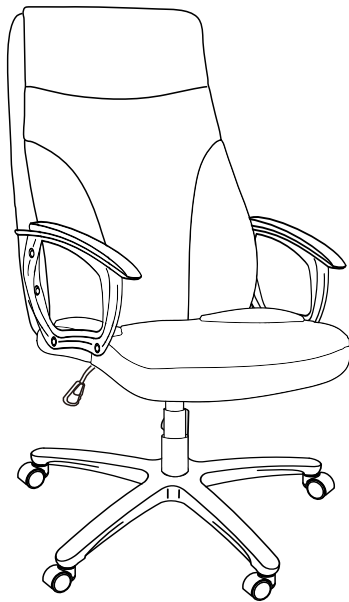

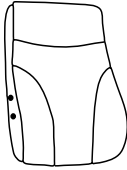





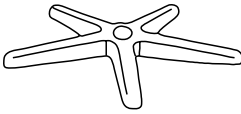
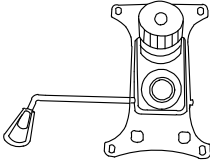

# ASSEMBLY INSTRUCTIONS

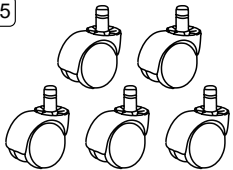

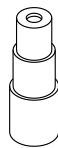
Thank you for purchasing our product!

MAIN PARTS LIST		
<b>A</b> Backrest 	<b>B</b> Seat 	<b>C</b> Nylon star base 
<b>D</b> Mechanism 	<b>E</b> Lift cylinder 	<b>F</b> Casters x5 
<b>G-L</b> Left armrest 	<b>G-R</b> Right armrest 	<b>H</b> Covers for lift cylinder x1 Set 

HARDWARE LIST			
Part #	QTY	SIZE/Description	Item
I	12	M6x20	 mm 10 20 30 40
J	8	Hole covers	

INCLUDED TOOLS	
Allen Wrench	



For international customers & **AK-HI-PR** orders, **the customer is responsible for shipping costs plus any International local taxes or duties.**

## ASSEMBLY STEPS

### STEP 1

1st: Attach F to C using pressure.

2nd: Insert E into C and cover it with H.

F enters into C by pressure

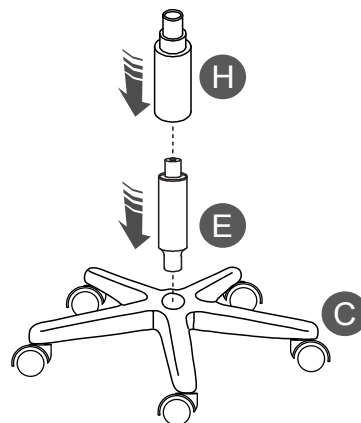
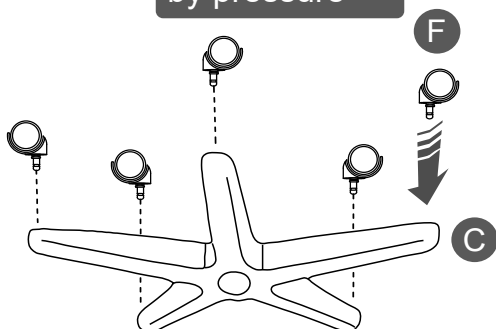

### STEP 2

Use I to attach D to B with its knob towards the front.

⚠ PAY ATTENTION TO THE ORIENTATION!

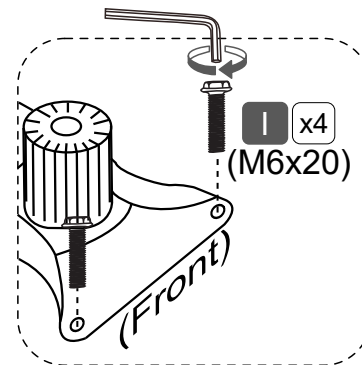
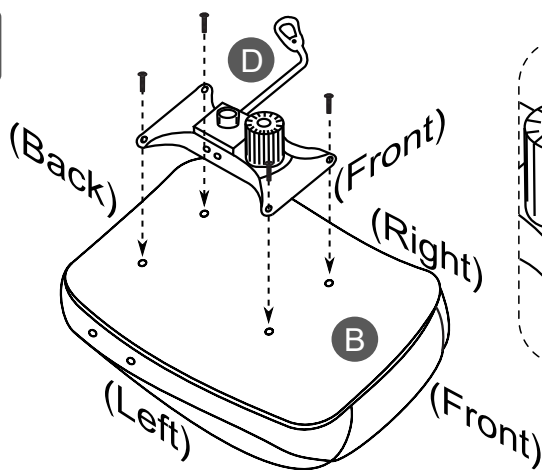
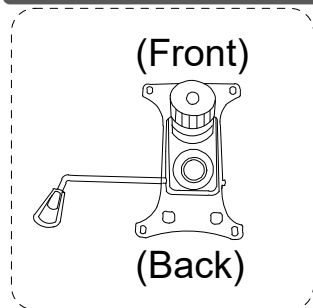

### STEP 3

Join the seat to the base.

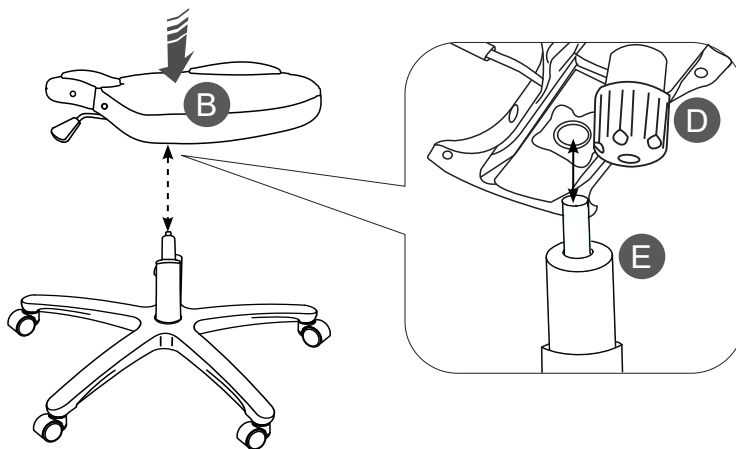

## ASSEMBLY STEPS

### STEP 4

Use I to attach G-L and G-R to B on their respective sides, but **leave them loose**.

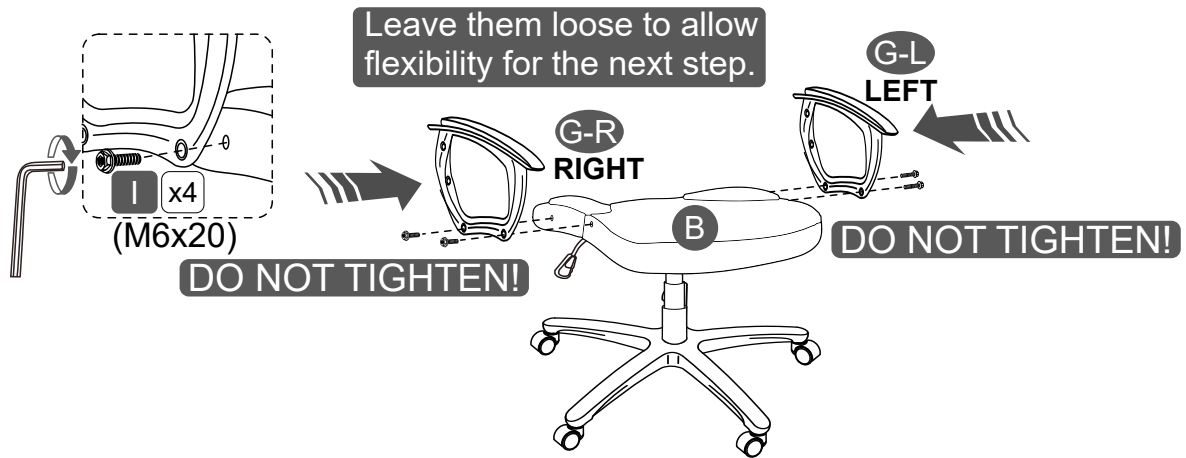

### STEP 5

Use I to attach A to G-L and G-R.

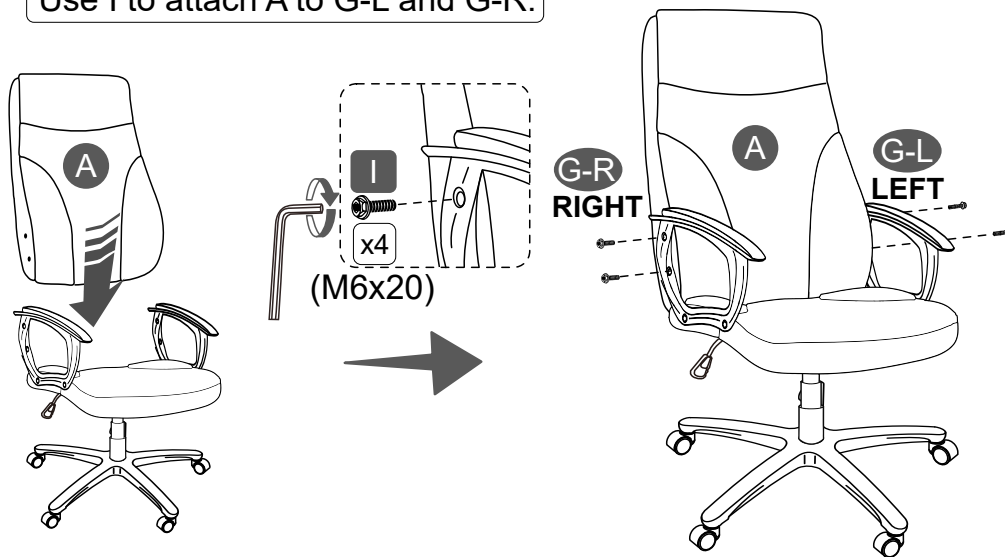

### STEP 6

1st: Proceed to tighten all the screws.

Finally: Cover the holes with J.

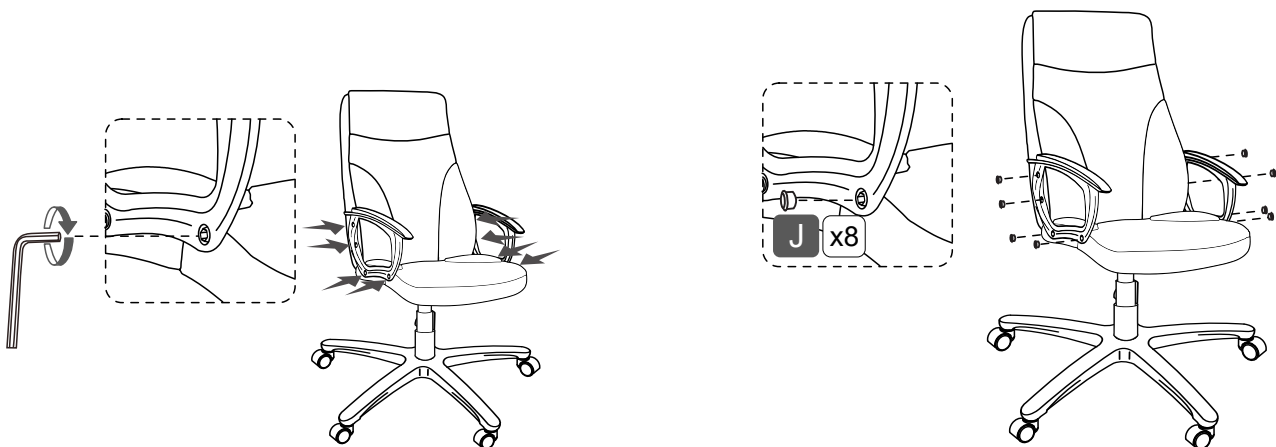

## CHAIR'S FUNCTIONS

Pull Handle UP.

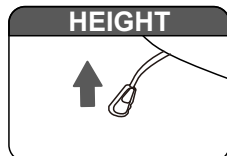

Pull Handle OUT to UNLOCK;  
Push Handle IN to LOCK.

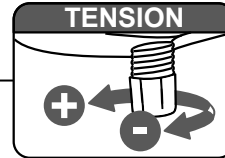
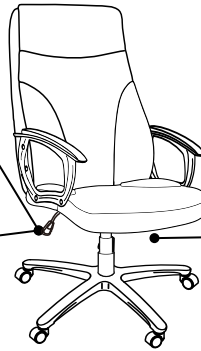
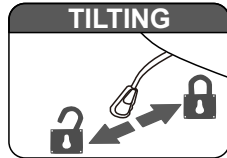

Turn CLOCKWISE for less tension (-);  
COUNTERCLOCKWISE for more tension (+).

With less tension, the tilting feels easier.

## WARNINGS - Not paying attention to the following warnings could result in injuries.

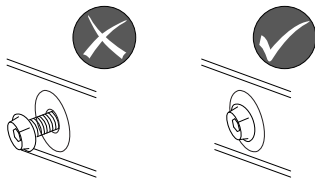

Do not use the chair if the frame parts are damaged, or if any of the screws are loose or missing.

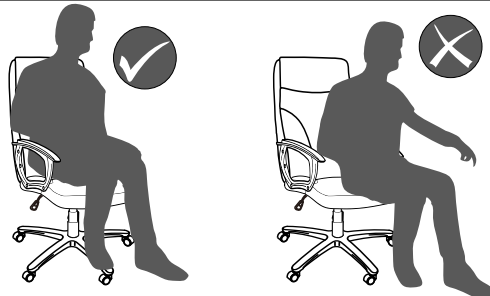

Only one person at a time and refrain from sitting on the edge of the seat to prevent the chair from tipping over.

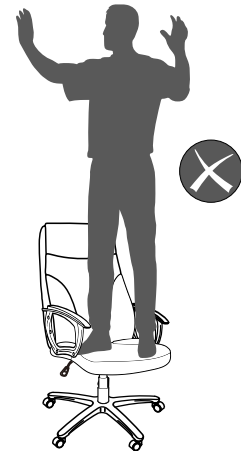

Do not stand or use the chair as ladder.

**WEIGHT LIMIT  
DO NOT EXCEED**

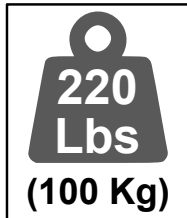

Do not leave babies or toddlers unattended while seated on the chair, always ensure adult supervision. Keep children from playing with the chair for their safety.

## CARE AND MAINTENANCE

Clean with a soft cloth lightly dampened in a solution of smooth soap and water.

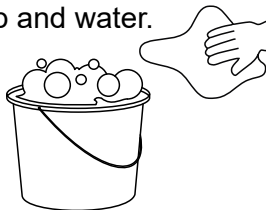

Do not use solvents or abrasive materials.



Do not expose to direct sunlight or to extreme environmental conditions.

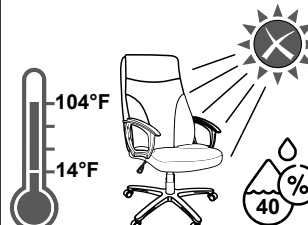

Inspect the chair thoroughly every 4 months and re-tighten the screws.

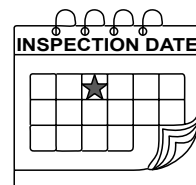

## LIMITED WARRANTY