

Assembly Instructions

ITEM NO. WF 298233
DINING SET

Thank you for purchasing this quality product. Be sure to check all packing materials carefully for small parts, which may have come loose inside the carton during shipment. Identify and count all items and compare with the PARTS LIST and/or HARDWARE LIST shown below.

Caution: Please read the instructions thoroughly before assembly.

1. We recommend that you assemble this product with the assistance of another person; this will make the assembly easier, and will help eliminate damage to the product or injury to persons during assembly.
2. Please do not over tighten screws or bolts until the assembly is completed.
3. Please put all parts on a non-abrasive floor before assembly, and follow the assembly steps to assemble your newly purchased product correctly and efficiently.

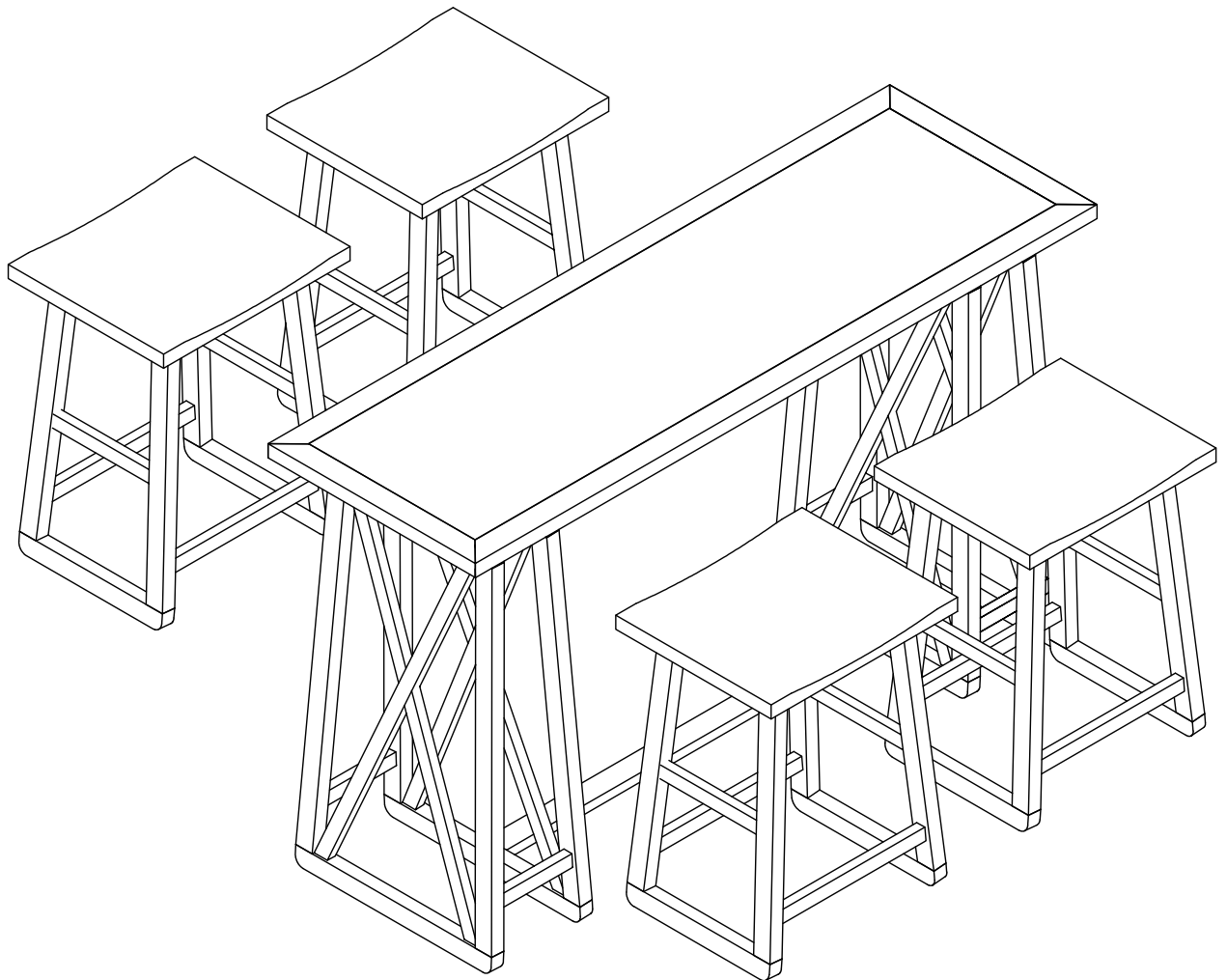







Assembly Instructions

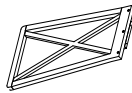
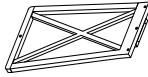
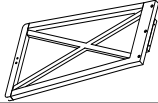
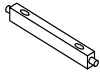

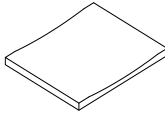

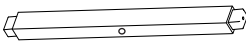
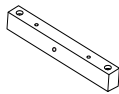
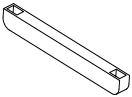

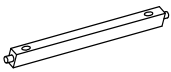
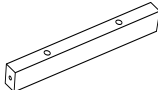
ITEM NO. WF 298233

DINING SET

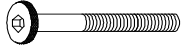
PARTS LIST

NO.	COMPONENT	SKETCH	QTY.
A	Table Top		1PC
B	Side Legs		2PCS
C	Left Leg Inside		1PC
D	Right Leg Inside		1PC
E	Short Stretcher		4PCS
F	Long Stretcher		1PC
G	Seat of Stool		4PCS
H	Legs (Right)		8PCS
I	Legs (Left)		8PCS
J	Upper Stretcher		8PCS
K	Lower Stretcher		8PCS
L	Short Side Stretcher		8PCS
M	Long Side Stretcher		8PCS
N	Support Leg		4PCS

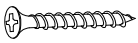
HARDWARE LIST

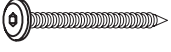
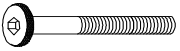
NO.	COMPONENT	SKETCH	QTY.
1	Bolt 1/4 * 1 3/4"		14PCS
2	Flat Washer 1/4" DIA		38PCS
3	Spring Washer 1/4" DIA		38PCS
4	ALLEN KEY M4		1PC
5	WOOD SCREW #8 * 1 2/5"L		48PCS
6	WOODEN DOWEL #10 * 30		18PCS
7	Bolt Wooden 1/4 * 2 1/5"		40PCS
8	Bolt 1/4 * 2"		24PCS

Assembly Instructions

ITEM NO. WF 298233
DINING SET

ASSEMBLY TOOLS REQUIRED (NOT INCLUDED)

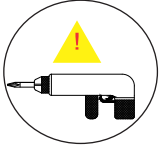

PLEASE BE CAREFUL DO NOT DAMAGE THE HOLE POSITION WHEN YOU USE POWERTOOLS!

STEP 1

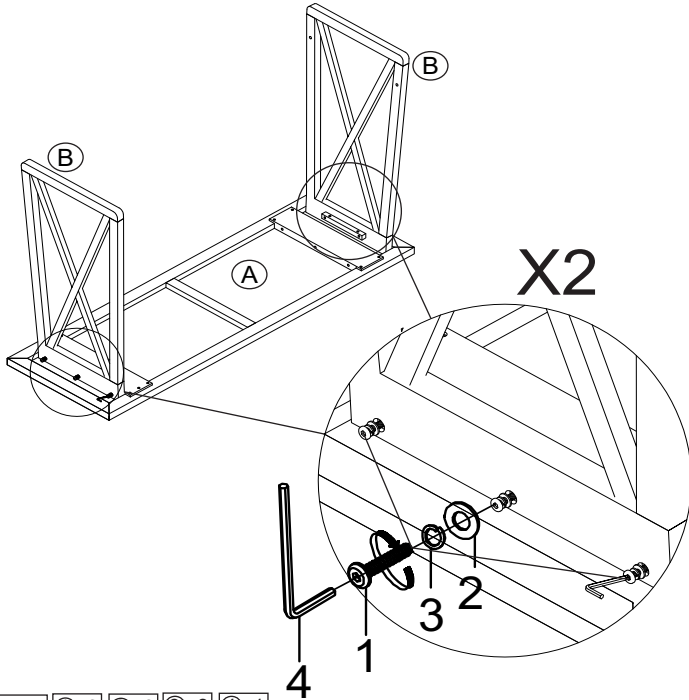

A x1 Bx2 ①x6 ②x6 ③x6 ④x1

STEP 2

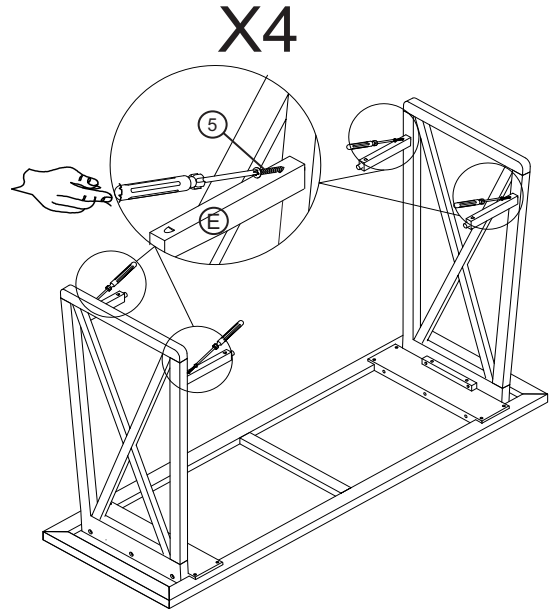

E x4 ⑤x4

STEP 3

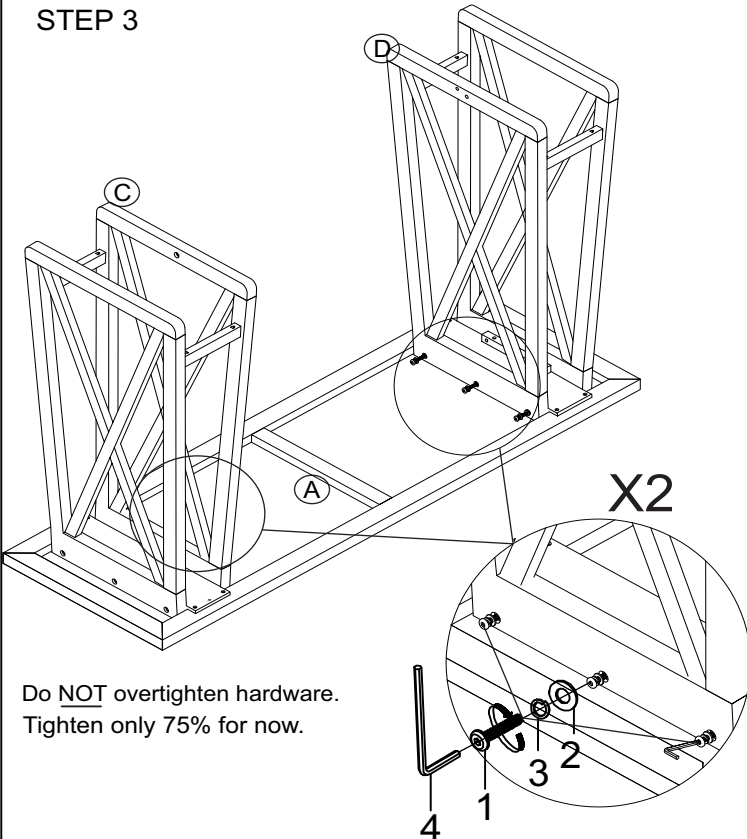

Do **NOT** overtighten hardware.
Tighten only 75% for now.

C x1 D x1 ①x6 ②x6 ③x6 ④x1

STEP 4

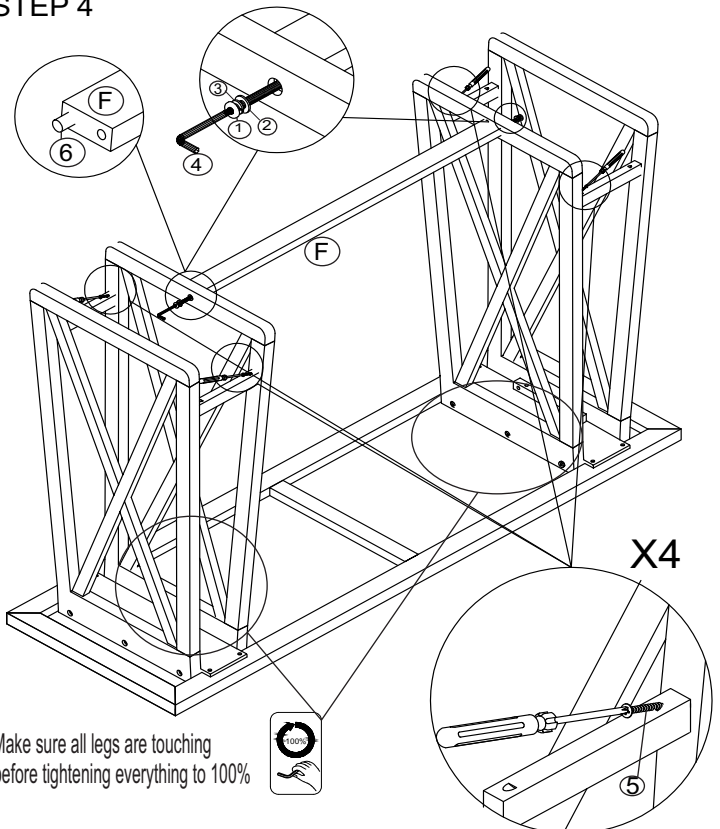

Make sure all legs are touching
before tightening everything to 100%



F x1 ①x2 ②x2 ③x2 ④x1 ⑤x4 ⑥x2

MADE IN VIETNAM

PAGE: 4 OF 6

Assembly Instructions

ITEM NO. WF 298233
DINING SET



ASSEMBLY TOOLS REQUIRED (NOT INCLUDED)



PLEASE BE CAREFUL DO NOT DAMAGE THE HOLE POSITION WHEN YOU USE POWERTOOLS!

STEP 5

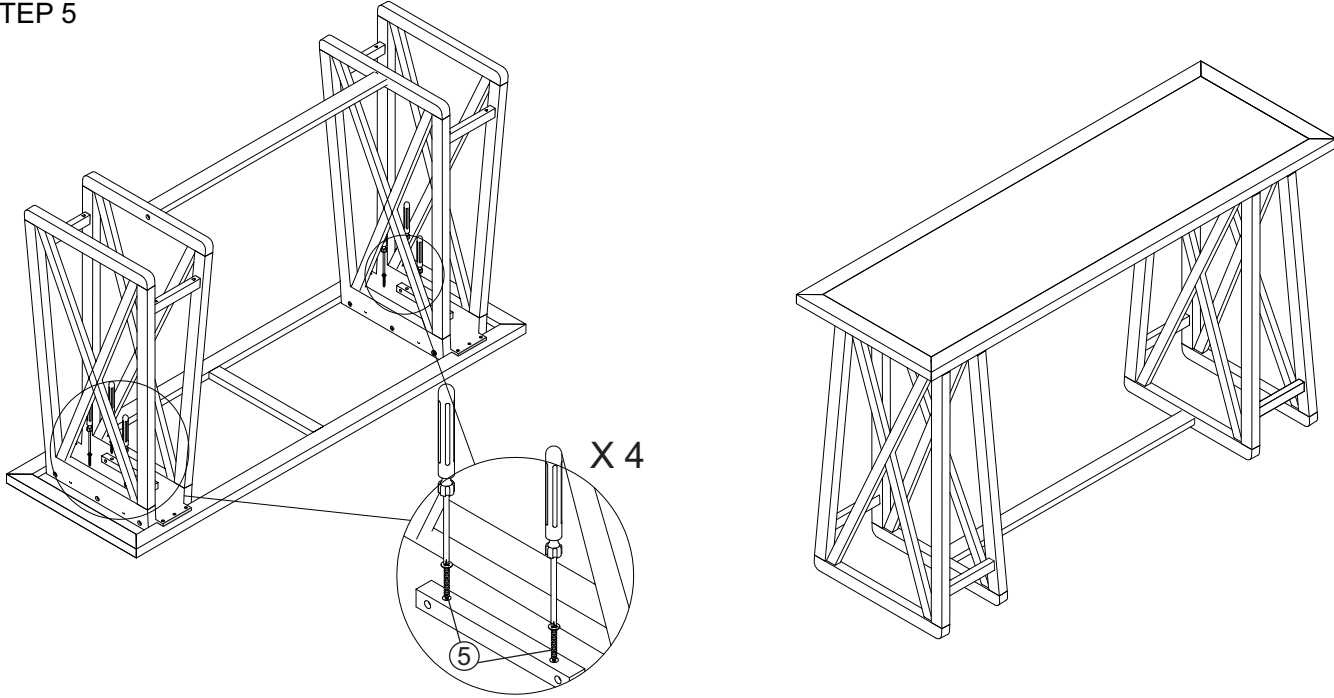

⑤ x8

STEP 6

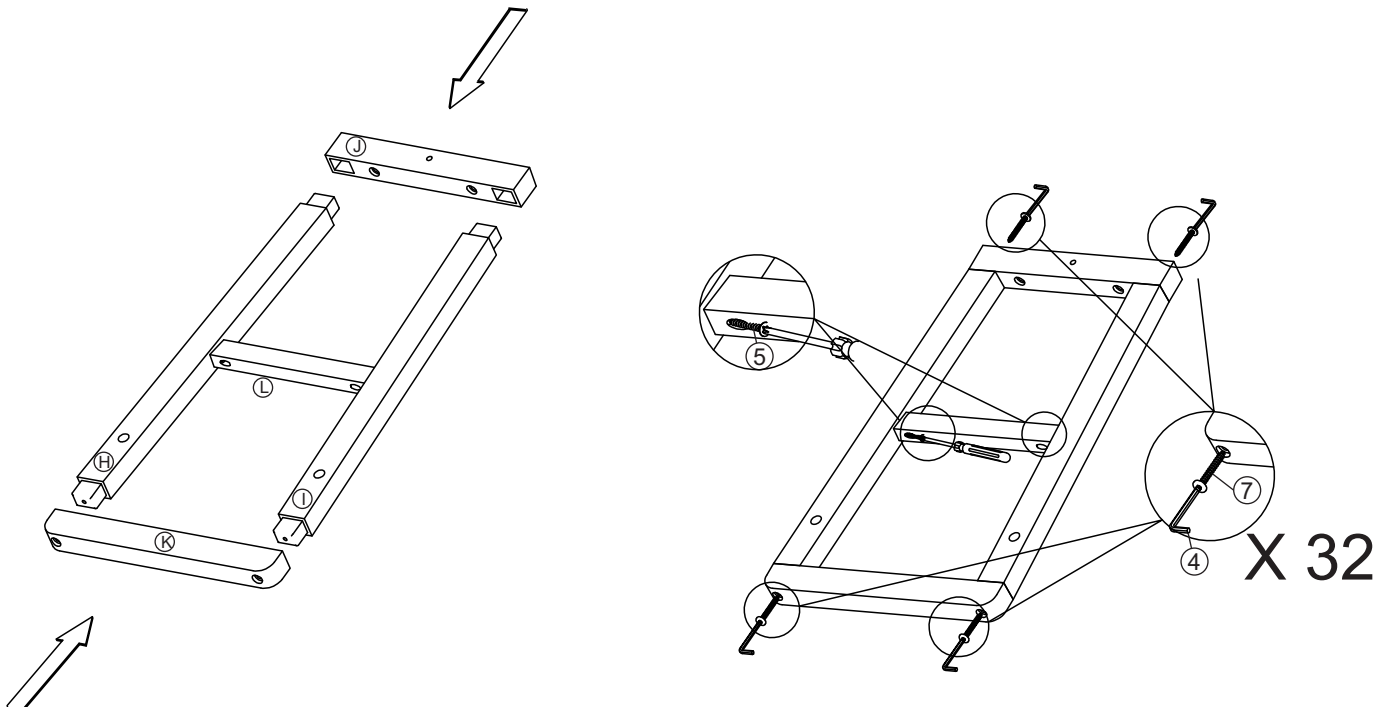

H x8 | I x 8 | J x8 | K x 8 | L x8 | ④ x1 | ⑤ x16 | ⑦ x32

MADE IN VIETNAM

PAGE: 5 OF 6

Assembly Instructions

ITEM NO. WF 298233
DINING SET



ASSEMBLY TOOLS REQUIRED (NOT INCLUDED)



PLEASE BE CAREFUL DO NOT DAMAGE THE HOLE POSITION WHEN YOU USE POWERTOOLS!

STEP 7

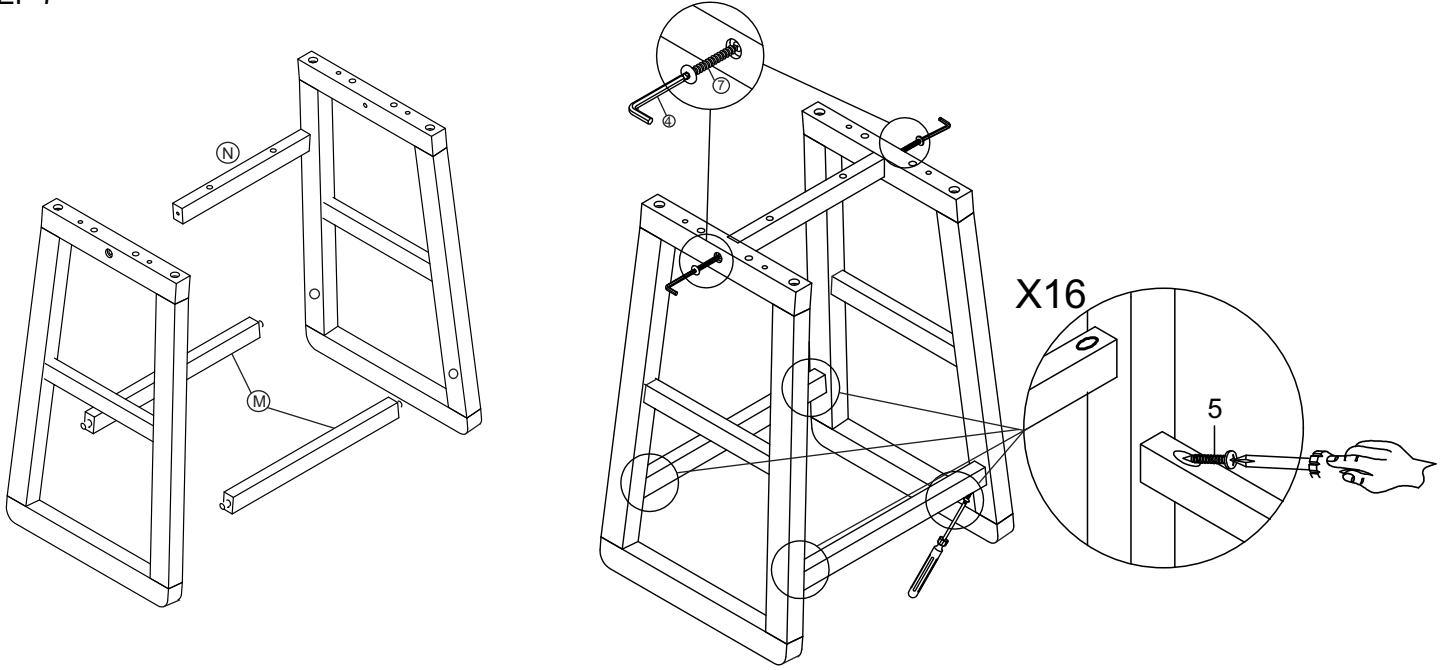

N x4 M x 8 4 x1 5 x16 7 x8

STEP 8

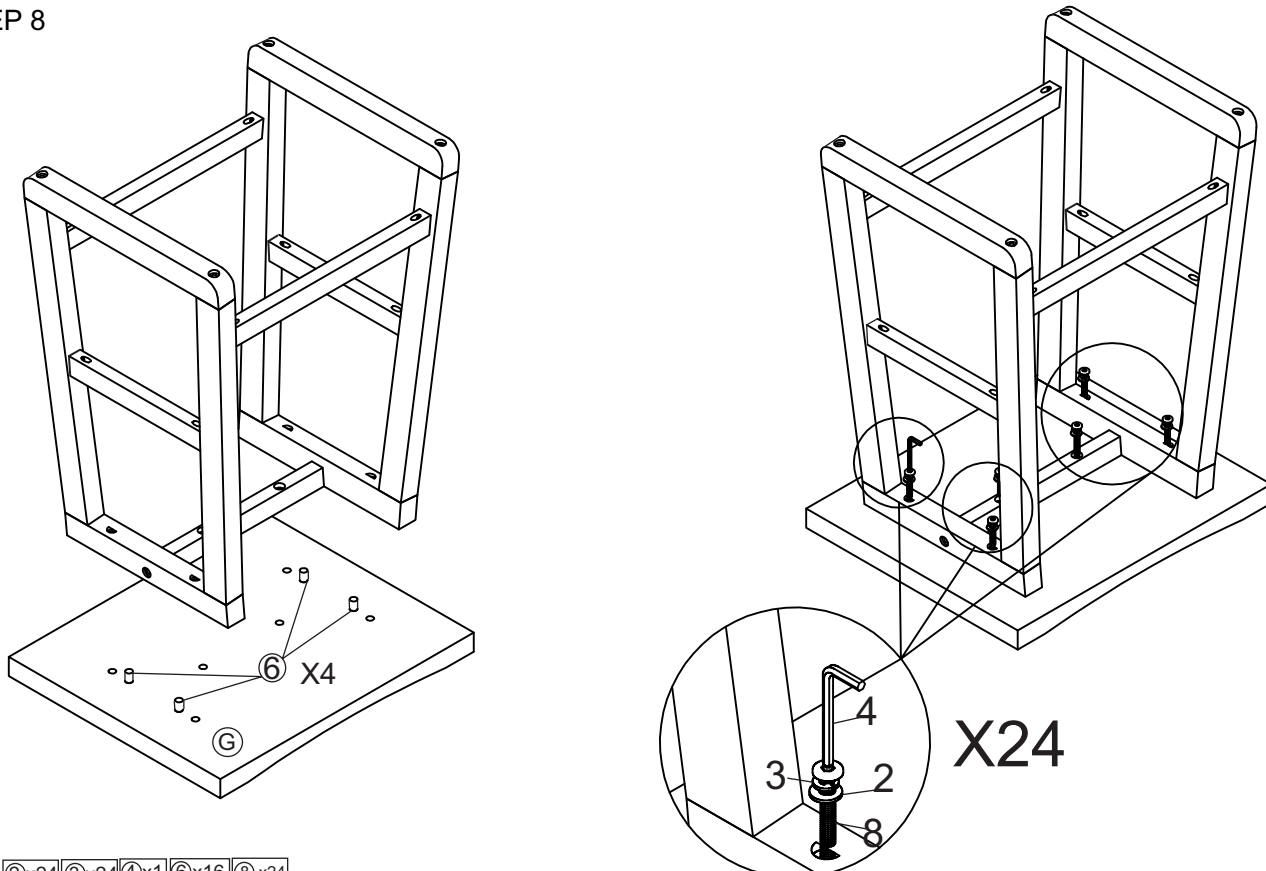

G x4 2 x24 3 x24 4 x1 6 x16 8 x24