

LDTV06

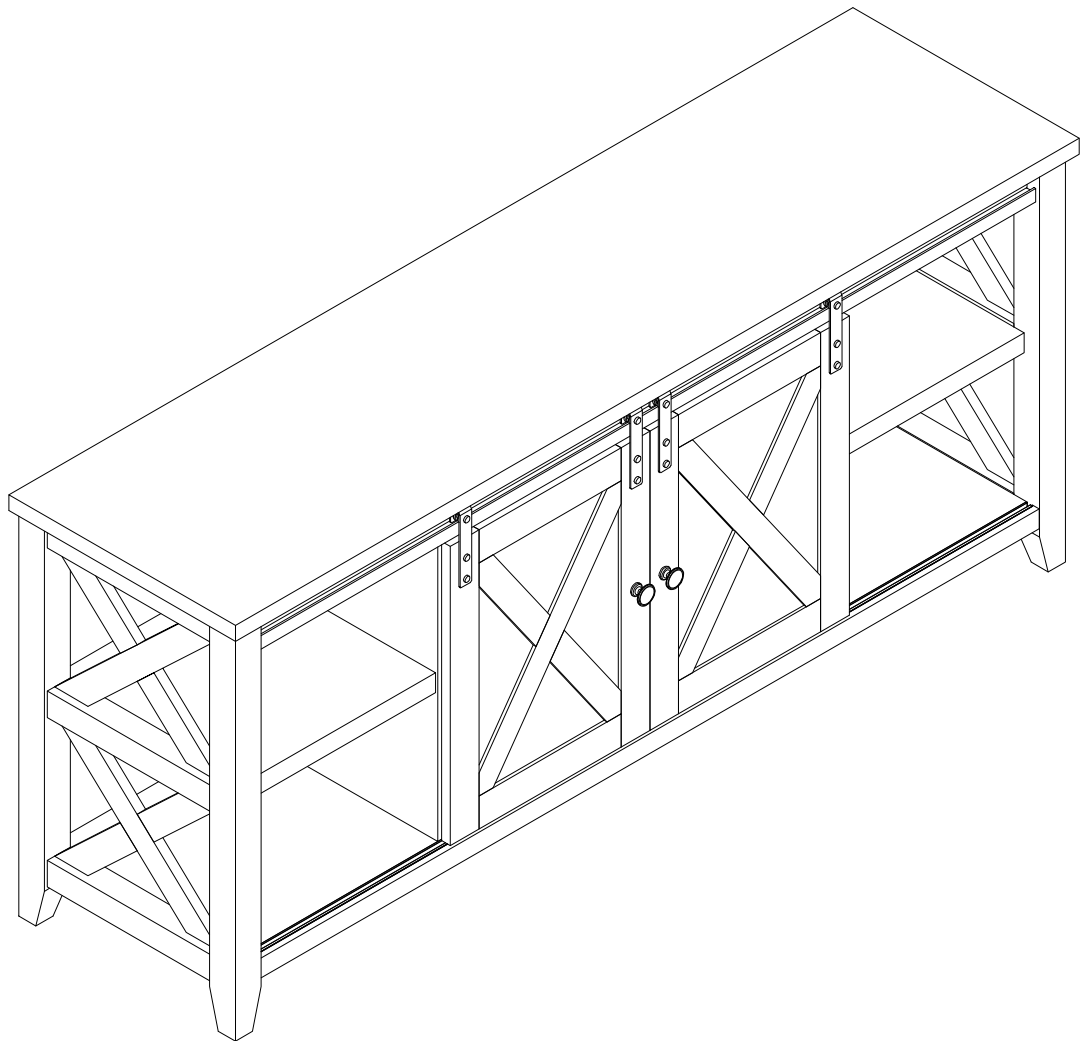

Thank you for purchase on our products. Please contact us if you have difficulty with assembly or need replacement parts.

Please login your amazon account > choose Your orders>Find the order ID > click Contact seller, we will provide you with the most satisfactory service!

IMPORTANT SAFETY INFORMATION



WARNING

DEATH OR SERIOUS INJURY MAY OCCUR WHEN CHILDREN CLIMB ON AUDIO AND/OR VIDEO EQUIPMENT FURNITURE. A REMOTE CONTROL OR TOYS PLACED ON THE FURNISHING MAY ENCOURAGE A CHILD TO CLIMB ON THE FURNISHING AND AS A RESULT THE FURNISHING MAY TIP OVER ON TO THE CHILD.

MUERTE O LESIONES GRAVES PUEDEN OCURRIR CUANDO LOS NIÑOS SUBAN AL AUDIO Y / O MOBILIARIO EQUIPO DE VÍDEO. UN MANDO A DISTANCIA O LOS JUGUETES EXISTENTES EN EL MOBILIARIO PUEDE ANIMAR AL NIÑO A SUBIR A LOS MUEBLES Y COMO RESULTADO EL MOBILIARIO PUEDEN VOLCARSE A LA NIÑO(A).

MORT OU DES BLESSURES GRAVES PEUVENT SE PRODUIRE LORSQUE LES ENFANTS MONTER SUR L'AUDIO ET / OU DES MEUBLES DE L'ÉQUIPEMENT VIDÉO. UNE TÉLÉCOMMANDE OU LES JOUETS MIS SUR L'AMEUBLEMENT PEUVENT ENCOURAGER UN ENFANT À GRIMPER SUR LA FOURNITURE ET COMME RÉSULTAT L'AMEUBLEMENT PEUVENT BASCULER À L'ENFANT.



WARNING

RELOCATING AUDIO AND/OR VIDEO EQUIPMENT TO FURNITURE NOT SPECIFICALLY DESIGNED TO SUPPORT AUDIO AND/OR VIDEO EQUIPMENT MAY RESULT IN DEATH OR SERIOUS INJURY DUE TO THE FURNISHING COLLAPSING OR OVER TURNING ONTO A CHILD.

REUBICACIÓN DE AUDIO Y / O EQUIPO DE VÍDEO A LOS MUEBLES NO ESTÁN DISEÑADOS ESPECÍFICAMENTE PARA APOYAR EL EQUIPO DE AUDIO Y / O VÍDEO PUEDE CAUSAR LA MUERTE O LESIONES GRAVES DEBIDO A LA DECORACIÓN COLAPSE O MÁS DE INFLEXIÓN EN UN NIÑO.

DÉPLACEMENT AUDIO ET / OU VIDÉO À DES MEUBLES PAS SPÉCIFIQUEMENT DESTINÉ À SOUTENIR L'ÉQUIPEMENT AUDIO ET / OU VIDÉO PEUT ENTRAINER LA MORT OU DES BLESSURES GRAVES EN RAISON DE LA FOURNITURE DE S'EFFONDRE OU PLUS EN TOURNANT SUR UN ENFANT.

Thank you for your purchase!

Please carefully understand the following before assembling the product:

- 1.Lack of instruction manual
- 2.Lack of accessories
- 3.Defective products
- 4.Inappropriate size
- 5.Other problems

As long as you encounter any of the above situations, you can contact us through the following after-sales service email.

Our after-sales customer service team will definitely help you solve any problems within 24 hours

After sales service email:

customerservice-vip2@outlook.com

Please remember!

Don't worry if you encounter any problems, just contact us and we will solve them for you!

USE AND CARE

1. To clean, use a soft cloth slightly dampened with water.
 2. Do not use abrasive cleaners or spray liquids.
 3. Using solvents of any kind on your furniture may damage your furniture's finish.
 4. Liquid spills should be removed immediately. Using a soft clean cloth, blot the spill gently. Avoid rubbing.
 5. Stains or marks from crayons or ink markers will be difficult to remove.
 6. Do not climb or step on the stand.
 7. Periodically check that all fasteners are tightened.
-







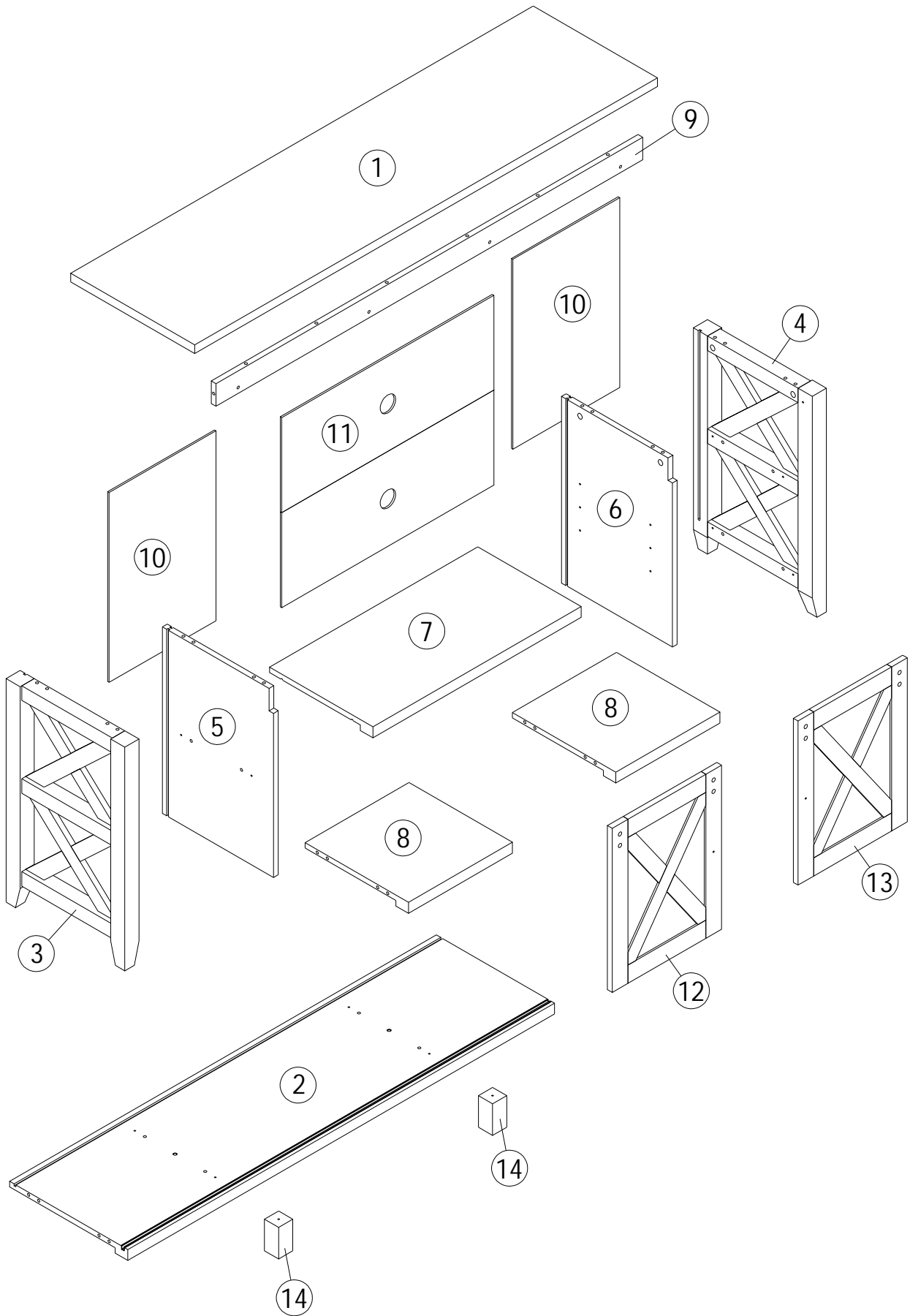

1. Para limpiar, use un paño suave ligeramente humedecido con agua.
 2. No use limpiadores abrasivos o rociadores.
 3. El uso de disolventes de ningún tipo sobre sus muebles pueden dañar el acabado de sus muebles.
 4. Los derrames de líquidos deben ser retirados inmediatamente. Con un paño suave y limpio, seque el derrame suavemente. Evite frotar.
 5. Las manchas o marcas de crayones o marcadores de tinta serán difíciles de eliminar.
 6. No se suba o pisar el stand.
 7. Compruebe periódicamente que todos los sujetadores estén apretados.
-

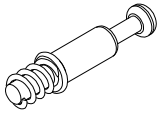
1. Pour nettoyer, utilisez un chiffon doux légèrement humidifié avec de l'eau.
2. Ne pas utiliser de nettoyeurs abrasifs ou de liquides en aérosol.
3. L'utilisation de solvants d'aucune sorte sur vos meubles peut endommager le fini de votre mobilier.
4. Les déversements de liquides doivent être retirés immédiatement. L'utilisation d'un chiffon propre et doux, éponger délicatement le déversement. Évitez de frotter.
5. Taches ou les marques de crayons ou des marqueurs d'encre sera difficile à enlever.
6. Ne pas monter ou marcher sur le stand.
7. Vérifier périodiquement que toutes les fixations sont serrées..

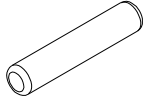
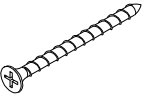
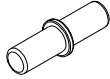
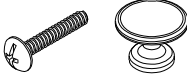
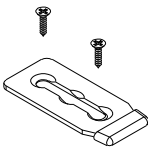
CONTENTS

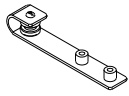

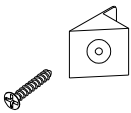
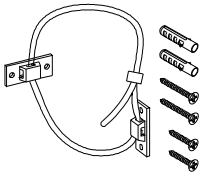
HARDWARE

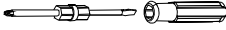
<p>A x26</p> 	<p>B x26</p> 	<p>C x26</p>  <p>M8*30</p>
<p>D x4</p>  <p>M4*50mm</p>	<p>E x4</p> 	<p>F x2</p> 
<p>G x2</p> 	<p>H x8</p>  <p>G1/4"*12mm</p>	<p>I x4</p>  <p>G1/4"*20mm</p>
<p>J x4</p> 	<p>K x8</p> 	<p>L x1</p>  <p>1356mm</p>
<p>M x12</p> 	<p>N x2</p> 	<p>O x2</p>  <p>M6.3*40mm</p>
		

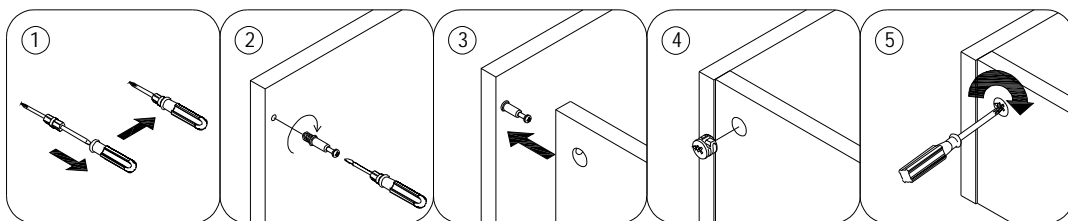

Assembly Steps

Step 1

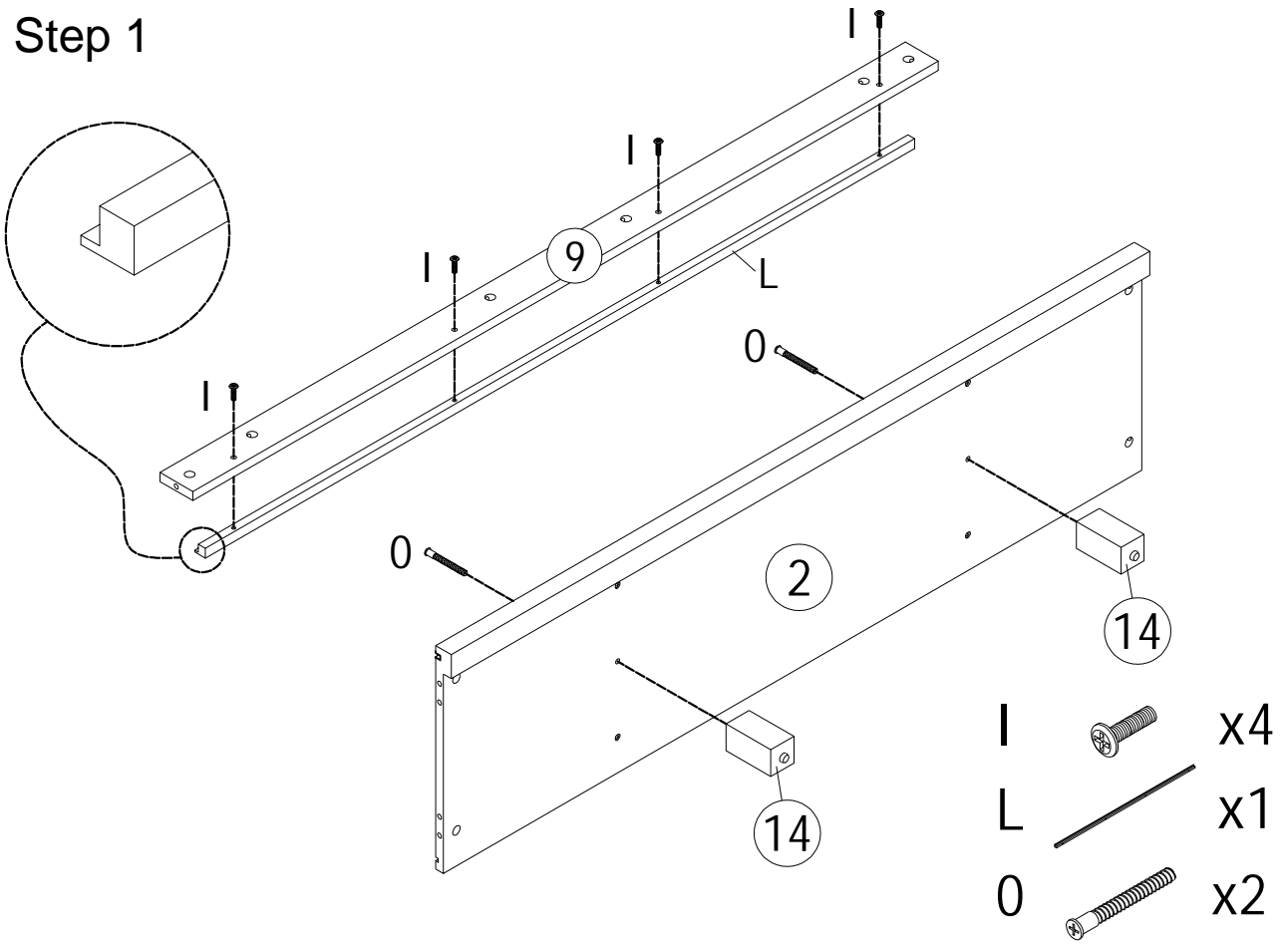

Step 2

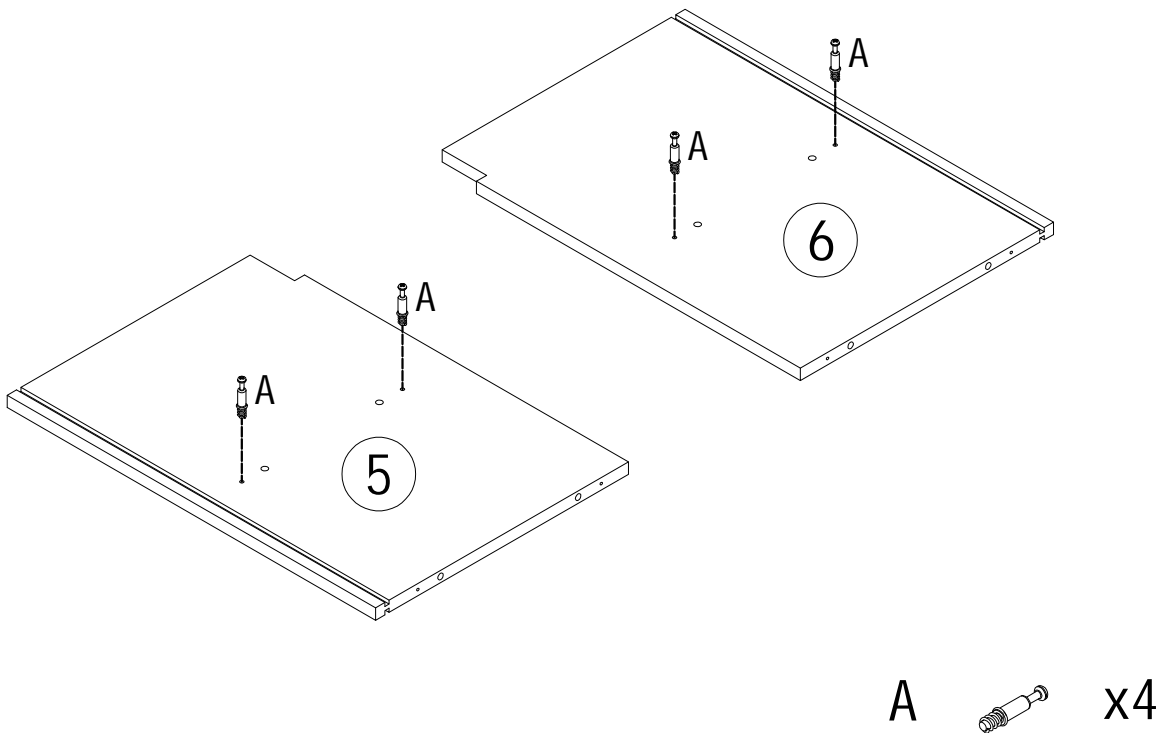

Assembly Steps

Step 3

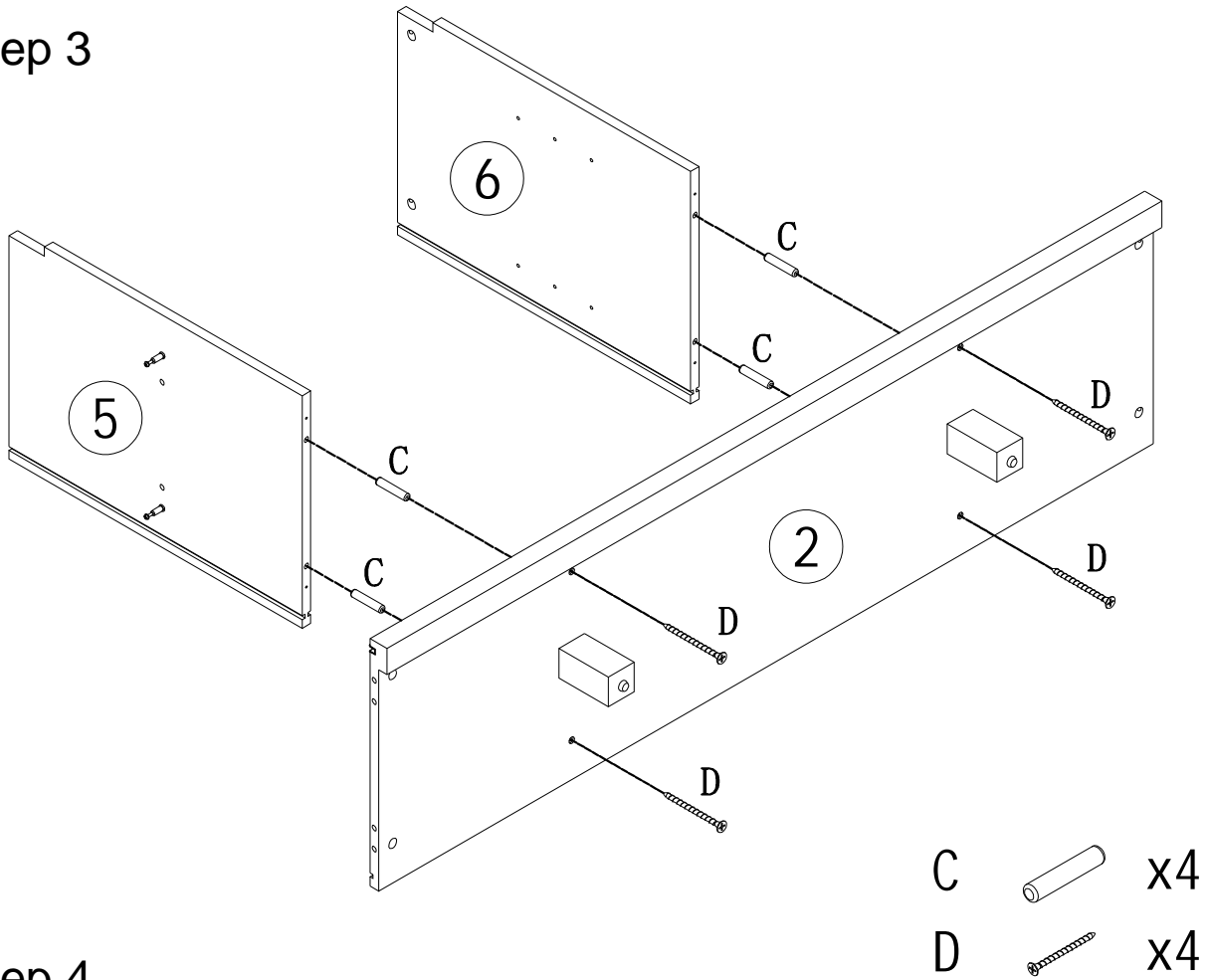

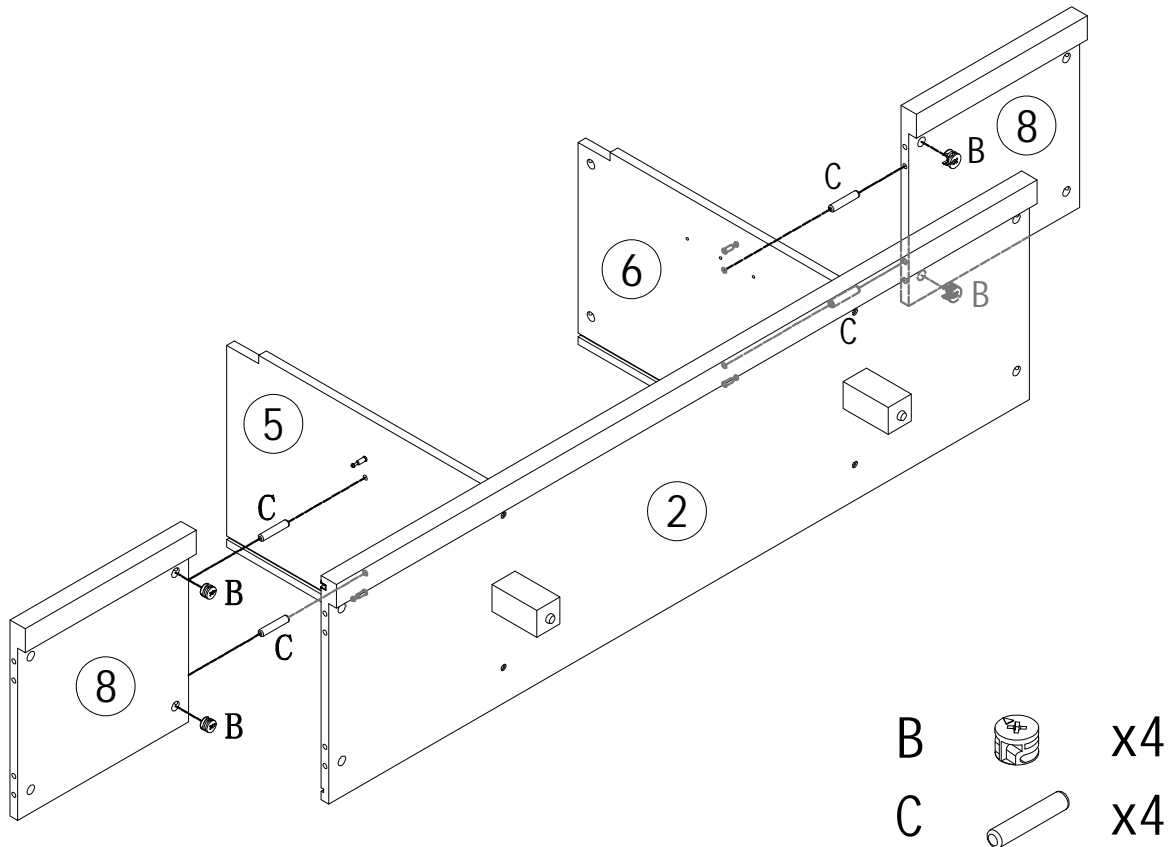

Step 4

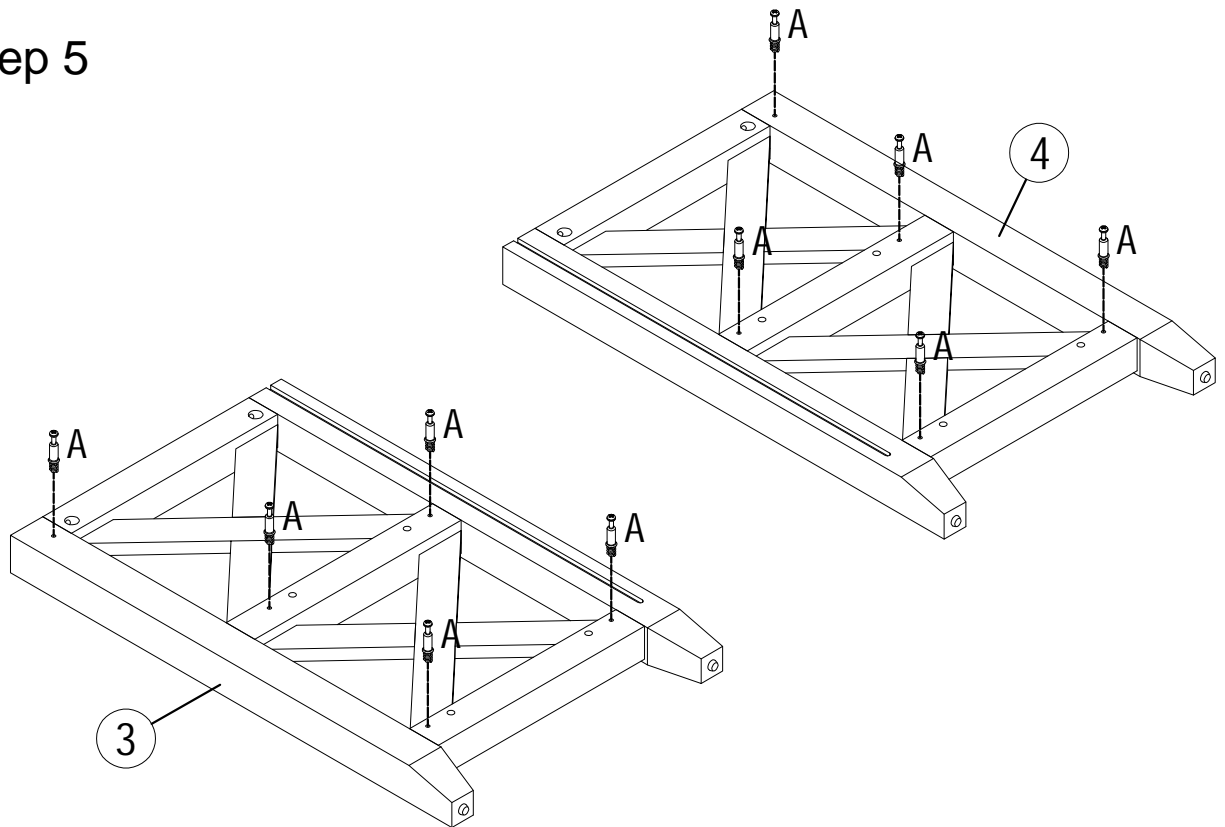

Assembly Steps

Step 5



A  x10

Step 6

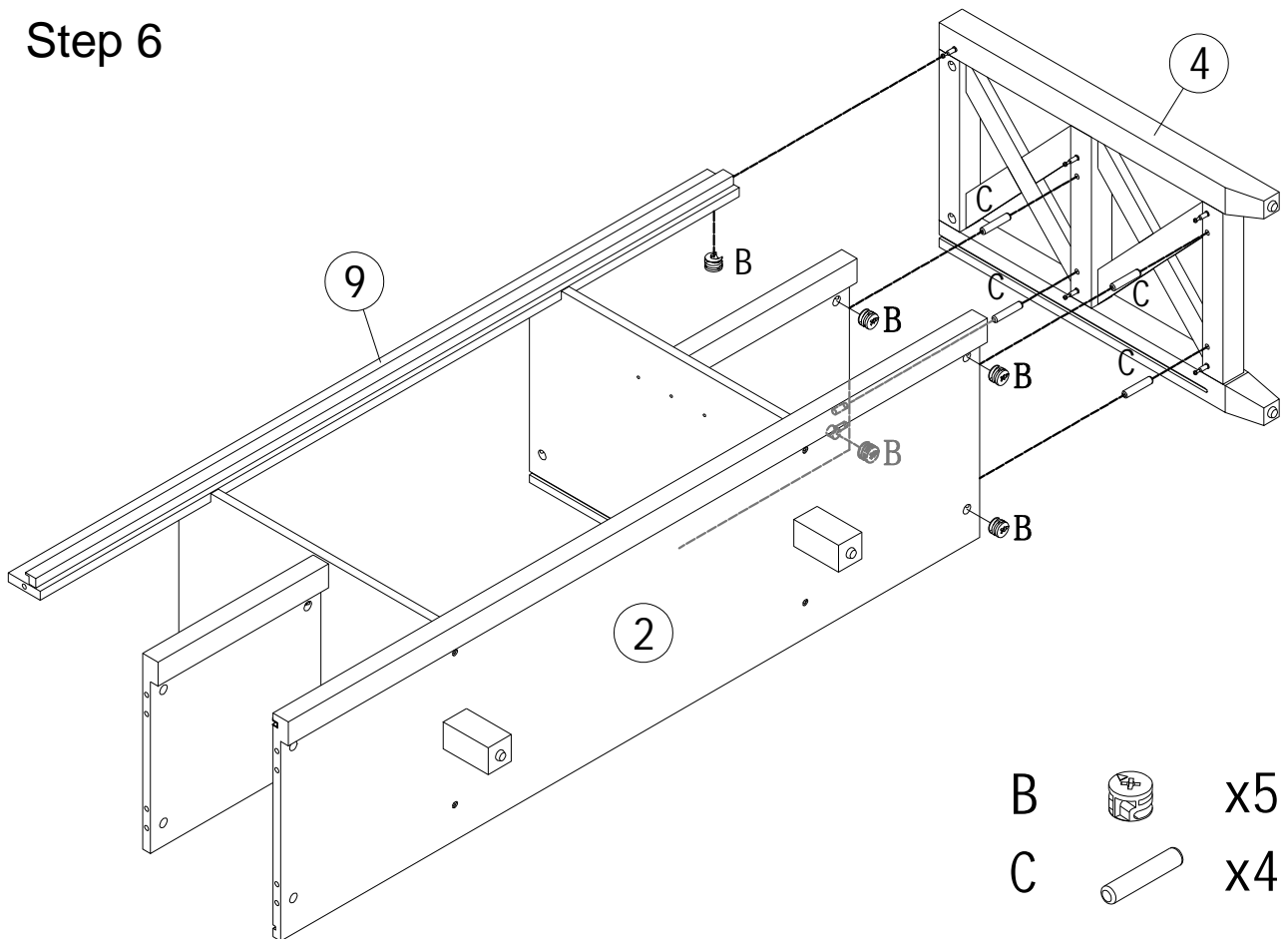



B  x5

C  x4

Assembly Steps

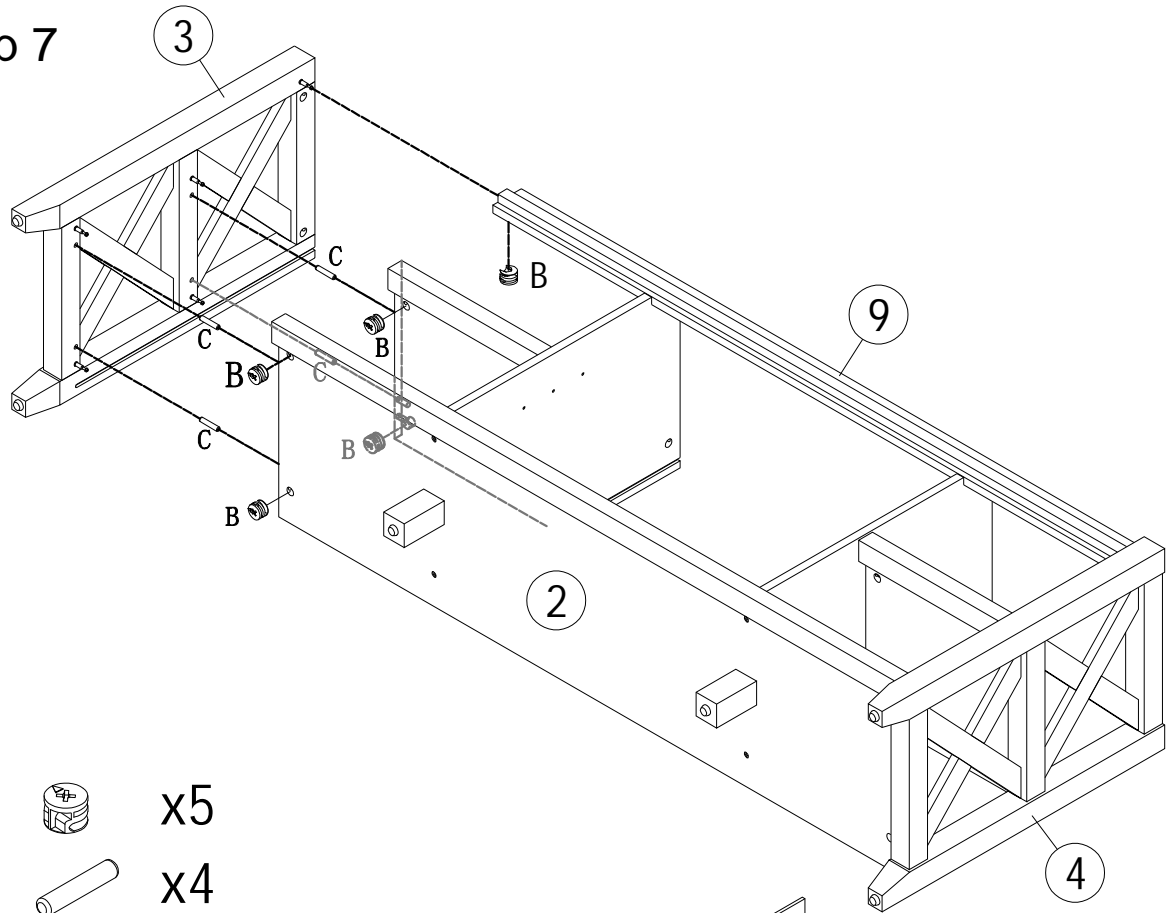
Step 7



- B  x5
- C  x4

Step 8

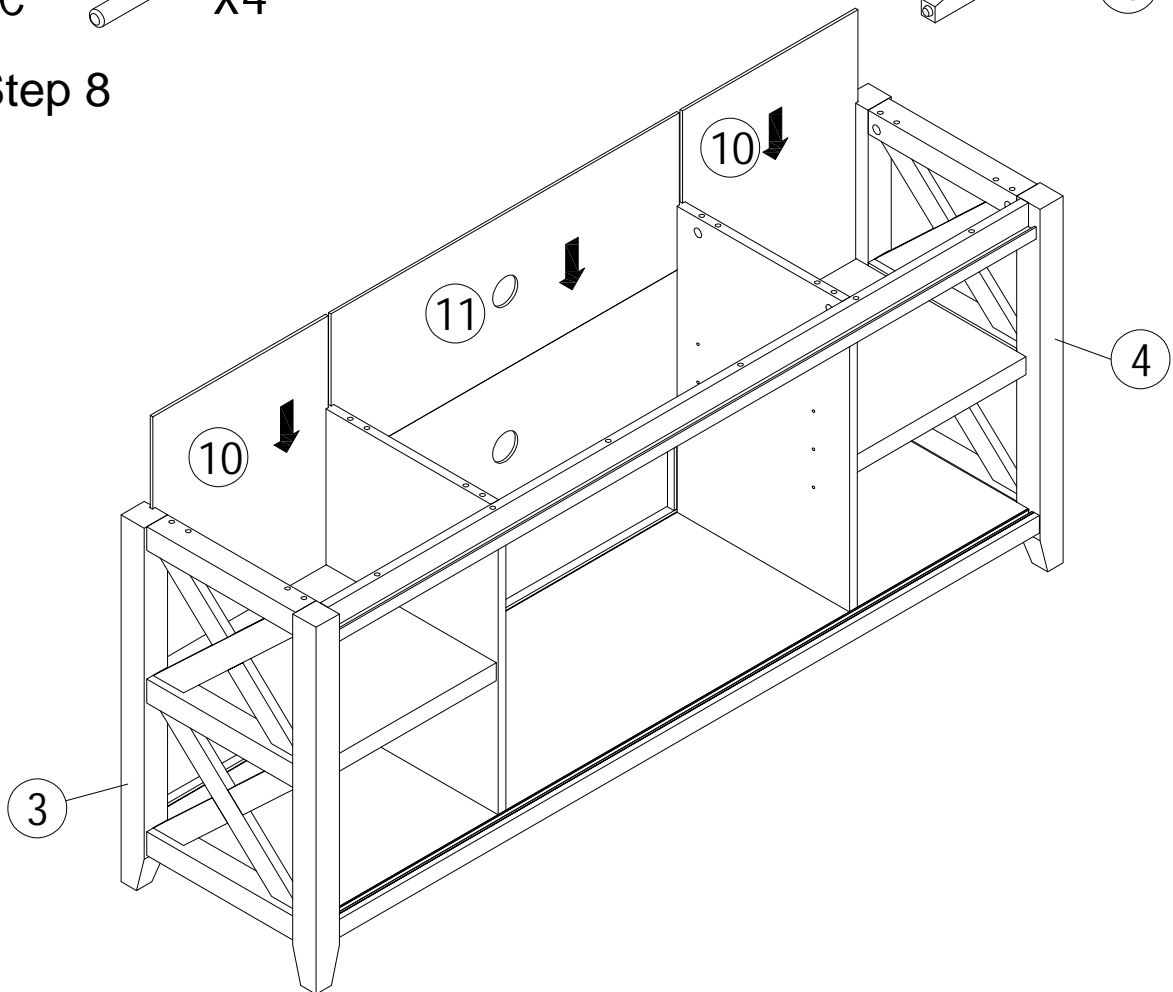

Assembly Steps

Step 9

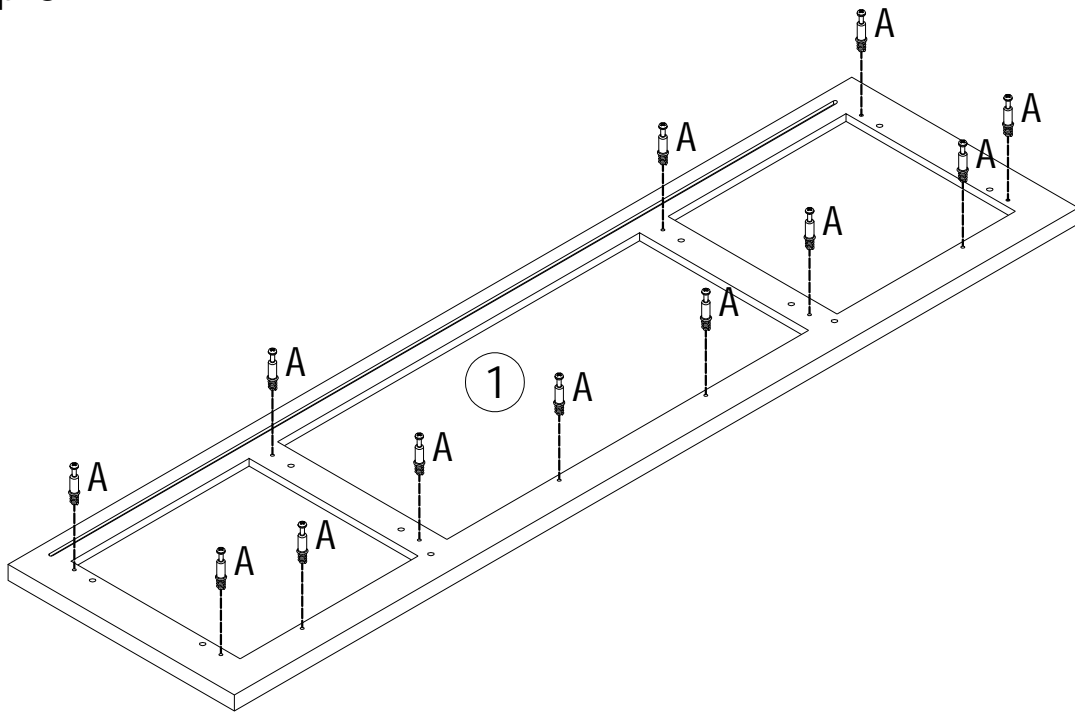

Step 10

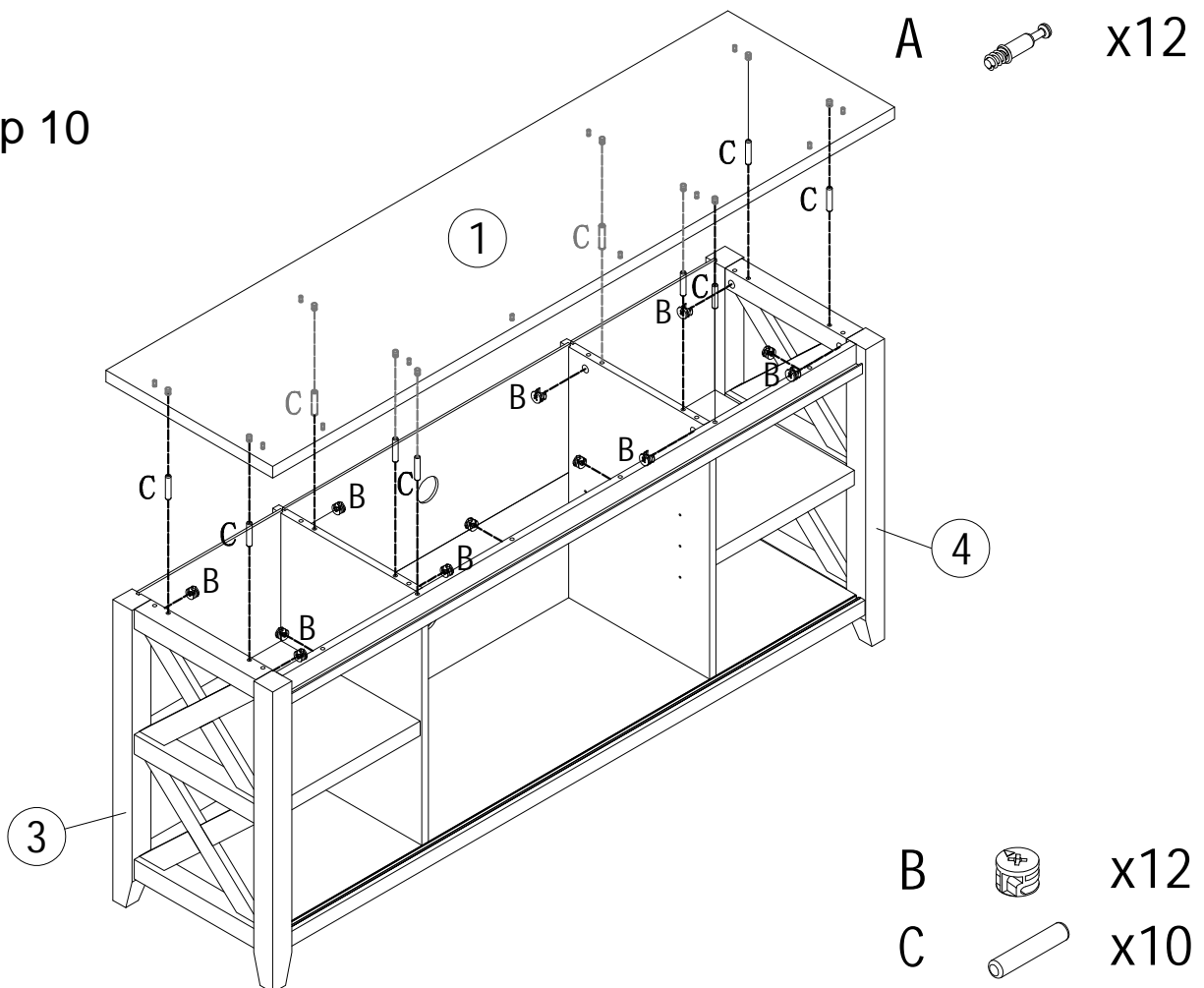

Assembly Steps

Step 11

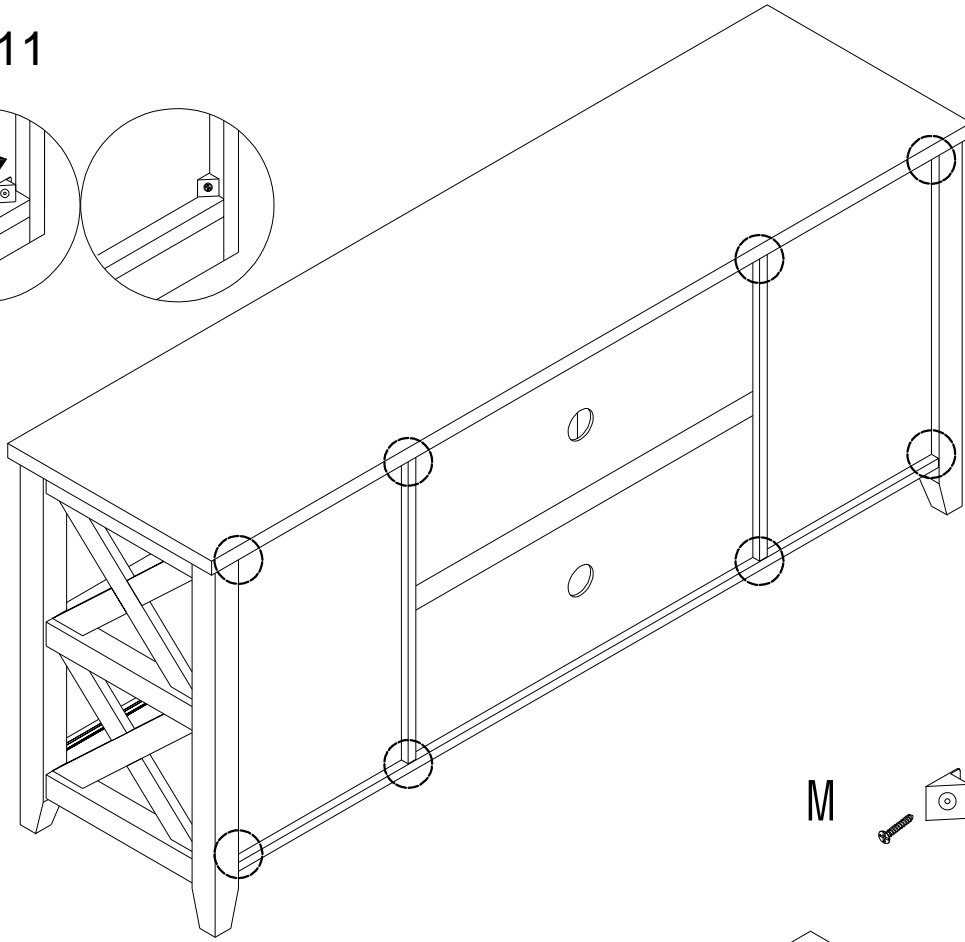
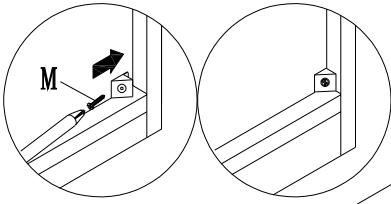

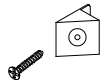
M  x12

Step 12

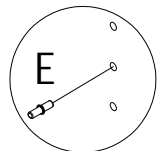
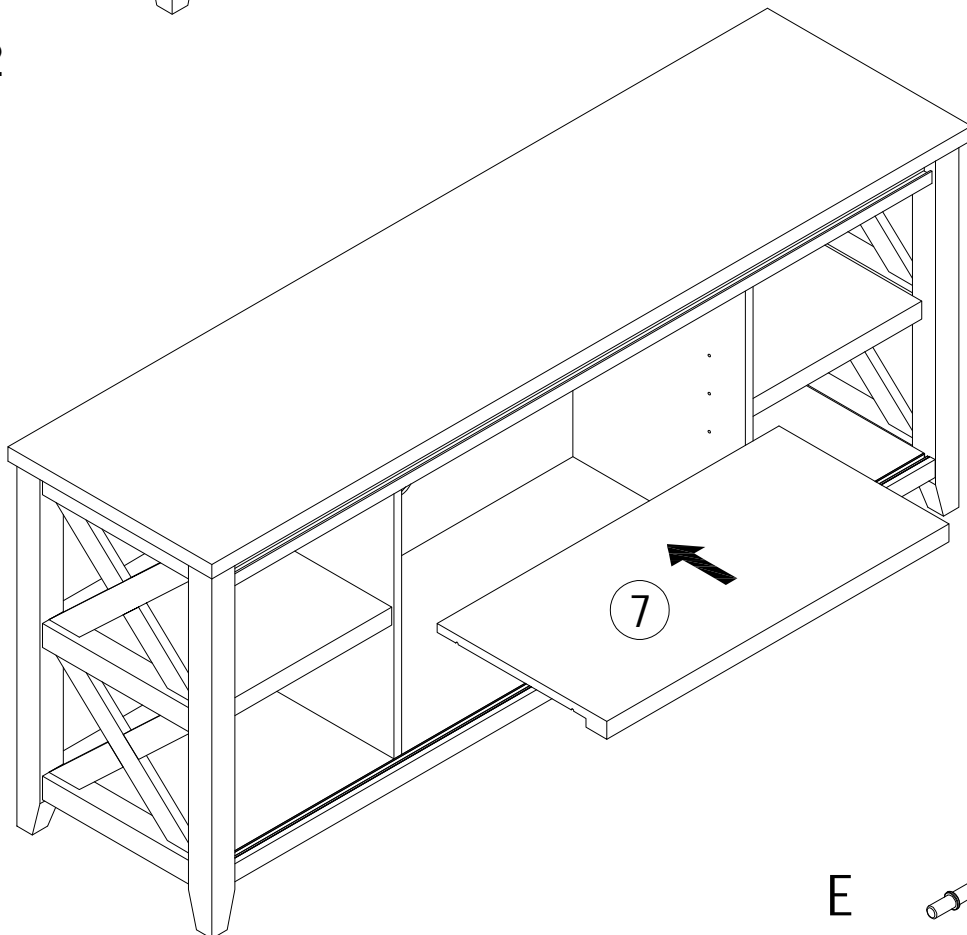



E  x4

Assembly Steps

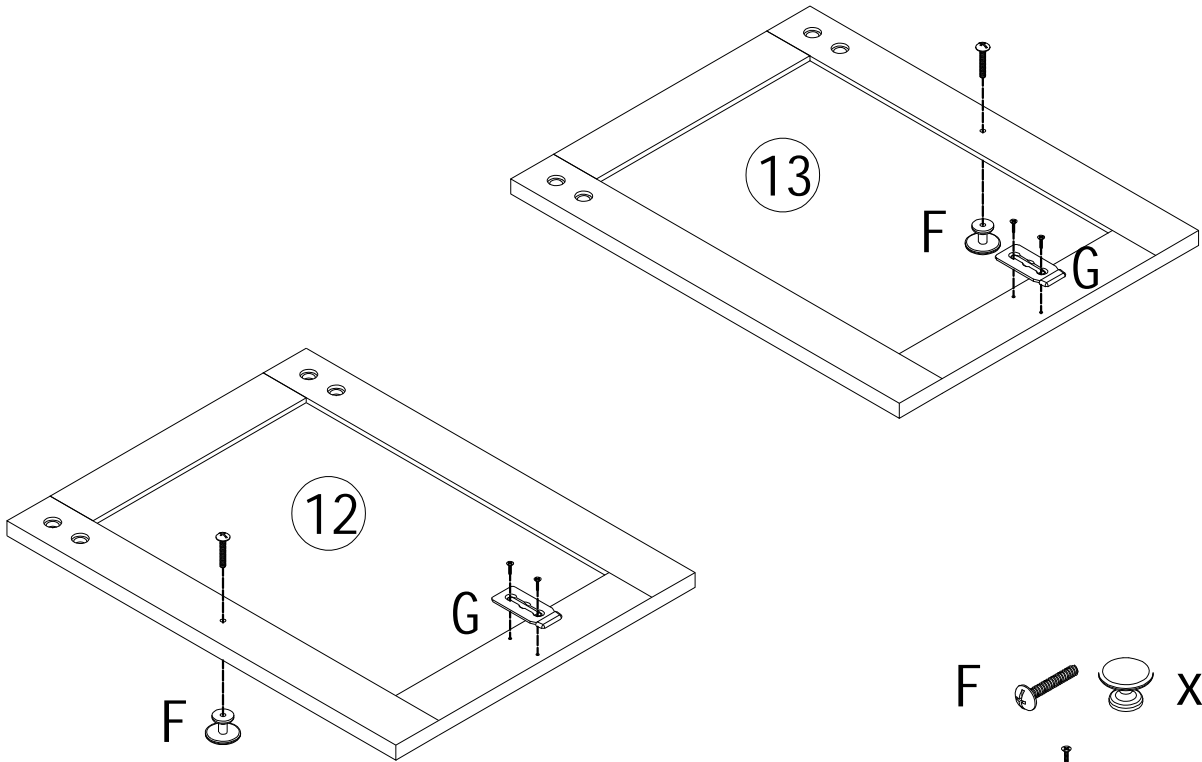

Step 13

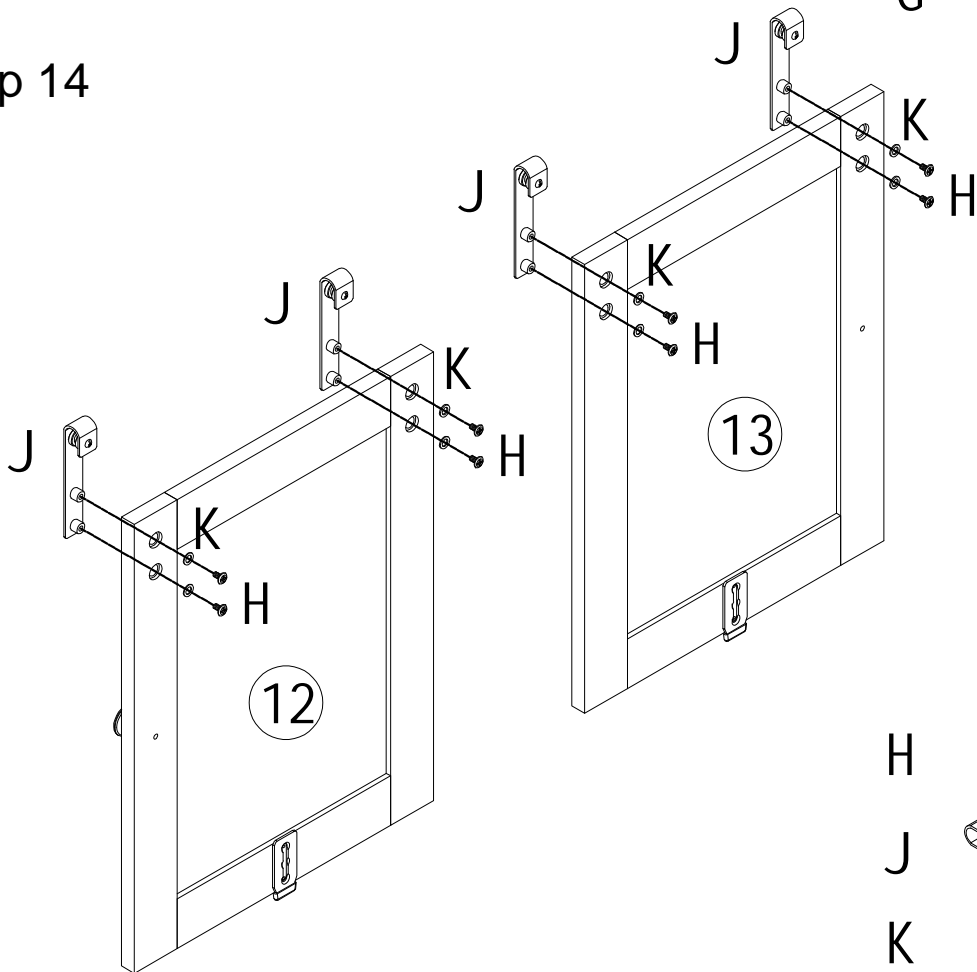

- F  x2
- G  x2

Step 14

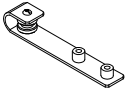

- H  x8
- J  x4
- K  x8

Assembly Steps

Step 15

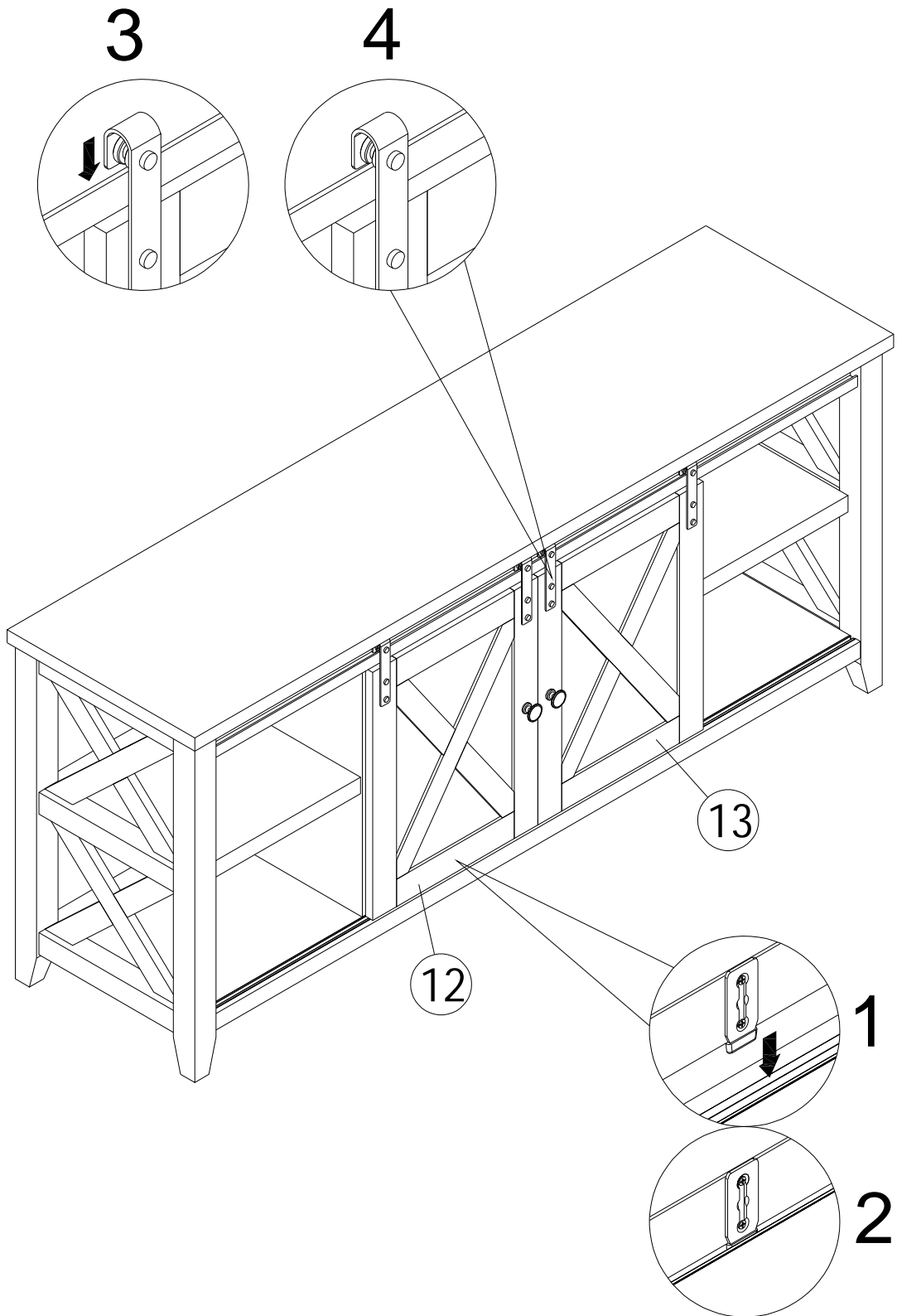

Assembly Steps

Step 17

