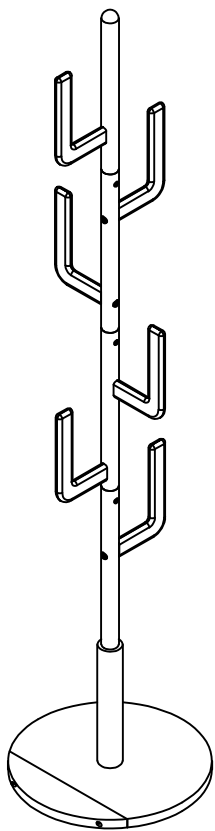

Illustration of Installation

Name: Cactus Coat Rack

Caution: (Installed) in the parts table and hardware table means that it has been installed in the finished product, and is not in the hardware bag!!!



List of Parts

No.	Name	Graph	Size	Amount
1	Baseplate 1		395*300*20MM	1
2	Baseplate 2		338*95*20MM	1
3	Upper column		420*φ40MM	1
4	Mid-upper column		420*φ40MM	1
5	Mid-lower column		420*φ40MM	1
6	Lower column		380*φ40MM	1
7	Bold lower column		280*φ55MM	1
8	Handle		205*125*15MM	7

List of Hardware

No.	Name	Graph	Size	Amount
A	Hexagon socket screw		M8*35MM	3
B	Flat gasket		M8*19MM	3
C	Hexagonal overmoulding wire		M7*30MM	4
D	Hexagonal overmoulding wire		M7*50MM	3
E	Hexagon screw		M6*50MM	7
F	Hexagon wrench		M4*57MM	1
G	Hexagon wrench		M5*57MM	1
H	Nonwoven fabric pad		φ20*3MM	5

This product has passed the wood inspection and paint inspection in full compliance with the national quality inspection standards. After passing the inspection, it will be released from the factory and sold after confirming that the packaging is intact.

For better service, please feel free to give us your opinions on after-sales service.

Name:	Wood Furniture
Qualification:	Pass
Grade:	Class 1

Standard:
GB/T 3324
GB/ 18584

Required
Workers



Inspector
QC 02

Name: Cactus Coat Rack

Step 1: Assemble the base plate

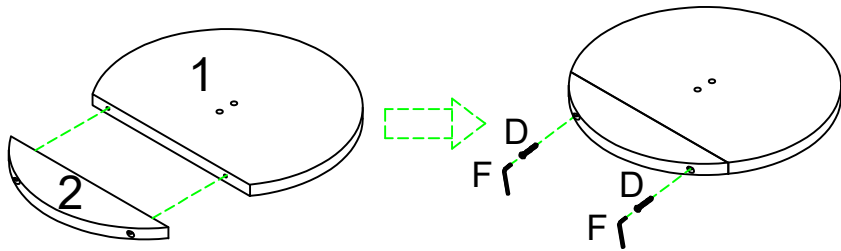

Caution: 1. After unpacking, please check the correct number of accessories against the instructions first.
2. As illustrated, first put the base plate 1 (1) and the base plate 2 (2) together, then use the hexagonal overmoulding wire (D) to pass through the side holes and use the L-shaped hexagonal wrench (F) to fix and tighten.

Step 2: Fix the bold lower column onto the base plate.

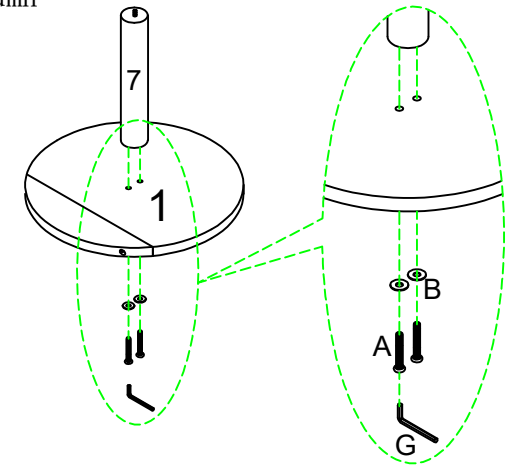

Insert the hexagonal socket screw (A) and flat gasket (B) through the base plate (1) as shown in the illustration, then fix the bold lower column, (7) and tighten it with the L shaped hexagonal wrench (G).

Step 3: Install the lower column

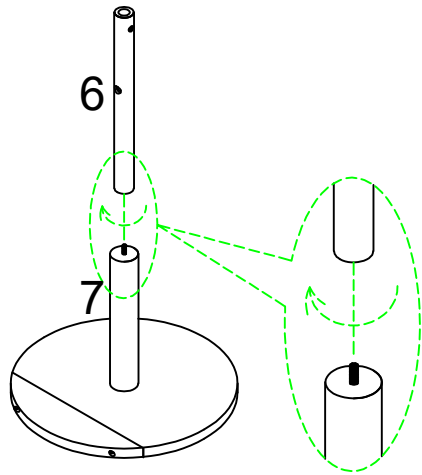

Tighten the lower column (6) into the thickened lower post in a clockwise direction as shown in the diagram.

Step 4: Install the mid-upper column

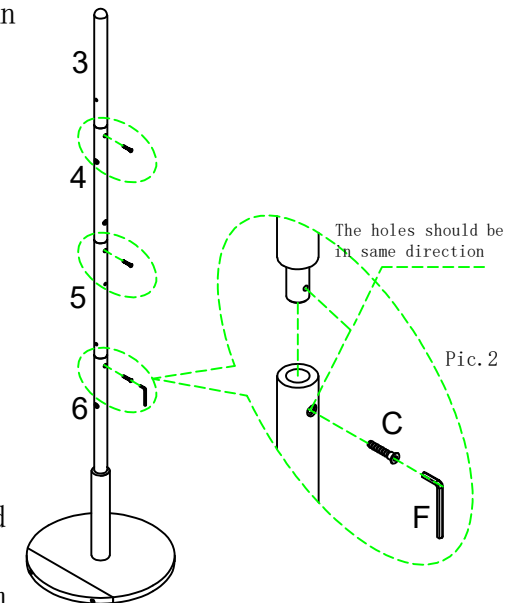

As illustrated, secure the mid-lower column (5) and the mid-upper column (4) and the upper column (3) in turn with the hexagonal overmoulding wire (C) and the hexagon wrench (F). Note that the columns are 7, 6, 5, 4, 3, from bottom to top.

Step 5: Install the handle

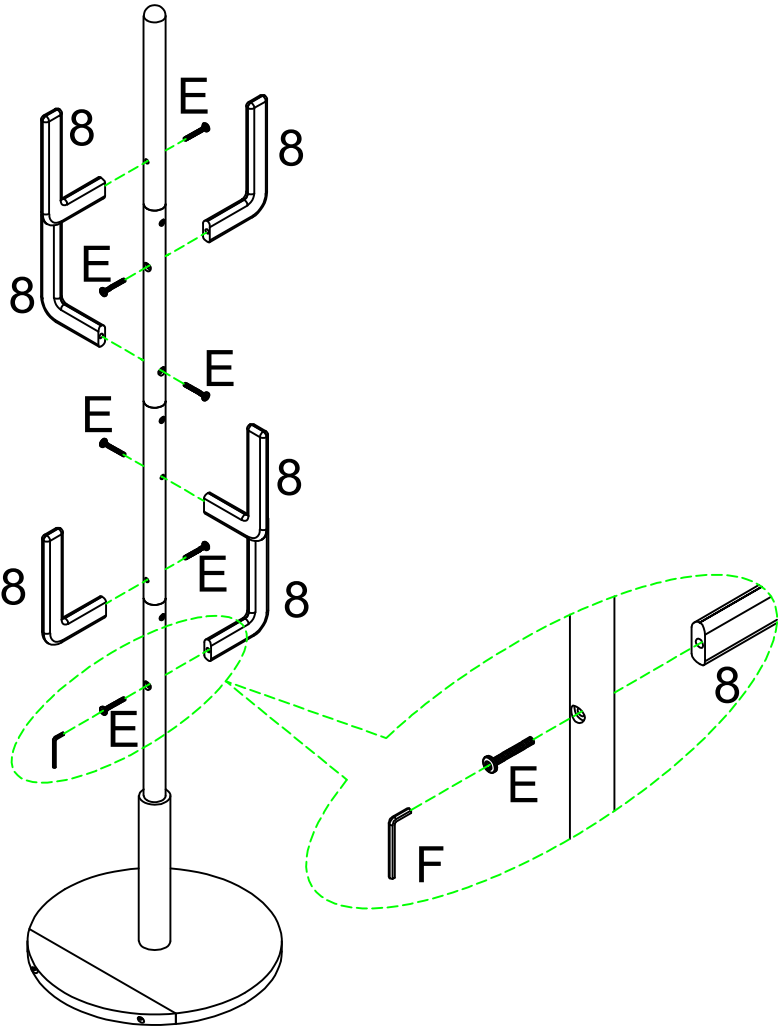

As illustrated, fix handle (8) to column using the hexagon screw (E) and fasten it using hexagon wrench (F).

(Caution: When installing the tabs, screw from the large hole into the small hole.)

Step 6: Install nonwoven fabric pad

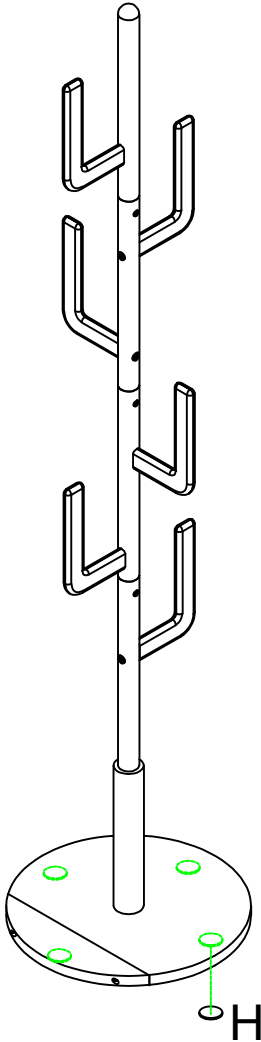

As illustrated, stick the nonwoven fabric pad (H) to the bottom of the base plate and finish the installation.