

ASSEMBLY INSTRUCTIONS  
INSTRUCTIONS DE MONTAGE

LOFT BED  
LIT MEZZANINE

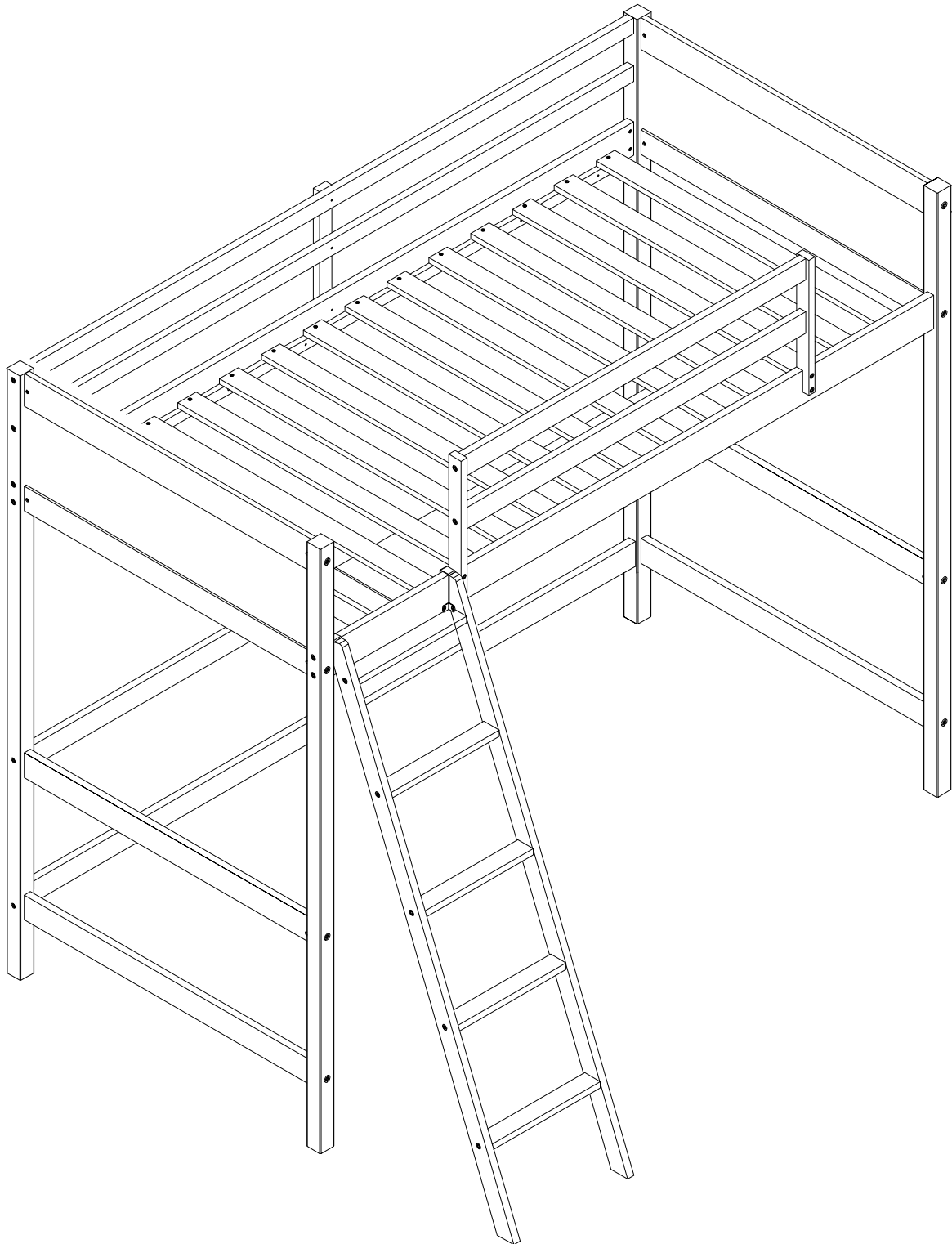

# ! SAFETY WARNING !

## ! AVERTISSEMENT DE SÉCURITÉ !







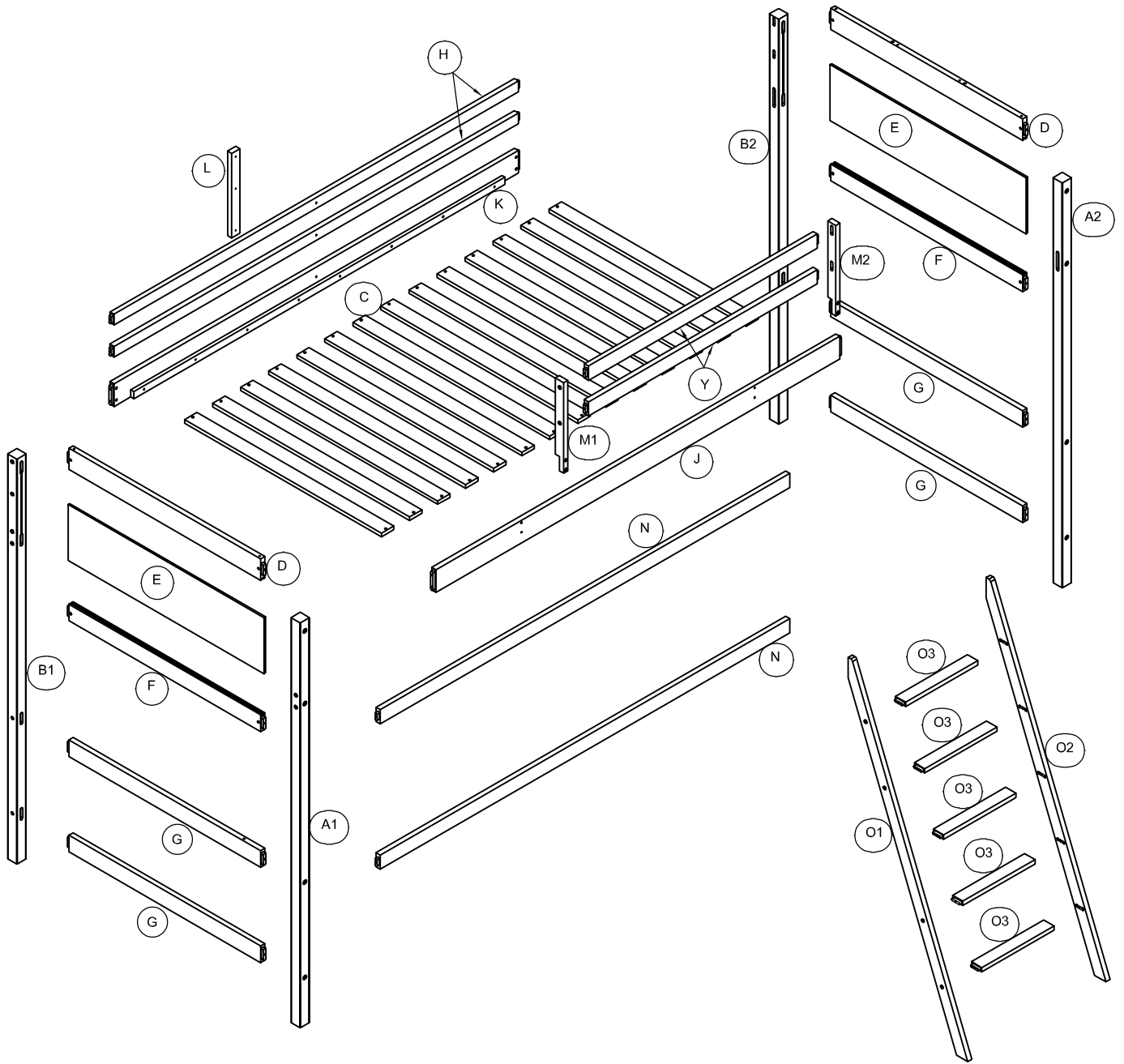

1. This bed is designed for use only mattress (es) meeting the following specifications on the loft bed  
Ce lit est conçu pour être utilisé uniquement avec un (des) matelas répondant aux spécifications suivantes sur le lit mezzanine.  
  
Up bed (Loft bed and tribed included)/Lit supérieur (lit mezzanine et tribed inclus)  

Bed type /Type de lit	Length/Longueur	Width/Largeur	Thickness/Épaisseur
Twin Standard/Jumeau Standard	74"-75"	37 1/2" - 38 1/2"	6" max
2. Replacement parts, including additional guardrails, maybe obtained from any of our dealers.  
Les pièces de rechange, y compris les garde-corps supplémentaires, peuvent être obtenues auprès de l'un de nos concessionnaires.
3. Follow the information on the warnings appearing on the loft bed, end structure and on the carton.  
Do not remove warning label from bed.  
Suivez les informations figurant sur les avertissements apparaissant sur le lit mezzanine, la structure de l'extrémité et sur le carton. Ne retirez pas l'étiquette d'avertissement du lit.
4. Always use the recommended size mattresses or mattress supports, or both, to help prevent the likelihood of entrapment or falls.  
Utilisez toujours les matelas ou supports de matelas de taille recommandée, ou les deux, pour aider à prévenir les risques d'enchevêtrement ou de chutes.
5. Surface of mattress must be at least 5" (127mm) below the upper edge of guardrails.  
La surface du matelas doit être d'au moins 5" (127 mm) en dessous du bord supérieur des garde-corps.
6. Do not allow children under 6 years of age to use the loft bed./Ne pas permettre aux enfants de moins de 6 ans d'utiliser le lit mezzanine.
7. Periodically check and ensure that the guardrail, ladder, and other components are in their proper position, free from damage, and that all connectors are tight.  
Vérifiez périodiquement et assurez-vous que le garde-corps, l'échelle et les autres composants sont en place, sans dommage, et que tous les connecteurs sont bien serrés.
8. Do not allow horseplay on or under the bed and prohibit jumping on the bed.  
Ne permettez pas de jeux brusques sur ou sous le lit et interdisez les sauts sur le lit.
9. Always use the ladder for entering and leaving the loft bed./Utilisez toujours l'échelle pour monter et descendre du lit mezzanine.
10. Do not use substitute part. Contact the manufacture or dealer for replacement part.  
Ne pas utiliser de pièce de remplacement. Contactez le fabricant ou le concessionnaire pour obtenir une pièce de rechange.
11. Use of a night light may provide added safety precaution for a child using the loft bed.  
L'utilisation d'une veilleuse peut offrir une précaution de sécurité supplémentaire pour un enfant utilisant le lit mezzanine.
12. Always use guardrails on both long sides of the loft bed. If the loft bed will be placed next to the wall, the guardrail that runs the full length of the bed should be placed against the wall to prevent entrapment between the bed and wall.  
Utilisez toujours les garde-corps sur les deux côtés longs du lit mezzanine. Si le lit mezzanine est placé à côté du mur, le garde-corps qui couvre toute la longueur du lit doit être placé contre le mur pour empêcher l'enchevêtrement entre le lit et le mur.
13. The use of water or sleep flotation mattresses is prohibited./L'utilisation de matelas à eau ou de flottaison est interdite.
14. STRANGULATION HAZARD - Never attach or hang items to any part of the loft bed that are not designed for use with the bed, for example, but not limited to, hook, belts and jump ropes.  
RISQUE DE STRANGULATION - Ne jamais attacher ou suspendre des objets à toute partie du lit mezzanine qui ne sont pas conçus pour être utilisés avec le lit, par exemple, mais sans s'y limiter, des crochets, des ceintures et des cordes à sauter.
15. Keep these instruction for future reference./Conservez ces instructions pour référence future.
16. Prohibit more than one person on upper bunk/Interdire à plus d'une personne de se trouver sur la couchette supérieure.
17. We recommend assembling your bunk bed on the shipping carton to protect your floor or carpet.  
Nous recommandons d'assembler votre lit superposé sur le carton d'expédition pour protéger votre sol ou votre moquette.
18. Be certain all staples are out of the box before beginning assembly on the shipping carton.  
Assurez-vous que toutes les agrafes sont hors du carton avant de commencer l'assemblage sur le carton d'expédition.



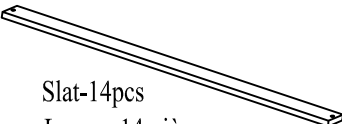
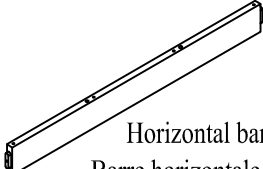
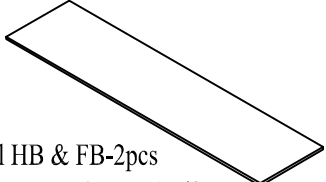
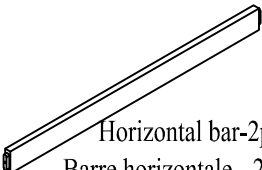
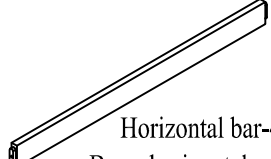
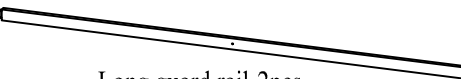

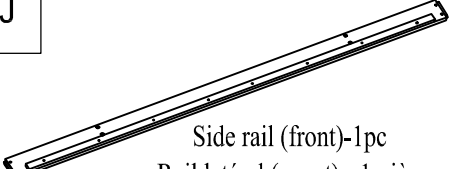
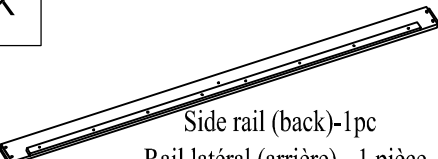
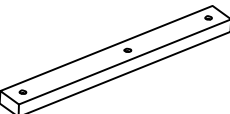
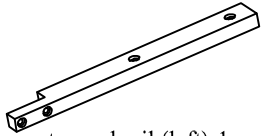
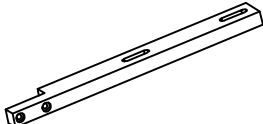
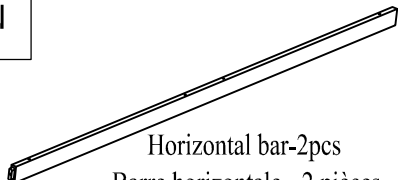
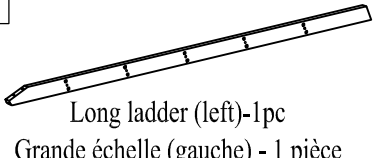
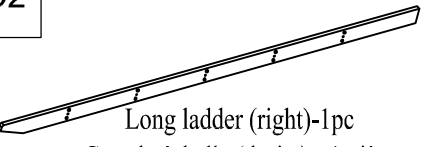
DETAIL VIEW  
VUE DÉTAILLÉE

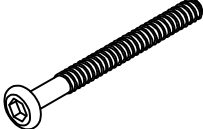

# PART LIST / LISTE DES PIÈCES

<p><b>A1</b></p>  <p>Leg (Left Front)-1pc Pied (Avant Gauche) - 1 pièce</p>	<p><b>A2</b></p>  <p>Leg (Right Front)-1pc Pied (Avant Droit) - 1 pièce</p>	<p><b>B1</b></p>  <p>Leg (Left Back)-1pc Pied (Arrière Gauche) - 1 pièce</p>
<p><b>B2</b></p>  <p>Leg (Right Back)-1pc Pied (Arrière Droit) - 1 pièce</p>	<p><b>C</b></p>  <p>Slat-14pcs Lame - 14 pièces</p>	<p><b>D</b></p>  <p>Horizontal bar-2pcs Barre horizontale - 2 pièces</p>
<p><b>E</b></p>  <p>Panel HB &amp; FB-2pcs Panneau HB &amp; FB - 2 pièces</p>	<p><b>F</b></p>  <p>Horizontal bar-2pcs Barre horizontale - 2 pièces</p>	<p><b>G</b></p>  <p>Horizontal bar-4pcs Barre horizontale - 4 pièce</p>
<p><b>H</b></p>  <p>Long guard rail-2pcs Longue barre de garde - 2 pièces</p>	<p><b>Y</b></p>  <p>Short guard rail-2pcs Petite barre de garde - 2 pièces</p>	<p><b>J</b></p>  <p>Side rail (front)-1pc Rail latéral (avant) - 1 pièce</p>
<p><b>K</b></p>  <p>Side rail (back)-1pc Rail latéral (arrière) - 1 pièce</p>	<p><b>L</b></p>  <p>Vertical guard rail-1pc Barre de garde verticale - 1 pièce</p>	<p><b>M1</b></p>  <p>Support guard rail (left)-1pc Support de garde (gauche) - 1 pièce</p>
<p><b>M2</b></p>  <p>Support guard rail (right)-1pc Support de garde (droit) - 1 pièce</p>	<p><b>N</b></p>  <p>Horizontal bar-2pcs Barre horizontale - 2 pièces</p>	<p><b>O1</b></p>  <p>Long ladder (left)-1pc Grande échelle (gauche) - 1 pièce</p>
<p><b>O2</b></p>  <p>Long ladder (right)-1pc Grande échelle (droite) - 1 pièce</p>	<p><b>O3</b></p>  <p>Ladder Step-5pcs Marche d'échelle - 5 pièces</p>	

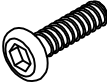
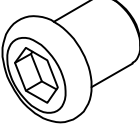
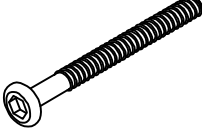
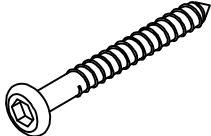
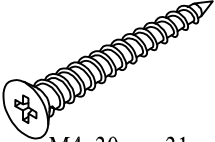
# HARDWARE LIST / LISTE DU MATÉRIEL

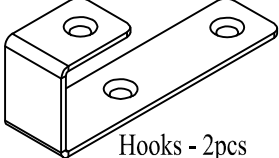
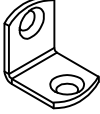
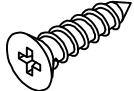
<p>1</p>  <p>Hex-Head Bolts 1/4"x80mm-32pcs Boulons à tête hexagonale 1/4"x80mm - 32 pièces</p>	<p>2</p>  <p>Horizontal-hole bolts 1/4"x13mm-26pcs Boulons à trous horizontaux 1/4"x13mm - 26 pièces</p>	<p>3</p>  <p>Hex-Head Bolts 1/4"x30mm - 4pcs Boulons à tête hexagonale 1/4"x30mm - 4 pièces</p>
<p>4</p>  <p>Hex-Head Canopy 1/4"x15mm-4pcs Canopy à tête hexagonale 1/4"x15mm - 4 pièces</p>	<p>5</p>  <p>Hex-Head Bolts 1/4"x60mm-10pcs Boulons à tête hexagonale 1/4"x60mm - 10 pièces</p>	<p>6</p>  <p>Screw 1/4"x70mm - 4pcs Vis 1/4"x70mm - 4 pièces</p>
<p>7</p>  <p>Wood screws M4x30mm-31 pcs Vis à bois M4x30mm - 31 pièces</p>	<p>8</p>  <p>Allen Key-1pc Clé Allen - 1 pièce</p>	<p>9</p>  <p>Hooks - 2pcs Crochets - 2 pièces</p>
<p>10</p>  <p>Metal bracket - 2pcs Support en métal - 2 pièces</p>	<p>11</p>  <p>Wood screws M3x15mm-10pcs Vis à bois M3x15mm - 10 pièces</p>	

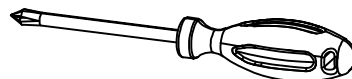

Assembly Tool Required (Not Included)  
Outil de montage requis (non inclus)

# STEP/ÉTAPE 1:

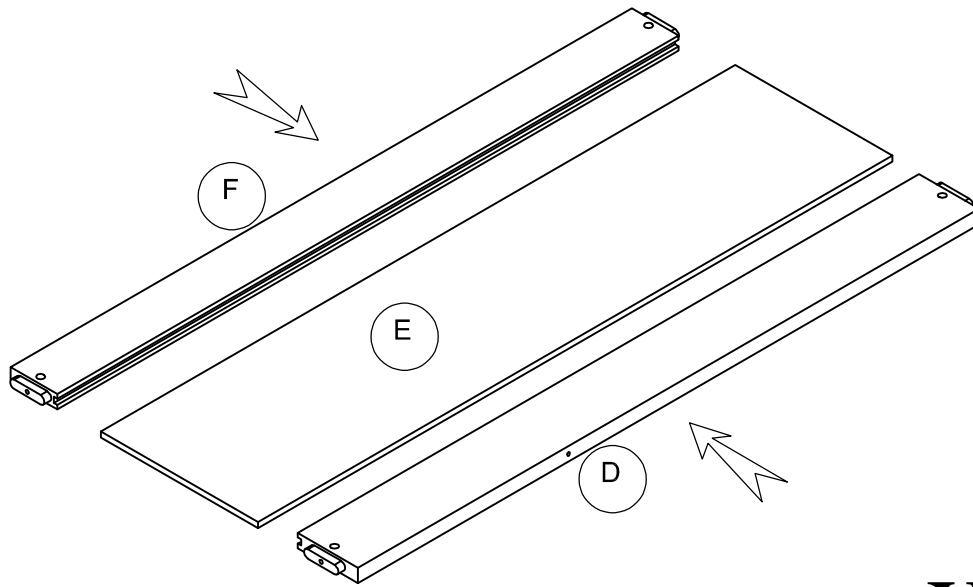

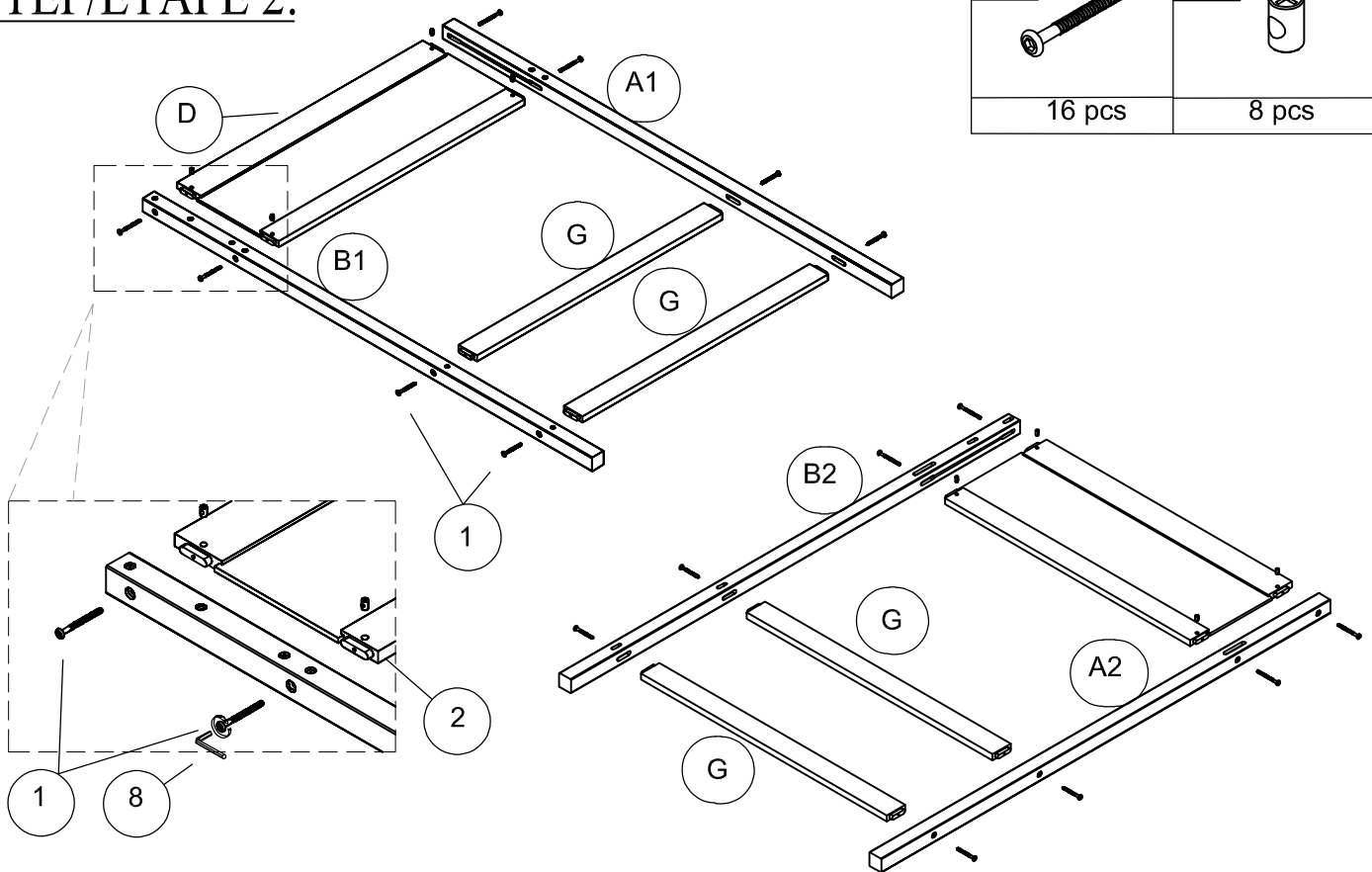

X2

# STEP/ÉTAPE 2:

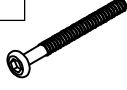

# STEP/ÉTAPE 3:

1		2	
16 pcs		8 pcs	

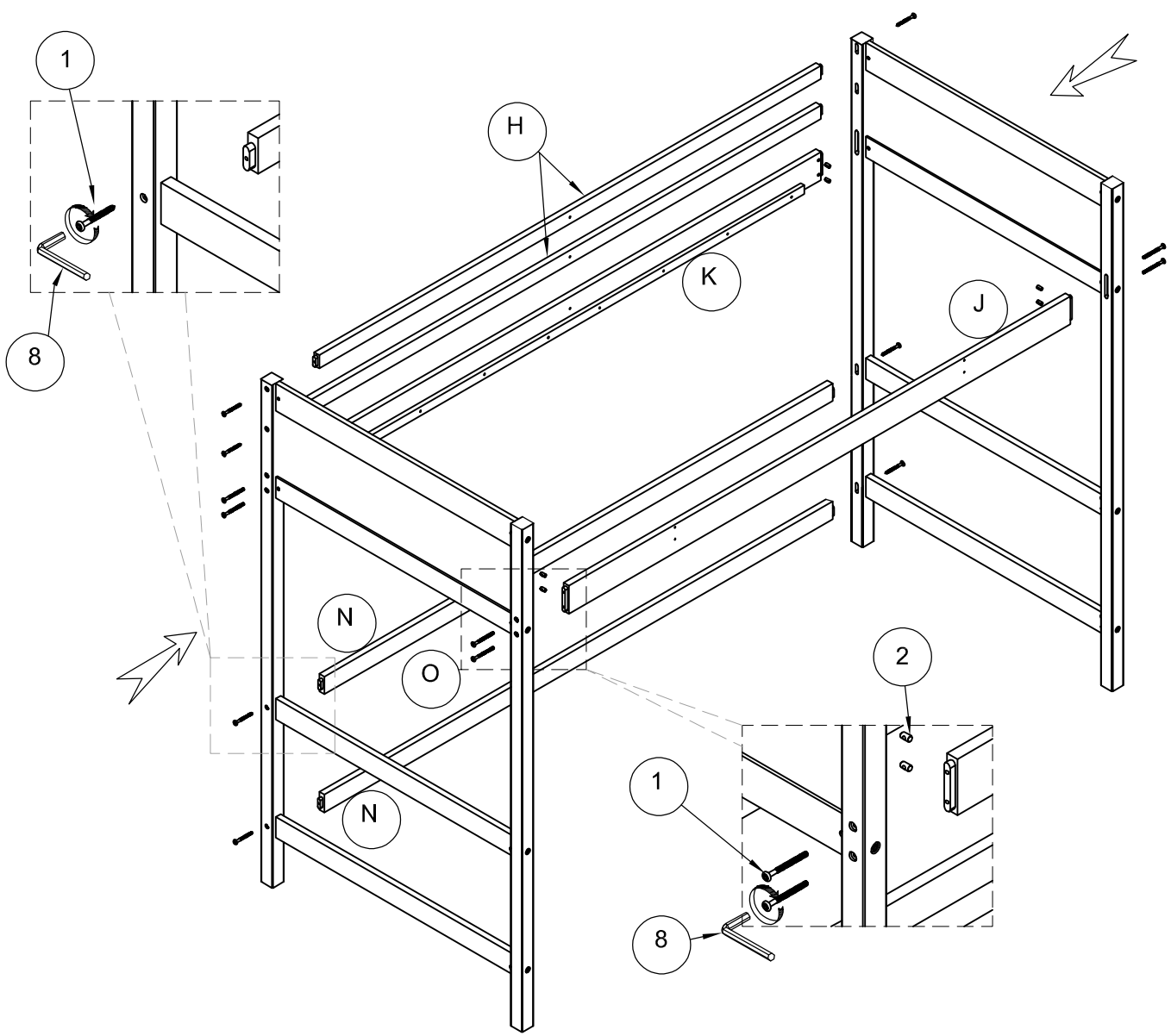

## STEP/ÉTAPE 4:

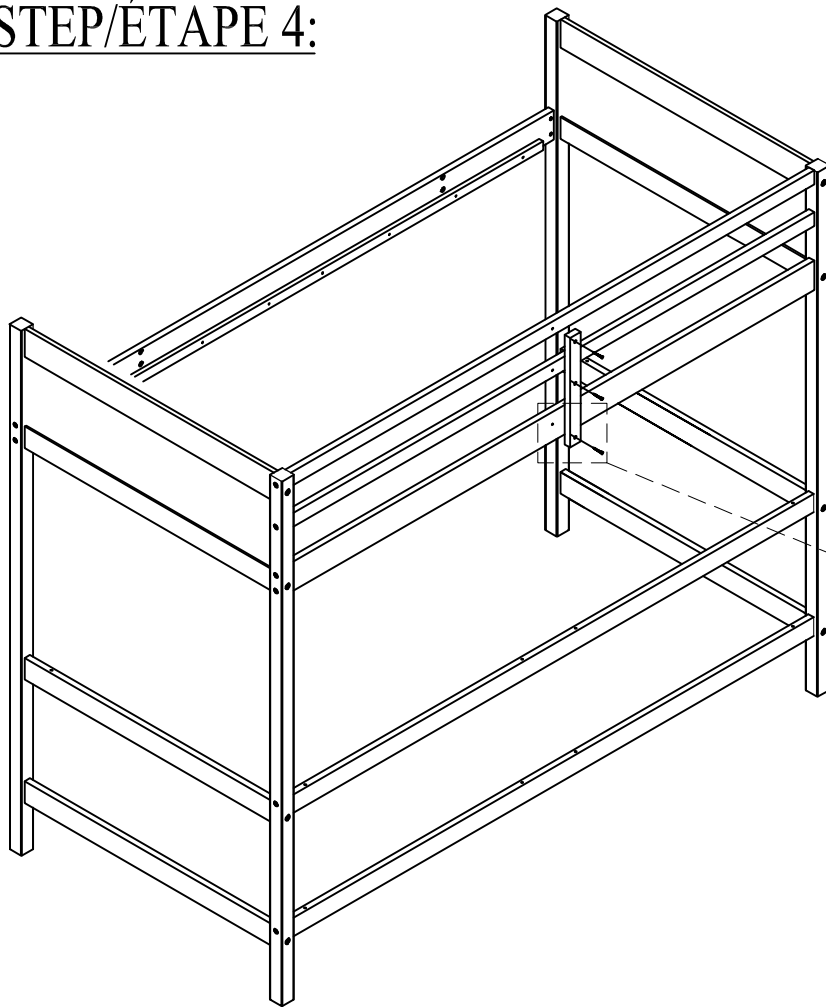

7



3 pcs

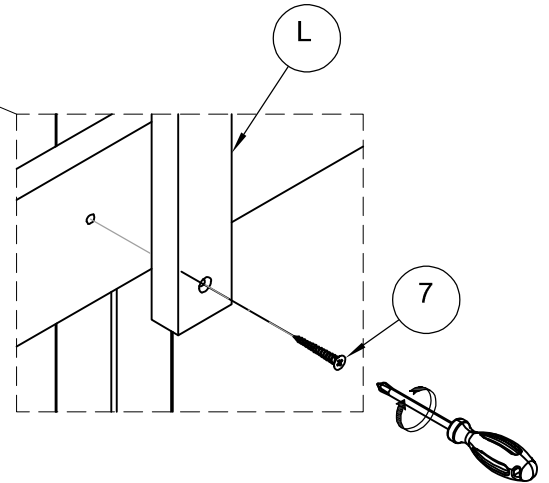

## STEP/ÉTAPE 5:

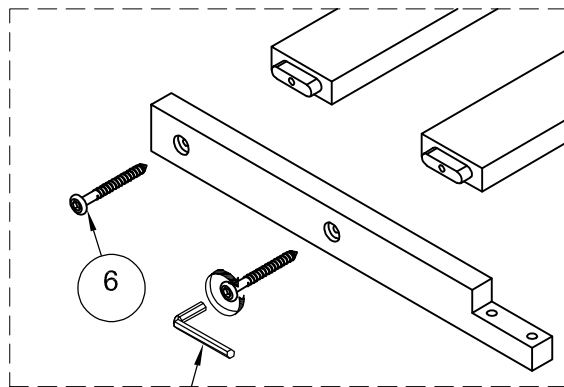

6

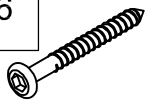

4 pcs

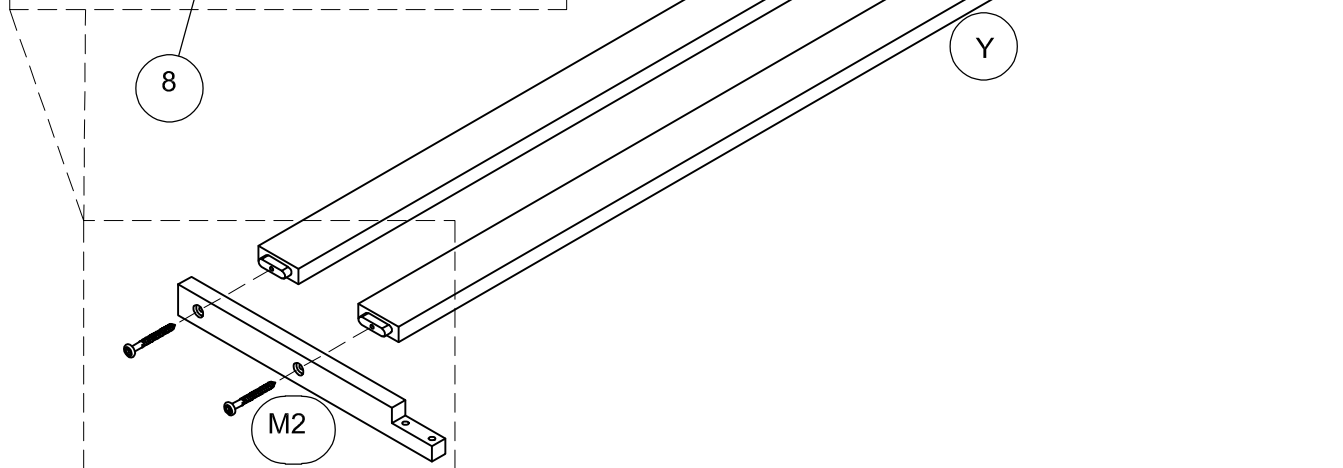

# STEP/ÉTAPE 6:

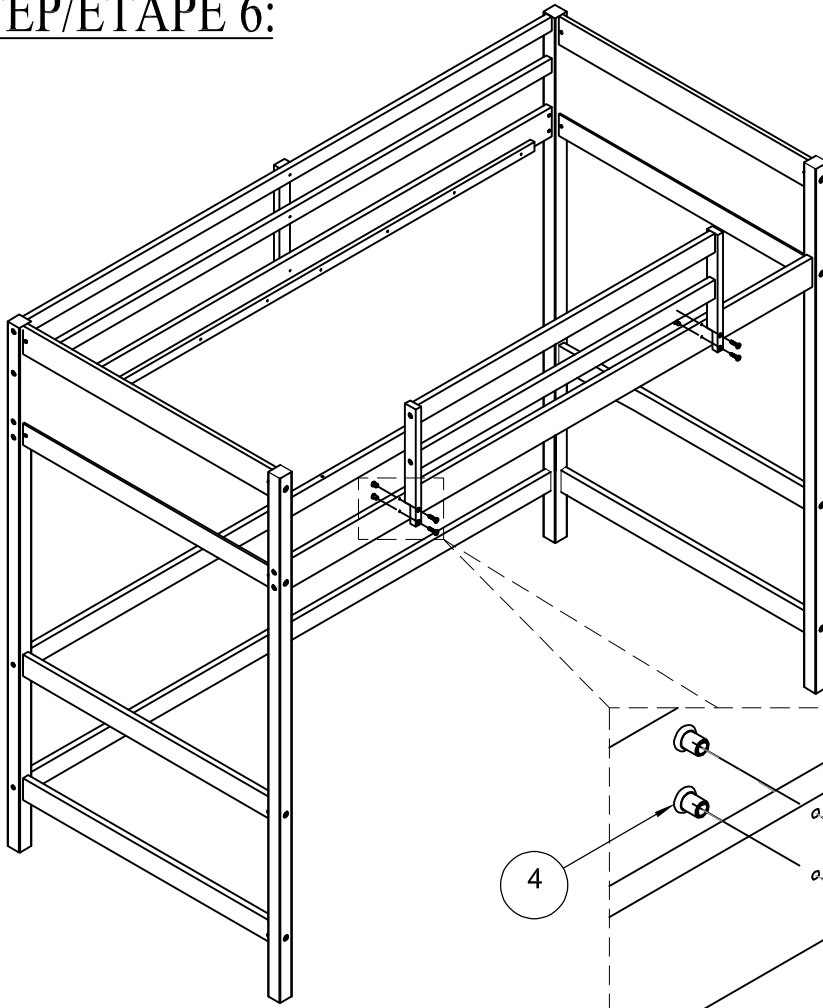

3		4	
4 pcs		4 pcs	

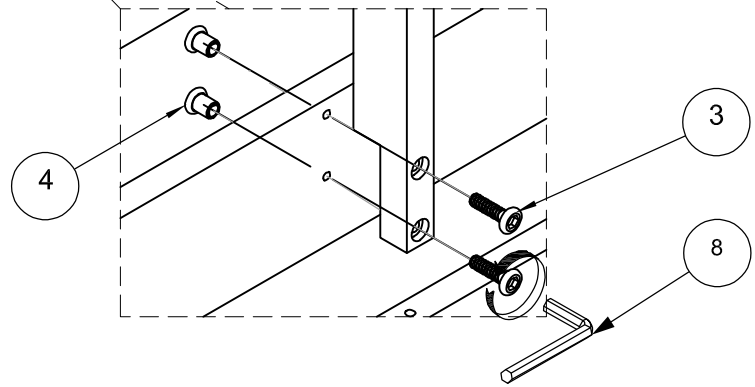

# STEP/ÉTAPE 7:

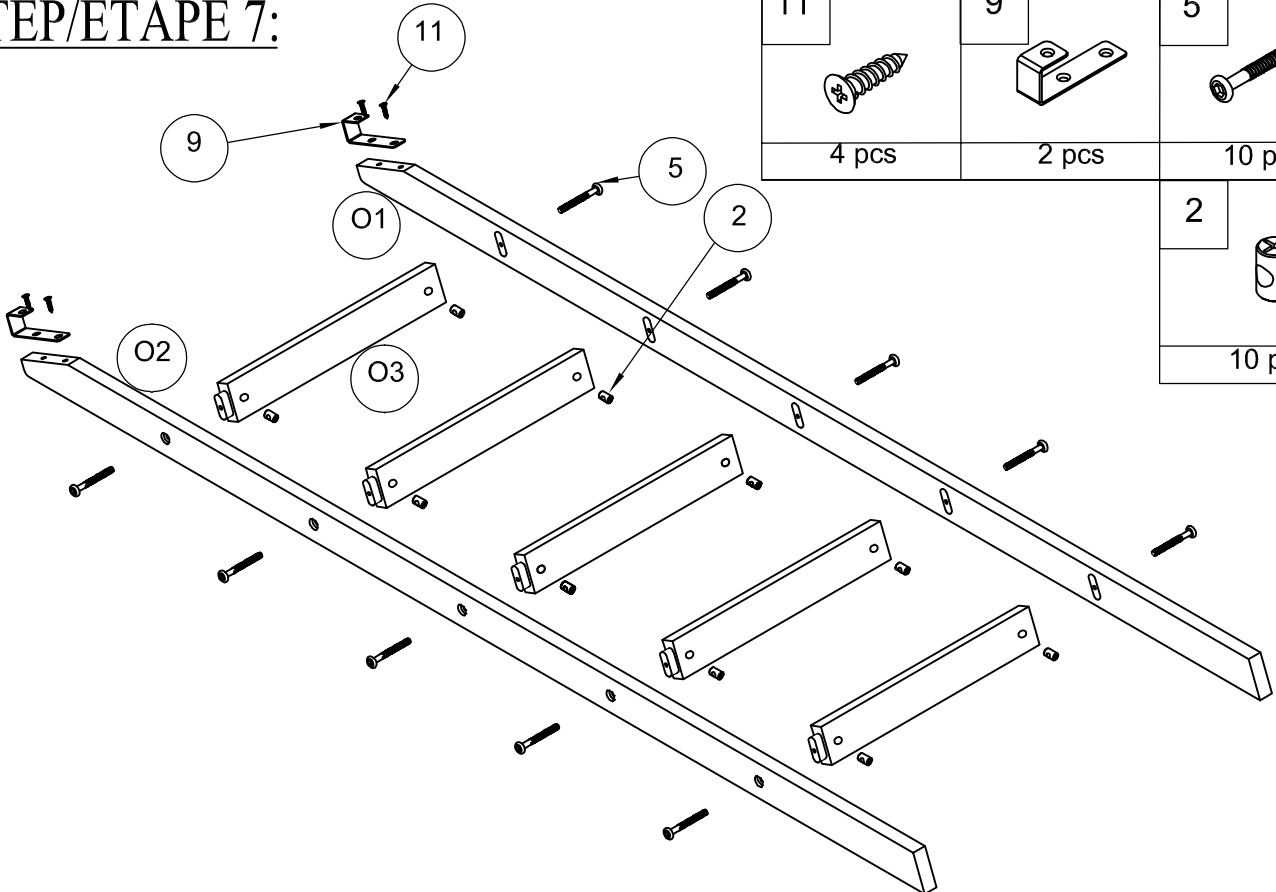

11		9		5	
4 pcs		2 pcs		10 pcs	
				2	
				10 pcs	

## STEP/ÉTAPE 8:

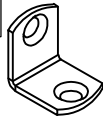
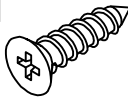
10		11	
2 pcs		6 pcs	

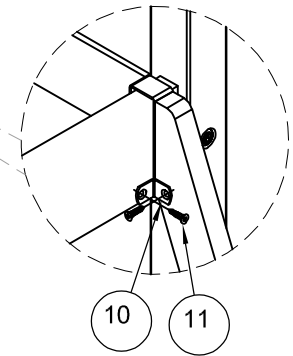
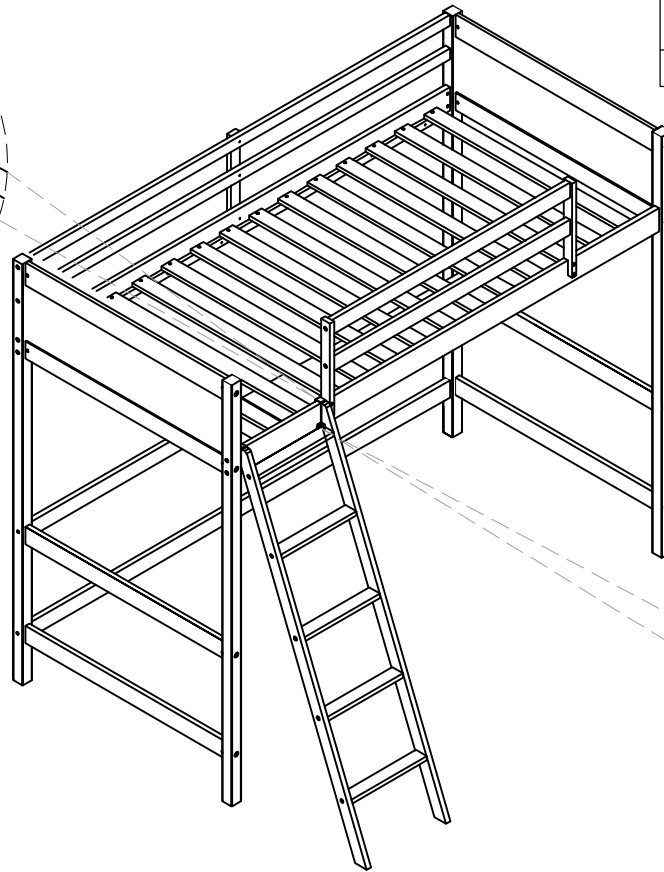
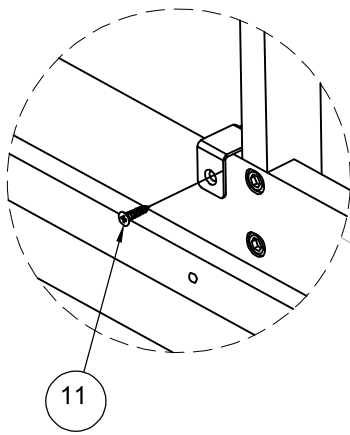

## STEP/ÉTAPE 9:

NOTE: Please make sure the bed slats close to the side rail before locking the screws to avoid breakage. This step is required for both the left and right sides. Moreover, please do not lock the screws of the bed slats at the outermost edge to avoid damaging.

REMARQUE : Veuillez vous assurer que les lattes du lit sont bien ajustées contre le rail latéral avant de verrouiller les vis pour éviter tout dommage. Cette étape est nécessaire pour les côtés gauche et droit. De plus, ne verrouillez pas les vis des lattes du lit à l'extrémité la plus extérieure pour éviter d'endommager.

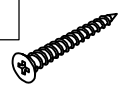
7	
28 pcs	

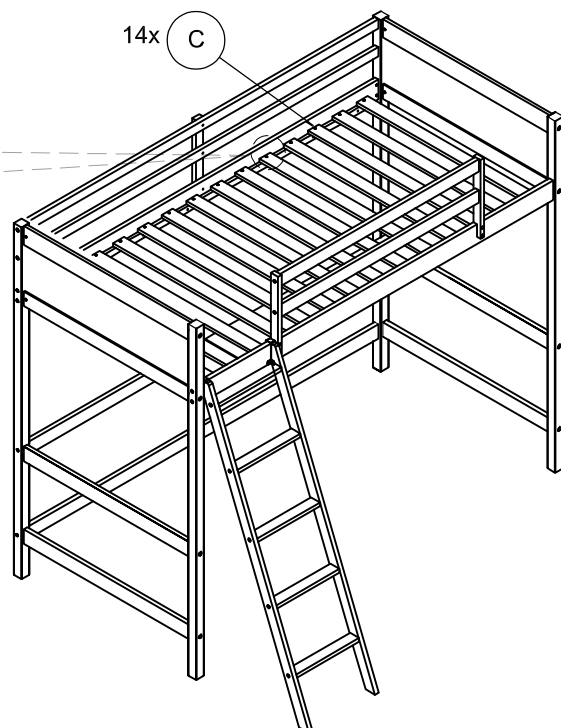
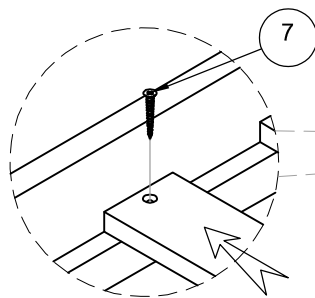

# COMPLETE/COMPLÉTÉ

