



Read this instruction carefully. See hardware and furniture part list for guidance. Be sure all parts are complete, before you assemble. Place all wooden furniture parts on a clean and flat soft surface to prevent from being scratched. Follow the figure to start assembling.

CAUTIONS : 1. Do not FULLY - TIGHTEN the nut or nut bolt until all nut or bolt is ready assembled.
 2. Do not OVER - TIGHTEN the nut or bolt to avoid causing damages to the thread.
 3. Keep all hardware parts out of reach of children.

NOTE : THE LIST AND QUANTITY SHOWN ARE FOR 1 UNIT ASSEMBLY.
 Tool needed : Screwdriver (not provider).

PART LIST			
ITEM	DESCRIPTION	BOX	QTY
A	HEADBOARD	1	1 PC
B	FOOTBOARD	2	1 PC
C	SIDE RAIL	2	2 PCS
D	SUPPORT WOOD	2	6 PCS
E	CENTER RAIL	2	1 PC
F	CENTER SUPPORT	2	2 PCS
G	CENTER SUPPORT LEG	2	3 PCS
H	BED LEG	2	4 PCS
I	BED SLAT	2	26 PCS

HARDWARE LIST (BOX : 2)		
ITEM	DESCRIPTION	QTY
1	JCBC BOLT M6 x 20mm 	6 PCS
2	JCBC BOLT M6 x 35mm 	14 PCS
3	M6 FLAT WASHER 	8 PCS
4	M6 SPRING WASHER 	8 PCS
5	WOOD SCREW M4 x 20mm 	2 PCS
6	WOOD SCREW M3.5 X 16mm 	8 PCS
7	BED SLAT SIDE FITTER 	26 PCS
8	BED SLAT CENTER FITTER 	13 PCS
9	M4 ALLEN KEY (BALL SHAPE) 	1 PC
10	M5 ALLEN KEY (BALL SHAPE) 	1 PC

STEP 1

STEP 1.1

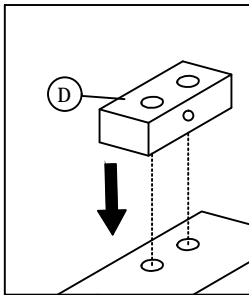

STEP 1.2

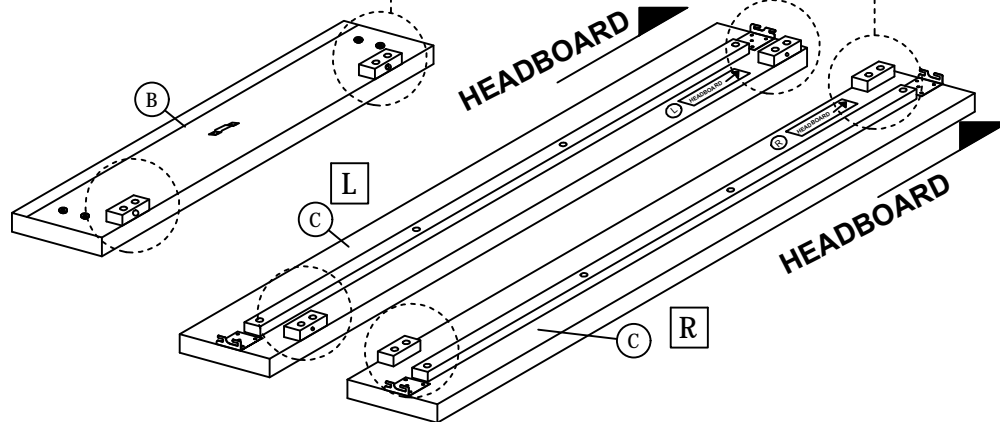
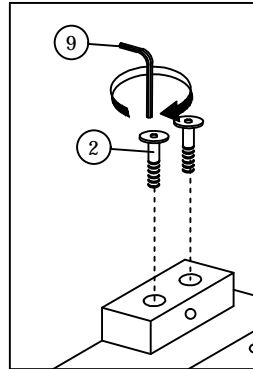

STEP 2

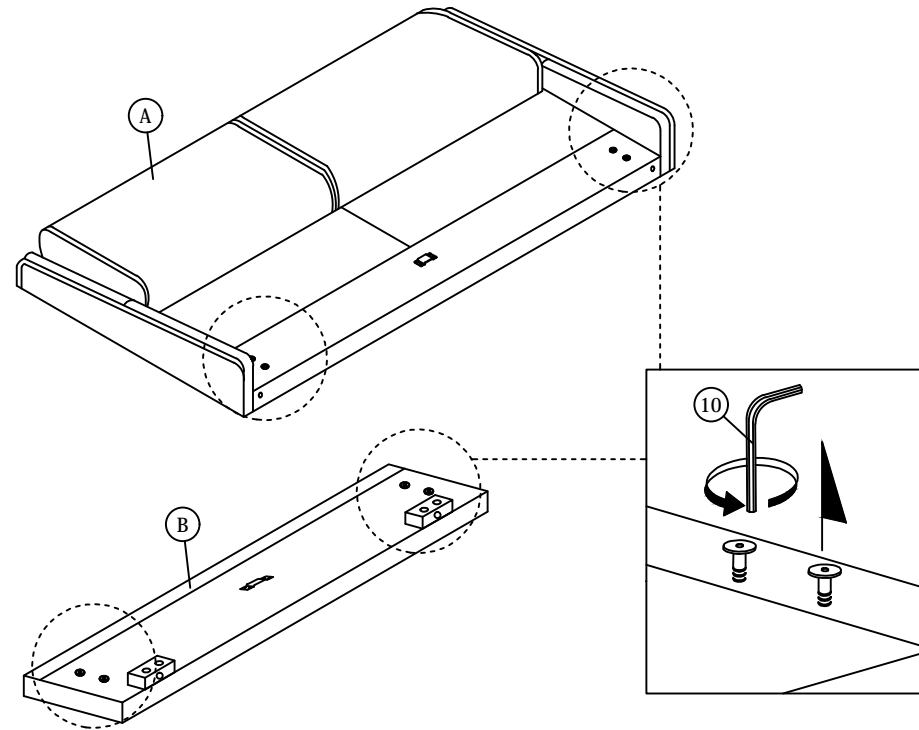

Loosen the pre-inserted bolt on the headboard and footboard using Allen key ball shape (10).

ASSEMBLY INSTRUCTIONS

STEP 3

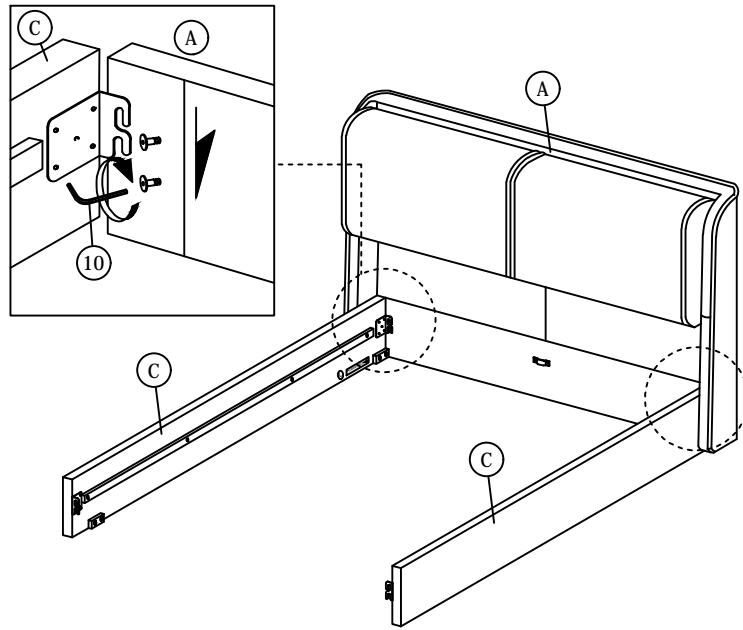

STEP 4

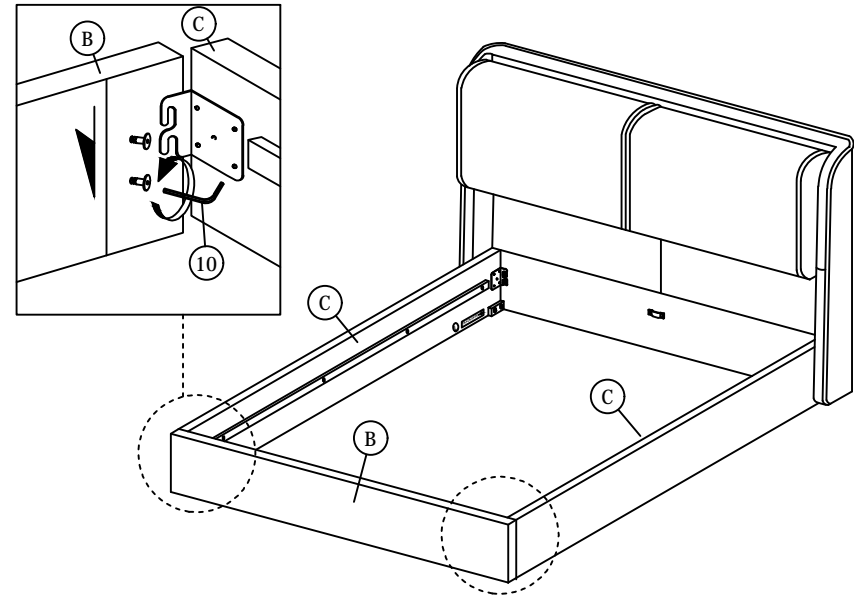

STEP 5

STEP 5.1

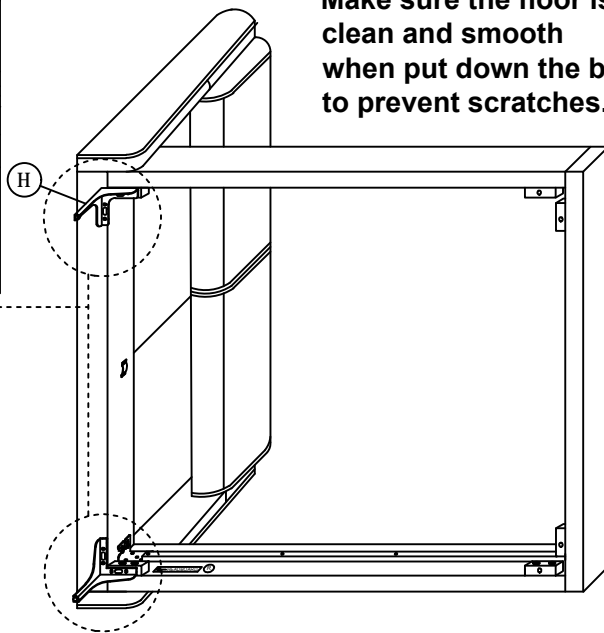
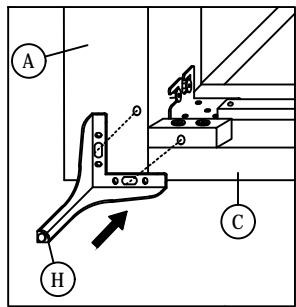

STEP 5.2

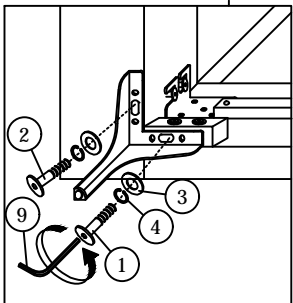

STEP 6

NOTE :

Make sure the floor is clean and smooth when put down the bed to prevent scratches.

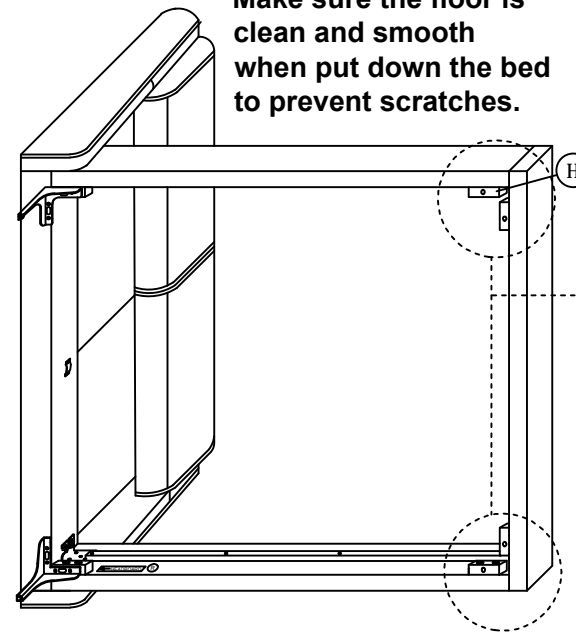

STEP 6.1

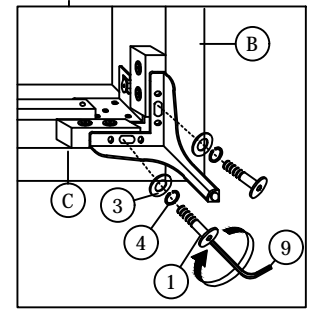
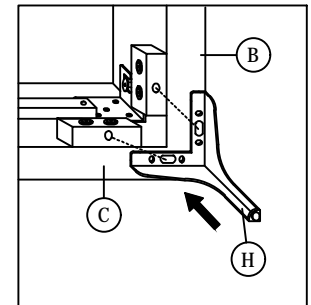

STEP 6.2

ASSEMBLY INSTRUCTIONS

STEP 7

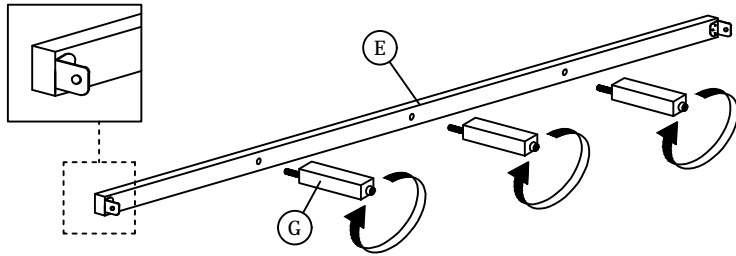

STEP 8

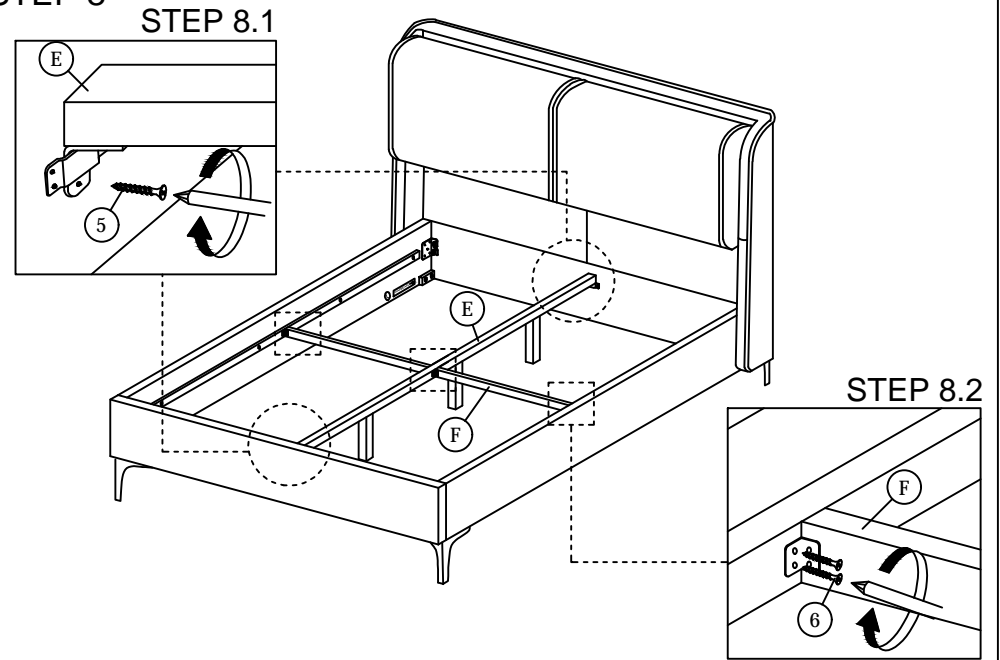

STEP 9

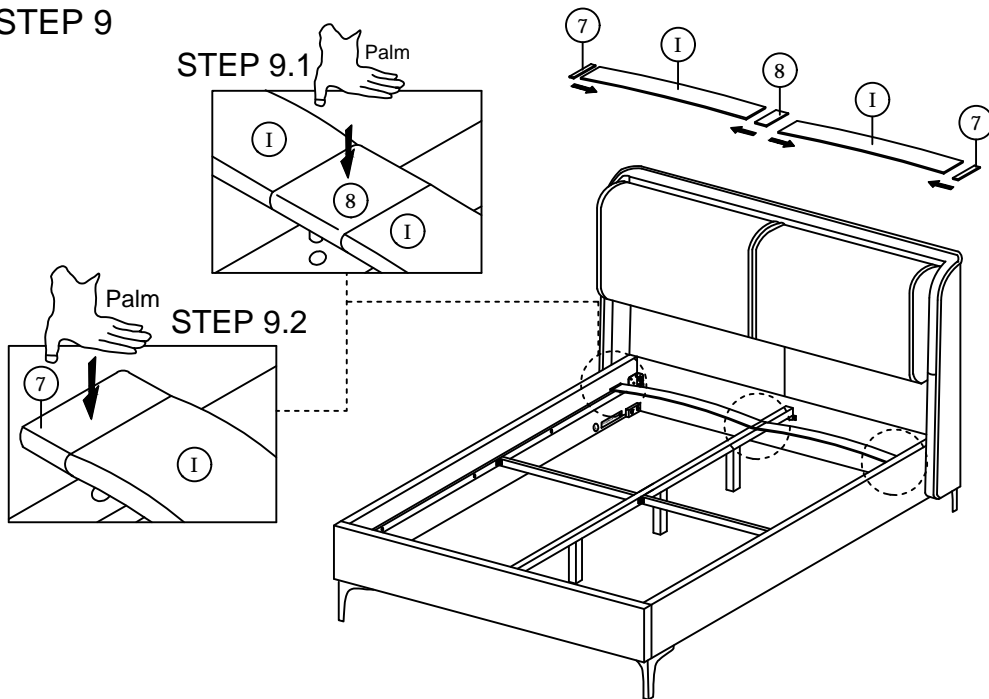

STEP 10

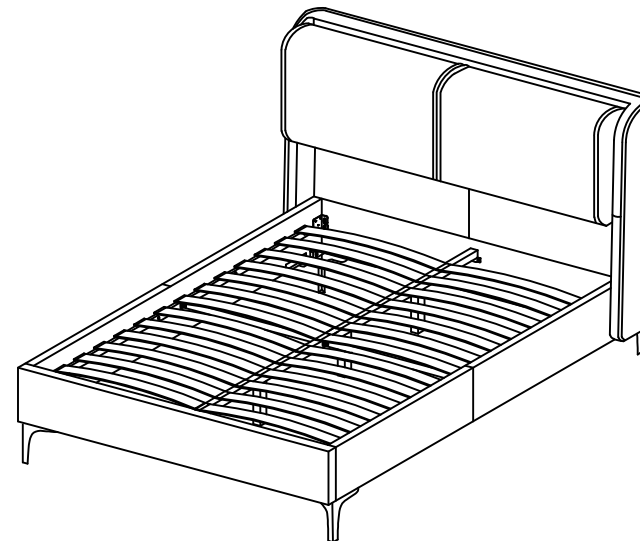





* When moving the bed position, the center support legs must be adjust to be straight to avoid any broken problem.

Read this instruction carefully. See hardware and furniture part list for guidance. Be sure all parts are complete, before you assemble. Place all wooden furniture parts on a clean and flat soft surface to prevent from being scratched. Follow the figure to start assembling.

CAUTIONS : 1. Do not FULLY - TIGHTEN the nut or nut bolt until all nut or bolt is ready assembled.
 2. Do not OVER - TIGHTEN the nut or bolt to avoid causing damages to the thread.
 3. Keep all hardware parts out of reach of children.

NOTE : THE LIST AND QUANTITY SHOWN ARE FOR 1 UNIT ASSEMBLY.
 Tool needed : Screwdriver (not provider).

PART LIST			
ITEM	DESCRIPTION	BOX	QTY
A	NIDHTSTAND	1	1 PC
B	LEG	1	4 PCS
C	HANDLE	1	2 PCS
D	HANDLE SCREW	1	4 PCS
E	FLAT WASHER	1	4 PCS
F	DRAWER	1	2 PCS

HARDWARE LIST (BOX : 1)		
ITEM	DESCRIPTION	QTY
1	JCBC BOLT M6 x 20mm 	8 PCS
2	M6 FLAT WASHER 	8 PCS
3	M6 SPRING WASHER 	8 PCS
4	M4 ALLEN KEY (BALL SHAPE) 	1 PC

STEP 1

Note:
 Open the last of drawer and take out all the parts.

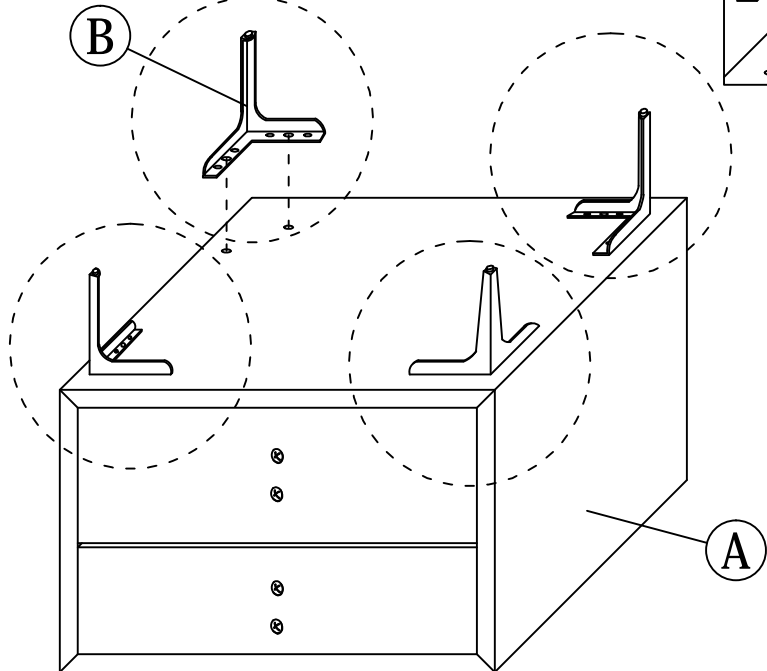
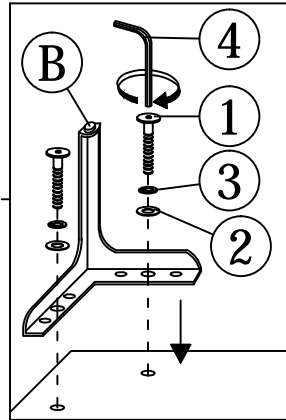

STEP 2

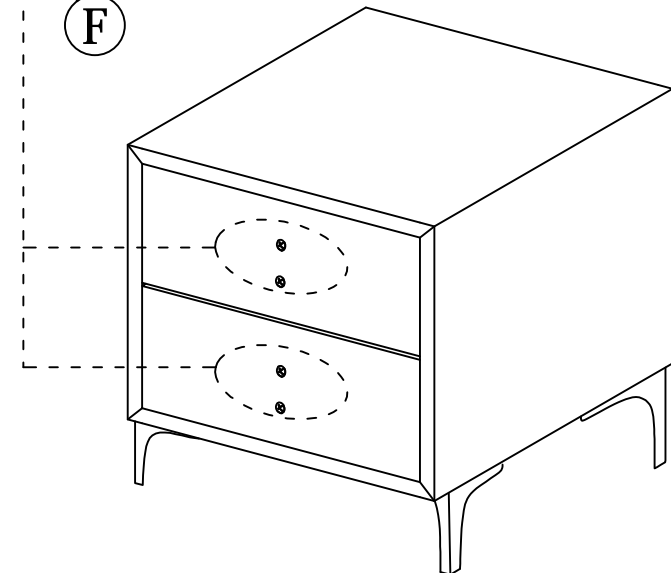
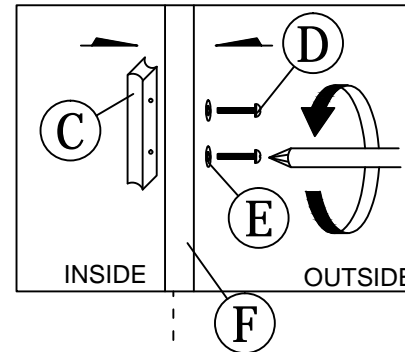

ASSEMBLY INSTRUCTIONS

STEP 3

Note :
Hold the handle flat and
then tighten the screws

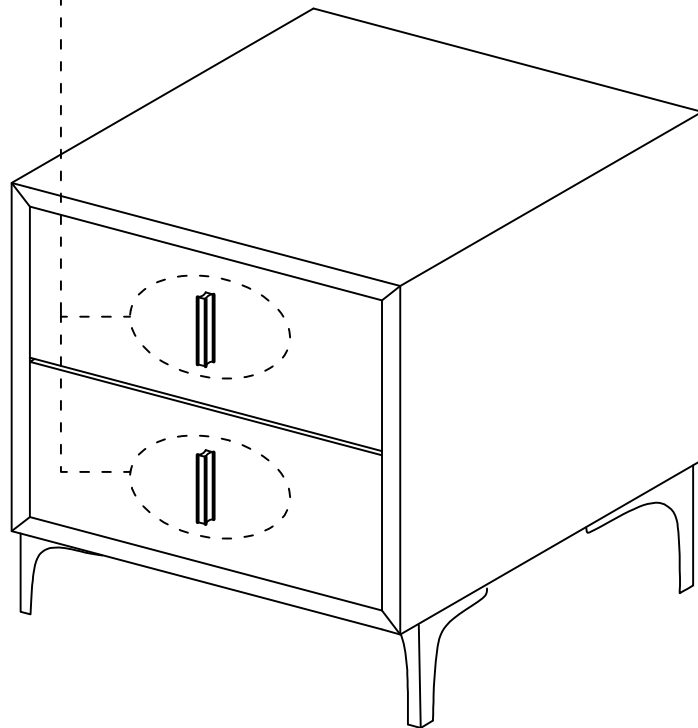
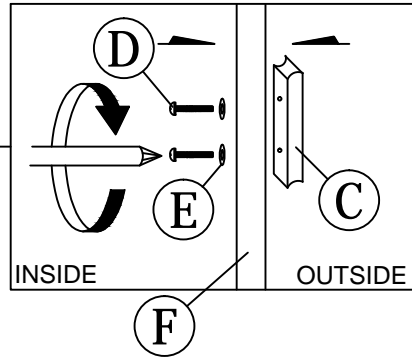

STEP 4

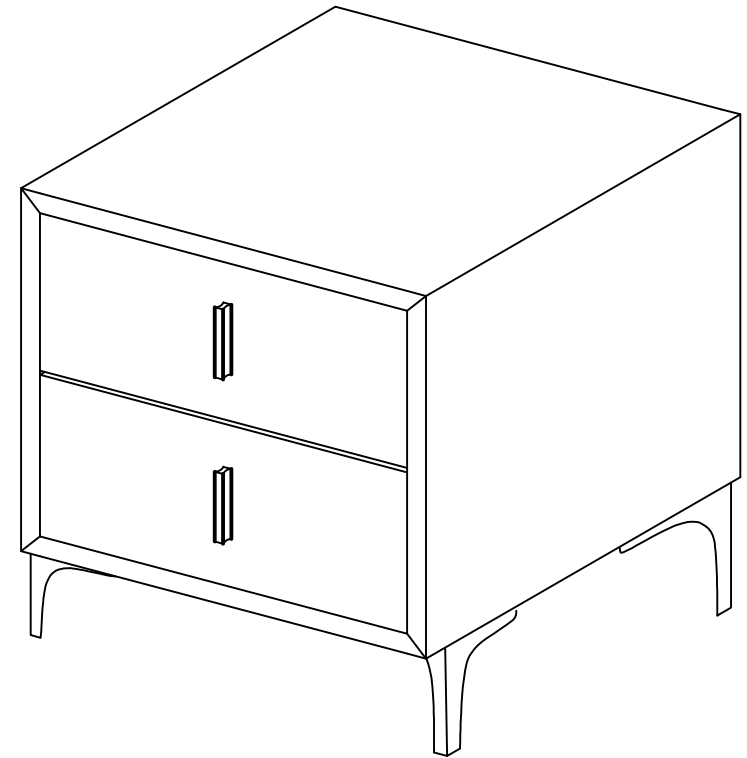





Read this instruction carefully. See hardware and furniture part list for guidance. Be sure all parts are complete, before you assemble. Place all wooden furniture parts on a clean and flat soft surface to prevent from being scratched. Follow the figure to start assembling.

CAUTIONS : 1. Do not FULLY - TIGHTEN the nut or nut bolt until all nut or bolt is ready assemble.
 2. Do not OVER - TIGHTEN the nut or bolt to avoid causing damages to the thread.
 3. Keep all hardware parts out of reach of children.

NOTE : THE LIST AND QUANTITY SHOWN ARE FOR 1 UNIT ASSEMBLY.

Tool needed : Screwdriver (not provider).

PART LIST			
ITEM	DESCRIPTION	BOX	QTY
A	BODY	1	1 PC
B	LEG	1	4 PCS
C	HANDLE	1	6 PCS
D	HANDLE SCREW	1	12 PCS
E	FLAT WASHER	1	12 PCS
F	DRAWER	1	6 PCS

HARDWARE LIST (BOX : 1)			
ITEM	DESCRIPTION		QTY
1	JCBC BOLT M6 x 20mm		8 PCS
2	M6 FLAT WASHER		8 PCS
3	M6 SPRING WASHER		8 PCS
4	M4 ALLEN KEY (BALL SHAPE)		1 PC

STEP 1

Note:

Open the last of drawer and take out all the parts.

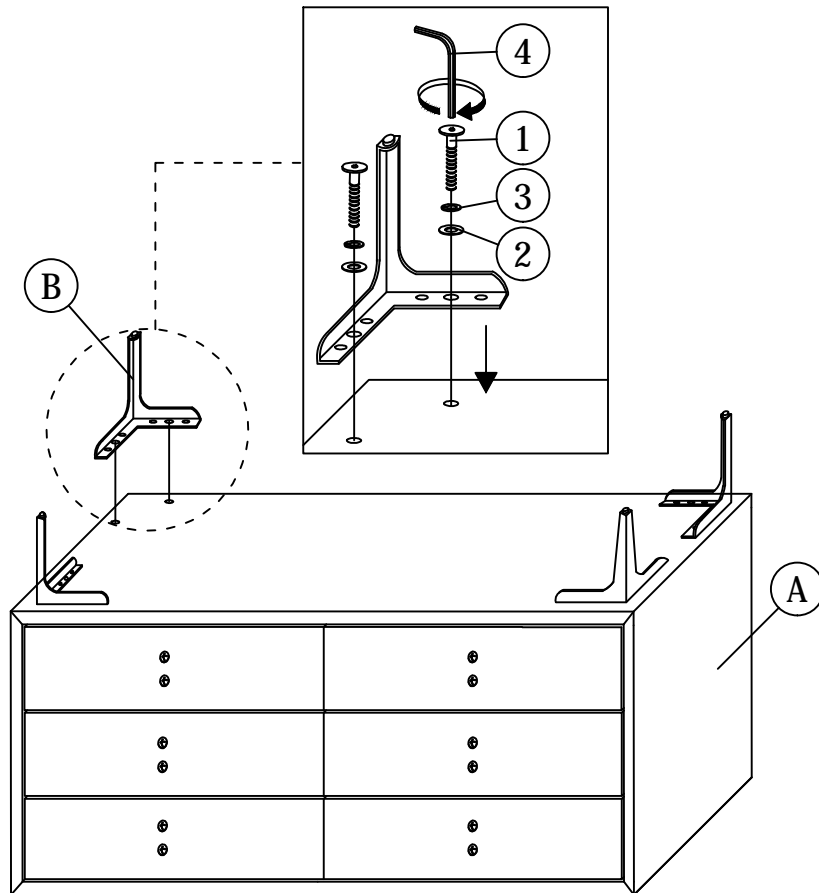

STEP 2

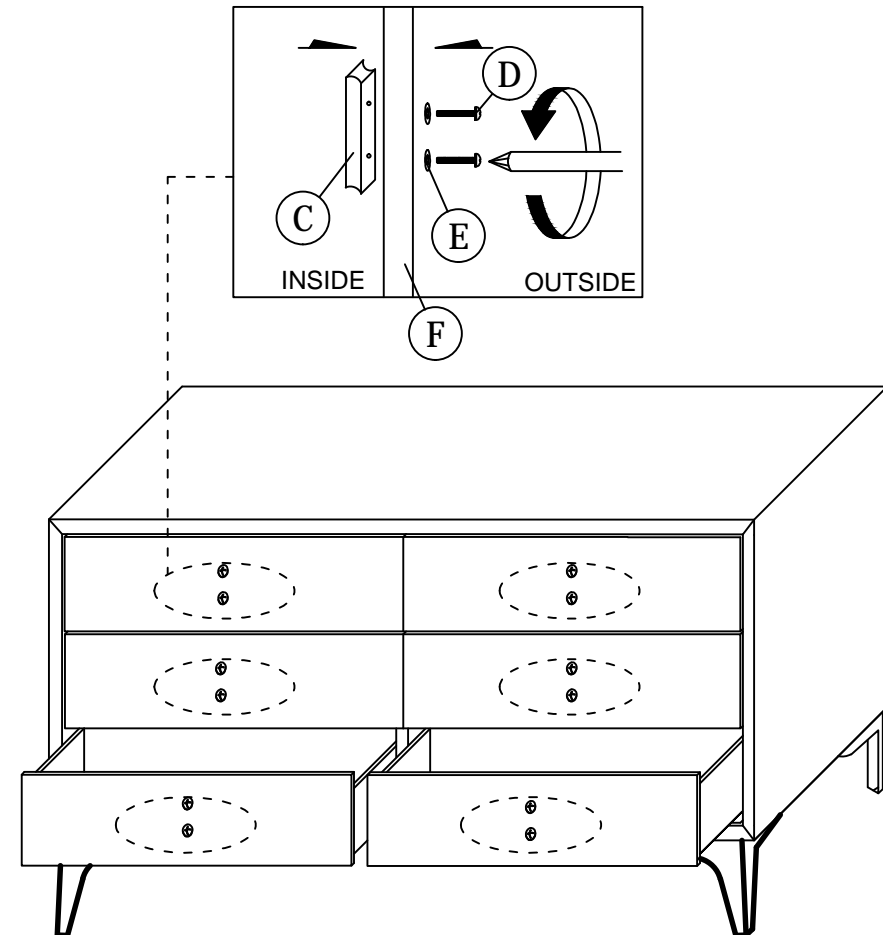

ASSEMBLY INSTRUCTIONS

2 of 2

STEP 3

Note :
Hold the handle flat and
then tighten the screws

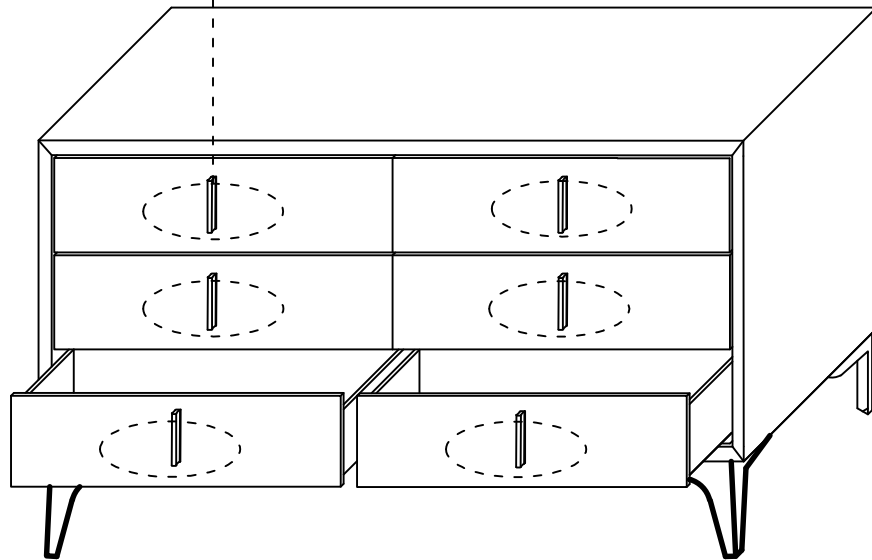
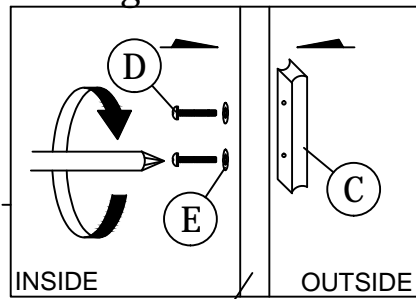

STEP 4

