



WARNING!

Children have died from furniture tipover. Fixed wall device have been included with this product;you must install the fixed wall device according to these instructions in order to minimize the risk of furniture.If you have any questions about this product or the Fixed wall device , please contact us immediately.

Never allow children to climb or hang on furniture,including drawers or cabiner doors.

In addition to installing the restrains,to help prevent tip-over.







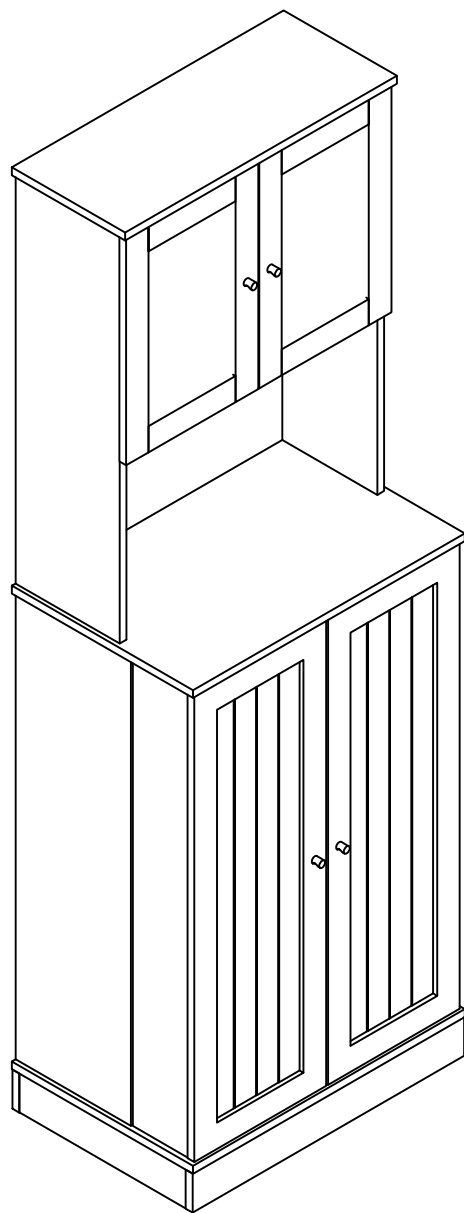

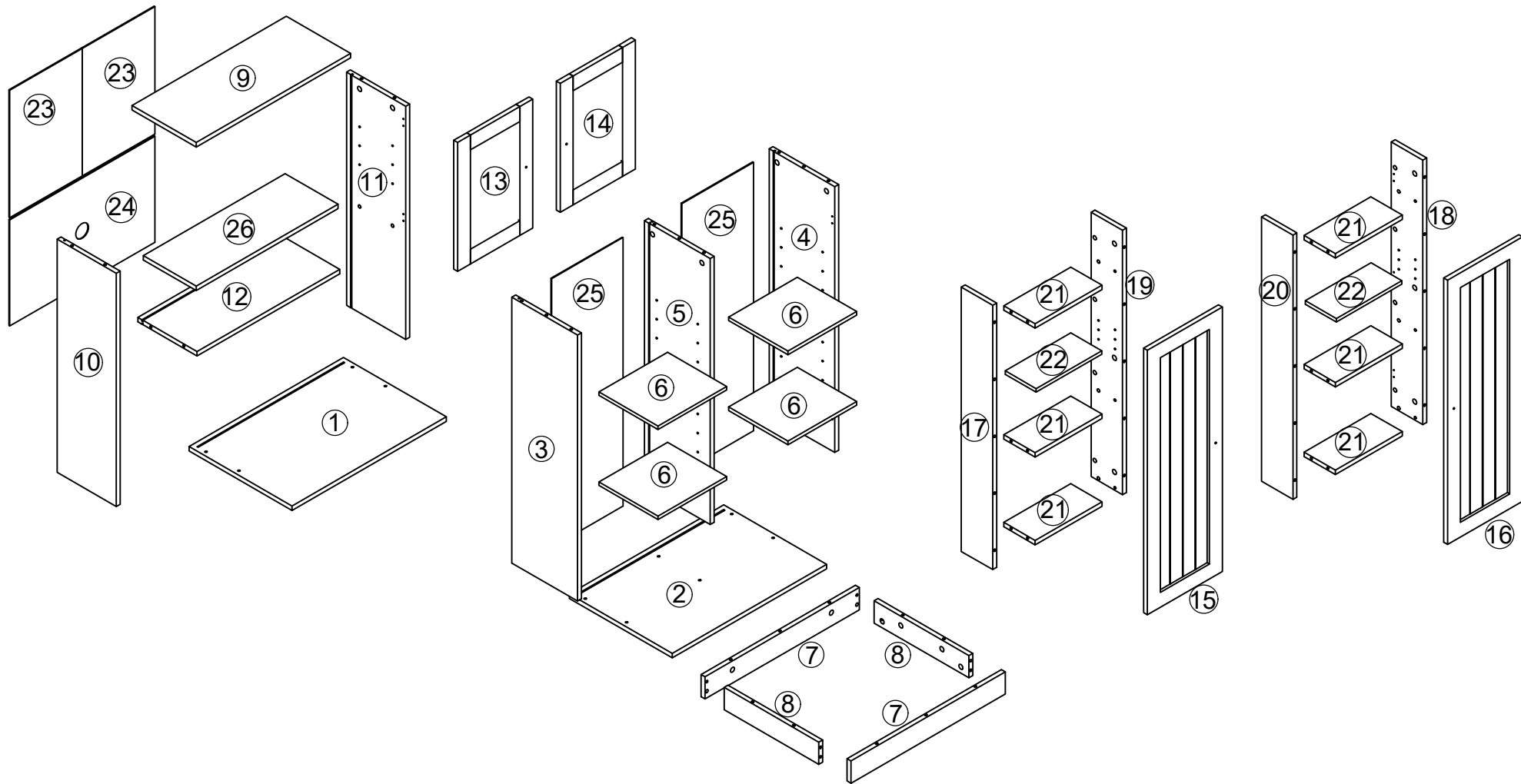

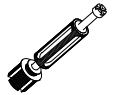

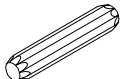
1. Never put a TV or other heavy objects on top of this product.
2. Do not stand on the product.

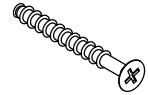
! WARNING	
	Children have died from furniture tipover. To reduce the risk of furniture tipover: <ul style="list-style-type: none">• ALWAYS install tipover restraint provided.• NEVER put a TV on this product.• NEVER allow children to stand, climb or hang on drawers, doors, or shelves.• NEVER open more than one drawer at a time.• Place heaviest items in the lowest drawers.• Do not defeat or remove the drawer interlock system. <p><i>This is a permanent label. Do not remove!</i></p>
	

DRY24009

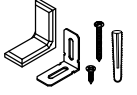
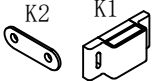



<p>A</p>  <p>50PCS</p>	<p>B</p>  <p>50PCS</p>	<p>C</p> <p>8*40</p>  <p>29PCS</p>	<p>D</p> <p>3.5*14</p>  <p>72PCS</p>	<p>E</p> <p>277mm</p>  <p>8PCS</p>	<p>F</p> <p>7*50</p>  <p>10PCS</p>	<p>G</p>  <p>6PCS</p>	<p>H</p>  <p>28PCS</p>	<p>I</p>  <p>4PCS</p>	<p>J</p>  <p>2PCS</p>
<p>K</p>  <p>4PCS</p>	<p>L</p>  <p>4PCS</p>	<p>M</p> <p>4*20</p>  <p>4PCS</p>	<p>N</p>  <p>22PCS</p>	<p>O</p> <p>3*12</p>  <p>22PCS</p>					

1

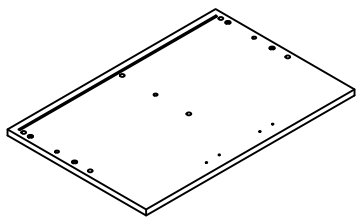

600*400 1PS

2

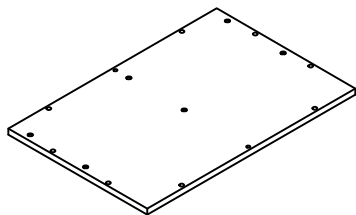

600*400 1PS

3

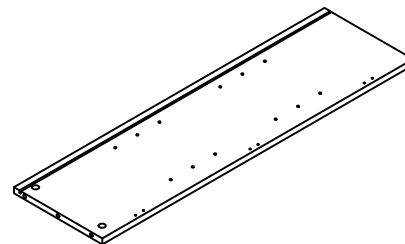

895*255 1PS

4

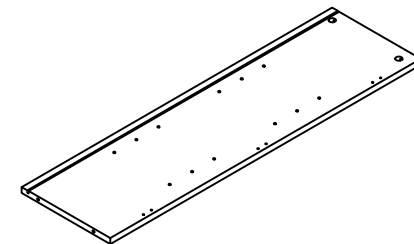

895*255 1PS

5

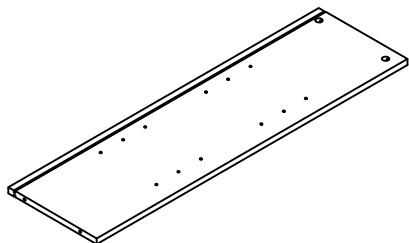

895*255 1PS

6

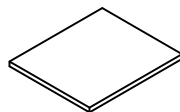

267*230 4PS

7

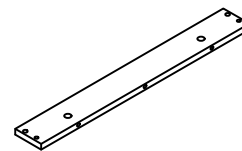

600*75 2PS

8

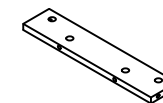

368*75 2PS

9

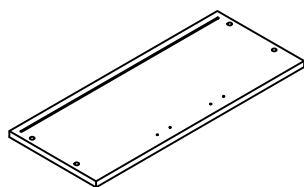

600*250 1PS

10

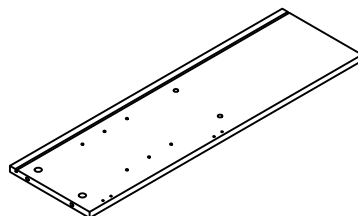

785*230 1PS

11

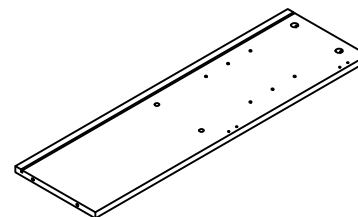

785*230 1PS

12

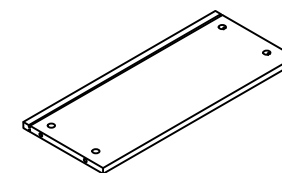

554*230 1PS

13

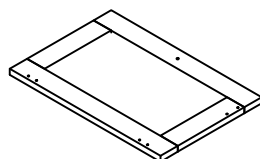

434*292 1PS

14

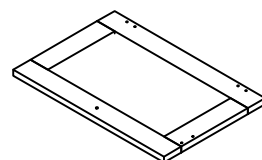

434*292 1PS

15

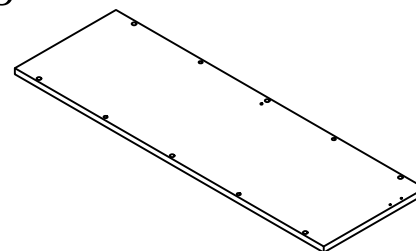

890*291 1PS

16

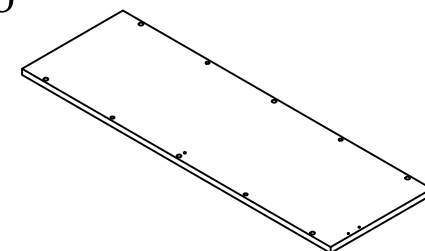

890*291 1PS

17

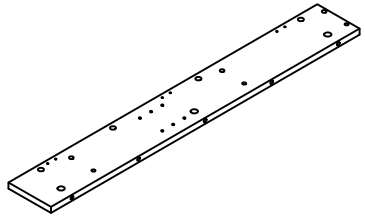

890*122 1PS

18

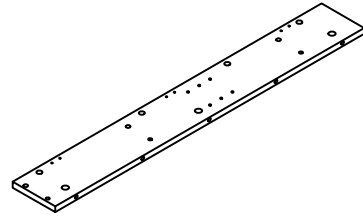

890*122 1PS

19

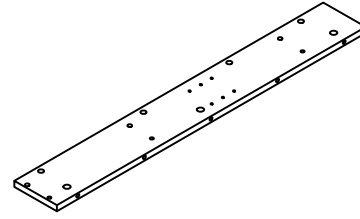

890*122 1PS

20

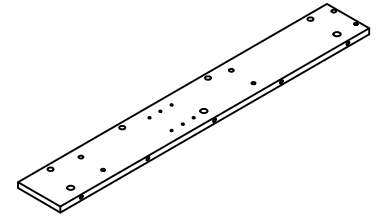

890*122 1PS

21

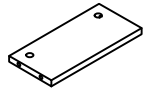

259*122 6PS

22

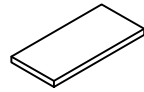

254*120 2PS

23

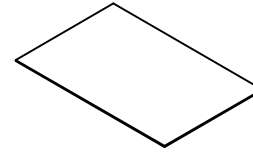

429*282 2PS

24

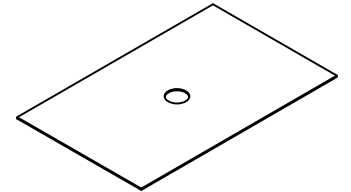

357*564 1PS

25

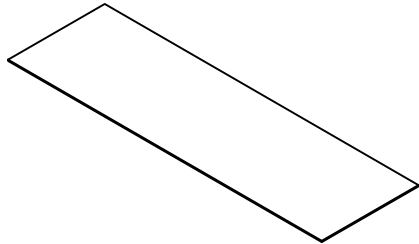

904*278 2PS

26

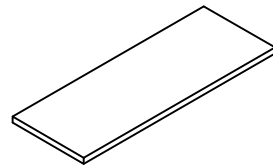

551*205 1PS



Hardware installation demonstration

NOTE: Please make sure "A" hardware tightened and can't be pulled out!

I

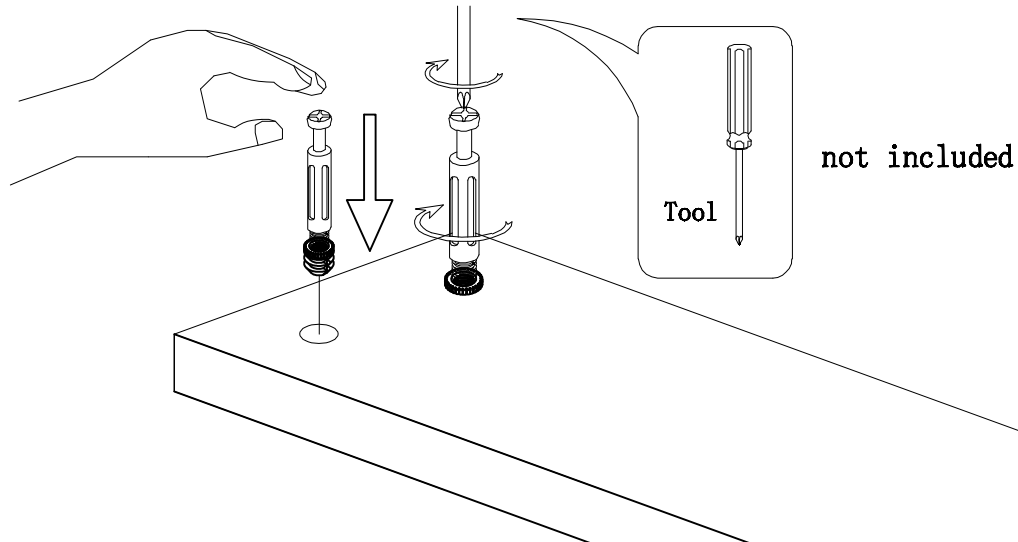

II

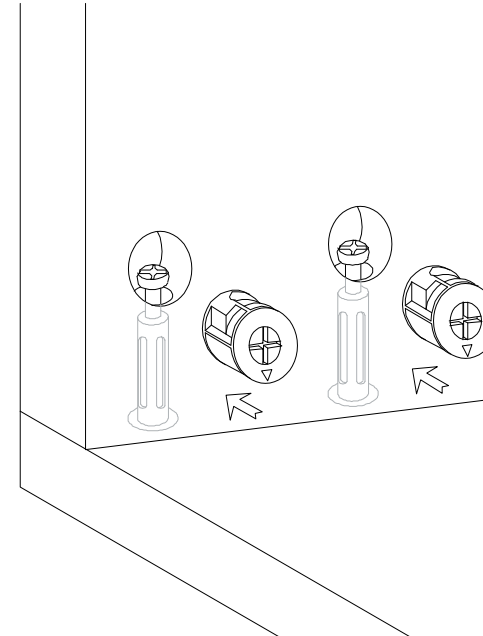

III

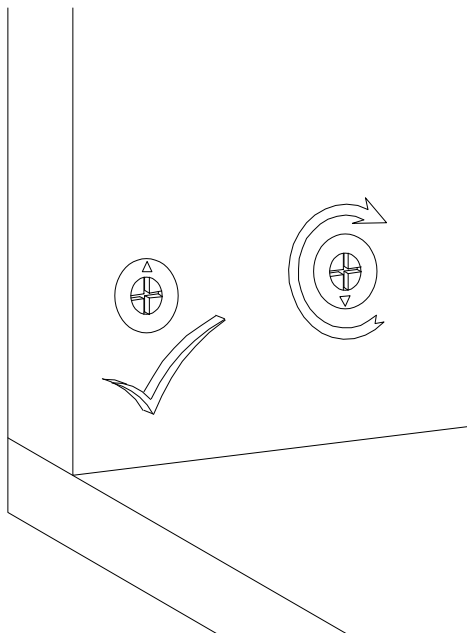





IV

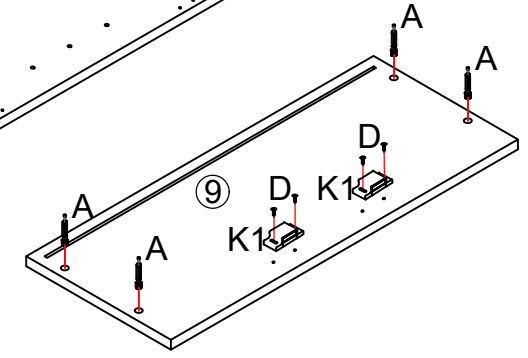
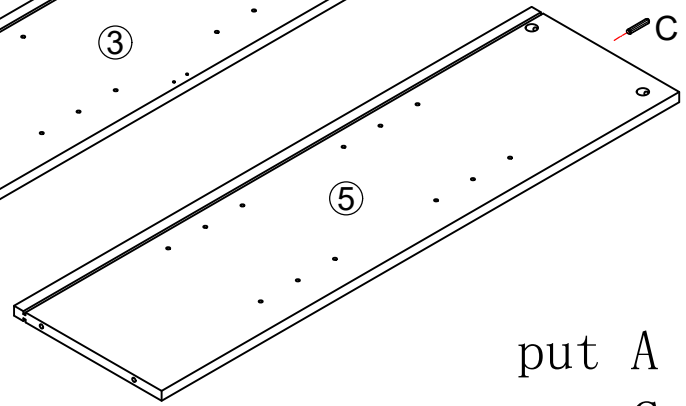
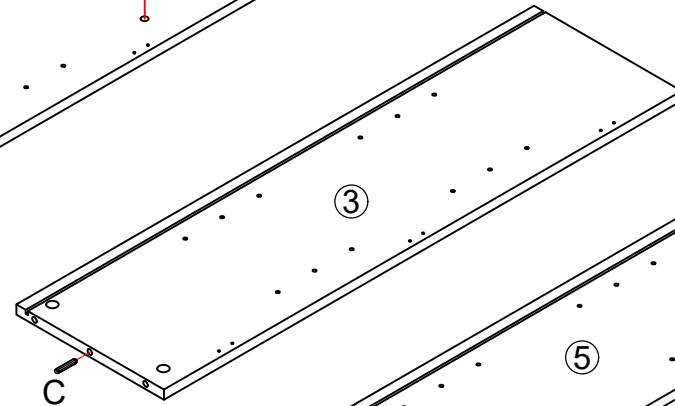
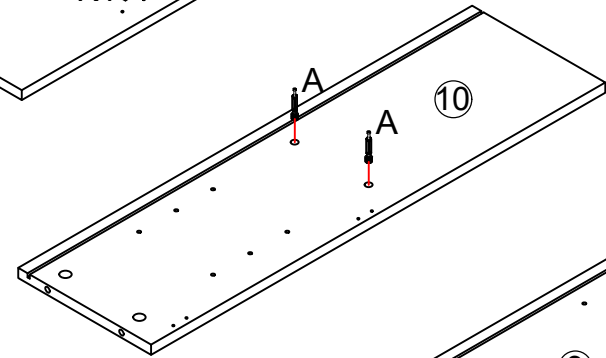
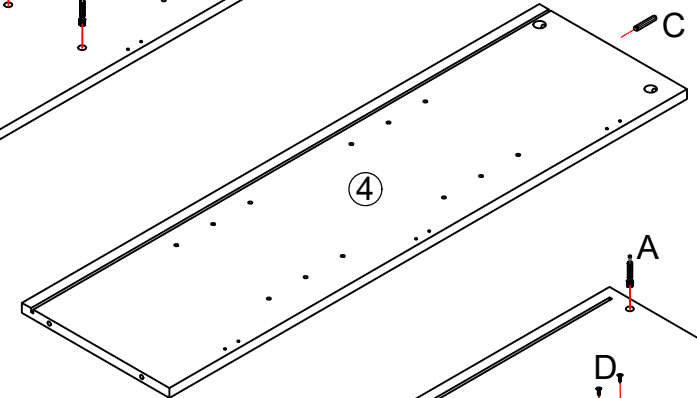
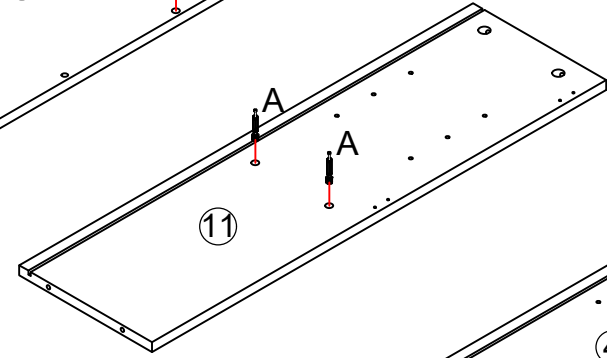
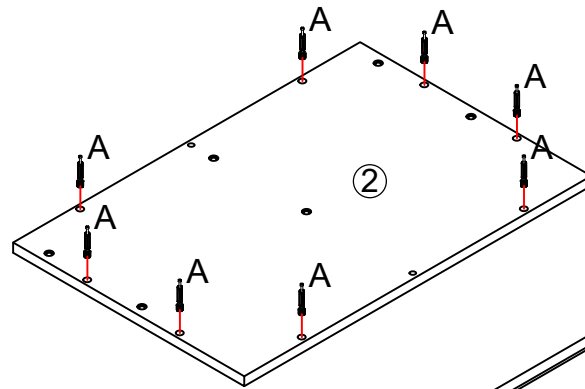
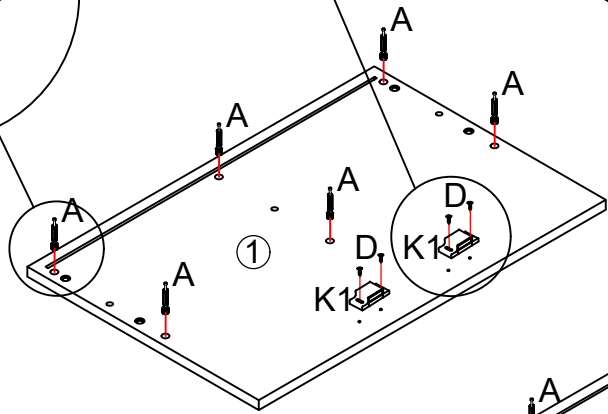
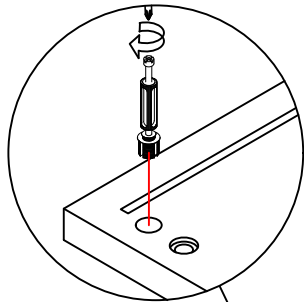
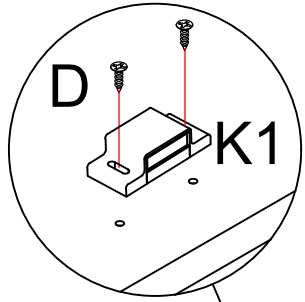

Scan QR code for assembly video

1

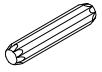



	A*22
	C*3
	D*8
	K1*4

put A on board ① ② ⑨ ⑩ ⑪
 put C on board ③ ④ ⑤

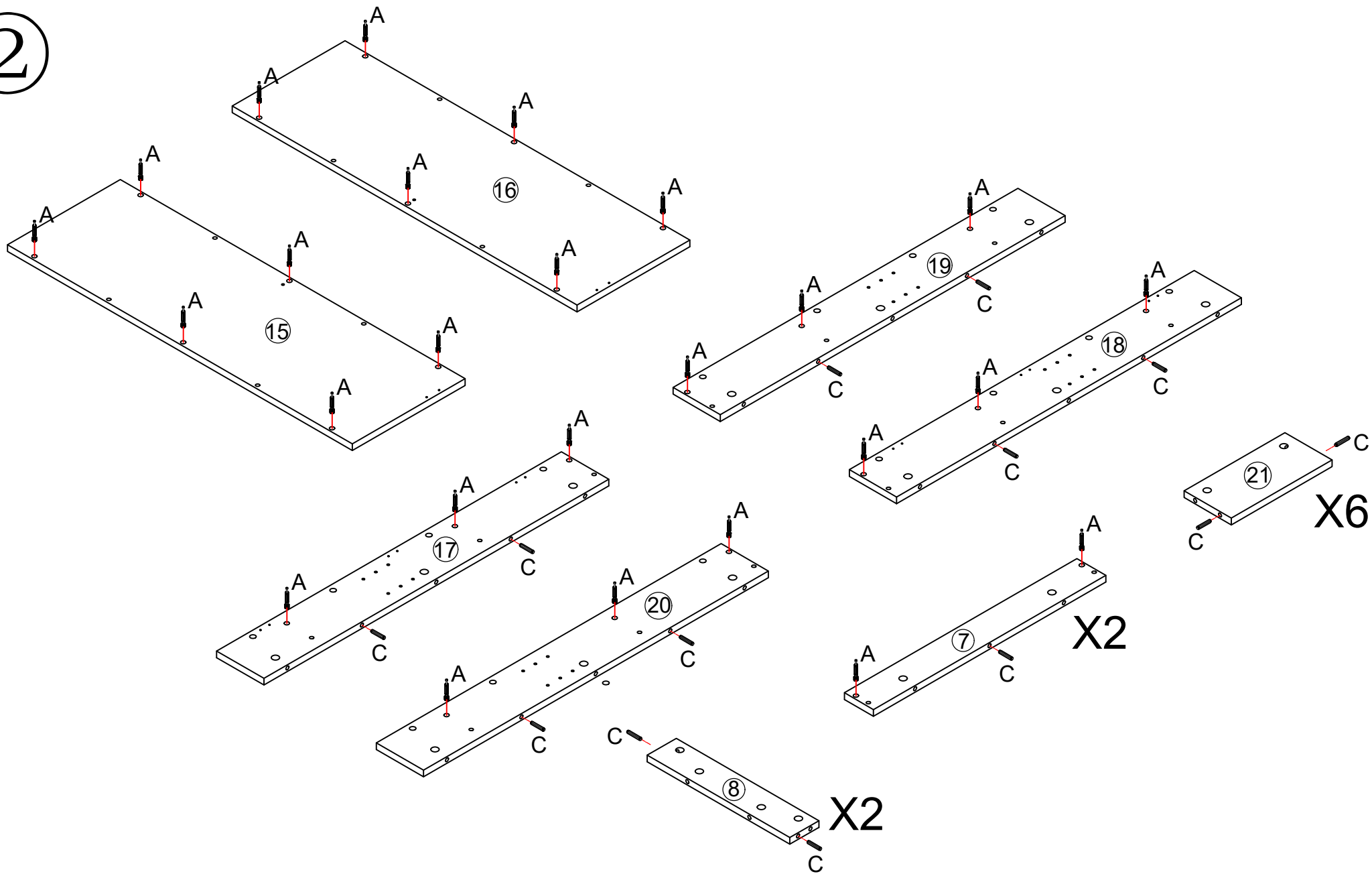
2



	A*28
	C*26

put A on board ⑦ ⑮ ⑯ ⑰ ⑱ ⑳

put C on board ⑦ ⑧ ⑰ ⑱ ㉑

3

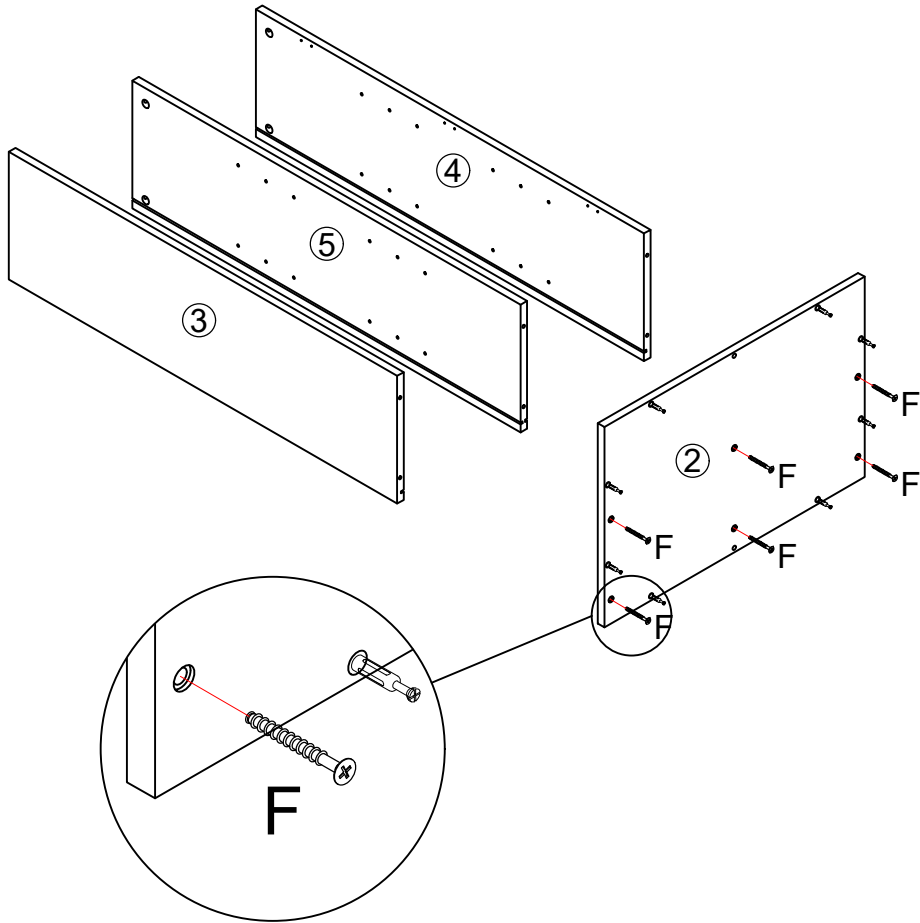

Make sure the arrow on the screw align to the hole on the side.

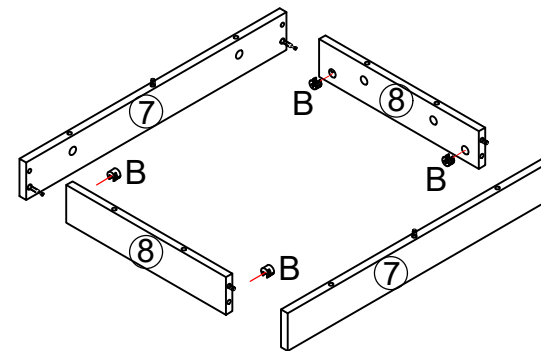
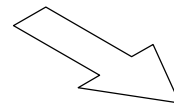
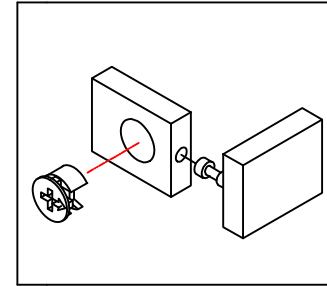

B*4



F*6

4

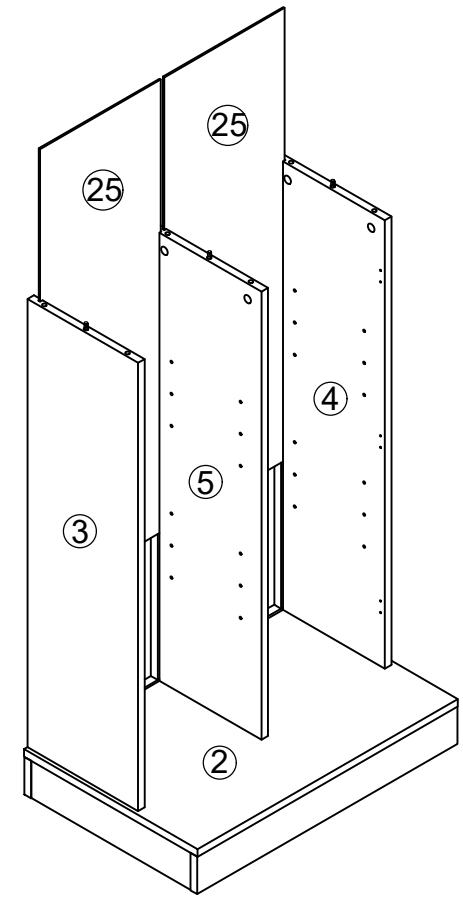
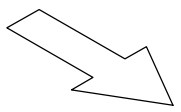
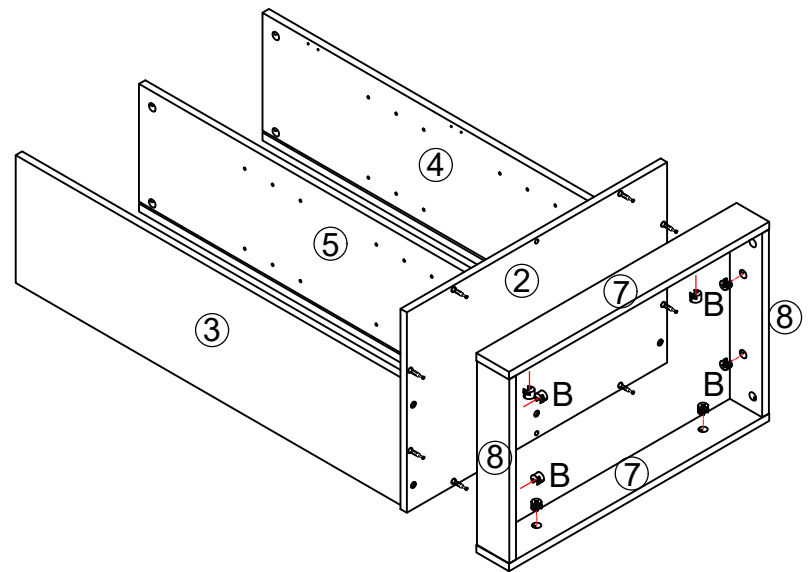

B*8

5

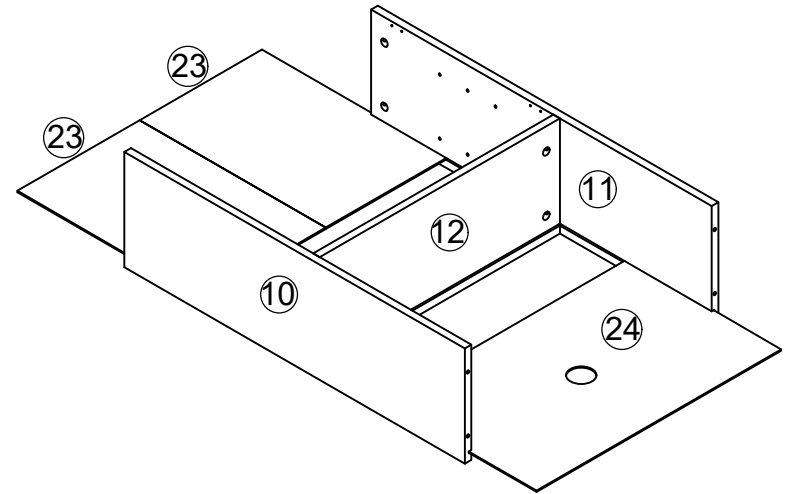
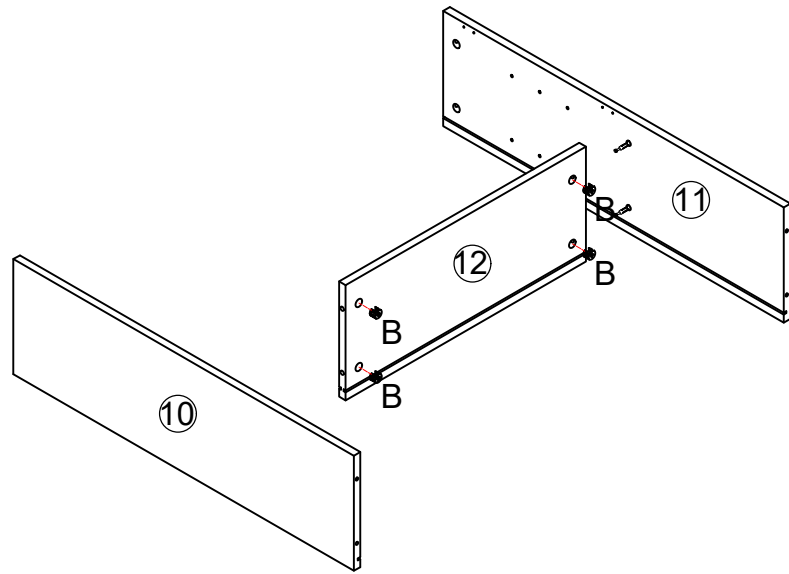

B*4

6

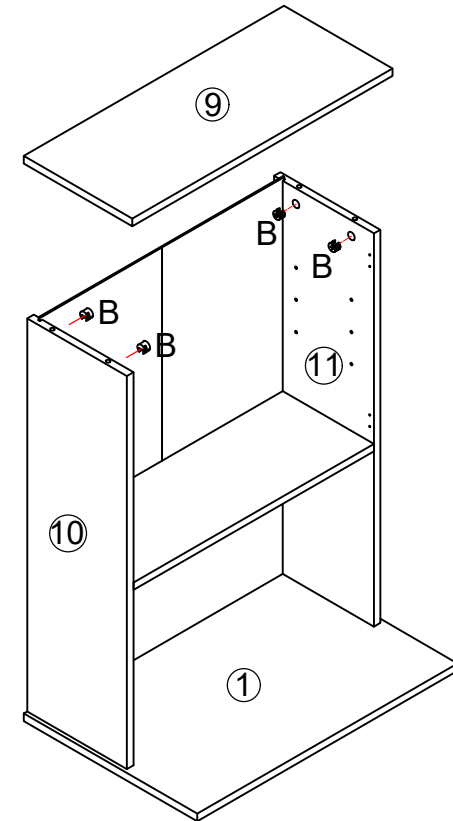
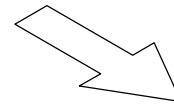
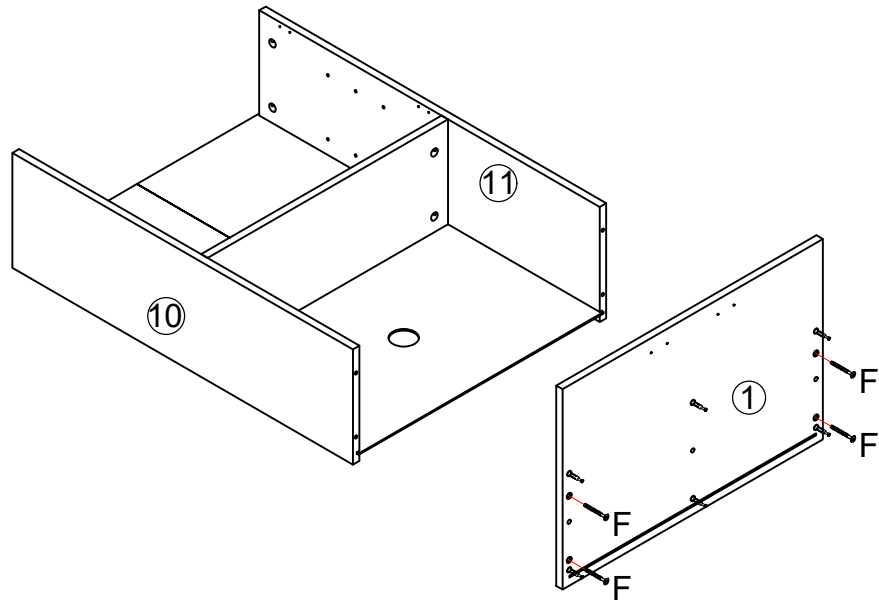

B*4



F*4

7

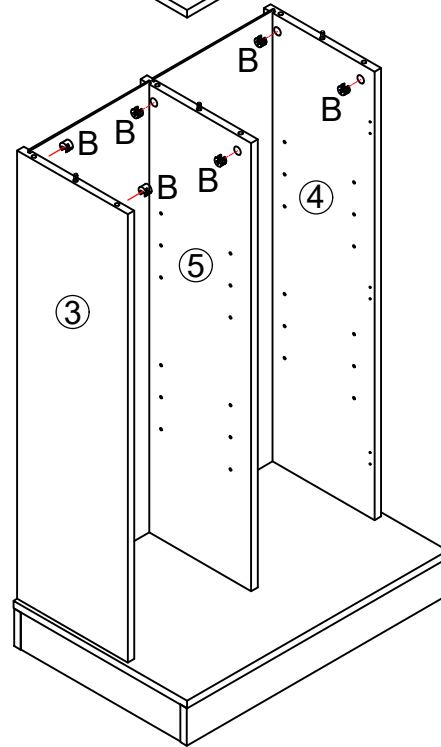
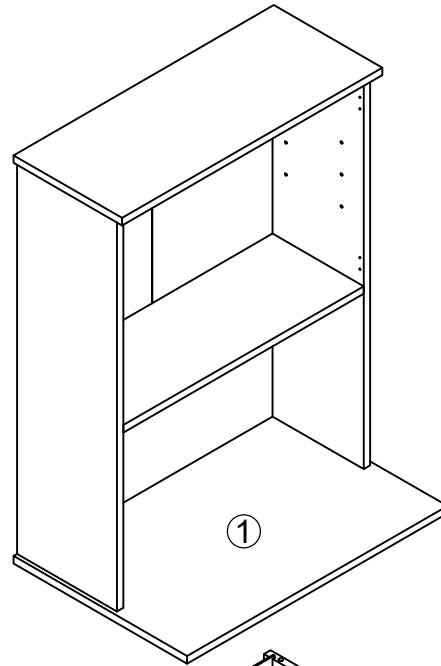

B*6

8

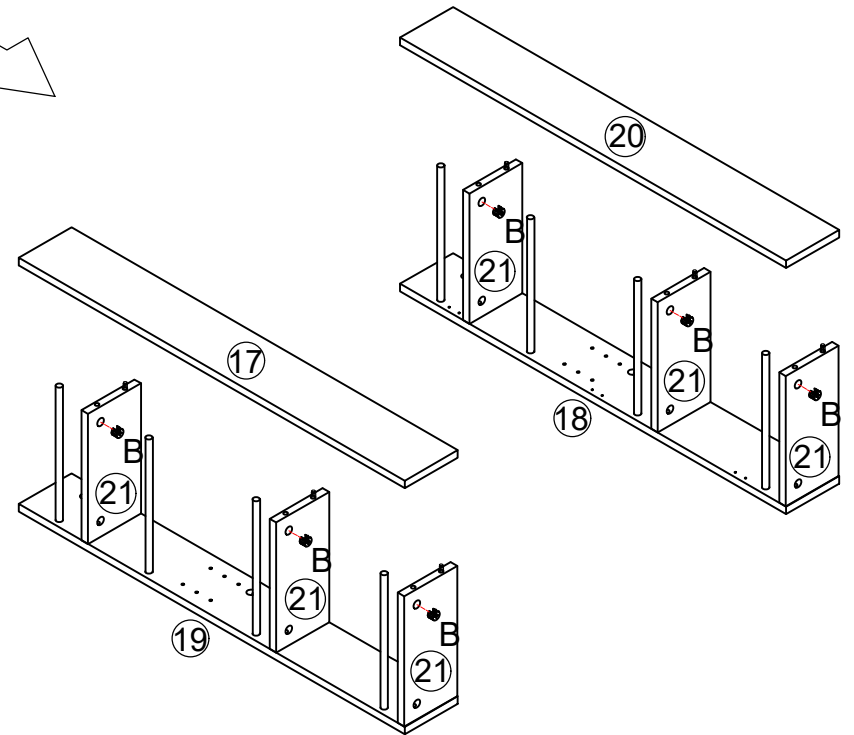
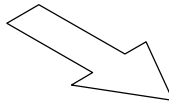
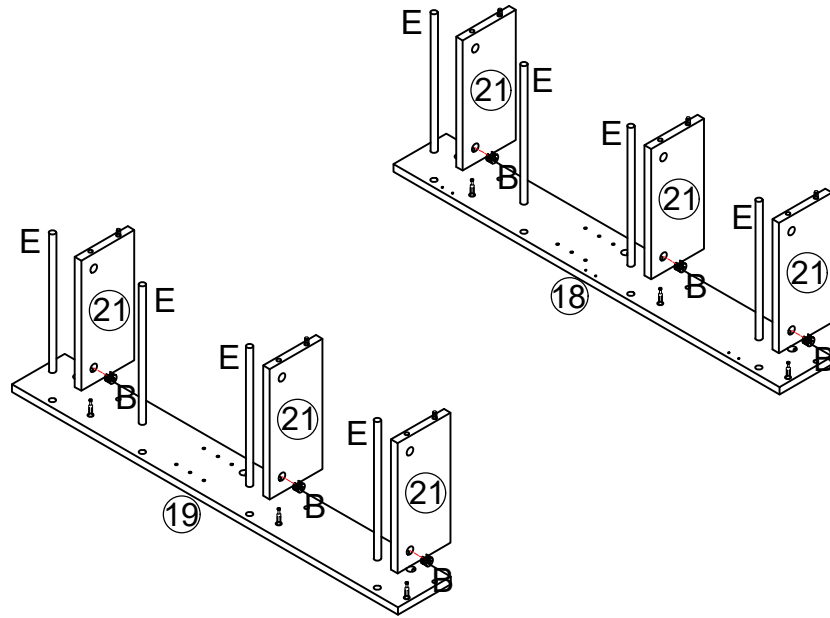

B*12



E*8

9

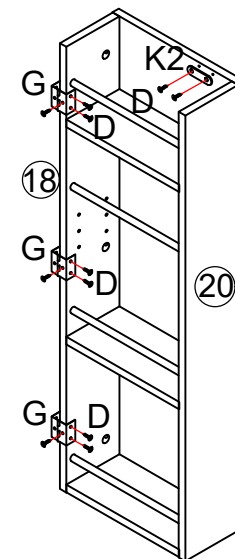
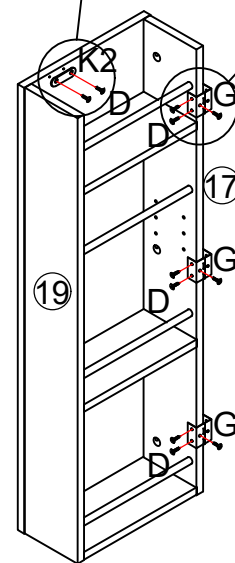
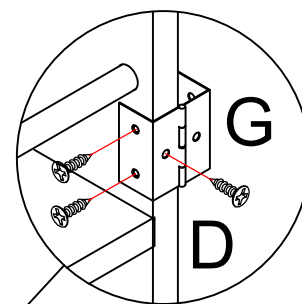
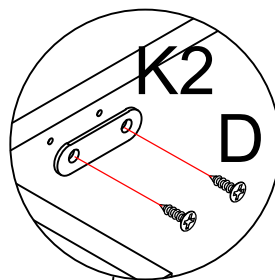
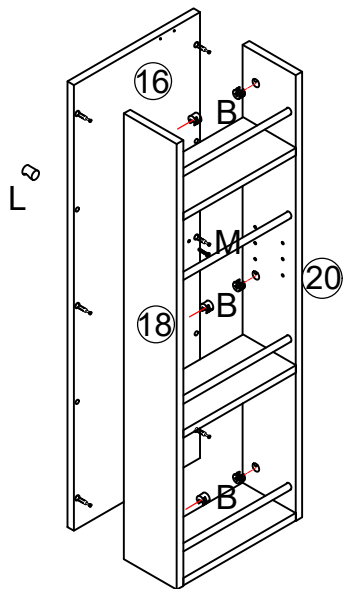
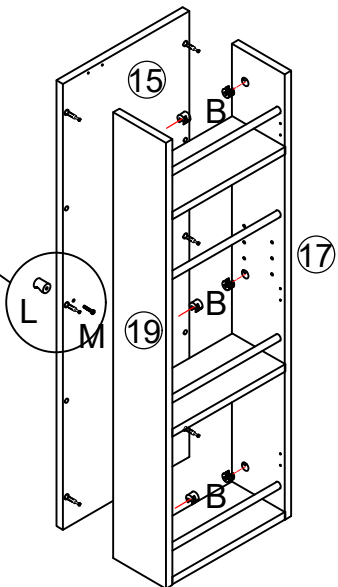
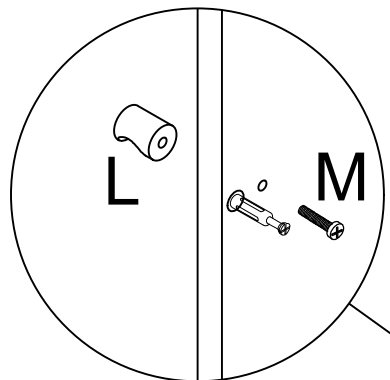

B*12



D*22



K2*2



G*6



L*2



M*2

10

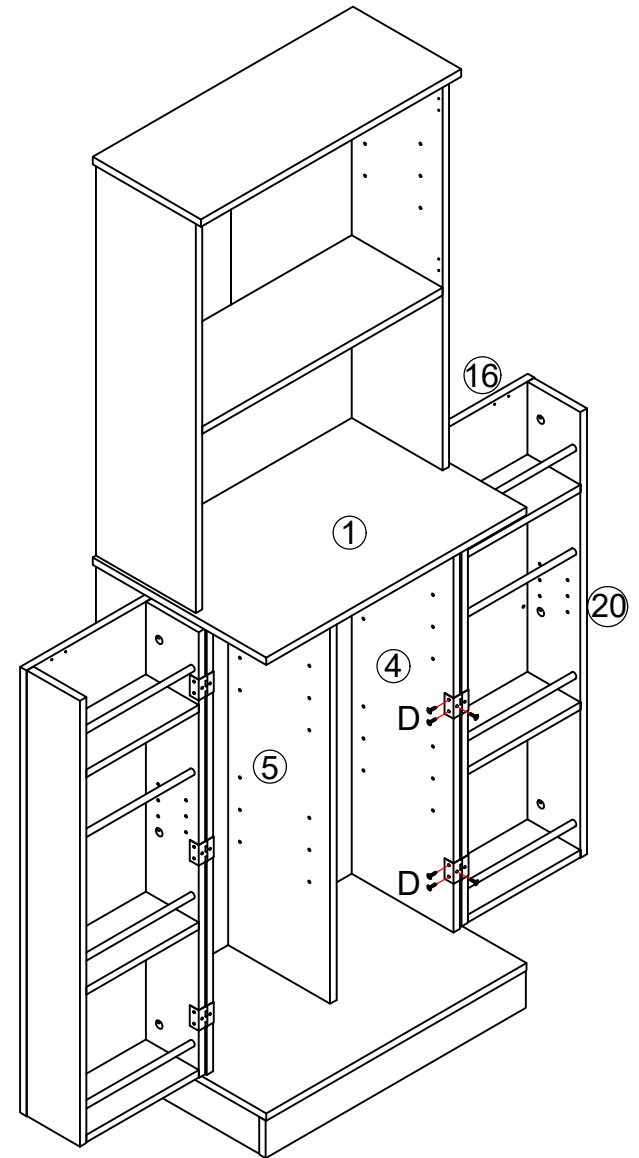
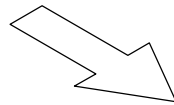
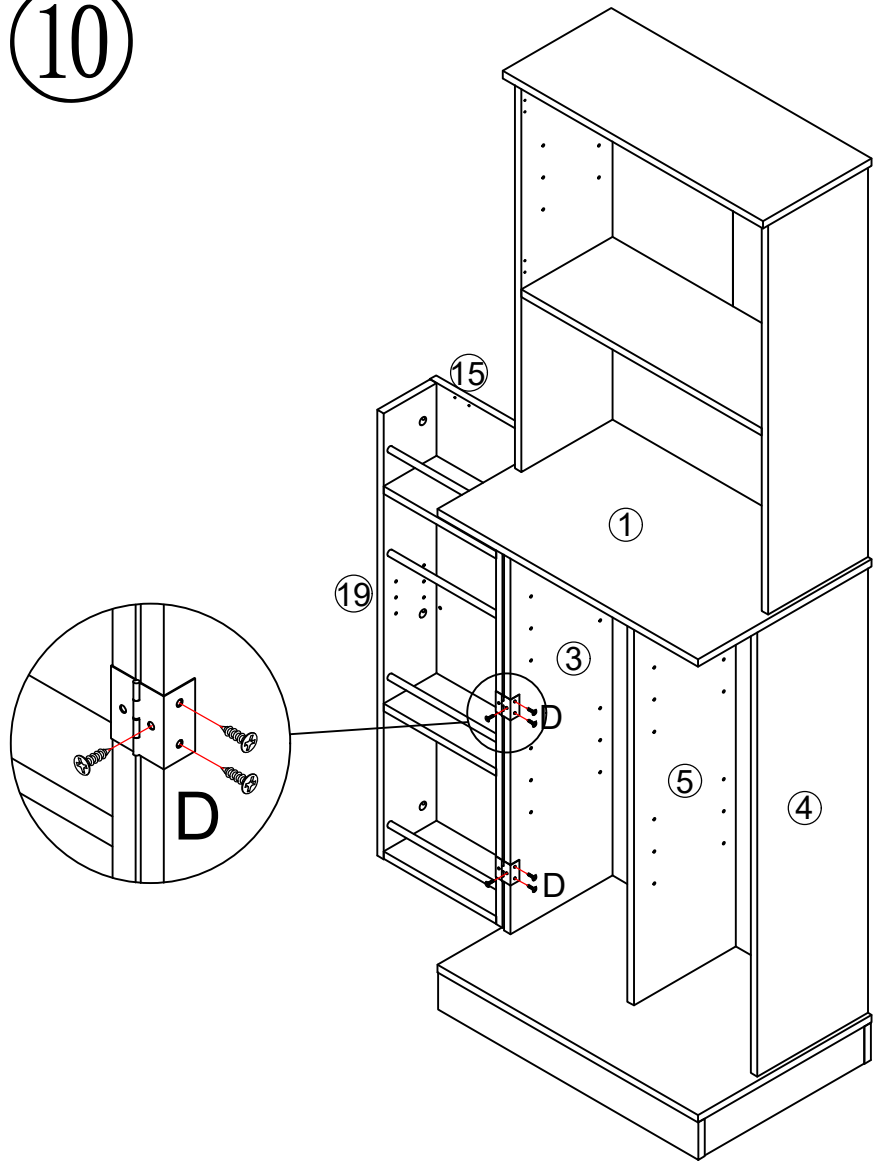

D*18



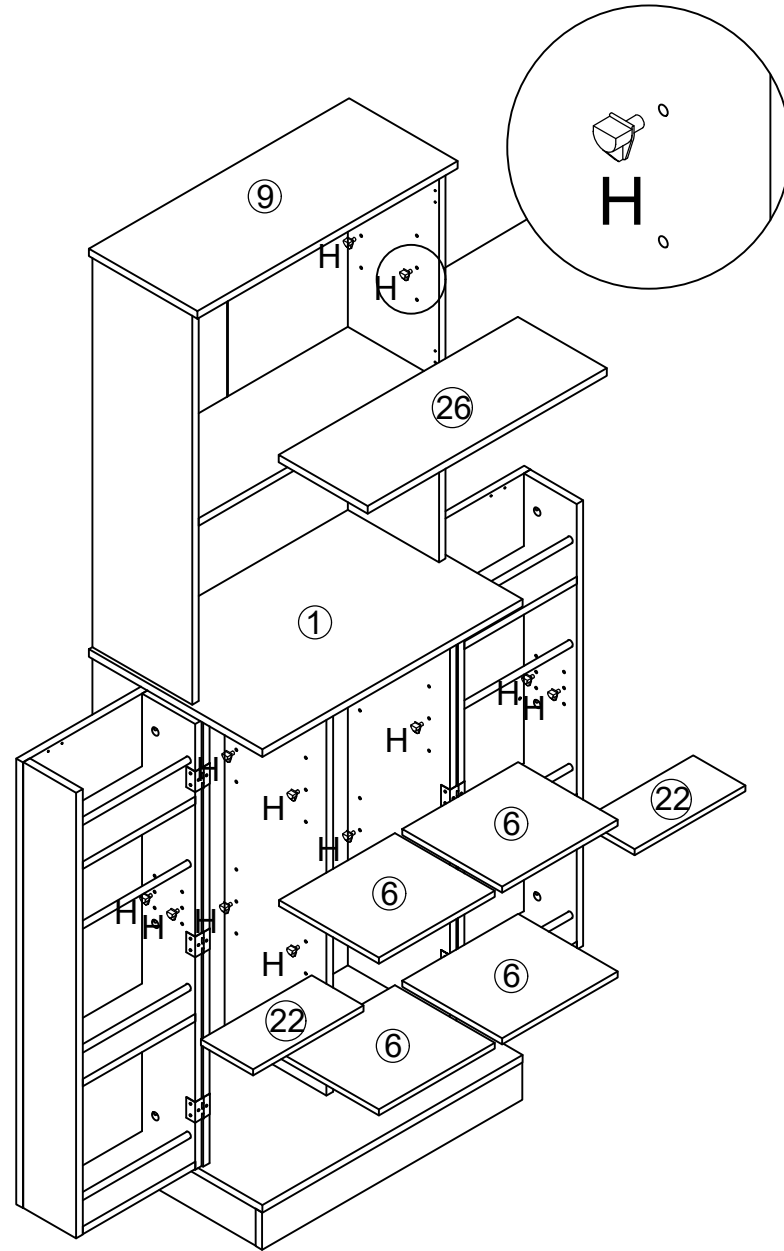

11

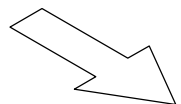
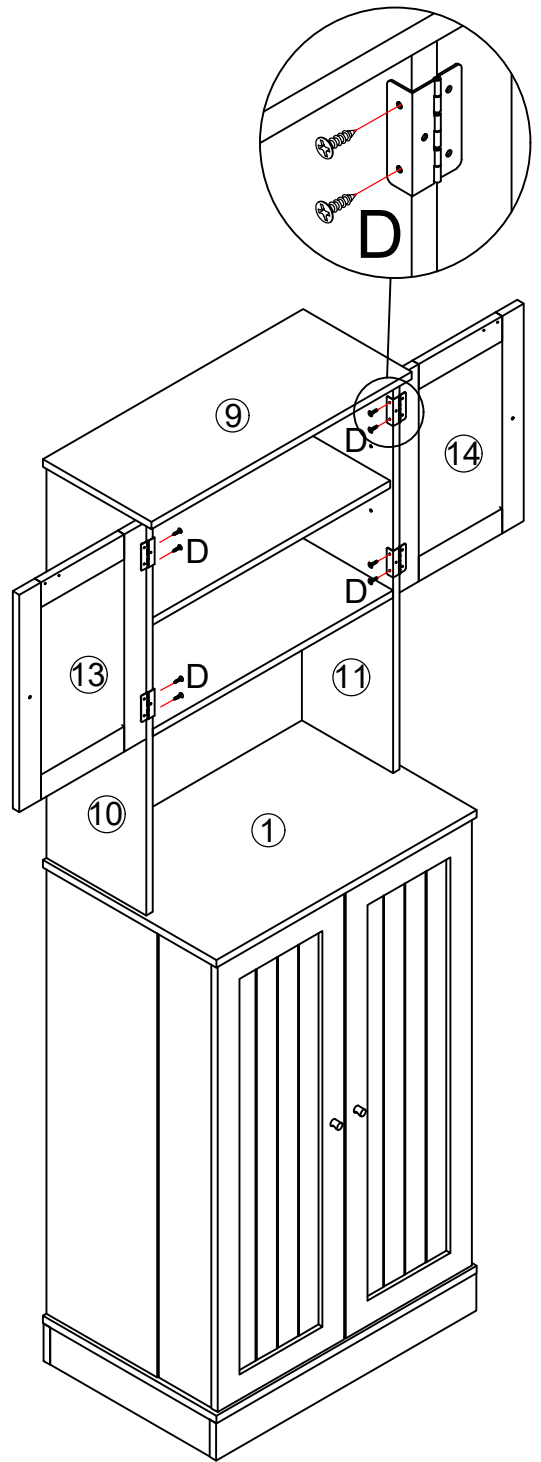
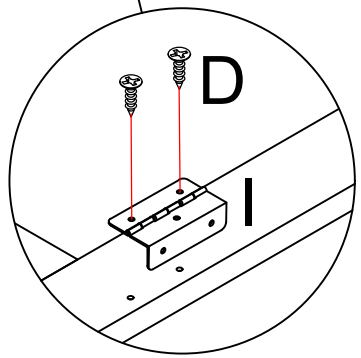
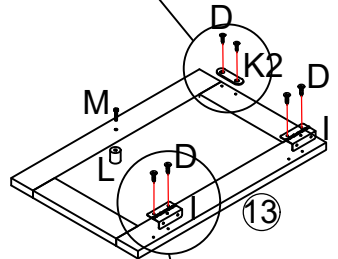
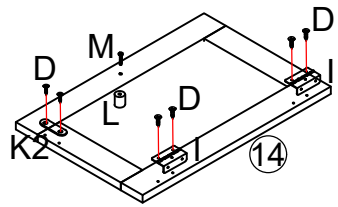
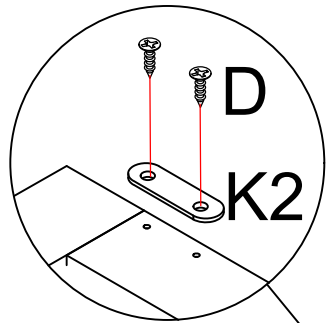

H*28

12



	D*24
	K2*2
	L*2
	M*2
	I*4

13

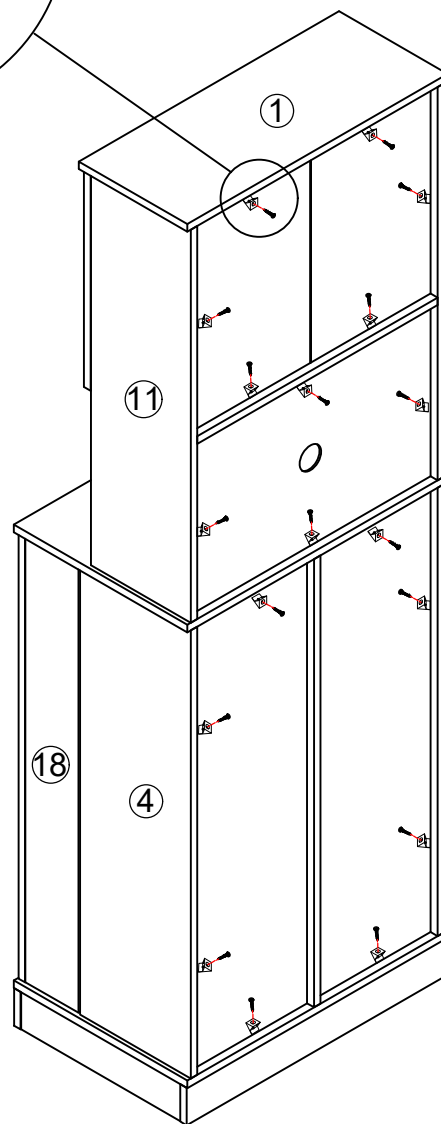
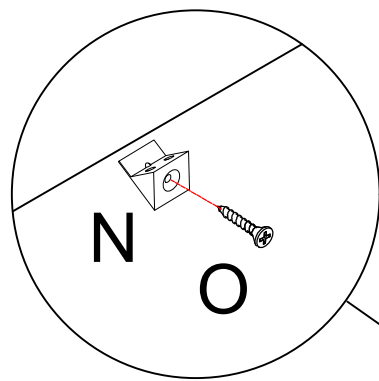

N*18



O*18

14

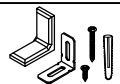
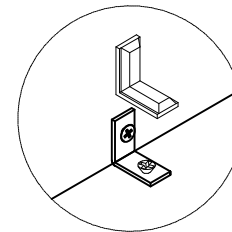
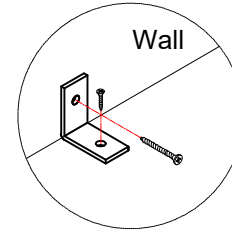
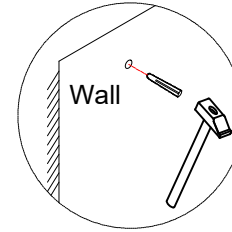
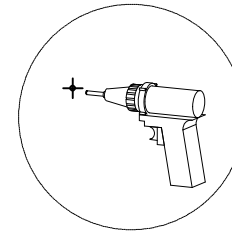
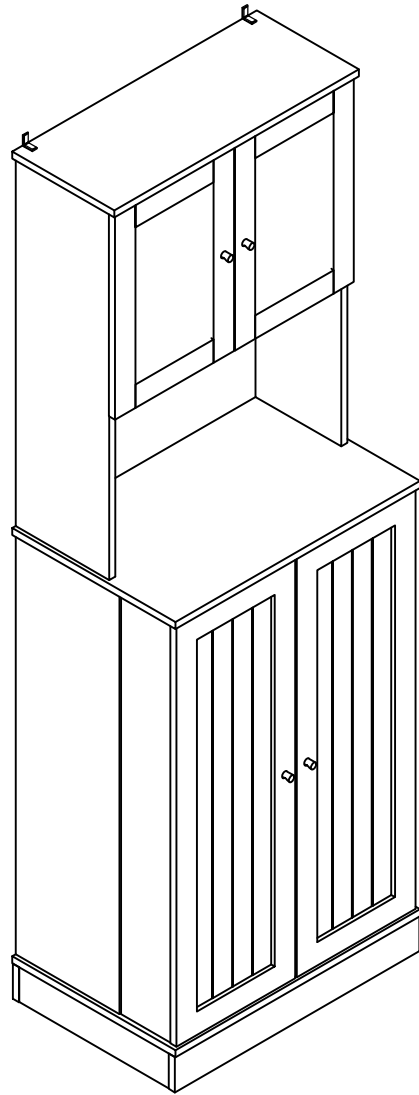

J*2

Please install tip-proof fitting.