

PLEASE READ THE INSTRUCTIONS

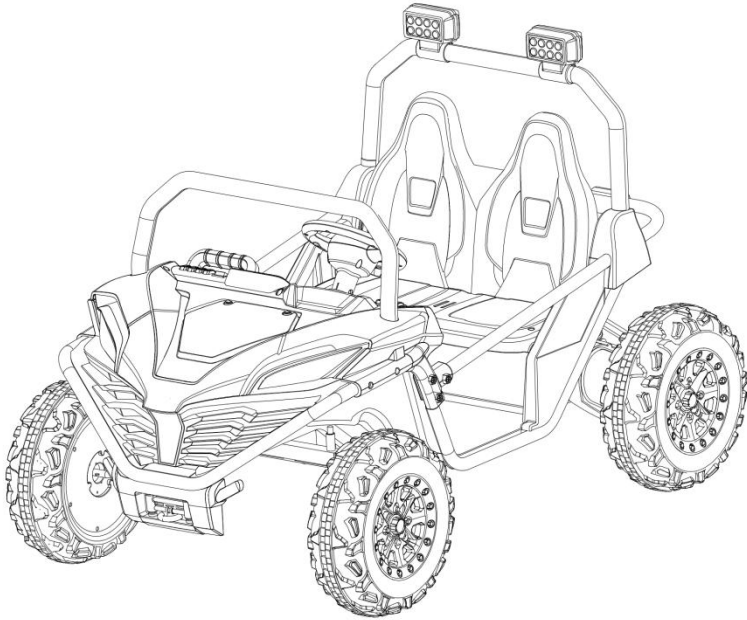

Styles and colors may vary

◎ Suitable age for 3-8 Years

◎ Maximum user weight: 59kg

◎ Adult assembly required

USER MANUAL

AFTER SALES SUPPORT :

1. We will provide the free parts within 1 years.
2. If there are any problems of the product, please contact us, our professional team will deal with and help you to solve the problem ASAP!

Contact info

1. Email: YMN-1@outlook.com
2. Amazon:
 - 1). Visit www.amazon.com/your-orders
 - 2). Find your product
 - 3). Click on “contact seller”
 - 4). Include your order #



Charge for 4-6 hrs
before initial use.

After initial charge,
follow the normal
recommended
Charging time.



SAFETY

Please retain these instructions for future reference.

NOTE:For best performance,only use this vehicle on flat and hard surfaces.

AGE RANGE:3 to 8 years old

WEIGHT CAPACITY:59KG is the maximum weight for 2 riders(combined)

The following safety hazards may result in serious injury or death:

- This product contains small parts.Keep children away during assembly.Make sure to remove all packaging material and parts from underneath the vehicle body.
- Never open the battery.Batteries contain lead and lead compounds(acids).
- Limbs,hair,and clothing can get caught in moving parts.Always wear shoes,keep limbs away from moving parts,and do not wear loose clothing while operating this vehicle.
- This vehicle does not have brakes or braking capability.Do not leave a child unattended during operation.DO not use this in a location that may require braking capability.as this could result in loss of control,which may cause serious injury or death.
- Use of this vehicle near streets,motor vehicles,steps,bodies of water,sloped surfaces,hills,wet areas,flammable vapors,in alleys,at night,or in the dark could result in an unexpected accident.
- Use of this vehicle in unsafe conditions such as snow,rain,loose dirt,mud.sand,or gravel may result in an unexpected accident such as tipping over,and could damage the electrical system or battery.
- Do not operate this vehicle in an unsafe manner.Examples include but are not limited to:
 - pulling the vehicle with another vehicle or similar device
 - Allowing more than two children to ride
 - Pushing the user
 - Traveling at an unsafe speed

BATTERY WARNINGS

The following safety hazards may result in serious injury or death:

- Use of a battery or charger other than the supplied rechargeable battery and charger may cause a fire or explosion. Only use the supplied battery and charger.
- Use of the rechargeable battery and charger for any other product may result in overheating, fire, or explosion. Never use the supplied rechargeable battery and charger with another product.
- Explosive gases are created during charging. Charge the battery in a well-ventilated area. Do not charge the battery near heat or flammable materials.
- Contact between the positive and negative terminals may result in fire or explosion. Avoid direct contact between the terminals. Picking up the battery by the wires or charger can cause damage to the battery and may result in a fire. Always pick up the battery by its case or handles.
- Liquids on the battery may cause fire or electric shock. Always keep all liquids away from the battery and keep the battery dry. Contact or exposure to battery leakage (lead acid) may cause serious injury. If contact or exposure occurs immediately call your physician. If the chemical is on the skin or in the eyes, flush with cool water for 15 minutes. If the chemical was swallowed, immediately give the person water or milk. Do not give water or milk if the patient is vomiting or has a decreased level of alertness. Do not induce vomiting.
- Battery posts, terminals, and related accessories contain lead and lead compounds (acid)
- Tampering or modifying the electric circuit system may cause a shock, fire or explosion and permanently damage the system. Exposed wiring and circuitry in the charger may cause electric shock. Always keep the charger housing closed.

USER WARNINGS

The following safety hazards may result in serious injury or death:

- Never leave a child unattended.
- Always sit in the seat when using this vehicle.
- Keep your hands, hair, and clothes away from moving parts.
- Always wear shoes when operating this vehicle.
- Maximum of two children are allowed in the vehicle at a time.
- Children under 3 years of age cannot use the vehicle.
- Only drive on level ground.
- Do not go near swimming pools or other bodies of water, drop-offs, or up and down steep inclines.
- Do not drive the vehicle into loose dirt, mud, sand, fine gravel, or on wet surfaces.
- Do not drive the vehicle on streets or near cars.

SPECIFICATIONS

Item	Specification
Batteries	24V
Motor	24V
Age	3-8years
Max Weight	59KG
Dimension	121*80.5*80CM
Speed	2.5-7.5-km/hr
Play Time	1-2 hours / recharger time 8-12hours
Charger	Output DC 24V

TOOLS REQUIRED



SCREWDRIVER
(BRING YOUR OWN)



M10 WRENCH
(PROVIDED)



M10 IRON WRENCH
(PROVIDED)



2 PERSON
ASSEMBLY



APPROXIMATELY
45 MIN.
ASSEMBLY

HARDWARE

1

M4*12mm
SCREW



2 PCS

2

ϕ 12 WASHER



6 PCS

3

M10 NUTS



6 PCS

4

COTTER PIN



2 PCS

5

ϕ 8 GASKET



2 PCS

6

SCREW

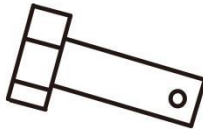

2 PCS

7

ϕ 10 WASHER



2 PCS

8

SPRING



2 PCS

PARTS

A

FRONT WHEEL



2 PCS

B

REAR WHEEL



2 PCS

C

WHEEL COVER

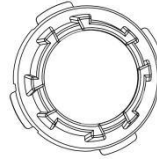

4 PCS

D

STEERING WHEEL



1 PCS

E

FRONT BLOCK

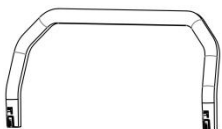

1 PCS

F

SEARCHLIGHT

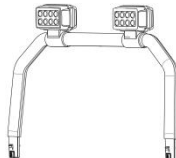

1 PCS

G

SEAT

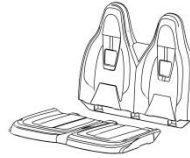

1 SET

H

REAR BUMPER
DECORATION



4 PCS

I

SPRING SLEEVE



2 SET

J

GEAR BOX (L/R)

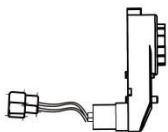

2 PCS

K

REMOTE CONTROL



1 PCS

L

CHARGERS



1 PCS

MDUAL DRIVE
FRONT BRACKET

1 PCS

N

REAR AXLE



1 PCS

O

TORSION BAR



2 PCS

P

PRODUCT ASSEMBLY

M **I** **8**

Fix the dual drive front bracket

- Insert spring and spring sleeve into the dual drive front bracket.
- Insert the dual drive front bracket into the body square tube.

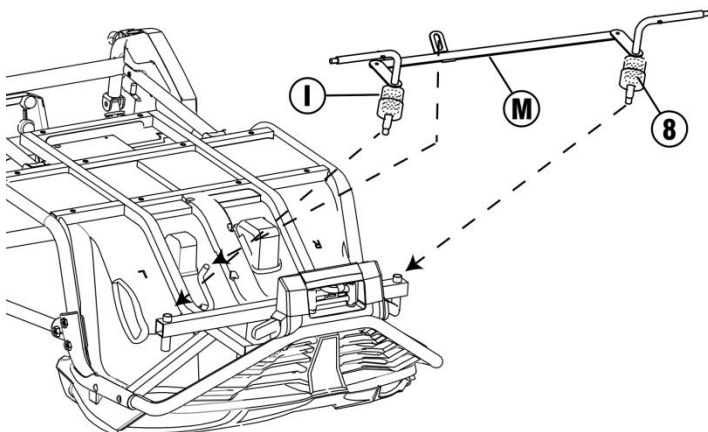

PRODUCT ASSEMBLY

③ ⑦ Fix the dual drive front bracket.

- In turn put the $\phi 10$ washer and nut into the dual drive front bracket.
- Fix the nut with the M10 iron wrench.

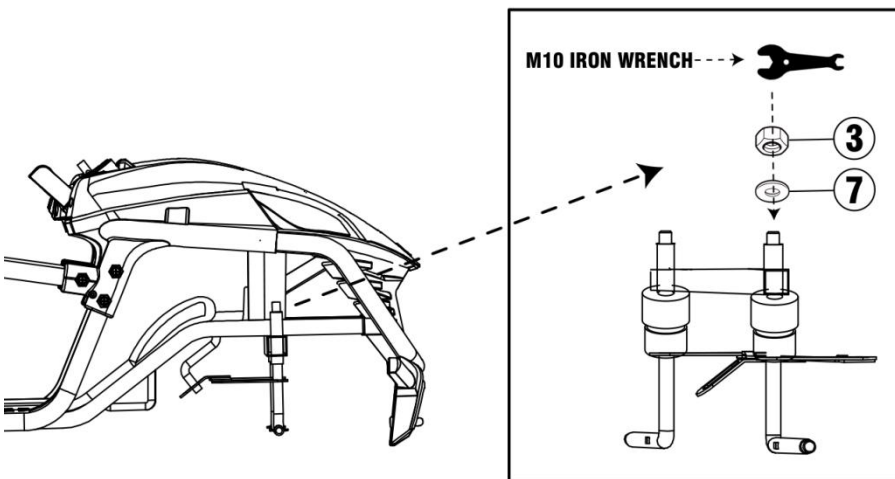

① ④ ⑤ ⑥ Fix the torsion bar.

- Turn the torsion bar so that the hole of the torsion is aligned the hole of the rear axle fixing seat, and then insert the screw.
- Place the $\Phi 8$ gasket on the screw and insert the cotter pin into the screw hole for fixing.

(install the other side in the same way)

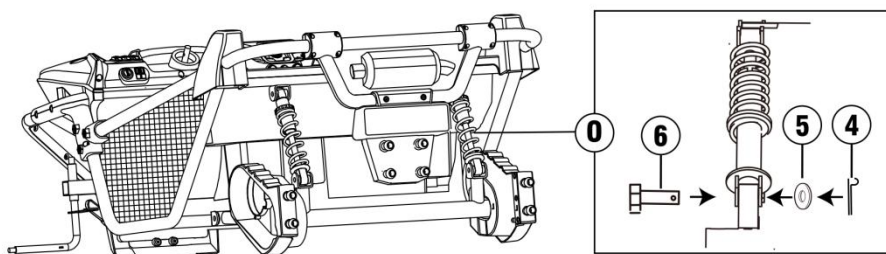

PRODUCT ASSEMBLY

H Fix the rear bumper decoration.

- Clip the rear bumper decoration into the body slot.

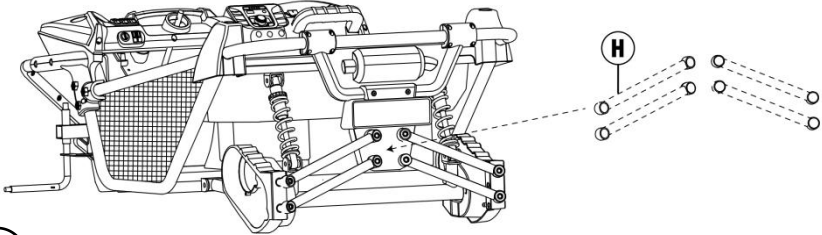

N Fix the rear axle.

- Clip the rear axle into the body slot.

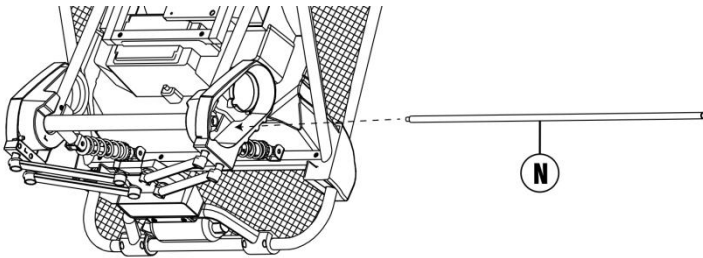

J Fix the gear box (L/R).

- Put the gear box into the rear axle, and stuck the motor into the body slot.
- Thread the transmission wire into the body hole to the battery compartment.

(Tips: gear box left right distinction)

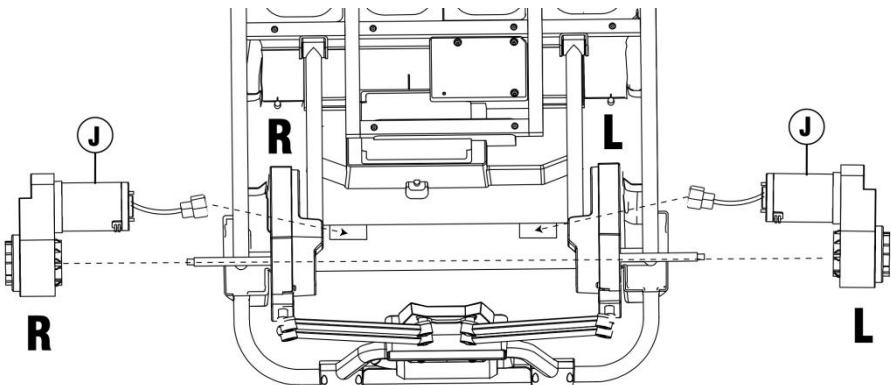

PRODUCT ASSEMBLY

Put the washer, front wheel, $\phi 12$ washer and nut into the front axle in turn.

Fix the nut with the M10 wrench and then attach the wheel cover to the front wheel.

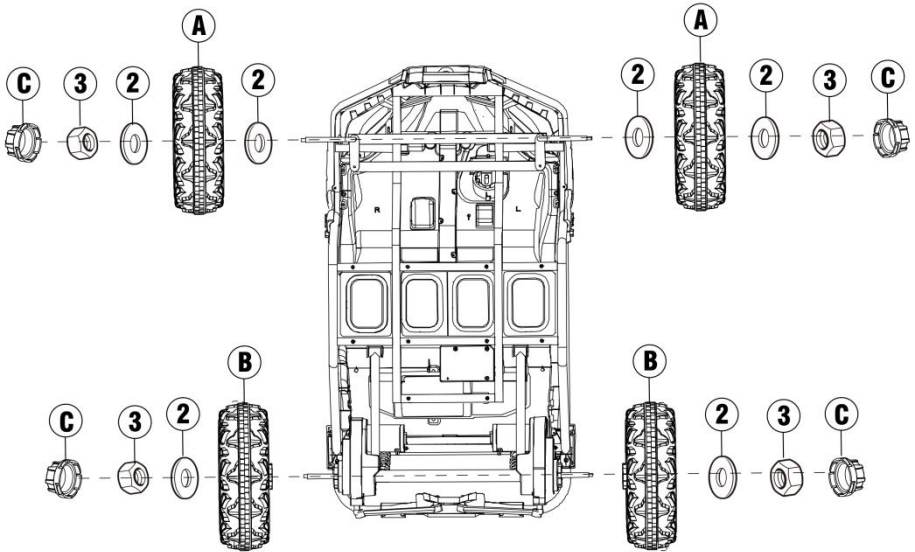

Place the rear wheel, $\phi 12$ washer, and nut on the rear axle in turn.

Fix the nut with the M10 wrench and then attach the wheel cover to the rear wheel.

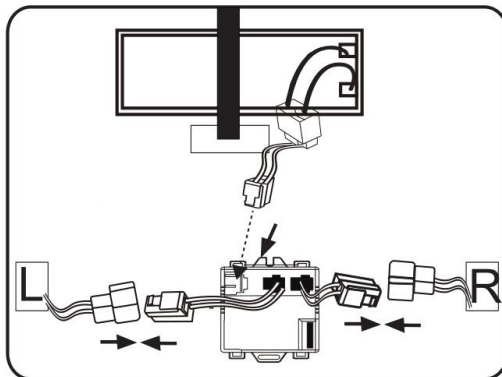

Put the car upside down

Find the main power cord under the seat, and insert the plug of the power cord into the corresponding socket of the receiver. The plug of the drive motor cable is docked with the plug on the receiver

D Fix the steering wheel.

- Remove the nut and bolt from the steering wheel.
- Connect the wires coming from the steering column to the wires on the steering wheel.
- Insert the steering wheel over the steering and secure with nut and bolt.

G Fix the seat.

- Insert the lower seat cover into the upper seat cover.
- Stuck the seat buckle into the vehicle slot.
- Fix with screws.

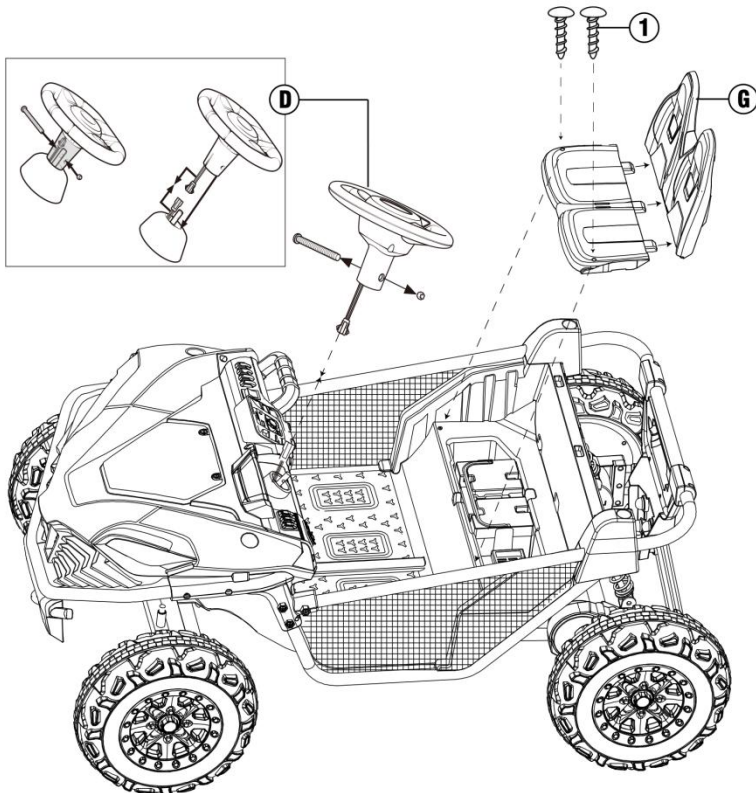

PRODUCT ASSEMBLY

F Use a screwdriver to remove the searchlight battery cover screws and install them in sequence.

- Put the battery into the battery card slot after distinguishing the positive and negative poles.
- Cover the battery cover and fix it with screws.
- Power switch: (-)=on, (o)=off.

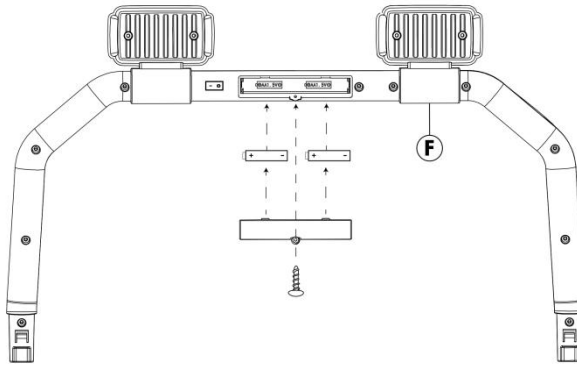

F Fix the searchlight.

- Stuck the searchlight into the corresponding slot on the body.

E Fix the front block.

- Stuck the front block into the corresponding slot on the body.

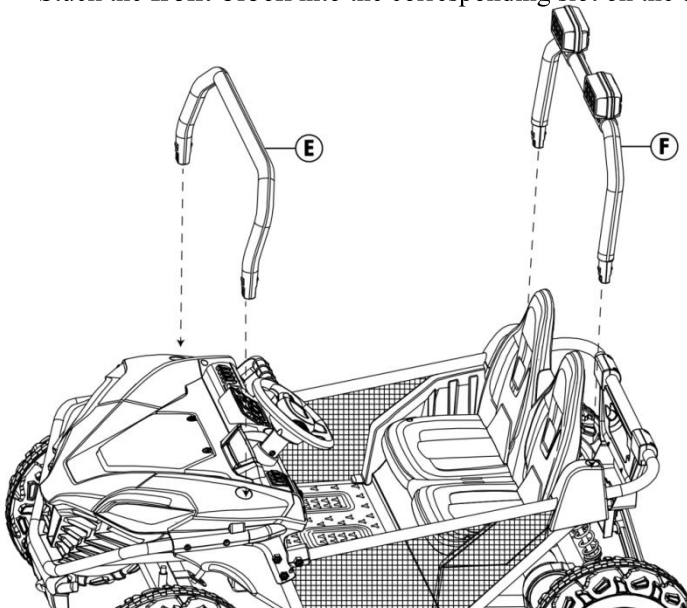

PRODUCT ASSEMBLY

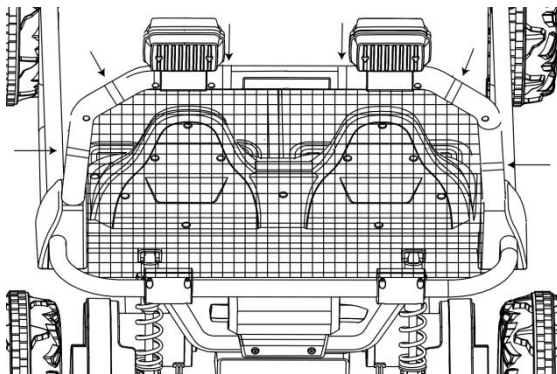

As shown in the figure

Secure the net bag to the searchlight the Velcro on the net bag.

DASHBOARD DIAGRAM

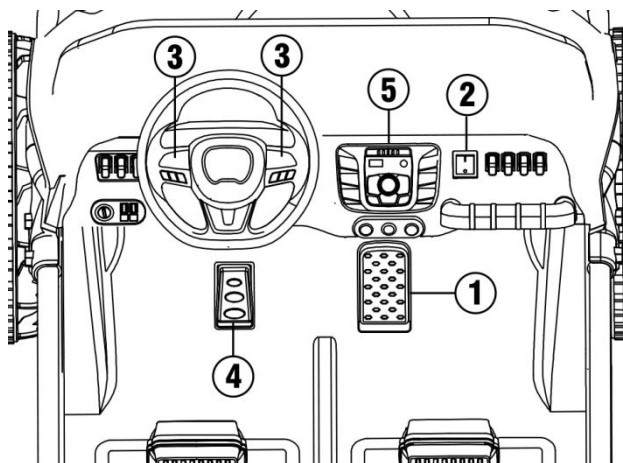

1. Pedal button: Step on the button , the car will move when, release the car slowly stop.
2. Shift Switch: Change the direction of the car , Forward-Backward.
3. Horn button: press to play the horn.
4. Brake button: press the switch and the vehicle will stop slowly.
5. Control board:

DASHBOARD DIAGRAM

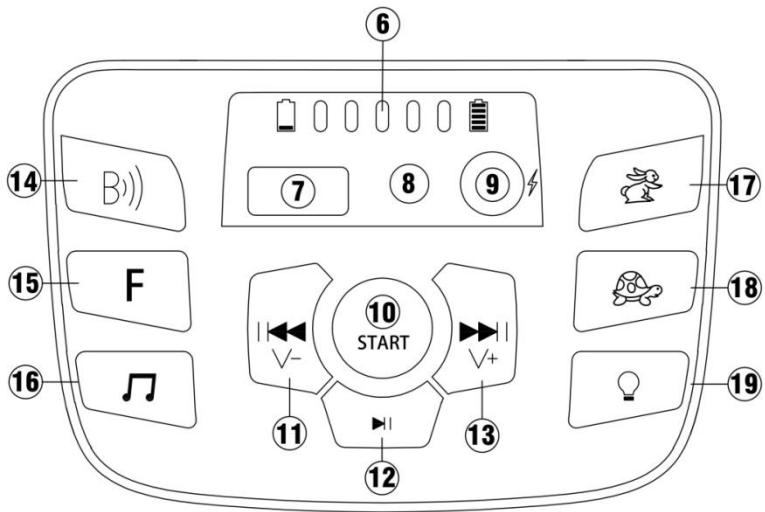

6. Power display: : clearly see the battery power and help judge whether the battery needs to be charged.
7. U:
8. MP3:
9. Socket: : charge.
10. Power button: Long Press it 3 seconds,Turn the vehicle on and off.
11. Last song/volume-: press it to switch to the last song and long press can decrease volume.
12. Pause button: : press it to pause music;
13. Next song/volume+: press it to switch to the next song and long press can increase volume.
14. Wireless Technology : After connected your mobile phone and the wireless device ,the car can play music from your mobile phone.
15. F: Radio, long press it 2-3 seconds,Automatic search.
16. Music Button: press it to play music
17. High speed button: press it to change the car to the high-speed movement.
18. Low speed button: press it to change the car to the low-speed movement.
19. Light button: press it to switch the light.

REMOTE CONTROL DIAGRAM

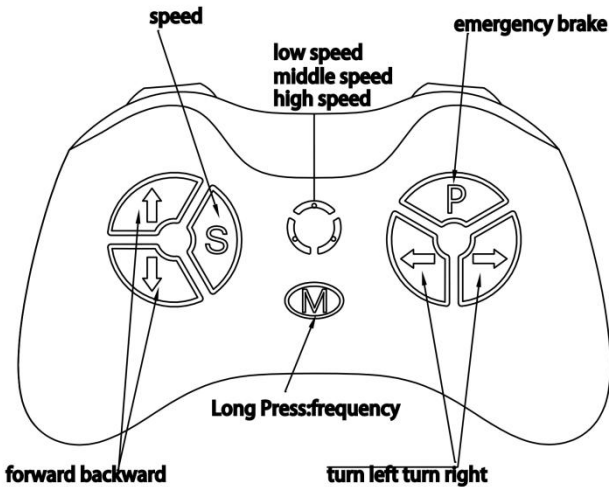

Warning

Only used by adults

Remote control first. When the remote control is on, foot pedal is not workable

Operation Manual:

Take out the remote control, Open the battery compartment on the back of the remote control and add two AAA LRO3 alkaline batteries. Pay attention to the polarity of the batteries. When the alignment light and speed indicator light up, it indicates that the battery installed is correct. This product does not provide dry batteries.

<Button Description >

(1) Long press on the frequency key(M) 2-4 seconds, Low speed LED light flashing. Turn on the power of the car, Low speed LED light keep flashing to long lighting, then frequency bind succeed. If the frequency bind failed (Low speed LED light flashing), remove the battery and repeat steps

P: Press to brake。

S: Speed: press to change speed(low,middle and high speed).

△Forward ▽backward。

◁ Turn left ▷ turn right

- 2) Brake button: Press it to stop moving; press it again to move.
- 3) Speed selection key and speed indication: used to select speed of the car. Press the key once to switch the speed once. 3 speeds are cyclically switched, and the switching sequence is: low-medium-high. The speed indicator is arranged from top to bottom on the remote control: high-speed lamp, medium-speed lamp, low-speed lamp; when switching to one speed, the corresponding indicator lamp will light up. Note: The speed grade changes only when moving forward
- 4) Forward/backward keys: used for forward and backward movement control. When one of the keys is pressed, the moving speed will slowly increase to reach the set speed level. Therefore, children will not have a sudden impact.
- 5) Left turn/right turn key: used for left and right direction control.

Note: without operation after 10 seconds, indication light will off into power saving mode

 **WARNING:** The remote control is not a toy. It is for the adult use only, and should not be used by a child. A close adult supervision is always required. Reception range may change significantly with weather, battery, and other environmental conditions.

CHARGING INSTRUCTIONS

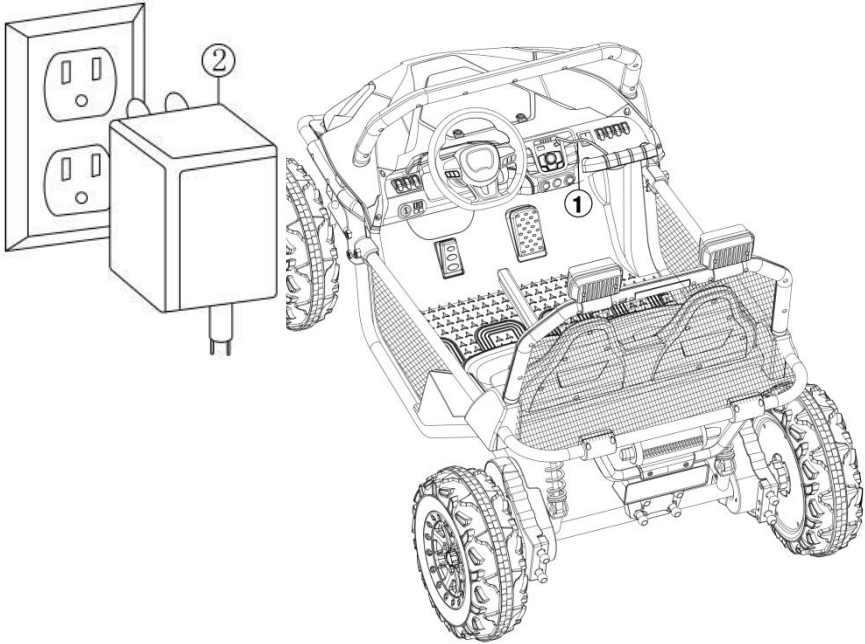

- 1.Insert the charger jack into the charging hole of the car.
- 2.Plug the charger plug into the stable matching AC power supply as shown in the picture.

- Charge the battery 15 to 18 hours before initial use.
- On average,you will need to charge the battery between 8 and 12 hours.Do not charge the battery for more than 20 hours.Failure to charge the battery as directed could cause permanent damage to the battery and void the warranty
- Damage to the battery may occur if it is allowed to drain completely.Do not allow the battery to drain completely.
- Check the battery and charger (supply cord,connector) for wear and damage before charging.DO not charge the battery if damage has occurred.
- Only an adult who has read and understood the safety warnings should handle,charge and recharge the battery.

CARING FOR YOUR RIDE-ON

- Park the vehicle indoors or cover it with a tarp to protect it from wet weather.
- Do not leave the vehicle in the sun for long periods of time or fading may occur. Store in shade or cover with tarp.
- Do not wash the vehicle with a hose.
- Do not wash the vehicle with soap.
- Charge battery at least once a month to prolong the life of the battery.

TROUBLESHOOTING

PROBLEM	REASON	SOLUTION
Vehicle does not move	Low battery	Fully charge the battery
	Electrical protection	Stop use for several minutes and restart
	Switch not in the correct position	Completely press in switches
	Battery connectors disconnected	Plug in battery connectors
Battery does not recharge	Battery connectors disconnected	Plug in battery connectors
	Charge not connected to socket or outlet	Completely plug in the charger
Battery does not last	Battery does not have a full charge	Fully charge the battery
Battery is warm and makes a slight noise while charging	Normal	Normal
Slow speed	Low battery	Fully charge the battery
	Overloaded vehicle	Reduce the weight on the vehicle
	Uneven or sloped road	Drive on flat pavement
Vehicles shakes while driving	Loose connection to motor	Ensure the motor is properly connected to the battery
Difficulty shifting between forward/reverse	Attempting to shift while vehicle in motion	Only shift when the vehicle is at a stop
Forward and reverse switch is flipped	Gear boxes are installed incorrectly	Make sure the L gear box is on the left and R gear box is on the right

WARNINGS REGARDING BATTERIES

The battery on the vehicle is not replaceable.

- DO not mix old and new batteries.
DO not mix alkaline,standard(carbon-zinc),or rechargeable batteries.
- Non-rechargeable batteries should not be charged.
- Rechargeable batteries shall be charged by adult or by children at least 8 years old.
- Exhausted batteries should be removed.
- The supply terminals should not be short-circuited.
- Do not put batteries next to or in a heat source(fire,electronic heating device,etc.)
- Do not hit batteries against hard objects.
- Do not submerge batteries in water.
- Batteries should be inserted with the correct polarity.



WARNING:

- Protective equipment should be worn.Not to be used in traffic.
- The toy should be used with caution since skill is required to avoid falls or collisions causing injury to the user or third parties.
- To reduce the risk of injury,adult supervision is required.Never use in roadways.near motor vehicles,on or near steep inclines or steps,swimming pools or other bodies of water;always wear shoes,and never allow more than 2 riders.



WARNING: ADULT ASSEMBLY REQUIRED



WARNING: Not to be used in traffic



WARNING: CHOLING HAZARD-Small parts.

Not for children under 3yrs.

To reduce the risk of injury,adult supervision is required.

Never use in roadways.near motor vehicles,on or

Near steep inclines or steps,swimming poors or other bodies of

Water;always wear shoes,and never allow more than 2 riders.

IMPORTANT

- Always charge battery for a FULL 18hrs the first time you use it.
- Always charge battery for a FULL 10hrs after each use.
- Charge the battery once a month. even if you are not using your vehicle.

FCC Statement

Caution:

This device complies with Part 15 of the FCC Rules. Operation is subject to the following two conditions: (1) this device may not cause harmful interference. (2) this device must accept any interference received, including interference that may cause undesired operation.

Changes or modifications not expressly approved by the party responsible for compliance could void the user's authority to operate the equipment.

This equipment has been tested and found to comply with the limits for a Class B digital device, pursuant to part 15 of the FCC Rules. These limits are designed to provide reasonable protection against harmful interference in a residential installation. This equipment generates uses and can radiate radio frequency energy and, if not installed and used in accordance with the instructions, may cause harmful interference to radio communications. However, there is no guarantee that interference will not occur in a particular installation. If this equipment does cause harmful interference to radio or television reception, which can be determined by turning the equipment off and on, the user is encouraged to try to correct the interference by one or more of the following measures:

- Reorient or relocate the receiving antenna.
- Increase the separation between the equipment and receiver.
- Connect the equipment into an outlet on a circuit different from that to which the receiver is connected.
- Consult the dealer or an experienced radio/TV technician for help.