

# 10' × 8' Tool Storage Shed

## **ASSEMBLY MANUAL**

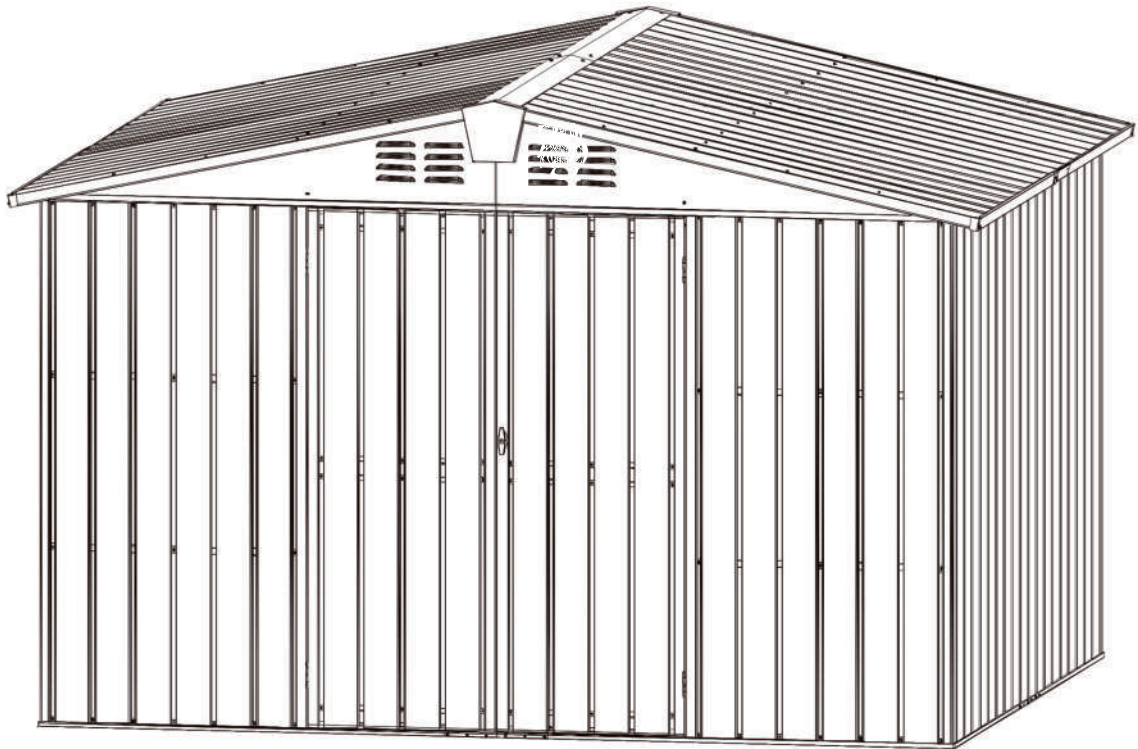

MODEL#: LGCF1552

# Pre-assembly



1. Two or more people are required for assembly.



2. You will need one or more stepladders.



3. Wearing protective gloves is recommended.



4. You may need a safety hat.



5. Please use a Phillips screw driver.



6. For ease of construction, you may need a drill.



7. You may need a safety goggle.



8. Do not fully tighten screws prior to complete assembly.

## Warning & Attention

-Try to assemble this product on the flat ground, otherwise it is difficult to carry out;

-It would be much easier to assemble the product with two or more people;

-After assembly, please check whether all screws are tightened, to prevent parts from falling apart.

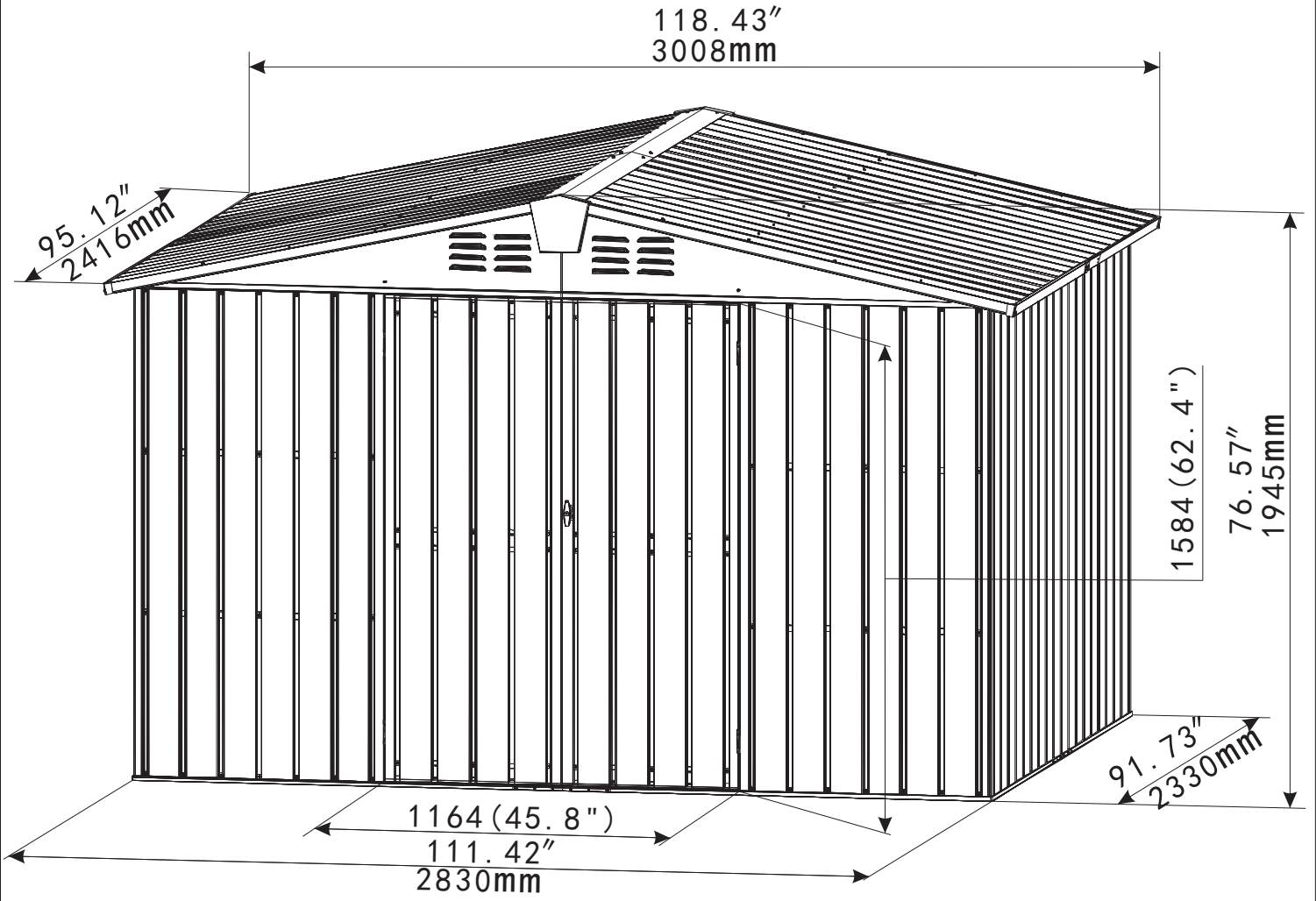

1552

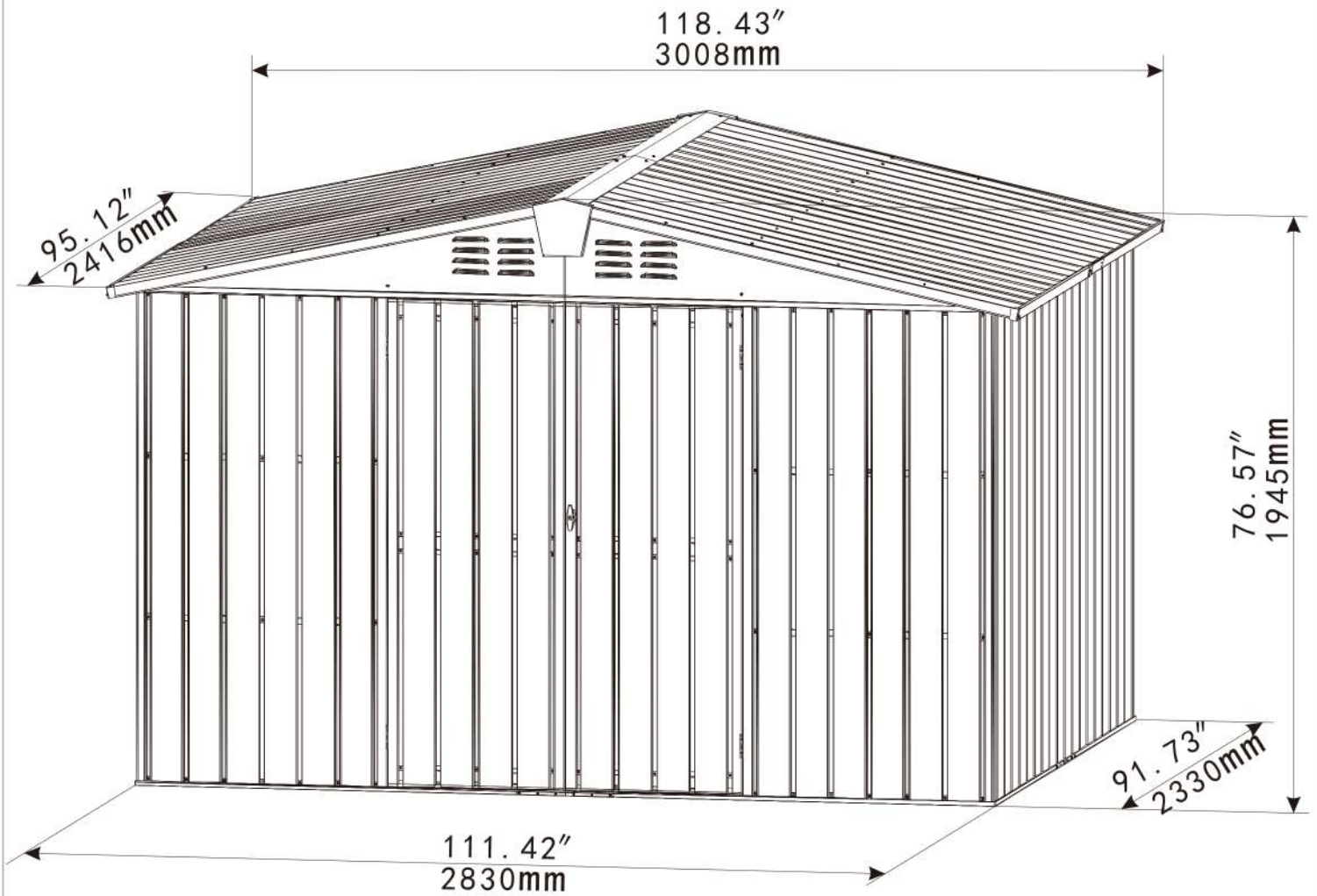





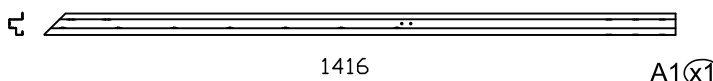
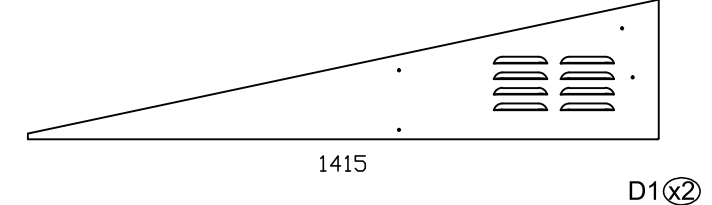
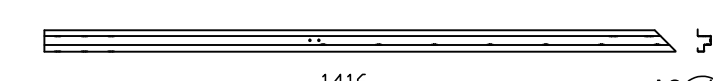
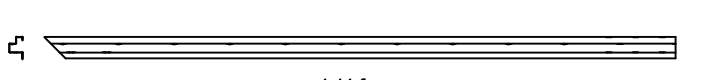
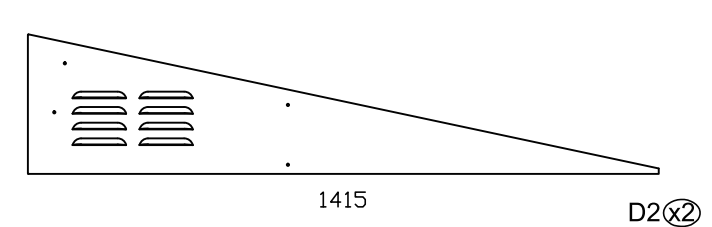
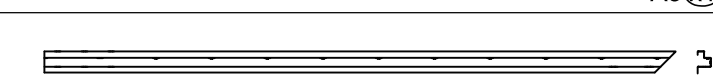
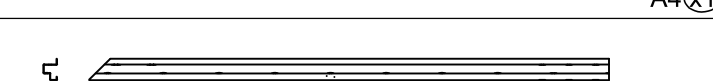
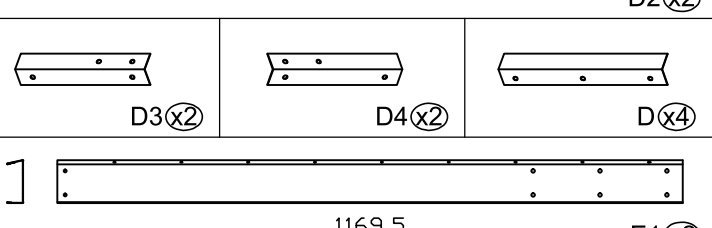
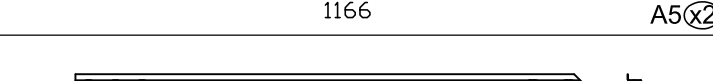
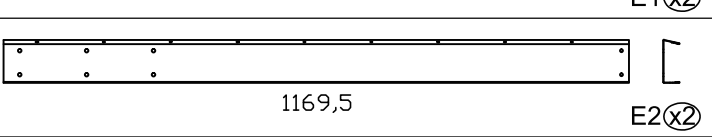
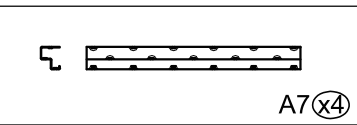
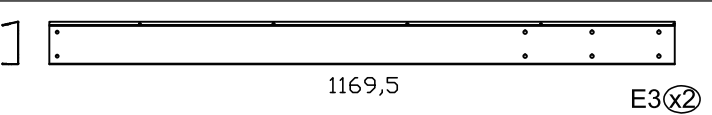
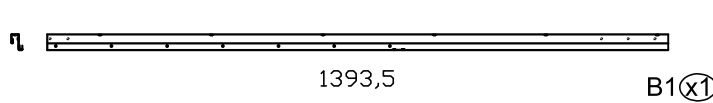
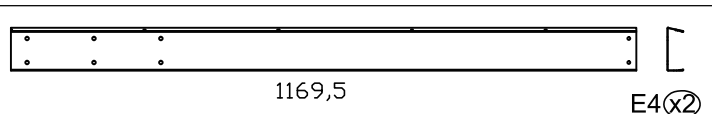
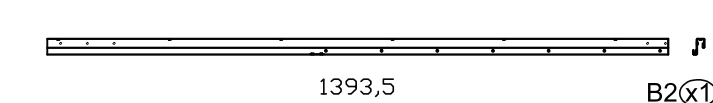
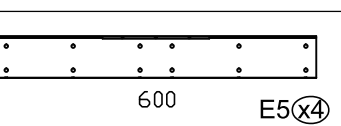
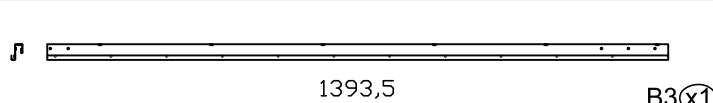
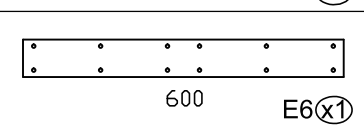
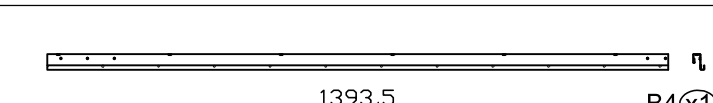
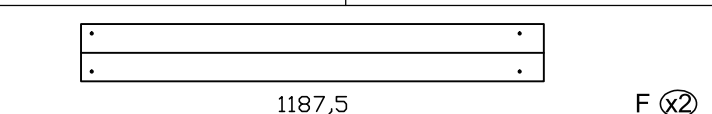
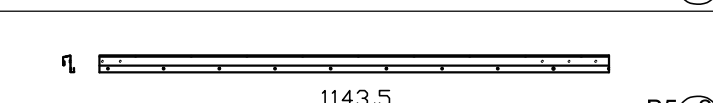
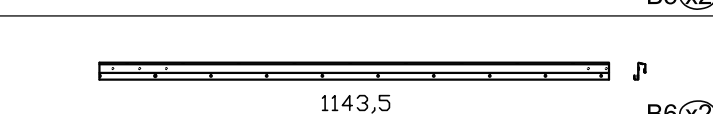
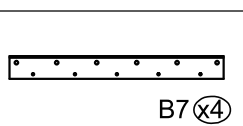
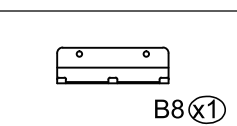
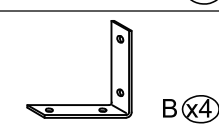
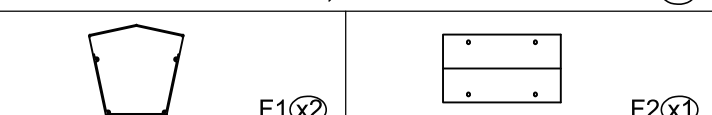
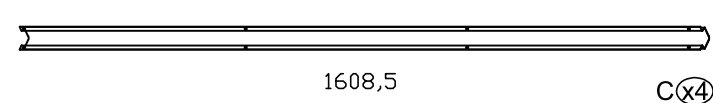
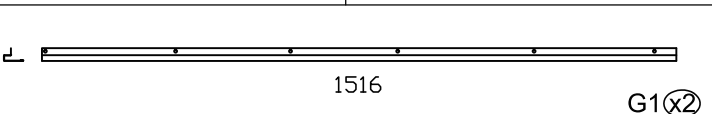
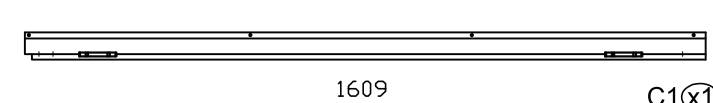
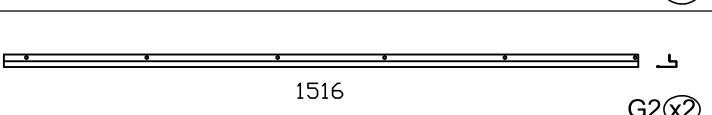
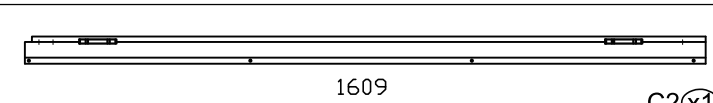
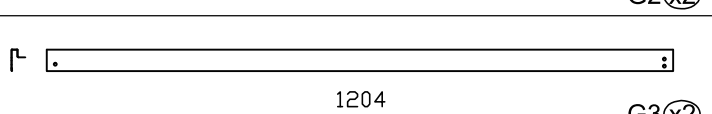
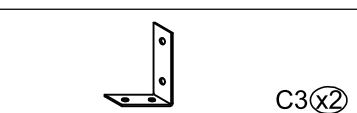
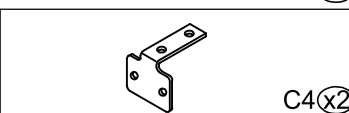
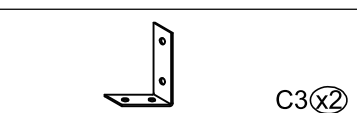
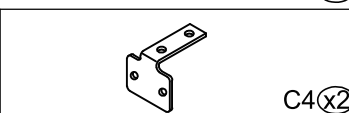



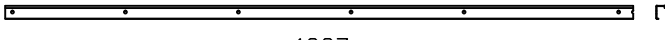
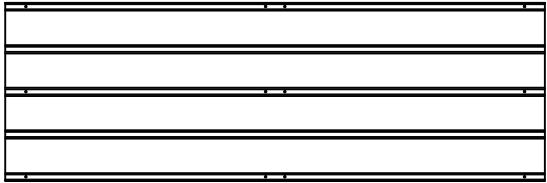

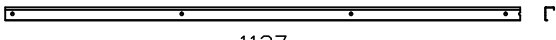
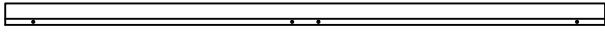
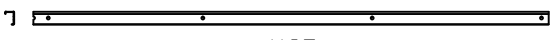
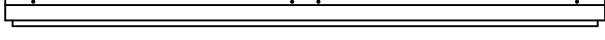
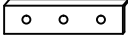
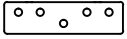

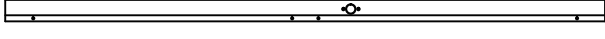

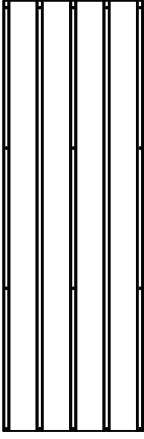
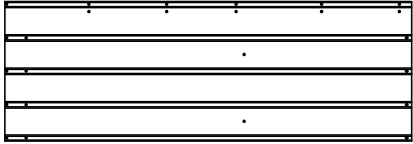

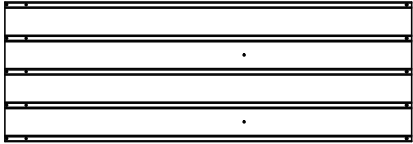

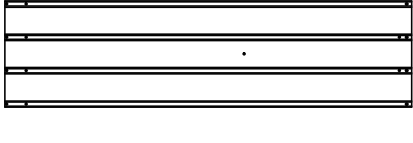
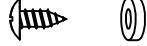
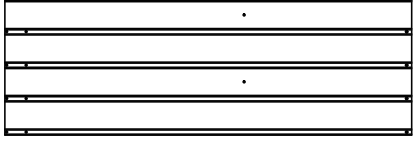



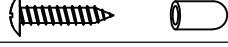

1552-00

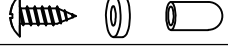
The manual will assist you during the whole process of assembling. Make sure you have all the parts & hardware as list 1 and list 2 shown; prepare the level ground for installation.

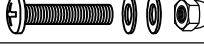
 1416 A1(x1)	 1415 D1(x2)
 1416 A2(x1)	
 1416 A3(x1)	 1415 D2(x2)
 1416 A4(x1)	
 1166 A5(x2)	 1169,5 E1(x2)
 1166 A6(x2)	 1169,5 E2(x2)
 1166 A7(x4)	 1169,5 E3(x2)
 1393,5 B1(x1)	 1169,5 E4(x2)
 1393,5 B2(x1)	 600 E5(x4)
 1393,5 B3(x1)	 600 E6(x1)
 1393,5 B4(x1)	 1187,5 F(x2)
 1143,5 B5(x2)	 1143,5 B6(x2)
 1143,5 B7(x4)	 1143,5 B8(x1)
 1143,5 B(x4)	 1516 G1(x2)
 1608,5 C(x4)	 1516 G2(x2)
 1609 C1(x1)	 1204 G3(x2)
 1609 C2(x1)	 1204 G4(x2)
 801 H1(x2)	 801 H2(x2)
 801 H1(x2)	 801 H2(x2)

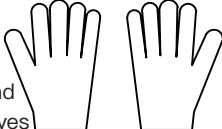
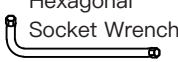
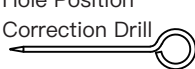
List-1

 1387 H3 (x2)		 1582 M (x2)	
 1387 H4 (x2)			
 1137 H5 (x4)		 1582 M1 (x2)	
 1137 H6 (x4)		 1582 M2 (x1)	
 H7 (x6)	 Y (x4)	 Z (x58)	 1582 M3 (x1)
 1608 J (x18)		 1608 J1 (x4)	
 1521 K5 (x2)		 M9 (x1)	
 1521 K4 (x2)		 M10 (x1)	
 1521 K3 (x2)		 4x10 1# (x274)	
 1521 K2 (x2)		 M4x6 2# (x120)	
 1521 K1 (x2)		 M4x8 3# (x66)	
		 4x20 4# (x36)	
		 4x22 5# (x18)	
		 M4x10 6# (x12)	
		 ST4.2x22 7# (x8)	
		 M4x8 8# (x8)	
		 4x12 9# (x94)	
		 M4x8 10# (x24)	
		 M4x20 11# (x4)	
		 4x16 12# (x40)	
 Hand Gloves		 Hexagonal Socket Wrench	 Hole Position Correction Drill
		 Cross Screwdriver	



Hole position correction drill

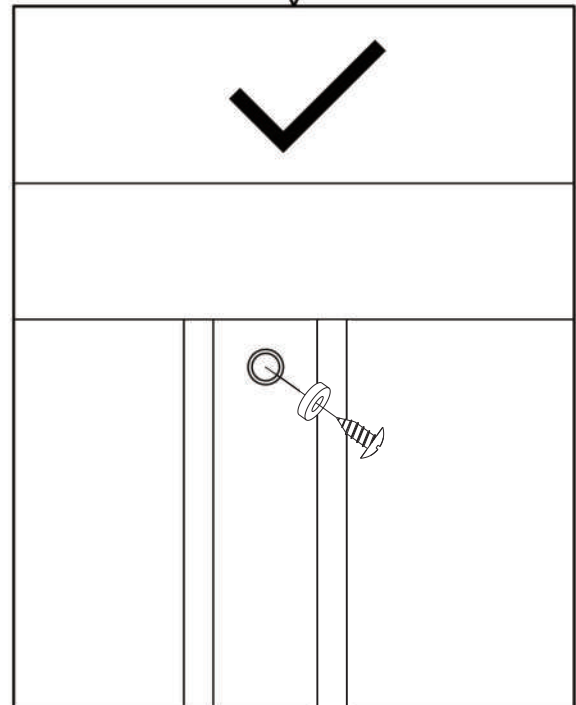
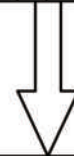
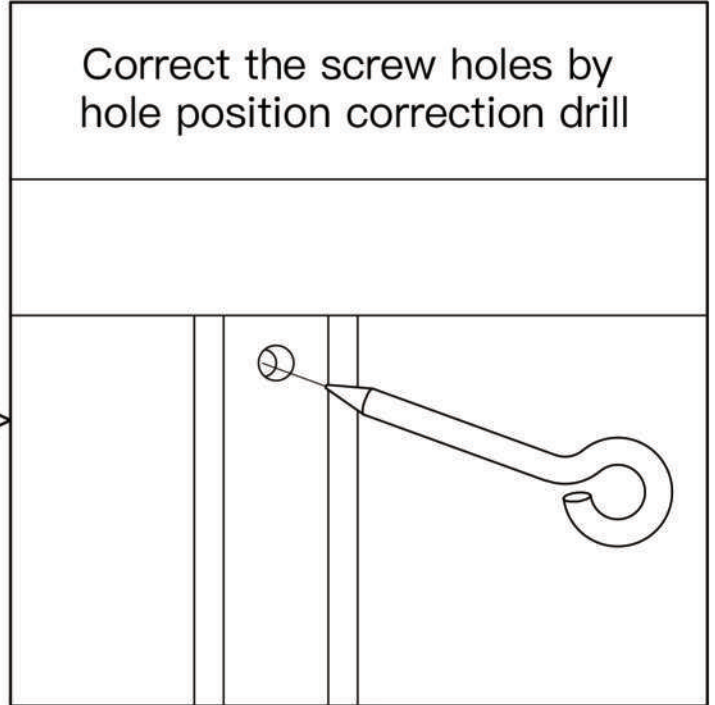
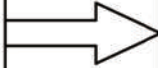
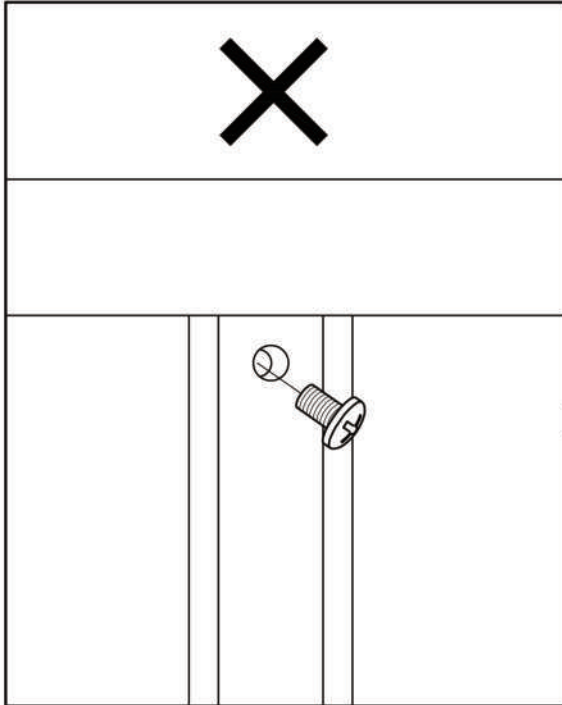

If the screw holes are not symmetrical, you can use this tool to correct the hole position.

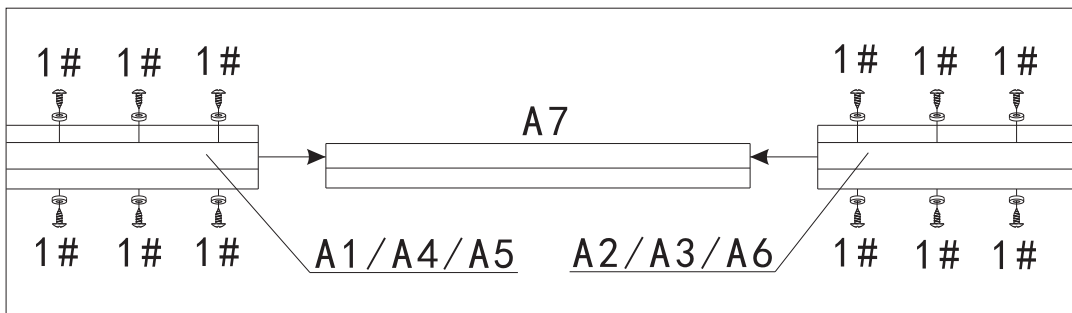
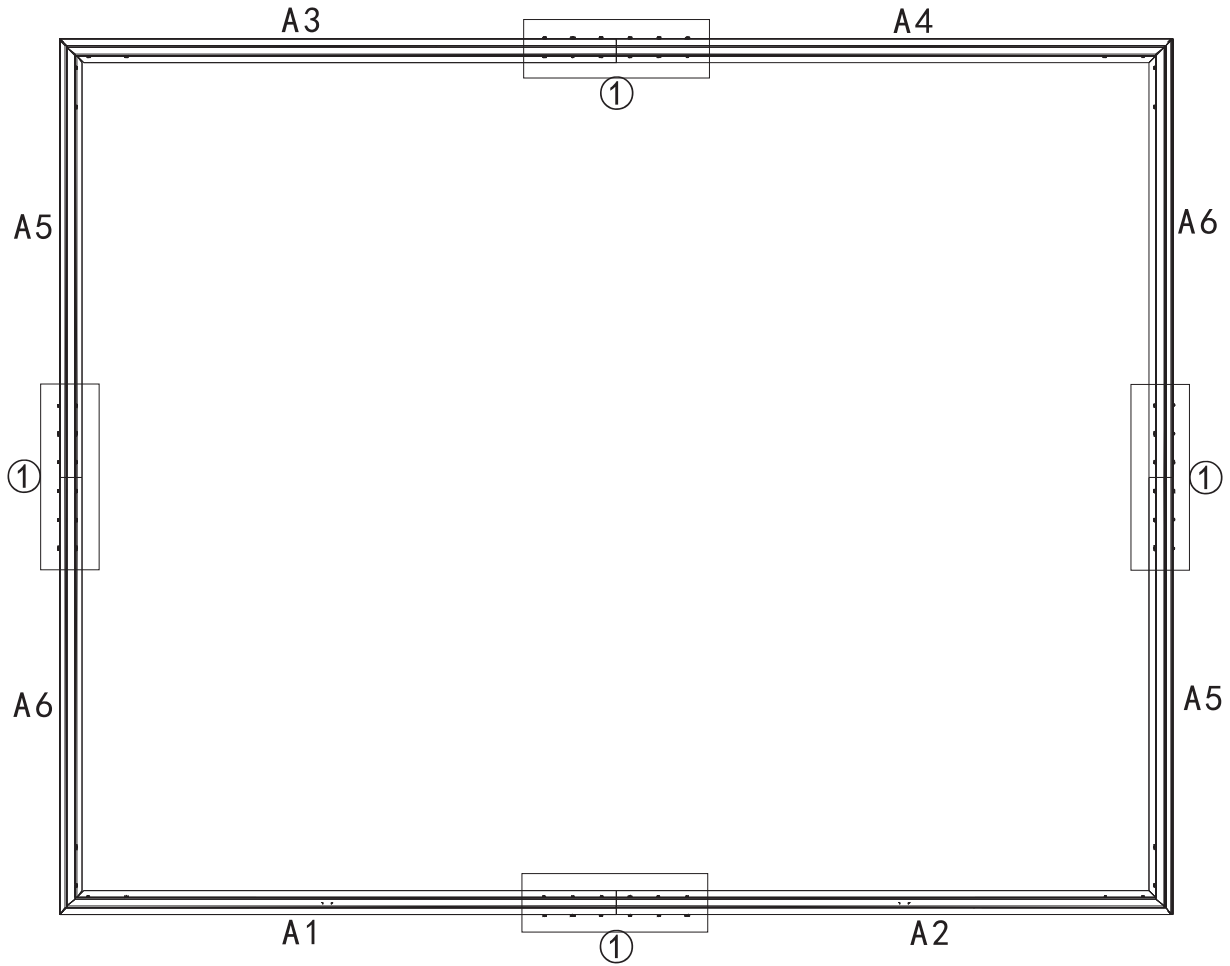
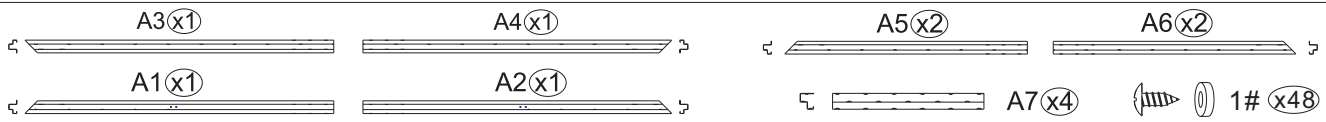

1. Firstly, use the part#A7 to connect part#A1(A4/A5) with part#A2(A3/A6) respectively, and then form the bottom frame as shown.

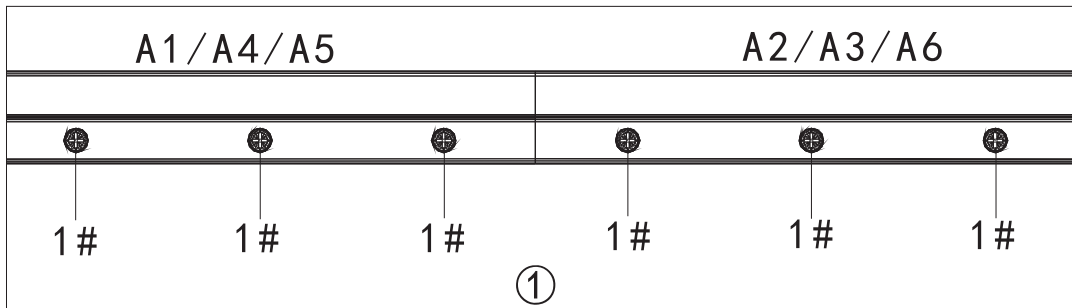

Plastic Gaskets 1# (x16)

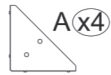

Plastic Gaskets 9# (x4)

2. Fix the corners with part#A and fasten with screws 1# and gaskets.

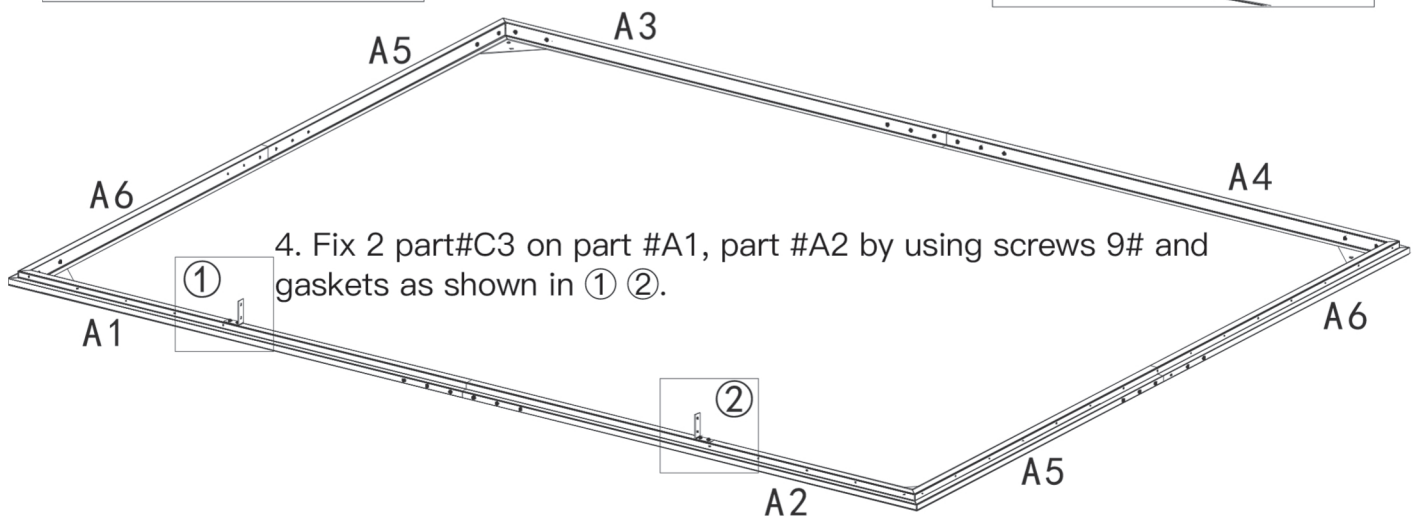
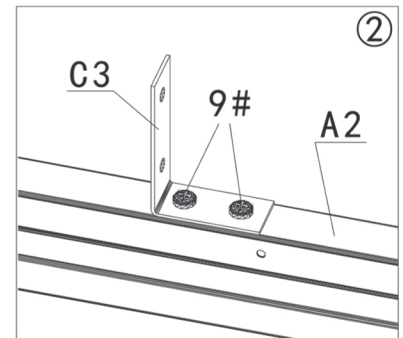
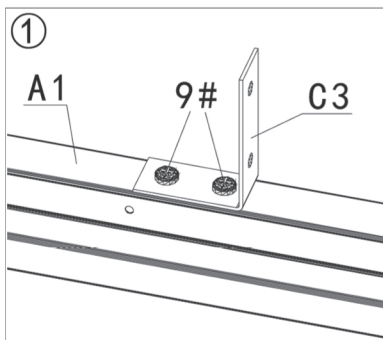
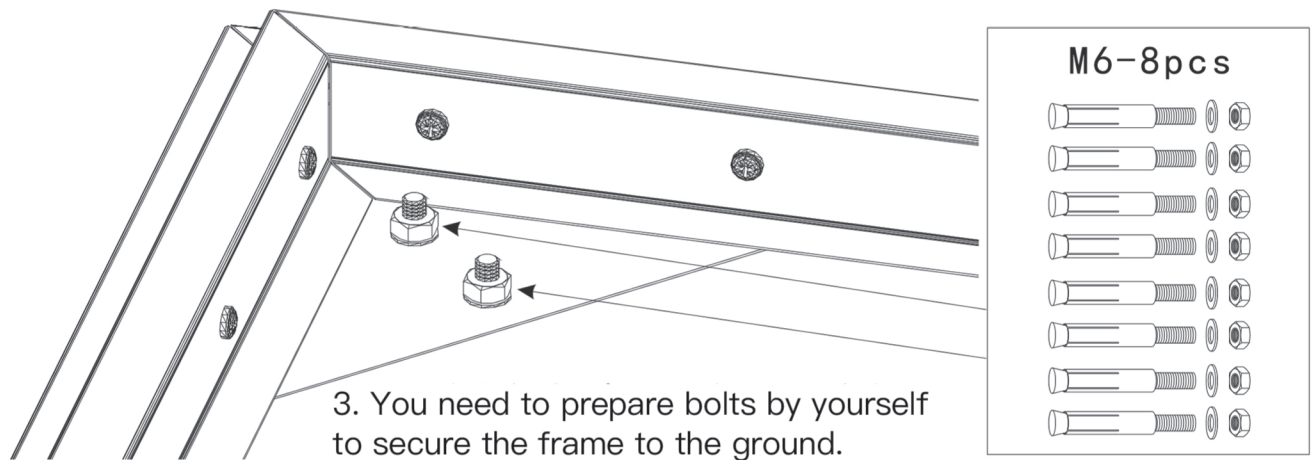
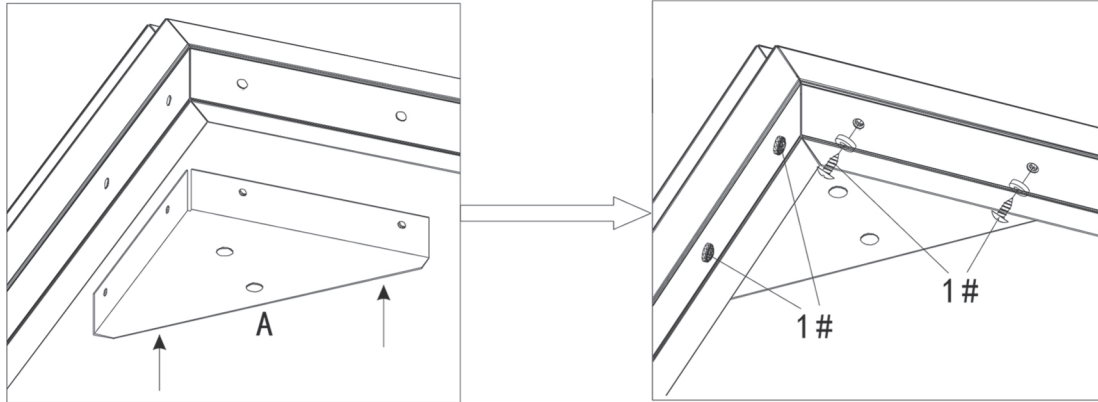

▲ Attention: four corners MUST be right angles and check if the two diagonal distance of square is equal by tape measure.

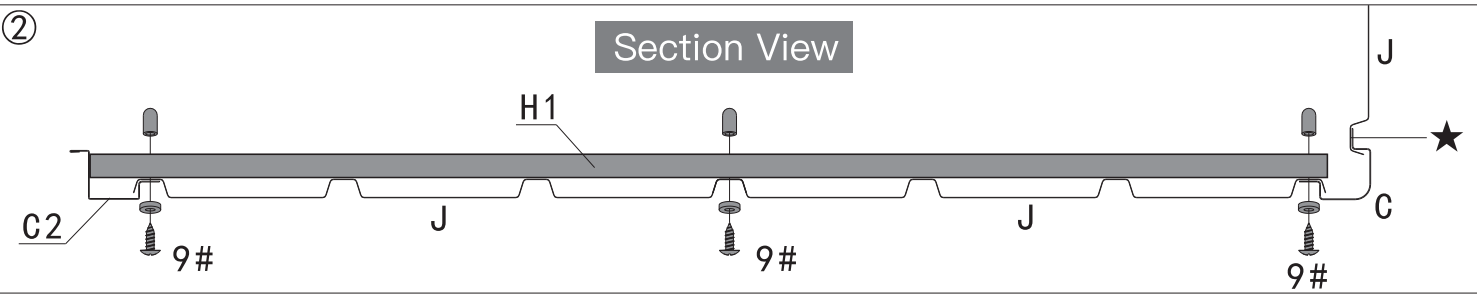
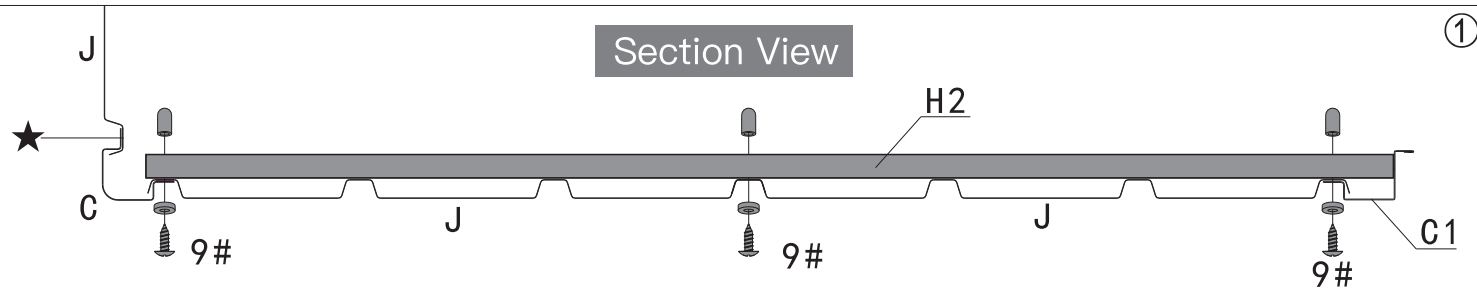
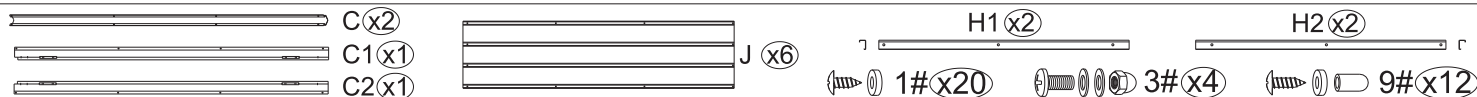

Step 1: Use 6 screws 9#, gaskets and caps to connect 2 part H2 with part #C/J/J/C1 as shown in ① to form a front side wall panel.

Step 2: Place the assembled front side wall panel (#C/J/J/C1) on the bottom frame(A1), using 7 screws 1# and gaskets to fix.

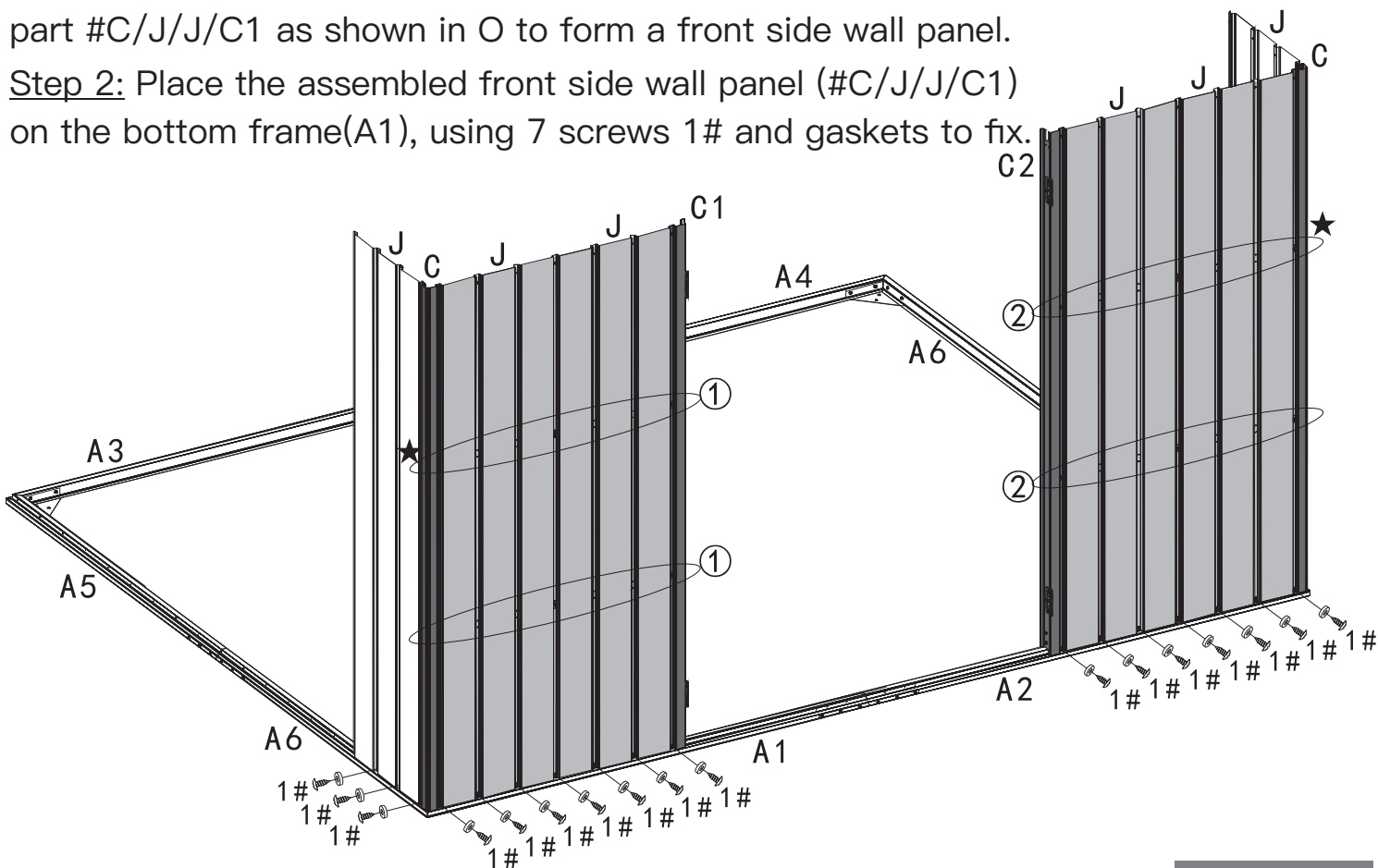

Back View

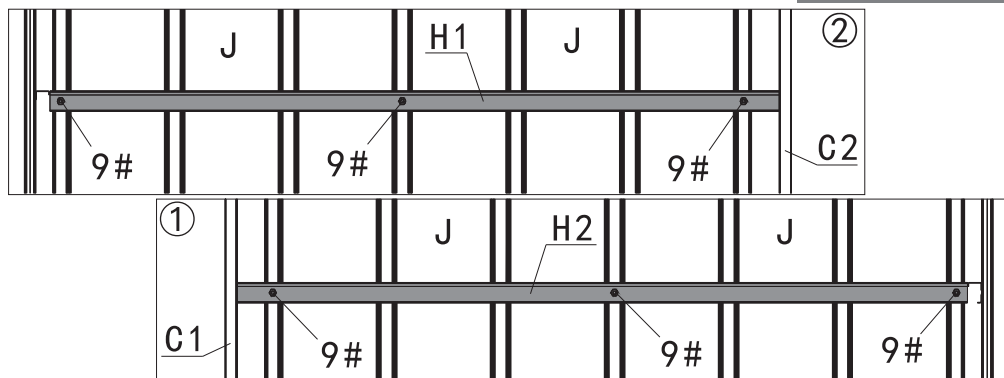
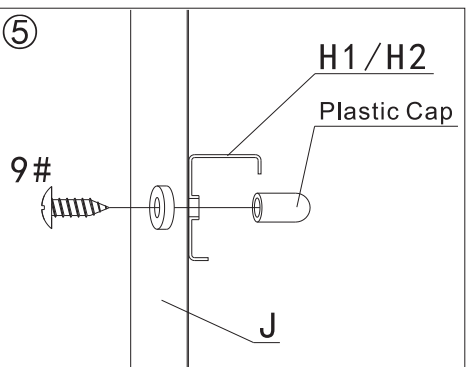

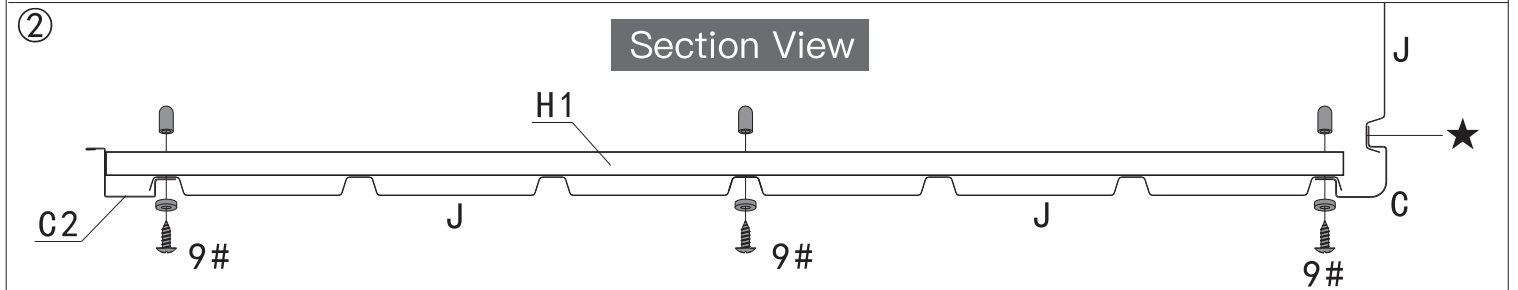
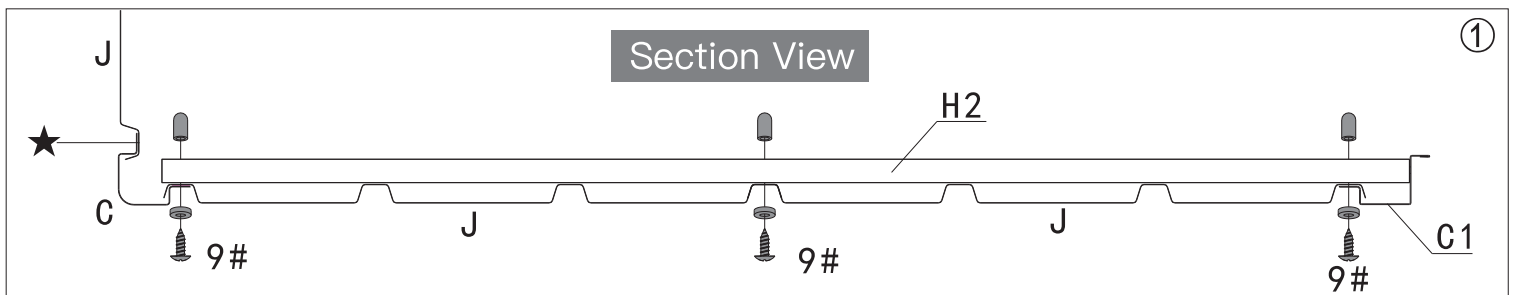

**Step 3:** Place part#J on the bottom frame(A6), using 3 screws 1# and gaskets to fix. Repeat the above procedures to assemble the another side.

**Step 4:** Fix the part #C3 to the part #C1(C2) with 2 screws 3#, 2 gaskets and nuts each as shown in ③④.

**Attention:**To ensure the stability of the wall panel(J) during assembly, you can temporarily reinforce this position(☆) with screws 2#, and replace it with other correct screws when the next installation is made.

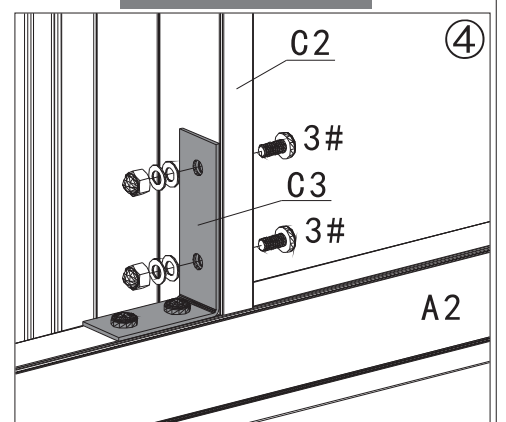
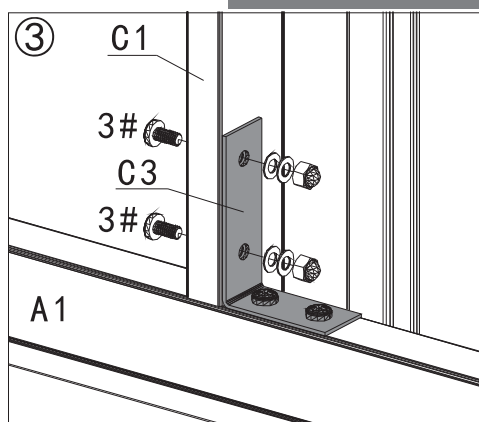
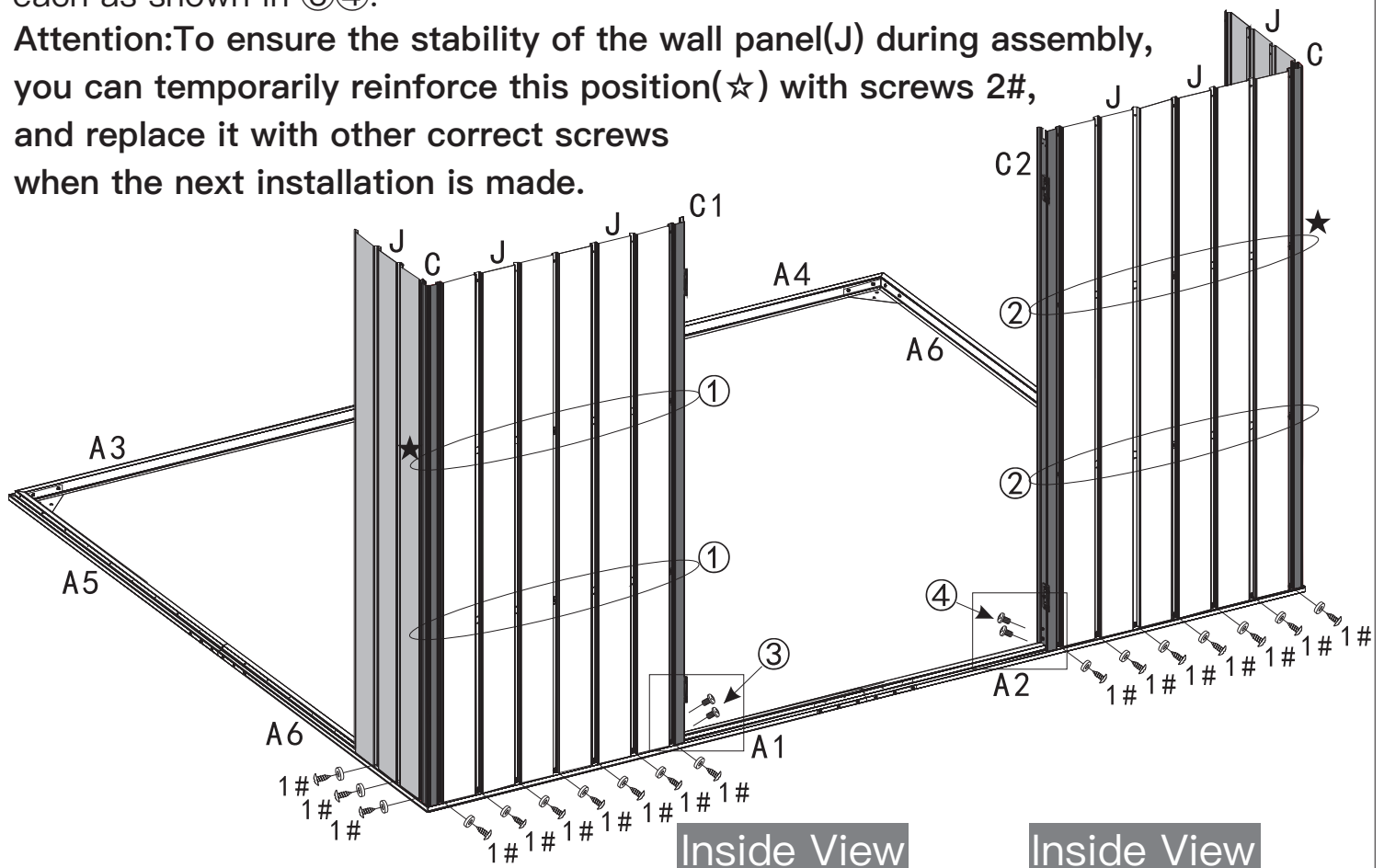

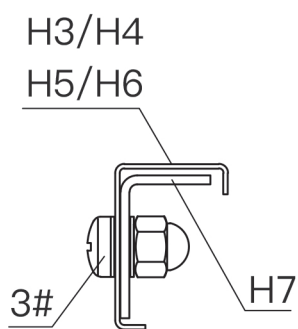
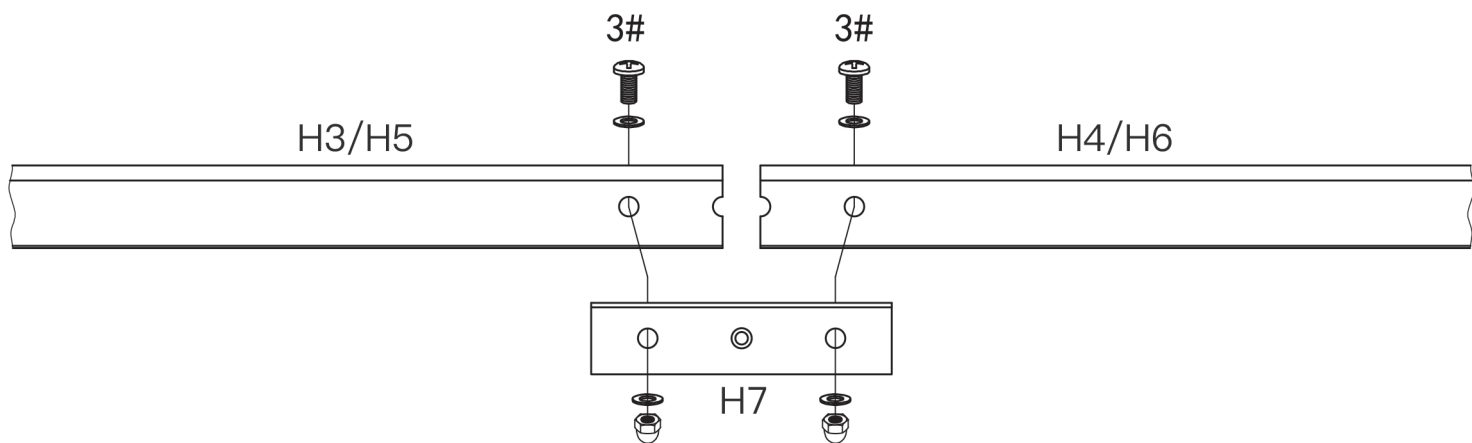
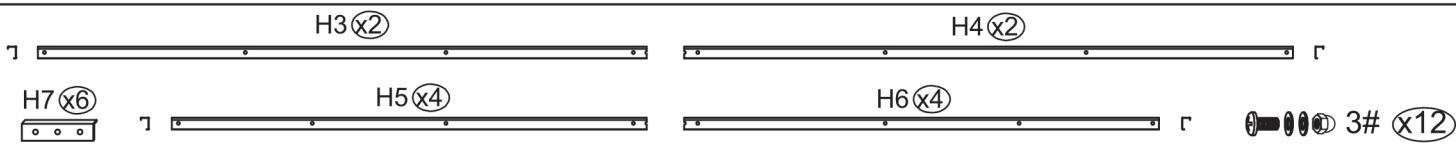

### Side View

Use part#H7 to connect part#H3 and part#H4, and fix by screws 3#, gaskets and nuts.

Repeat the above procedures to connect part#H5 and part#H6.



X2



X4

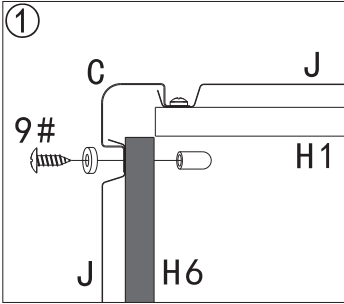
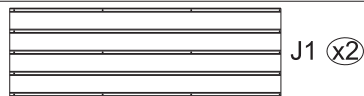
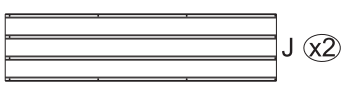

**Step 1:** Place part #J/C/J1 on the bottom frame(A6&A4), using 7 screws 1# and gaskets to fix.

**Step 2:** Use 4 screws 9# and gaskets to install 2 part# (H5+H6) with part#C & J, then put on the plastic caps as shown in ①/③.

**Repeat the above procedures to assemble the another side as shown in ②④**

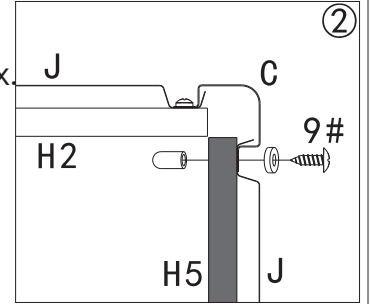

**Step 3:** Use 4 screws 9# and gaskets to install 2 part# (H4+H3) with part#C & J1, then put on the plastic caps as shown in ③/④.

**Step 4:** Use 4 screws 9# and gaskets to install 2 part# (H4+H3) with part#J1, then put on the plastic caps as shown in ⑤.

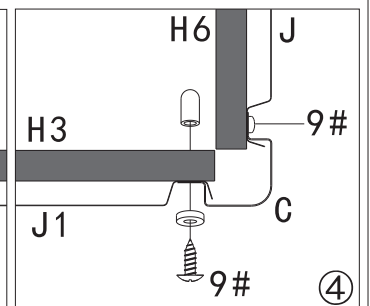
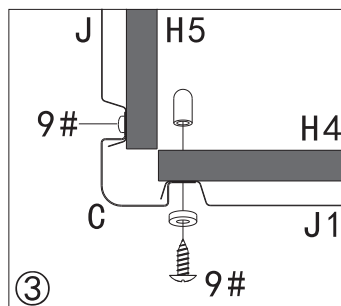
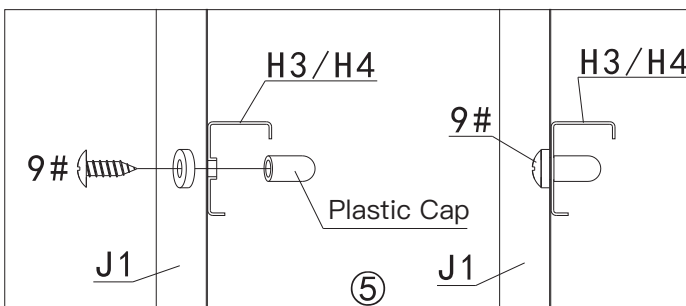
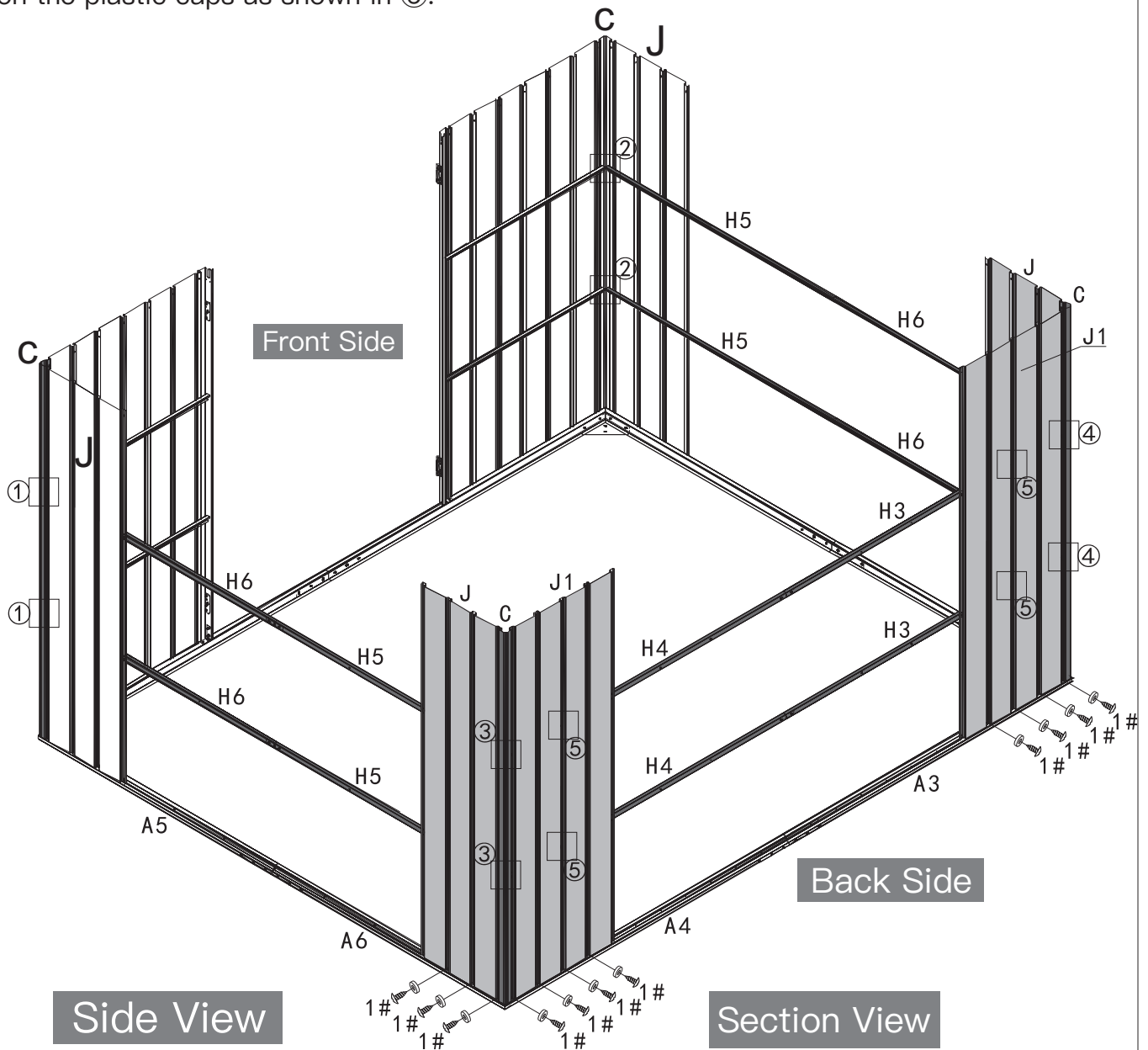

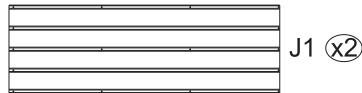

**Step 1:** Use 13 screws 1# and gaskets to fix 4 part#J on the bottom frame (A5 & A6)

**Step 2:** Use 10 screws 9# and gaskets to fix 4 part#J with 2 part# (H5+H6), then put on the plastic caps to form a whole side wall as shown in ①②.

**Repeat the above procedures to assemble another side wall.**

**Step 3:** Use 15 screws 1# and gaskets to fix part#J1&J&J&J1 on the bottom frame (A4 & A3) .

**Step 4:** Use 14 screws 9# and gaskets to fix part#J1&J&J&J1 with 2 part# (H3+H4), then put on the plastic caps to form a whole back wall as shown in ①②.

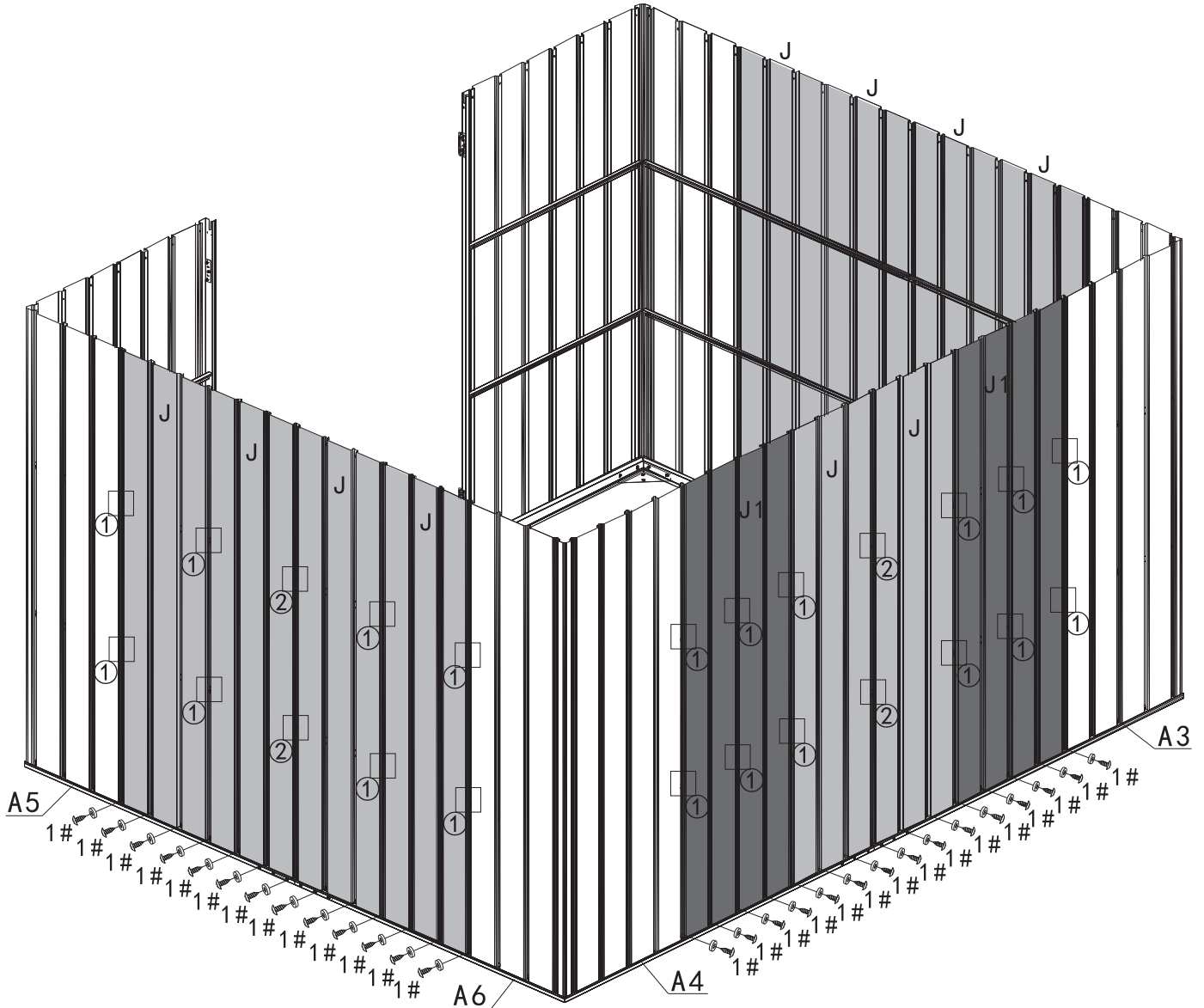

Side View

Side View

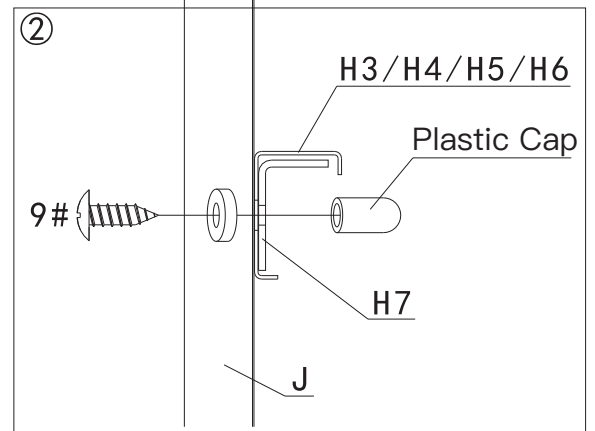
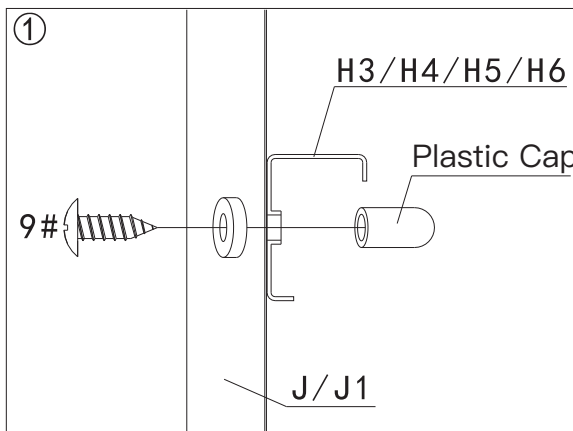

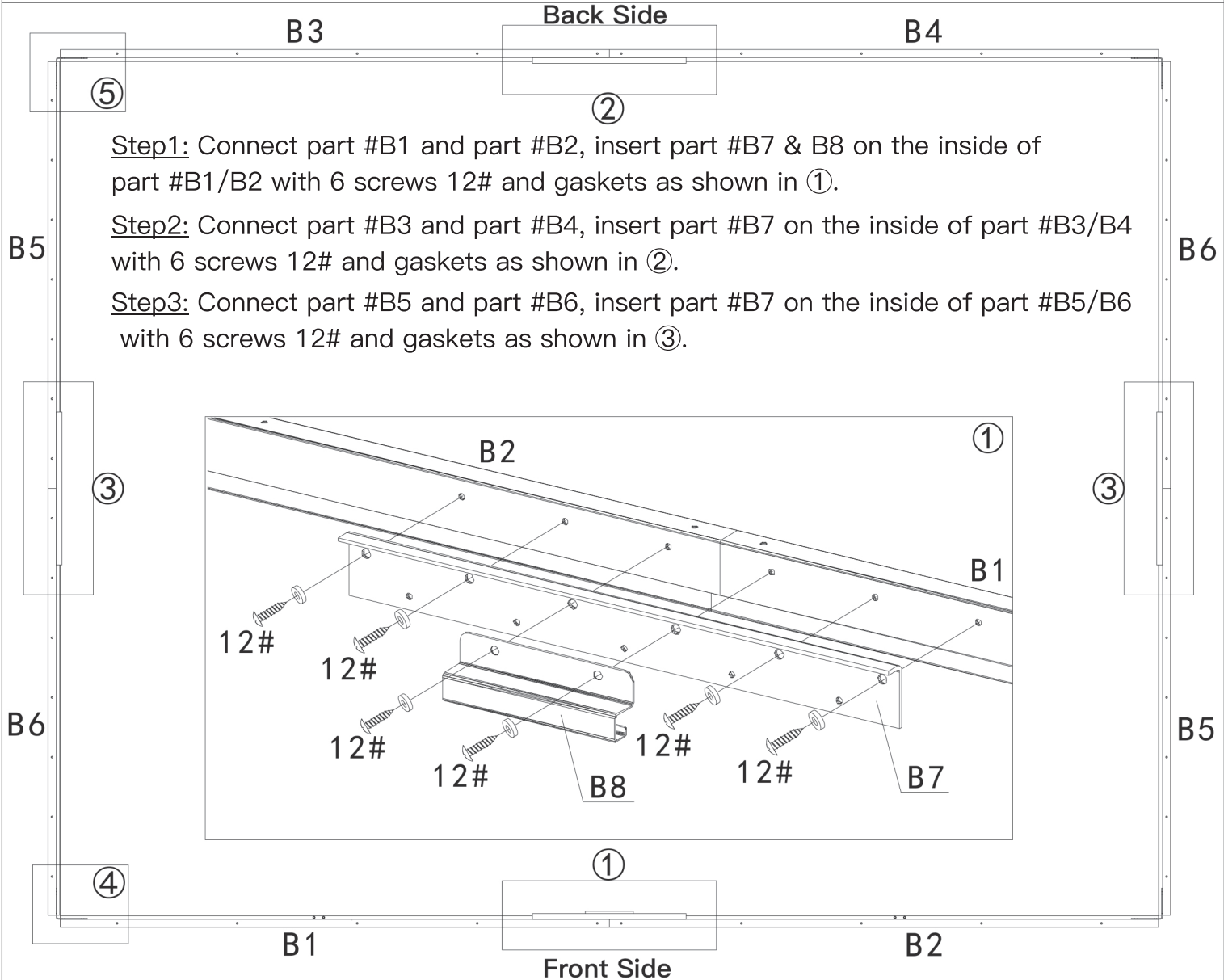

**Step1:** Connect part #B1 and part #B2, insert part #B7 & B8 on the inside of part #B1/B2 with 6 screws 12# and gaskets as shown in ①.

**Step2:** Connect part #B3 and part #B4, insert part #B7 on the inside of part #B3/B4 with 6 screws 12# and gaskets as shown in ②.

**Step3:** Connect part #B5 and part #B6, insert part #B7 on the inside of part #B5/B6 with 6 screws 12# and gaskets as shown in ③.

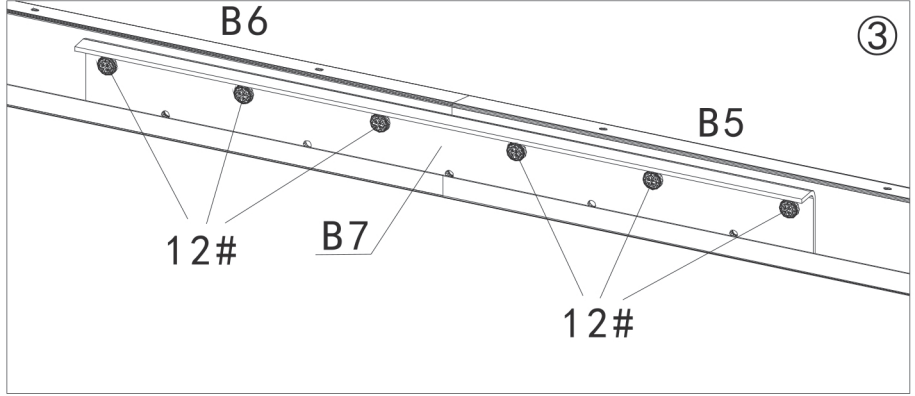
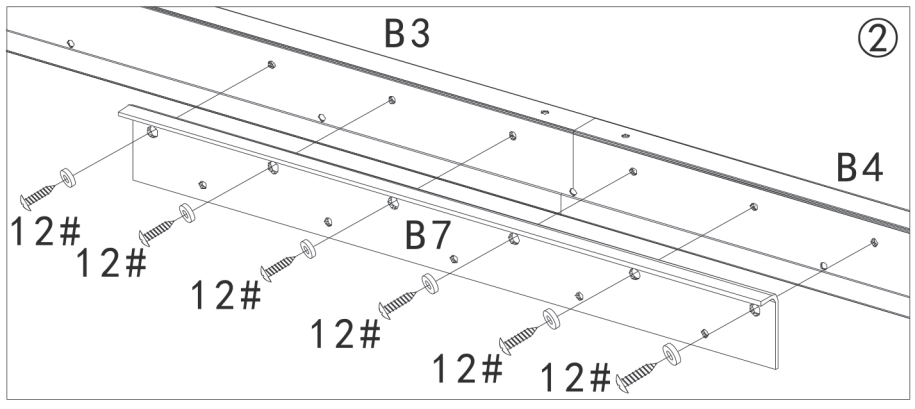
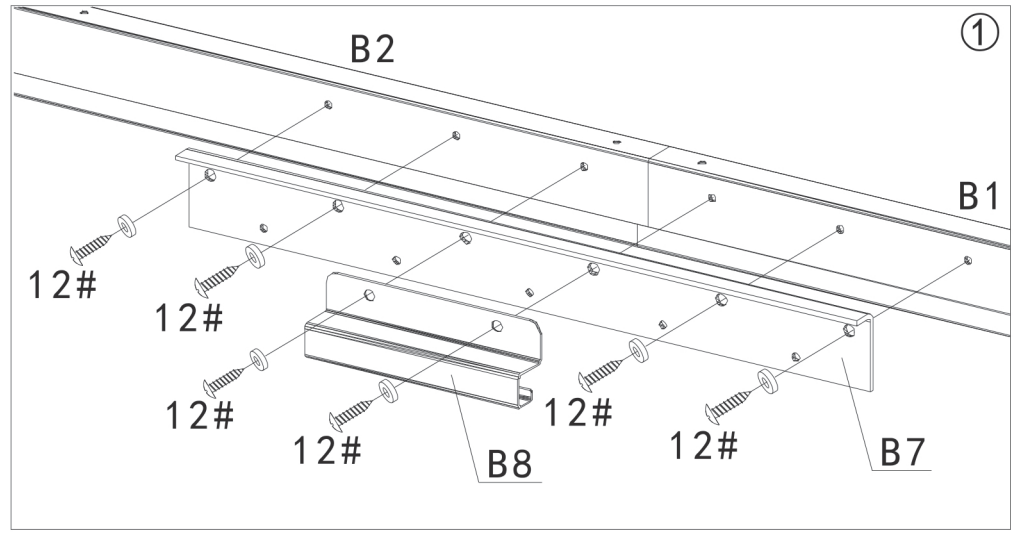

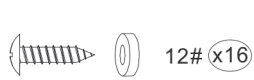

Enclose with part #B5/B3, part #B4/B6, part #B5/B2, part #B1/B6, according to the figure above, and the part #B connects the four corners, then fixed with 16 screws 12# and gaskets as shown in ①②.

Fix 2 part #C4 on part #B1, part #B2 by 4 screws 9#, gaskets as shown in ③④.

**!** You can also install the top frame on each wall separately.

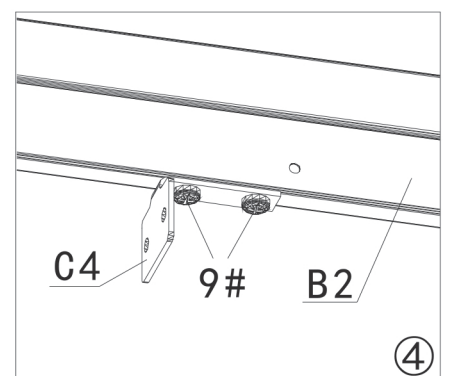
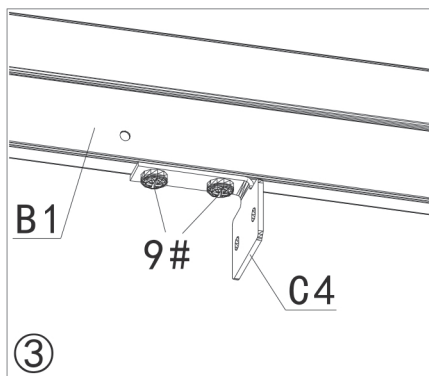
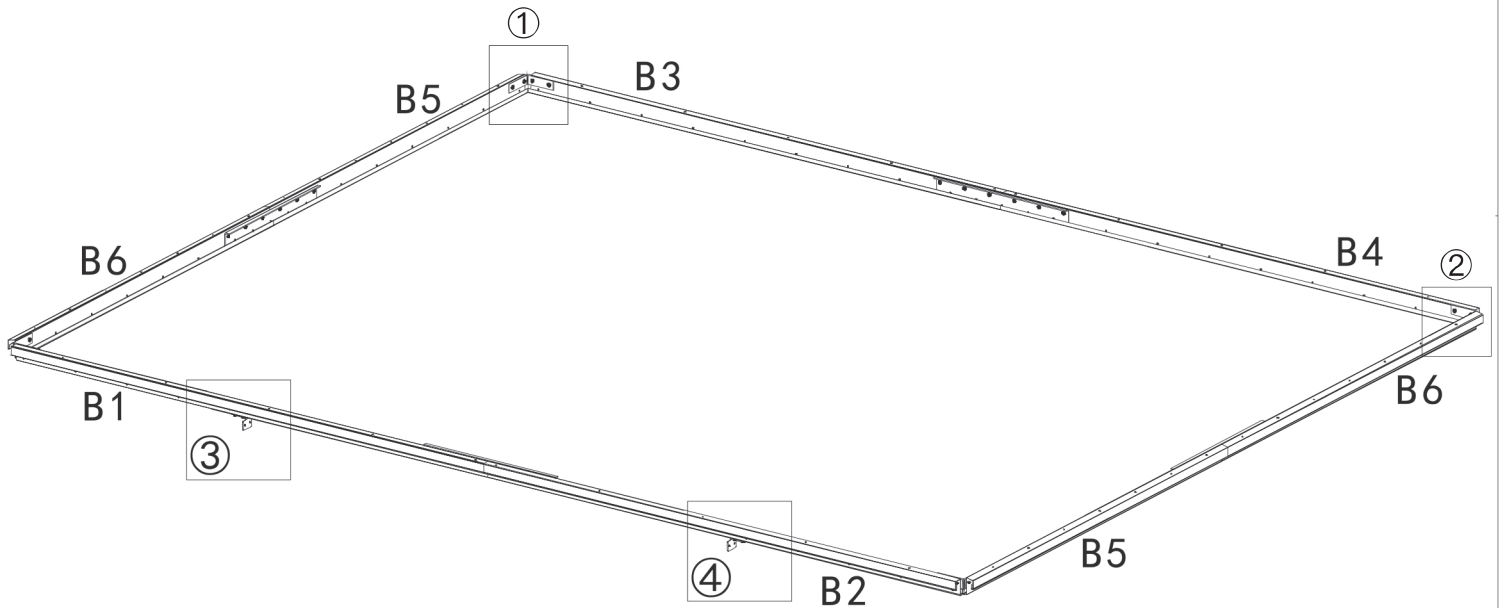
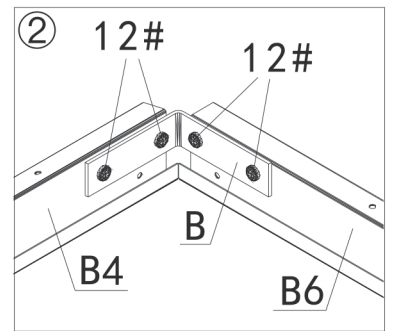
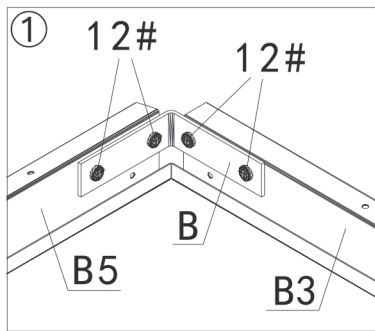

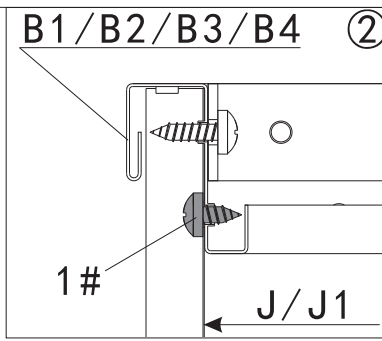
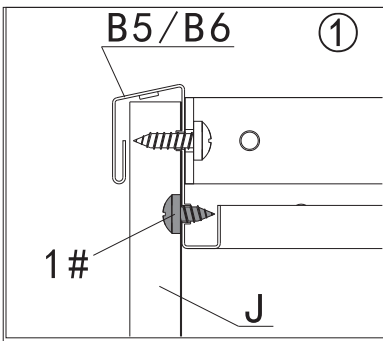

Place the assembled beam (B1,B2, B3,B4,B5,B6) on the upper end of the wall panel, and fix with 75 screws 1# and gaskets as shown in ①②.

Fix the upper end of the part#C1/C2 with part#B1 and part#C4 by using screws 3#, the nuts and gaskets are on the back side as shown in ③④.

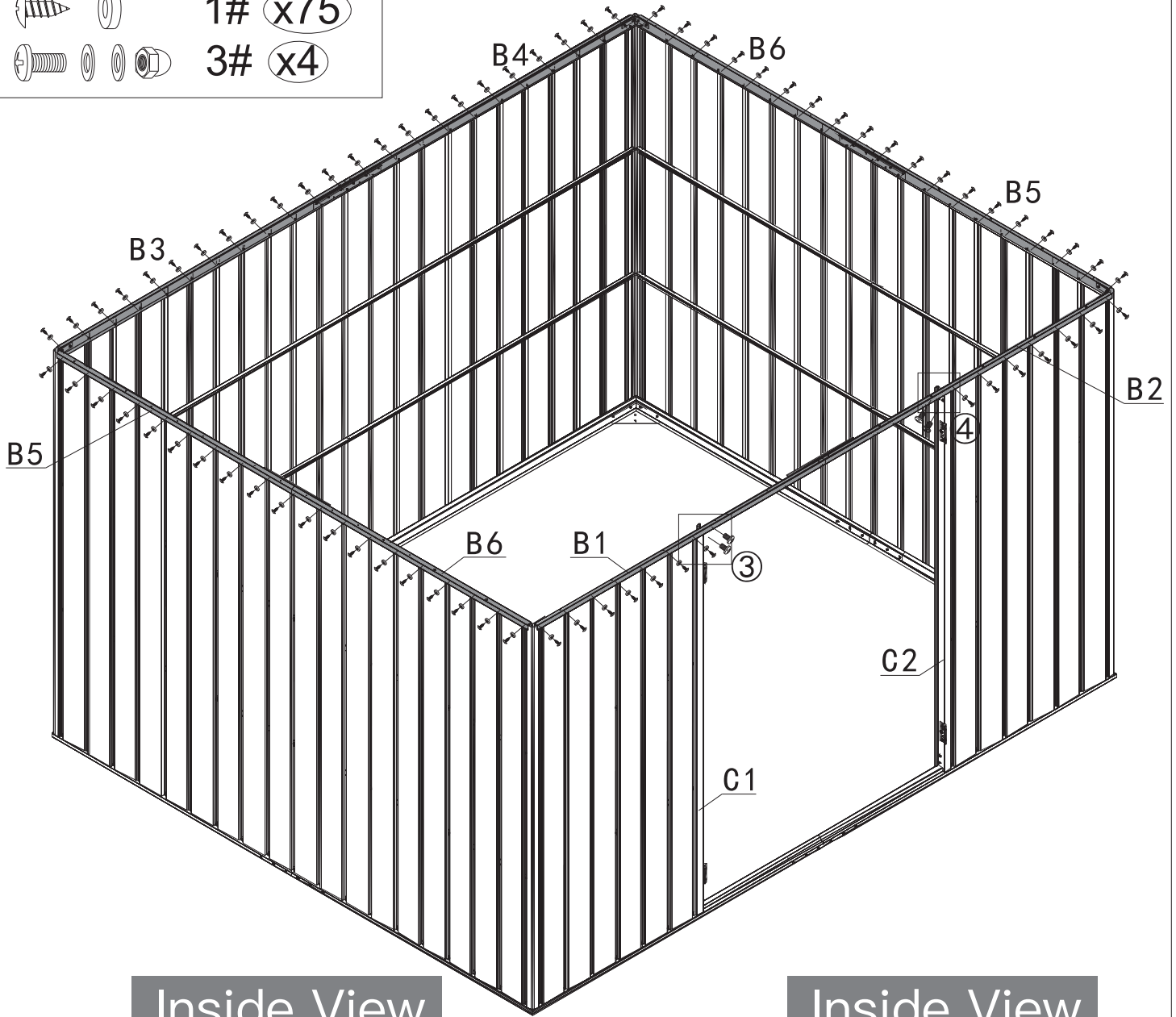
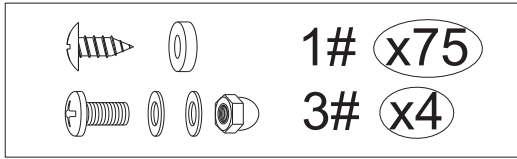

Inside View

Inside View

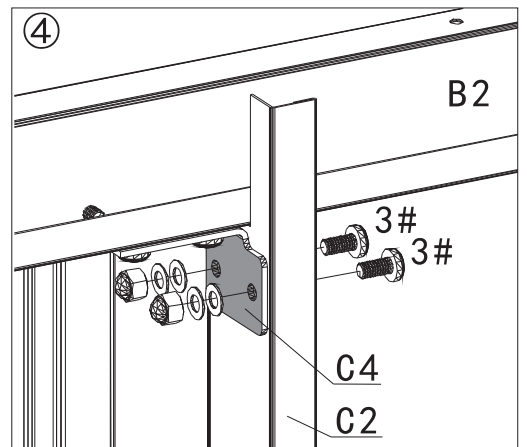
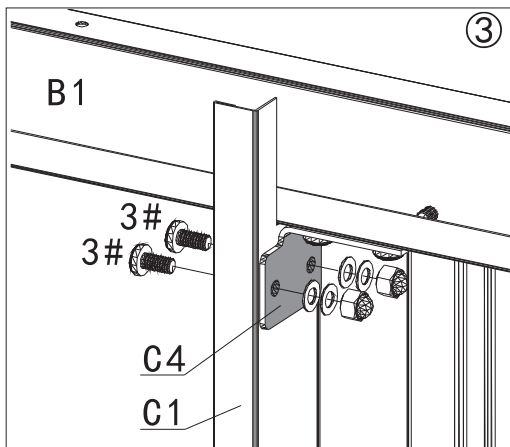

- |   |  |         |  |         |  |          |
|---|--|---------|--|---------|--|----------|
| 1 |  | E1 (x2) |  | E2 (x2) |  | 9# (x24) |
| 1 |  | E3 (x2) |  | E4 (x2) |  | 3# (x24) |
|   |  | E5 (x4) |  | E6 (x1) |  | 6# (x12) |

Connection of the part #E1\*2/E2\*2/E5\*2/E6

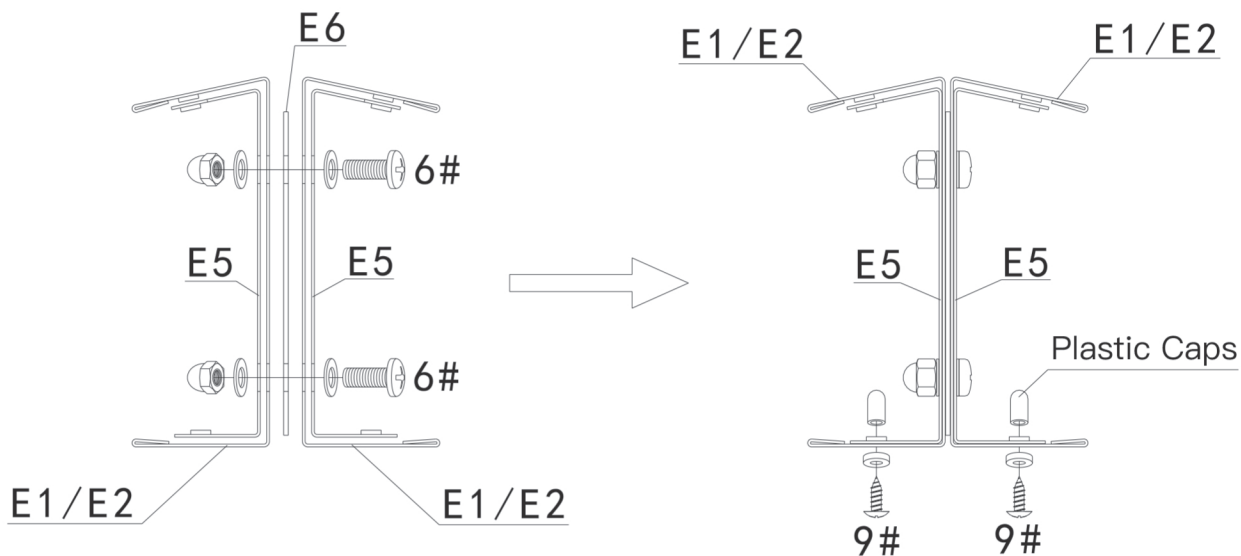
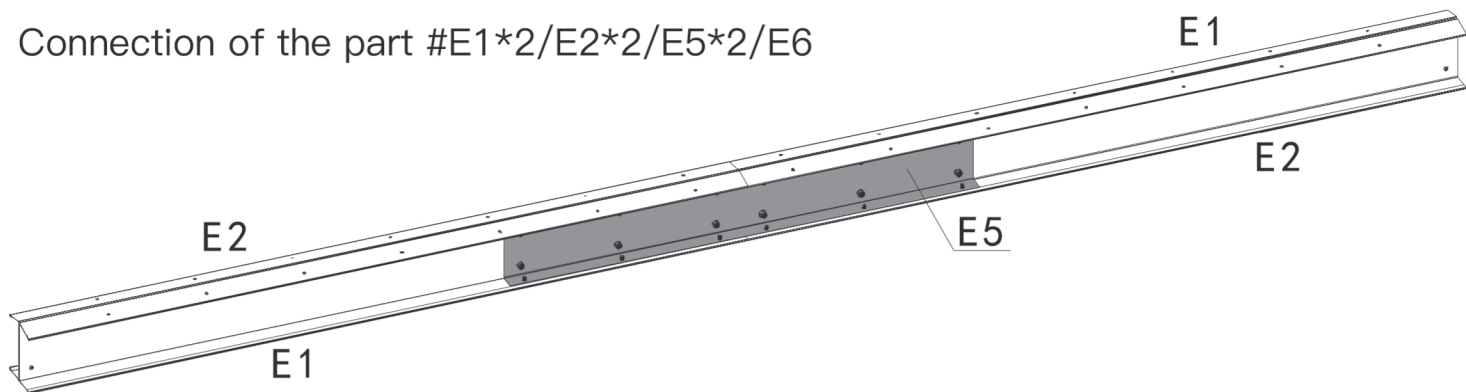

Connection of the part #E3/E4/E5

(X2)

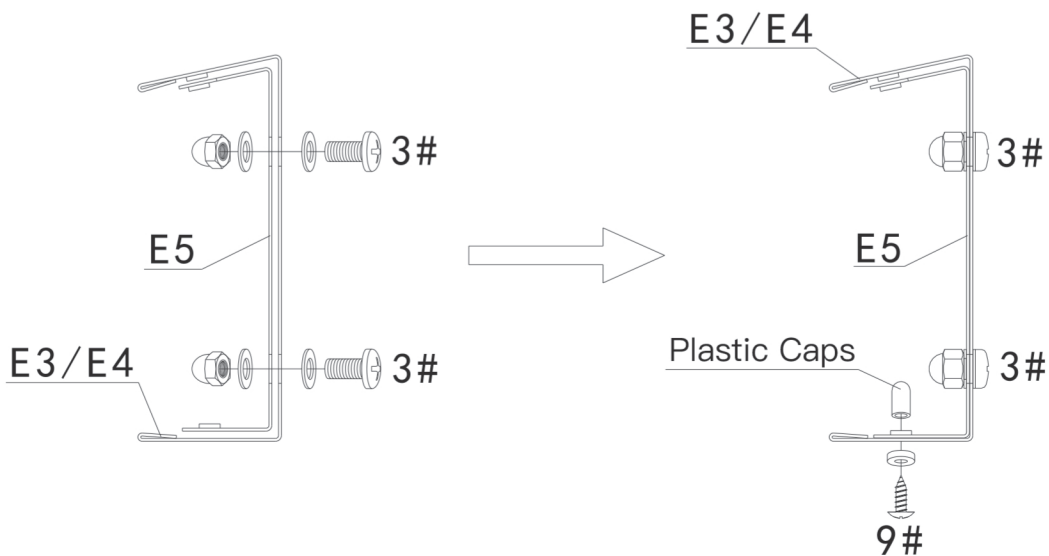
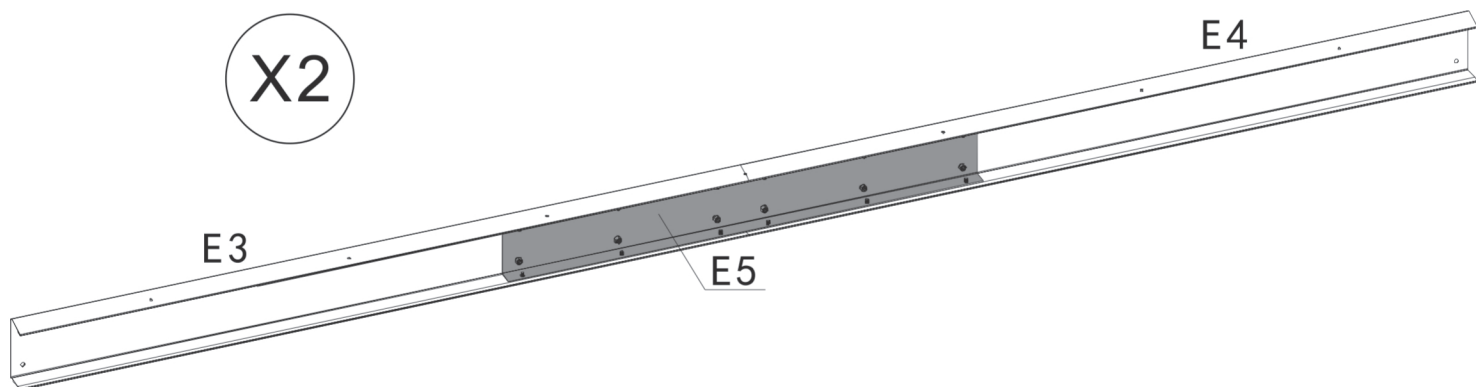

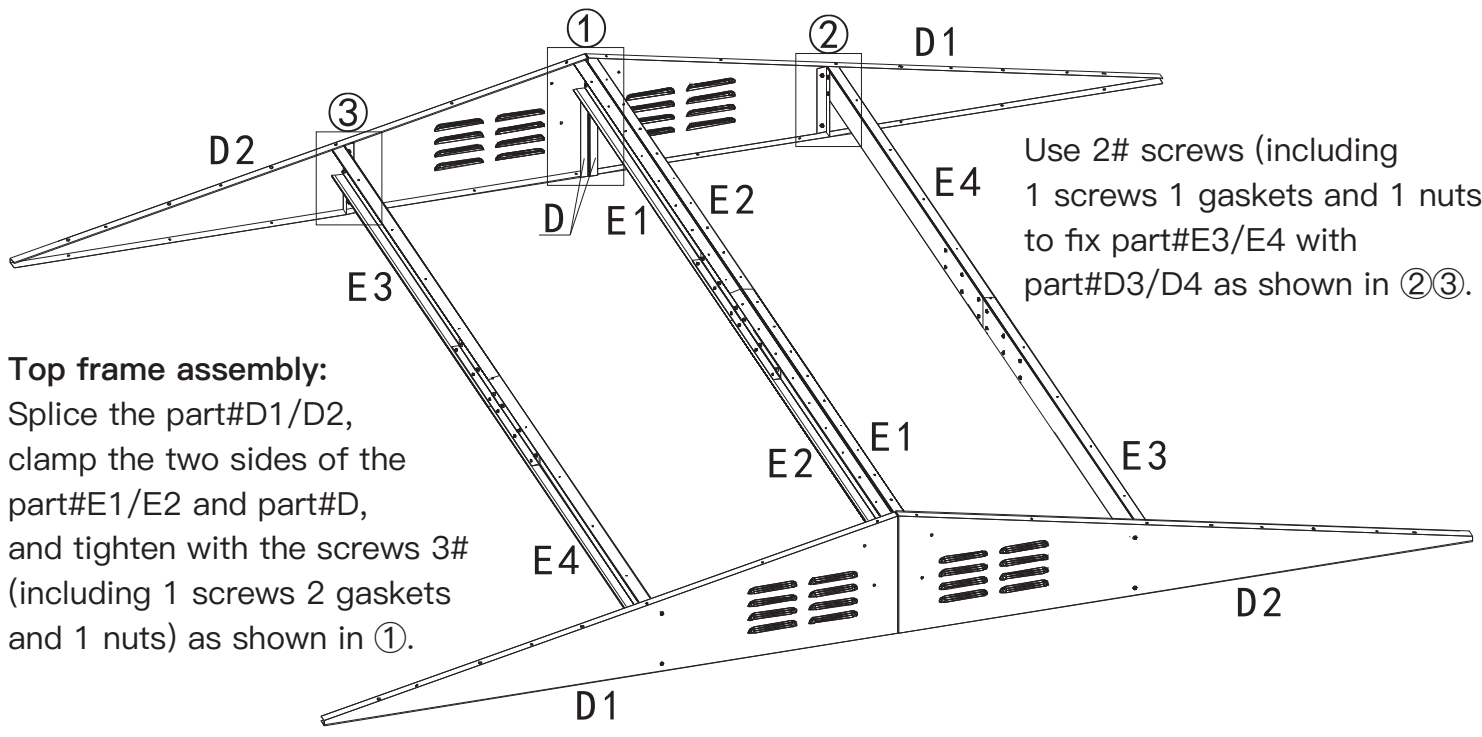
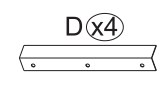
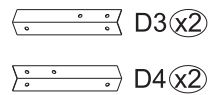
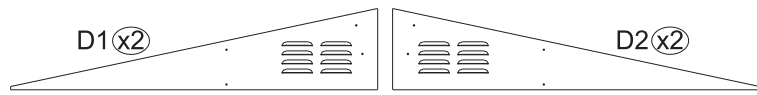

Use 2# screws (including 1 screws 1 gaskets and 1 nuts) to fix part#E3/E4 with part#D3/D4 as shown in ②③.

**Top frame assembly:**  
Splice the part#D1/D2, clamp the two sides of the part#E1/E2 and part#D, and tighten with the screws 3# (including 1 screws 2 gaskets and 1 nuts) as shown in ①.

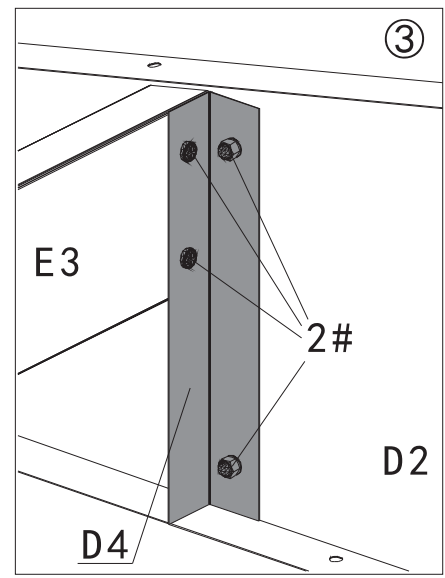
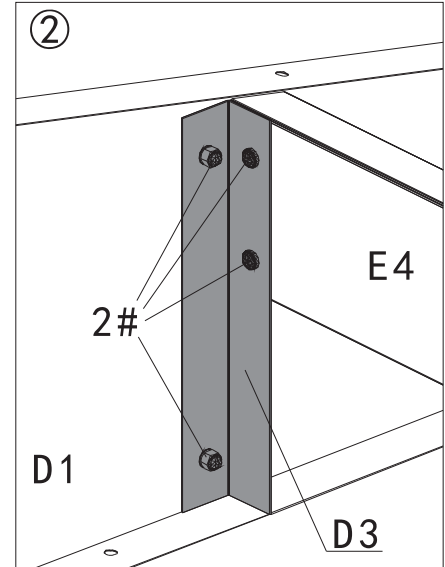
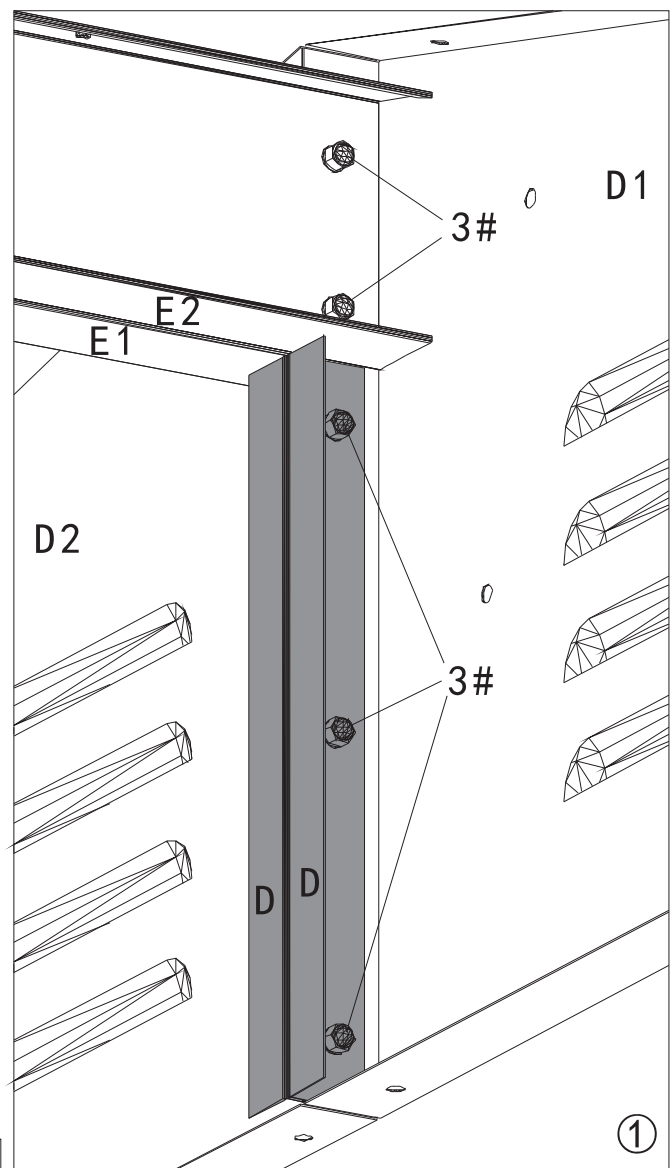

1# (x24)

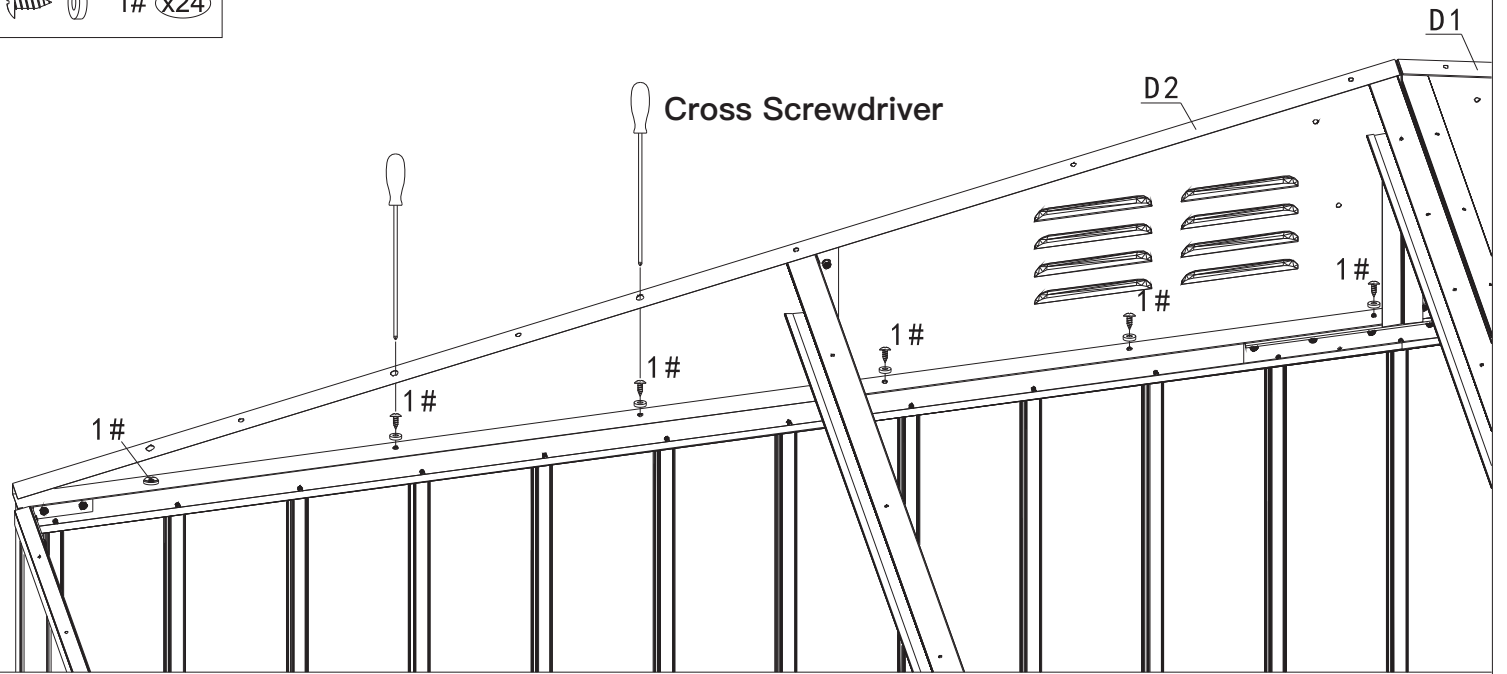

Put the top frame on beam(#B1 & #B2 & #B3 & #B4), use 24 screws and gaskets #1 to fix.

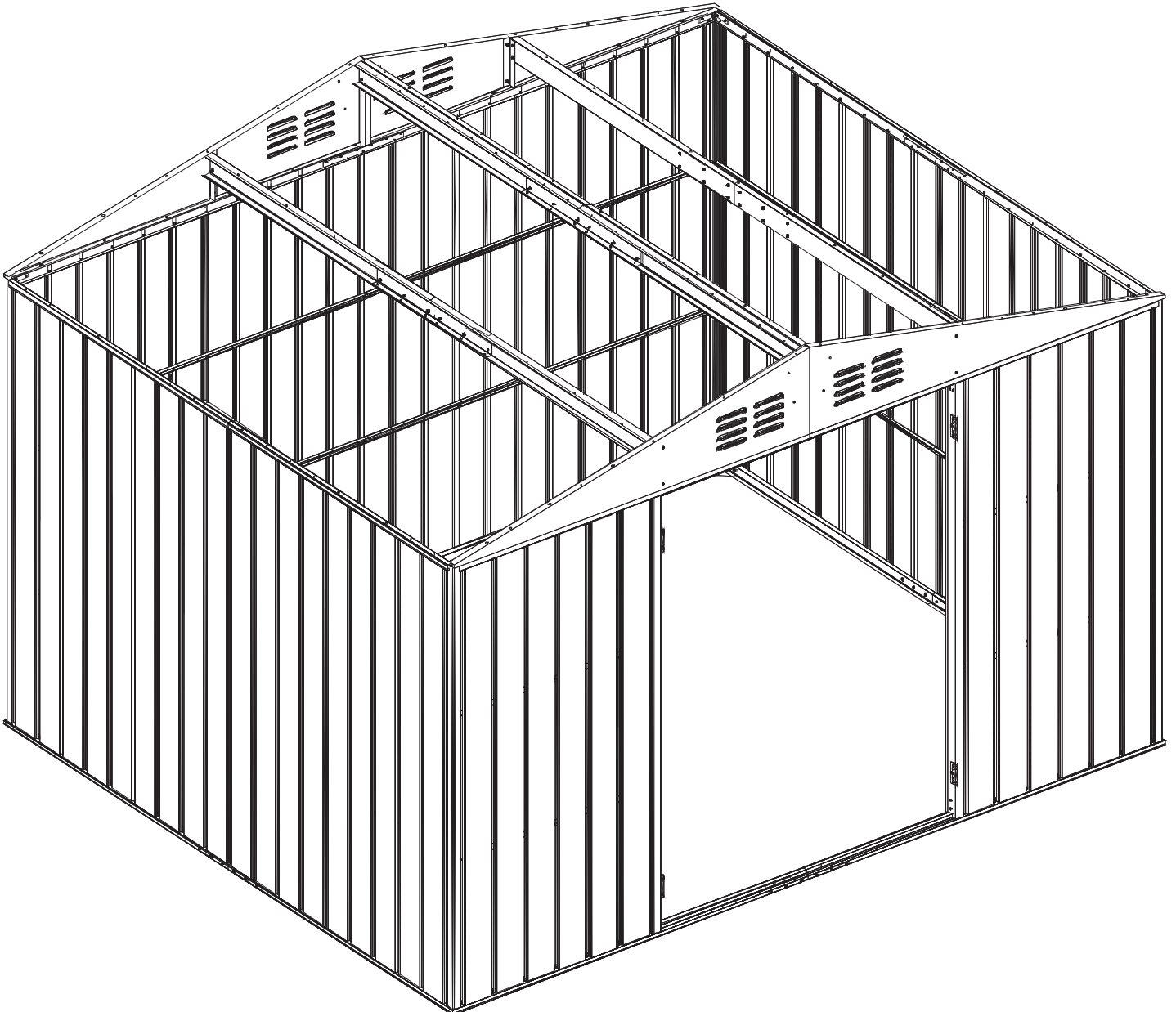

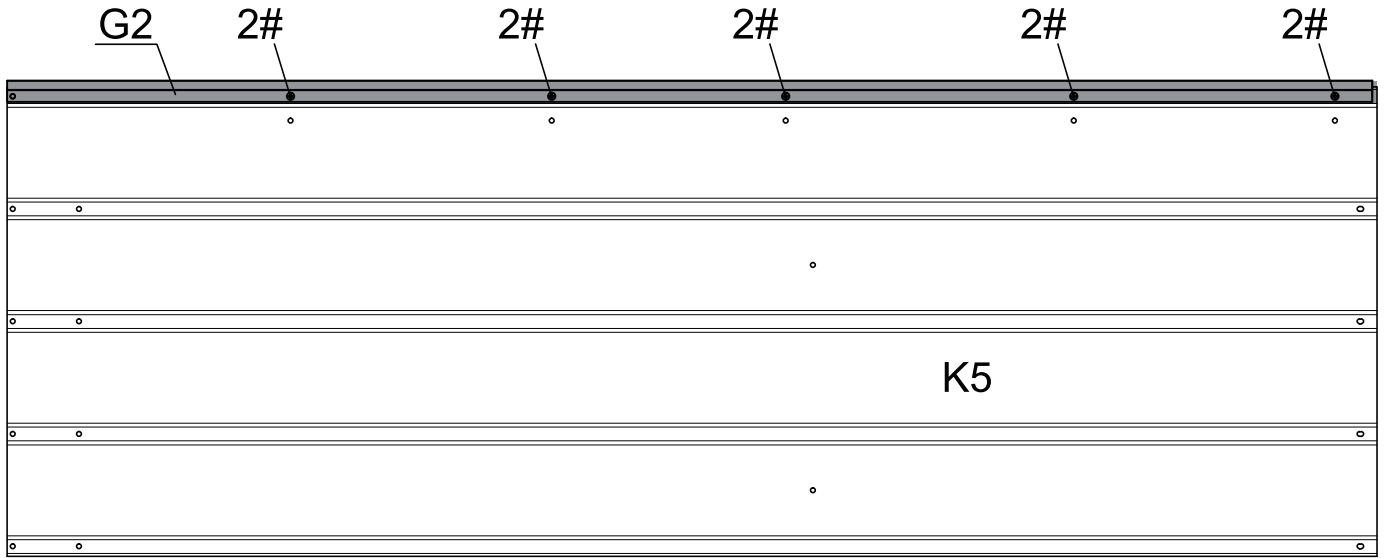
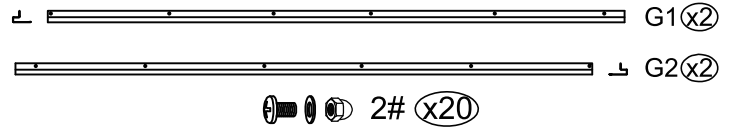
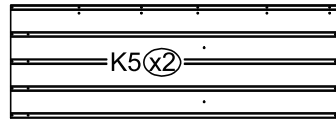
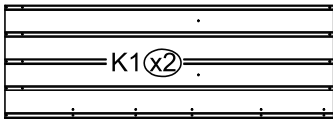

X2

Assemble the part#G2 to the one side of part#K5 with 5 screws 2# gaskets and nuts.

Assemble the part#G1 to the one side of part#K1 with 5 screws 2# gaskets and nuts.

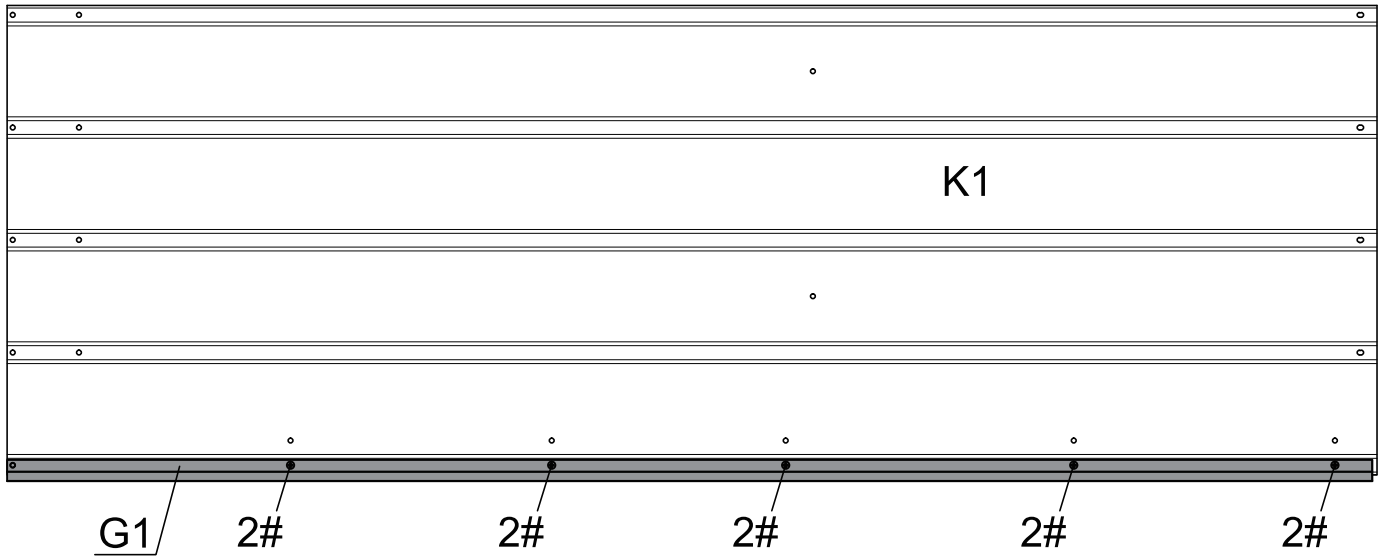

X2

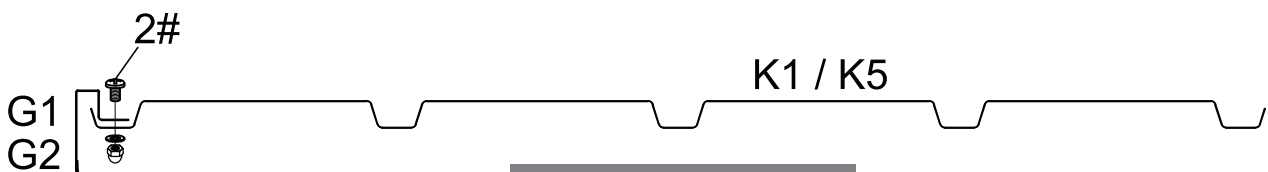

Section View

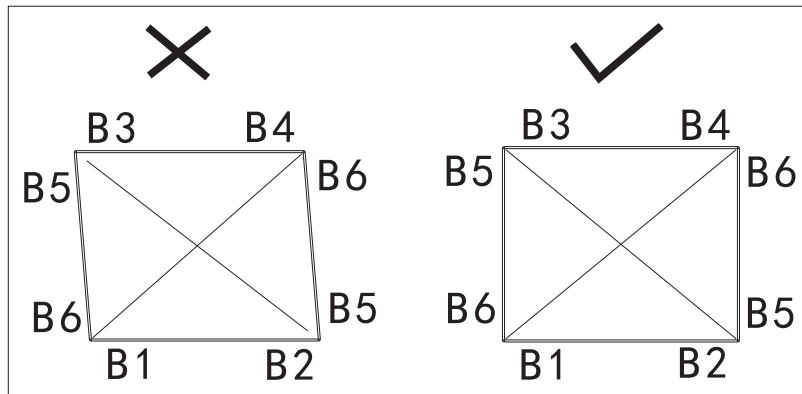

Attention: The top plate can be installed in order or reverse order. If there is a deviation between the top plate and the top frame installation hole, it is generally caused by the diagonal size deviation of the frame beam. The diagonal distance of the frame beam can be measured and adjusted.

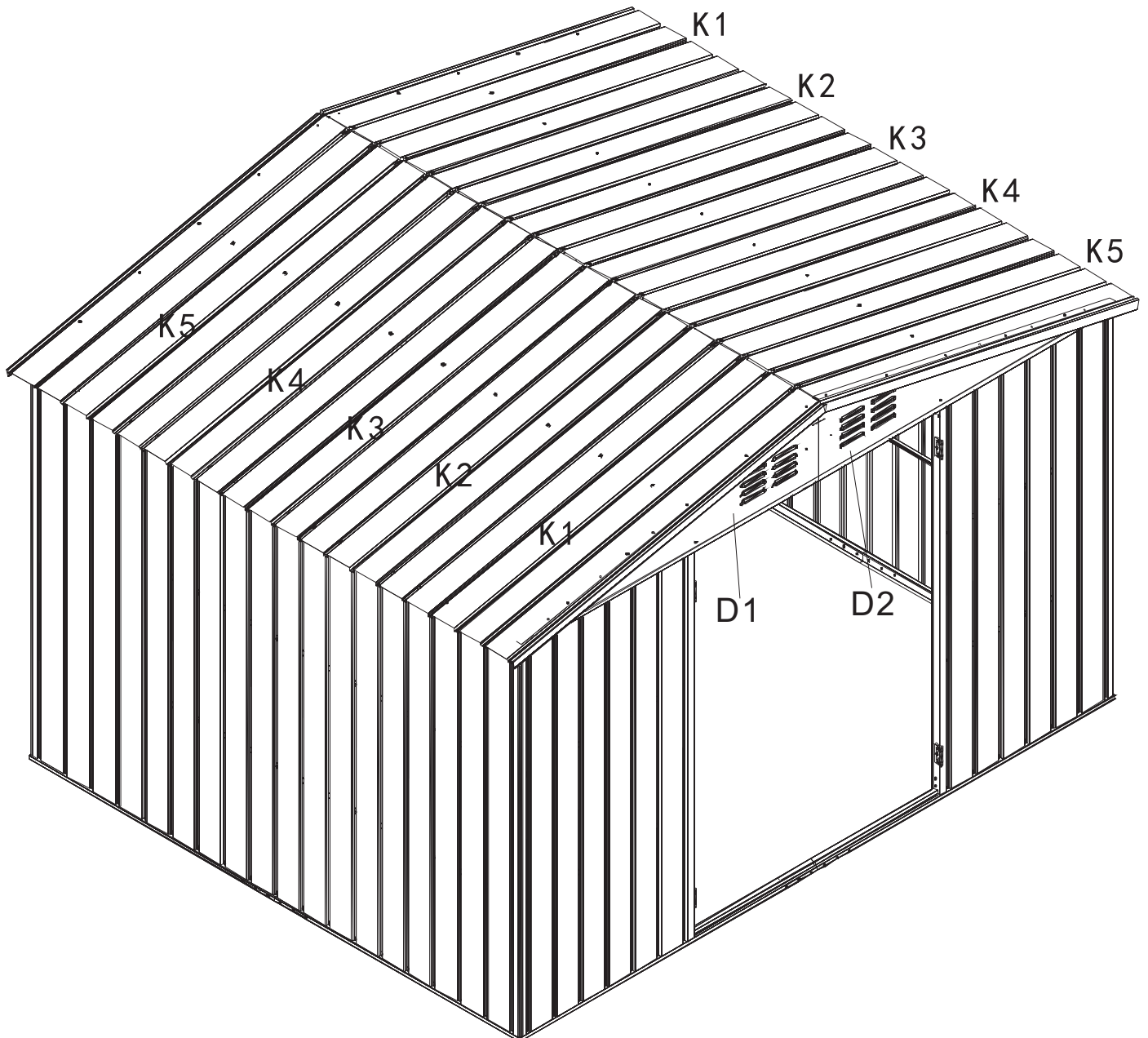

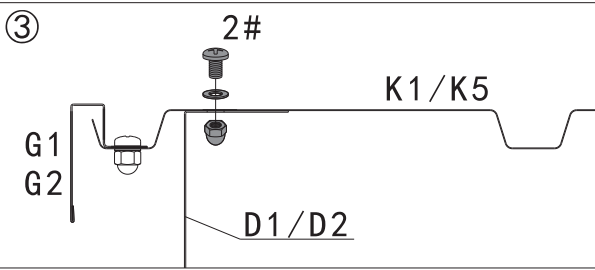
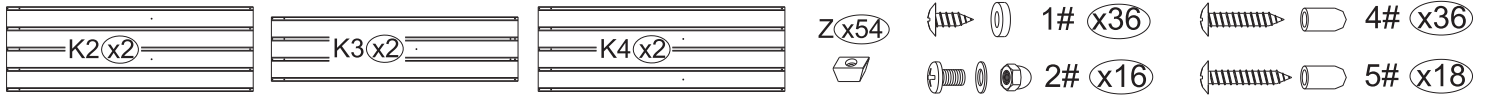

Part #Z shall be inserted at the fixed position of top beam and top roof groove to prevent rainwater intrusion.

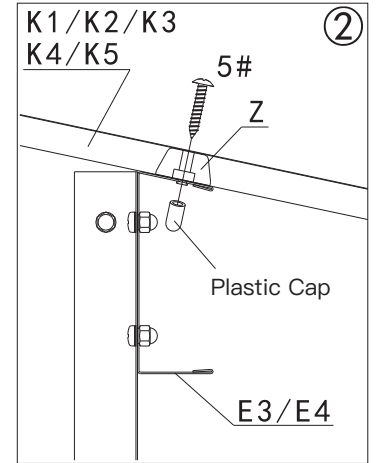

The roof panel K1/K5 is fixed with top frame D1/D2 by using screws 2#, gaskets and nuts as shown in ③; then fix with screw 1# and gaskets to side frame beam as shown in ④.

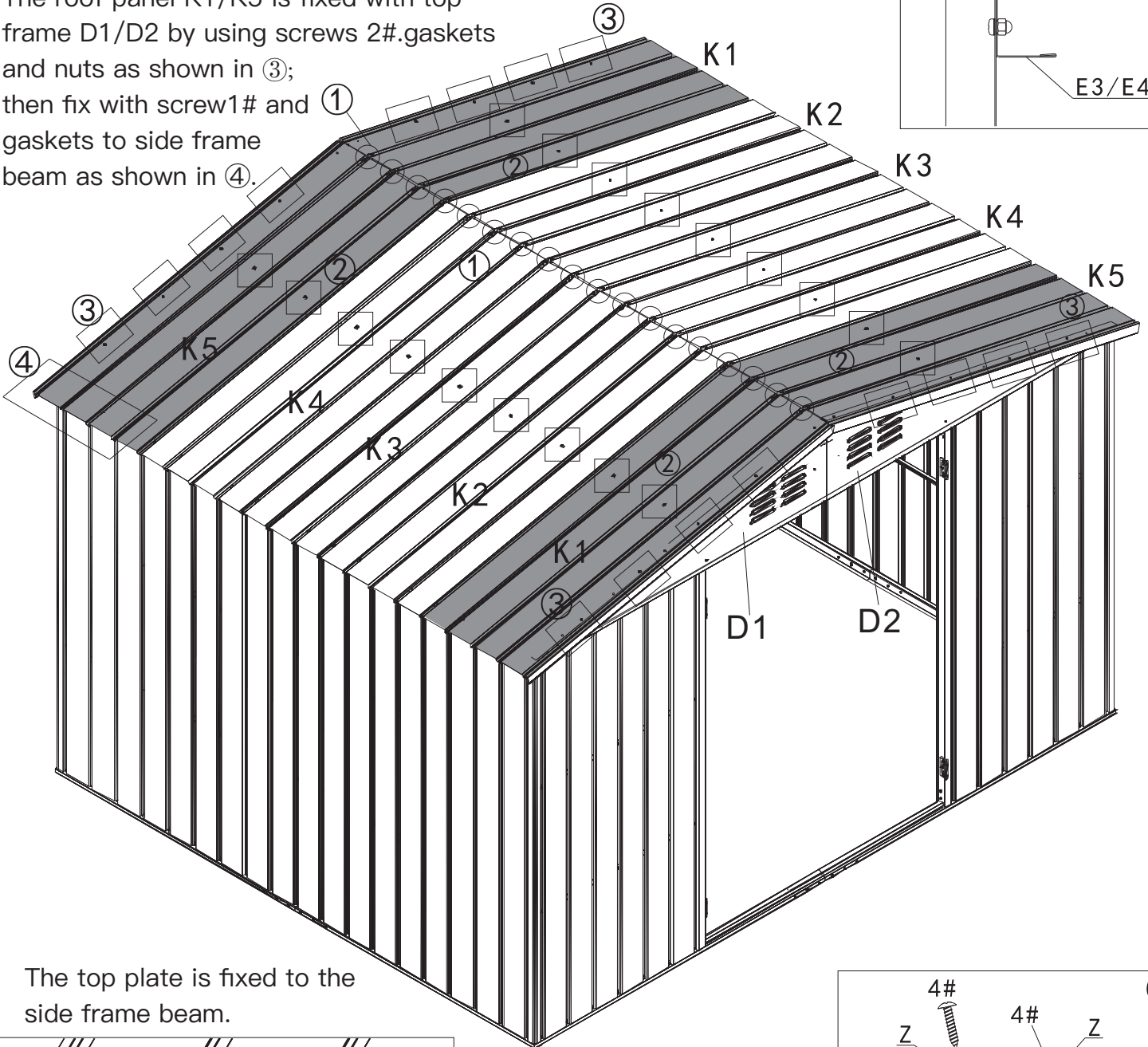

The top plate is fixed to the side frame beam.

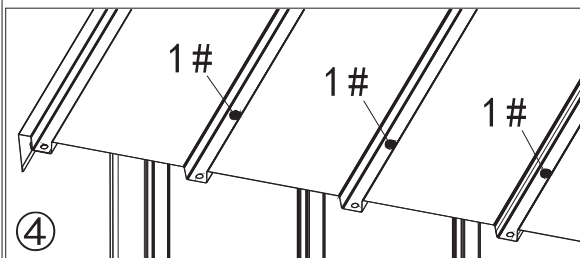

Secure the top plate to the top beam with self-tapping screw 4# and part #Z as shown in ①

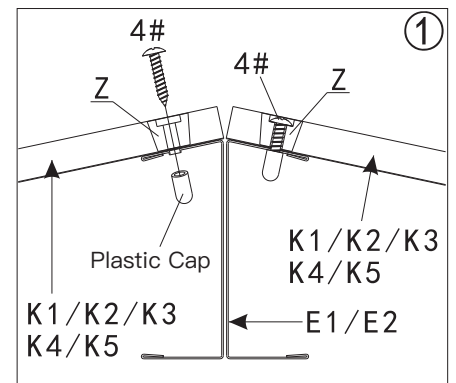

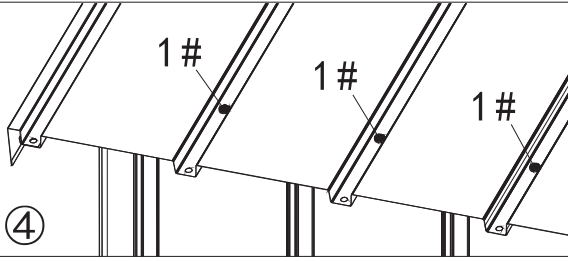
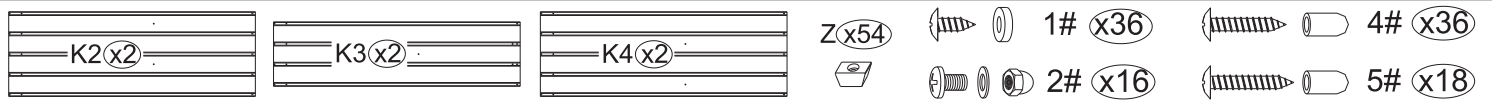

▲ Part #Z shall be inserted at the fixed position of top beam and top roof groove to prevent rainwater intrusion.

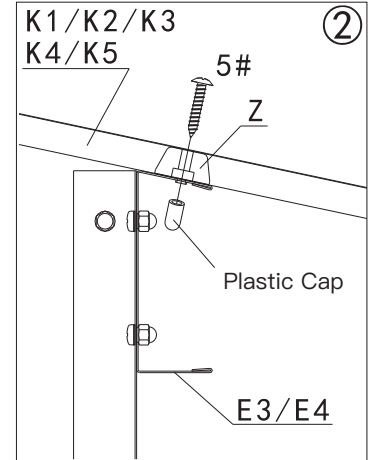

Fix the roof panel K4/K3/K2 by using screws 2# gaskets and nuts as shown in ②, then fix with screw 1# and gaskets to side frame beam as shown in ④.

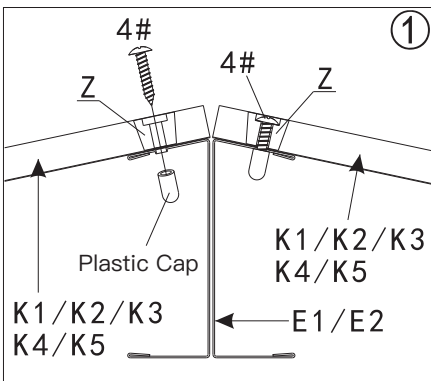
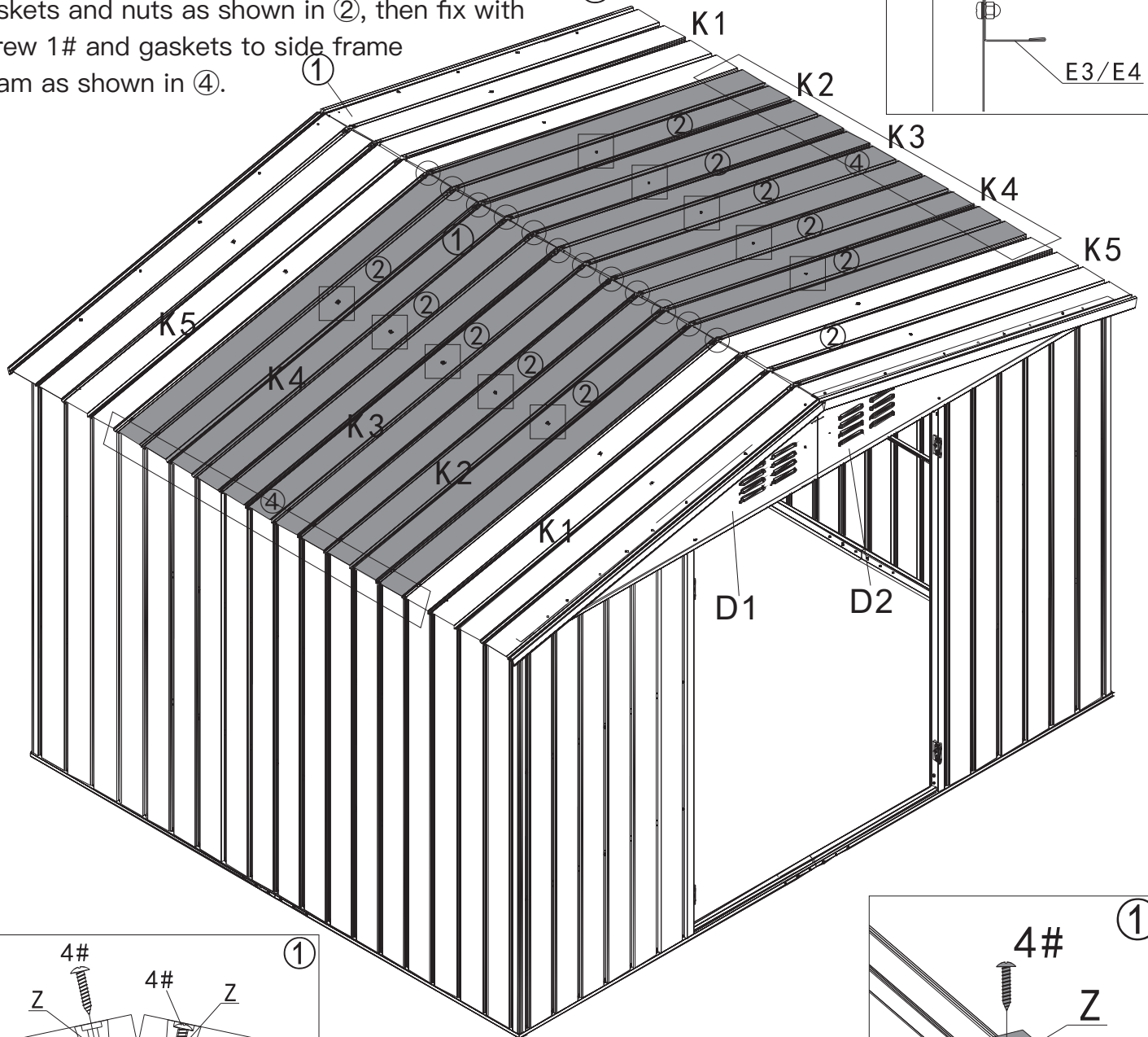

Secure the top plate to the top beam with self-tapping screw 4# and part #Z.

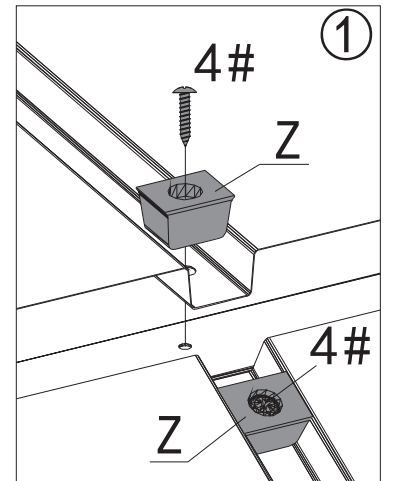

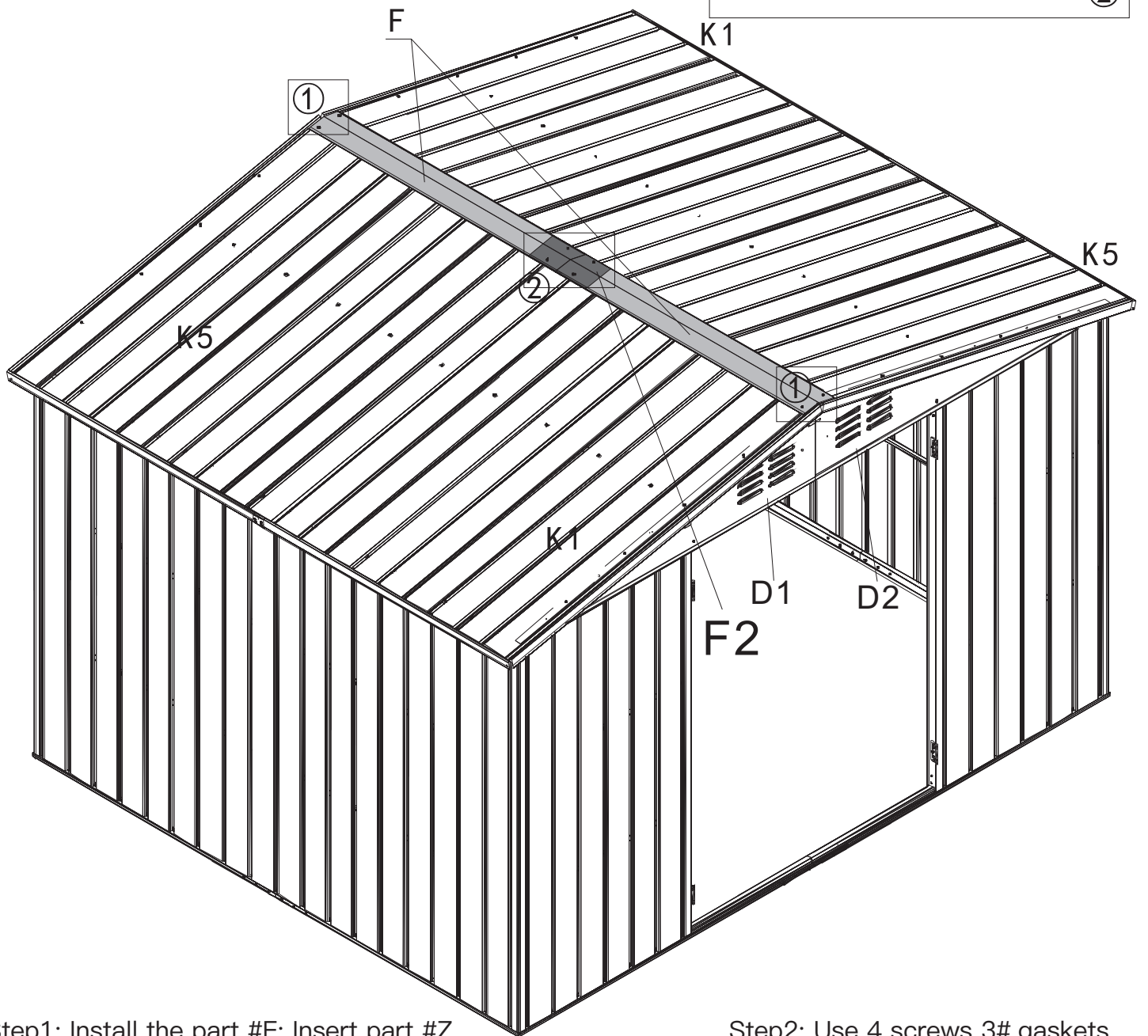
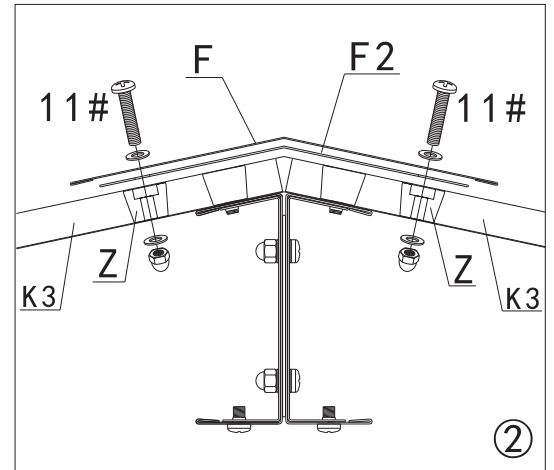
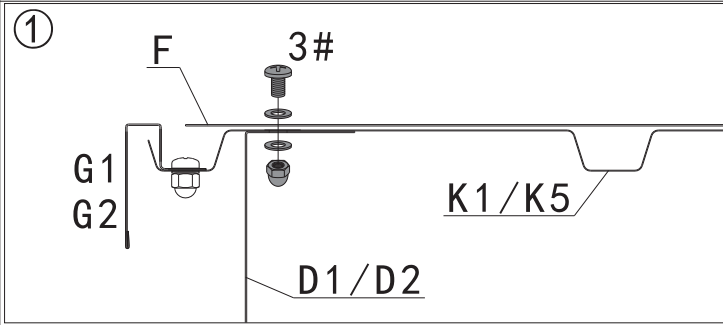

**Step1:** Install the part #F: Insert part #Z into the top panel groove, use 4 screws 11#, gaskets and nuts to fix part#F2 and part #F on the roof top.  
(part #F should cover on part#F2) as shown in ②.

**Step2:** Use 4 screws 3#,gaskets and nuts to fix the 2 sides of part #F with part #K1/K5 and part #D1/D2 as shown in ①.

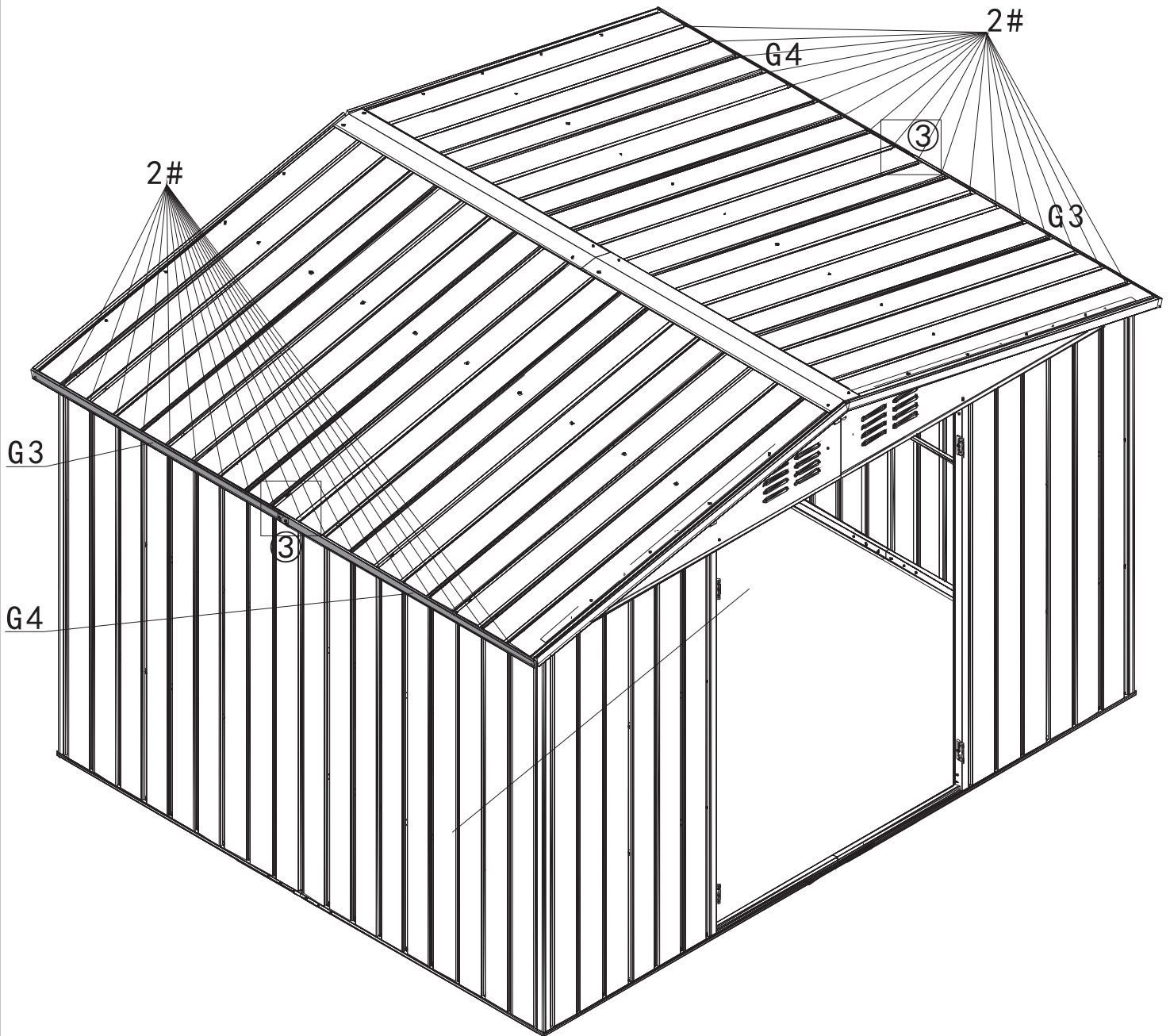

**Step1:** Use 18 screws 2# gaskets and nuts to fix part #G3 and part#G4 on the cornice of top roof. Use 4 screws 2#,gaskets and nuts to cover part #G7 on the connection of part #G3 and part#G4 as shown in ③. Repeat the above producers to assemble the another side.

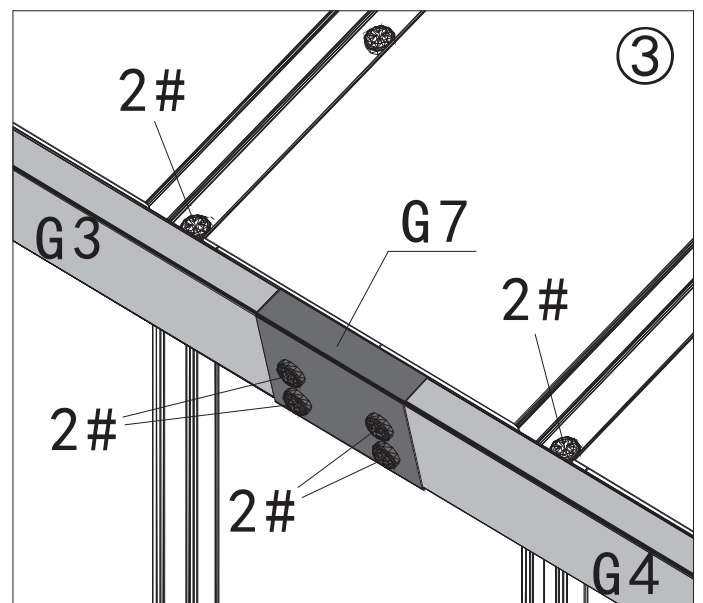

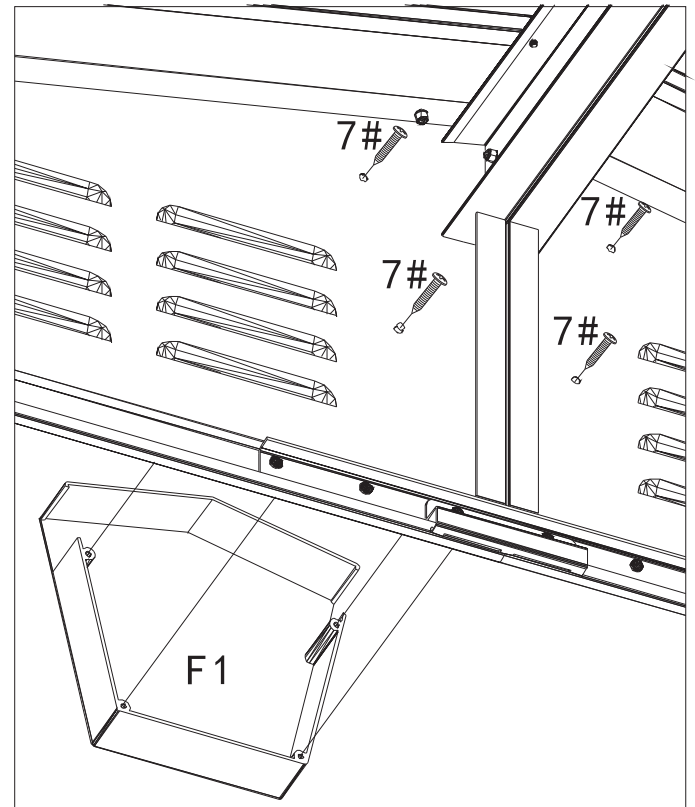
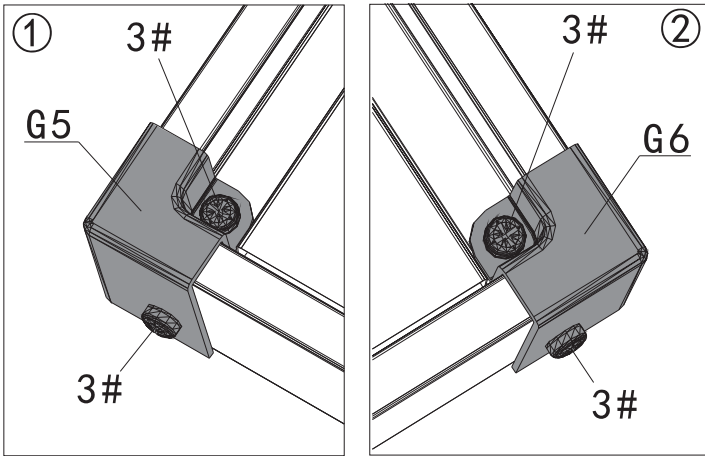

Install the part #G5/G6 with 8 screws 3#, gaskets and nuts as shown in ①/②.

Use 4 screws 7# to install the part #F1 from the inside.  
Repeat the above procedure to assemble the another side.

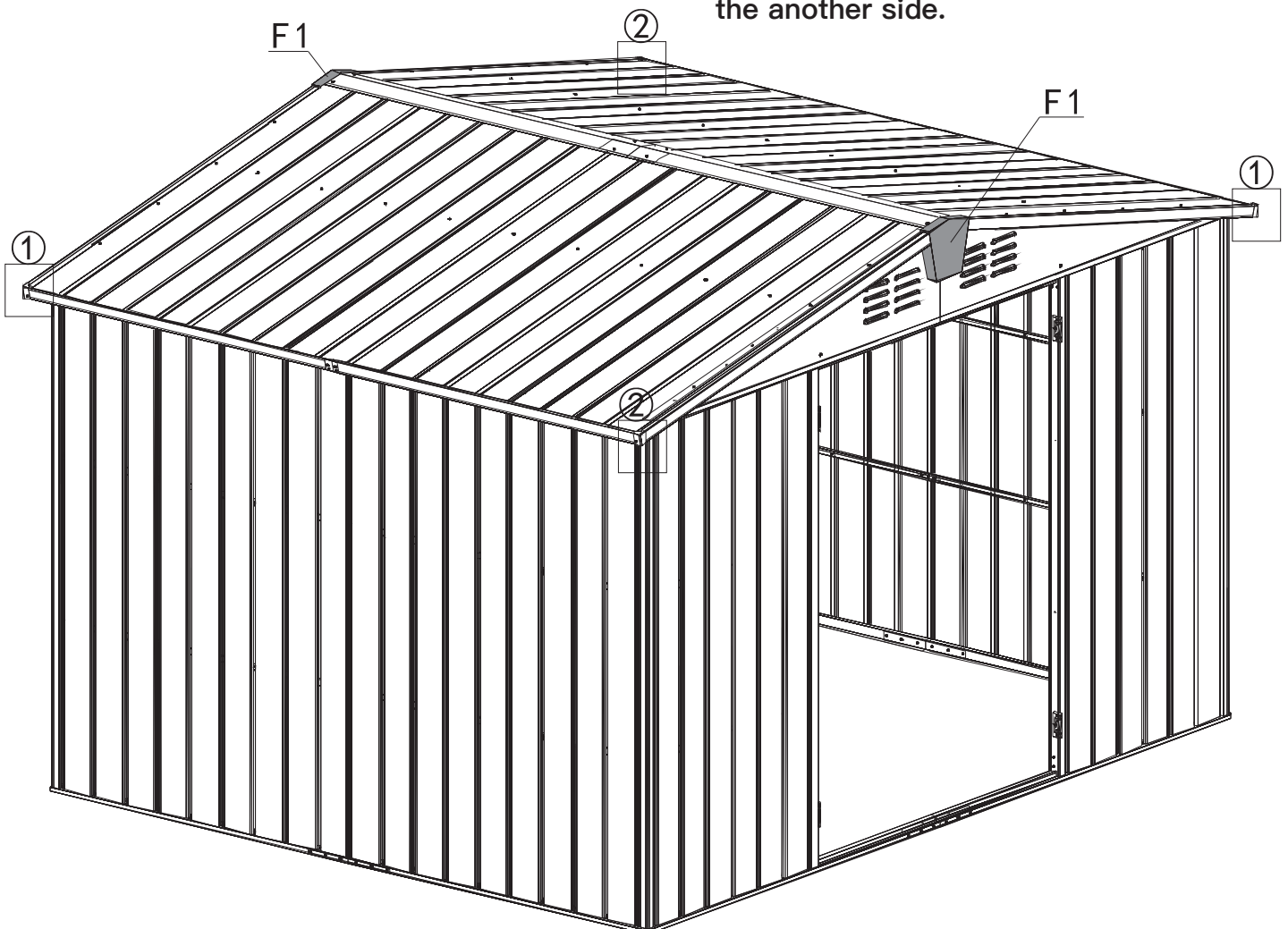

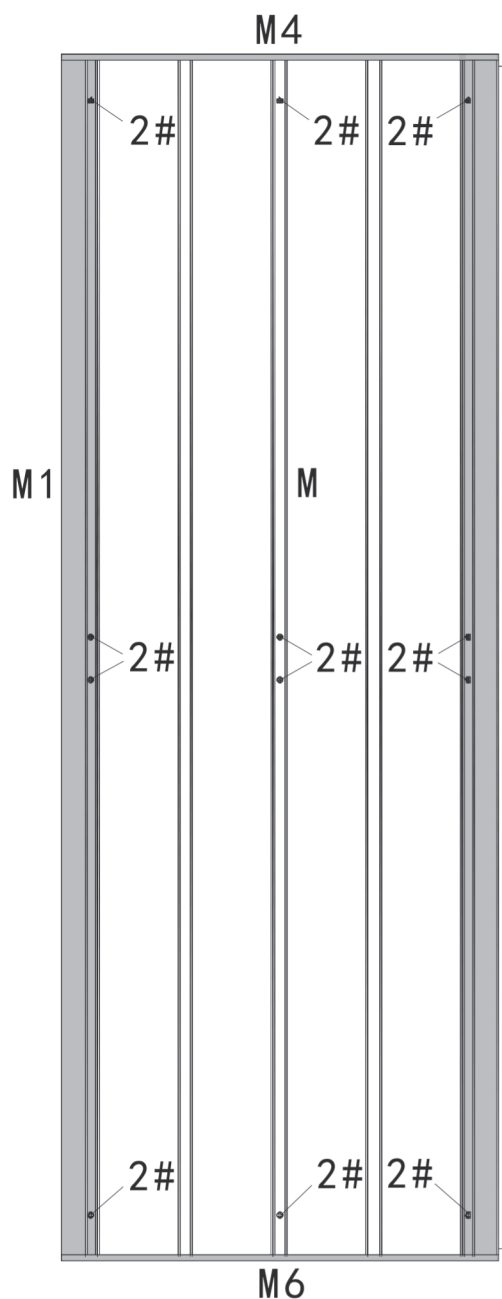
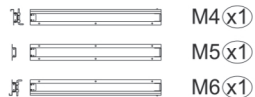
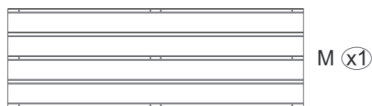

The front side of the left door



The back side of the left door

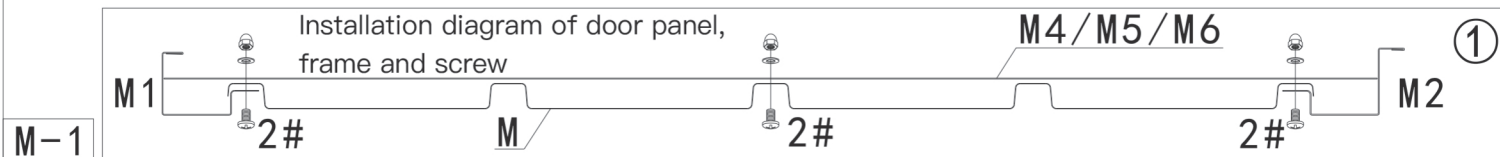
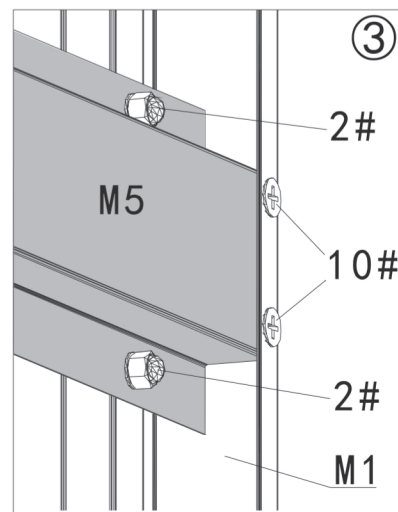
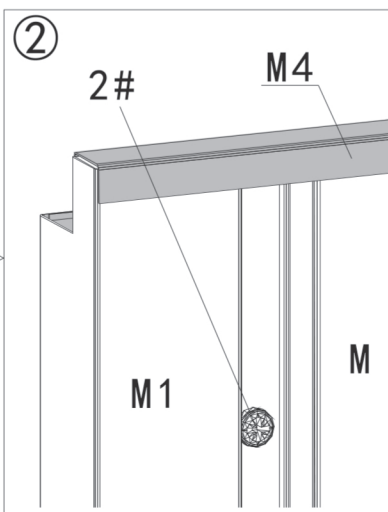
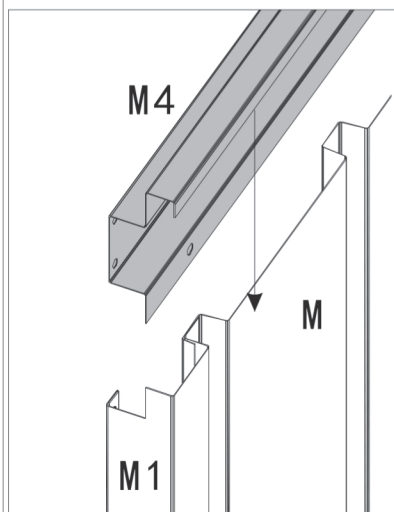

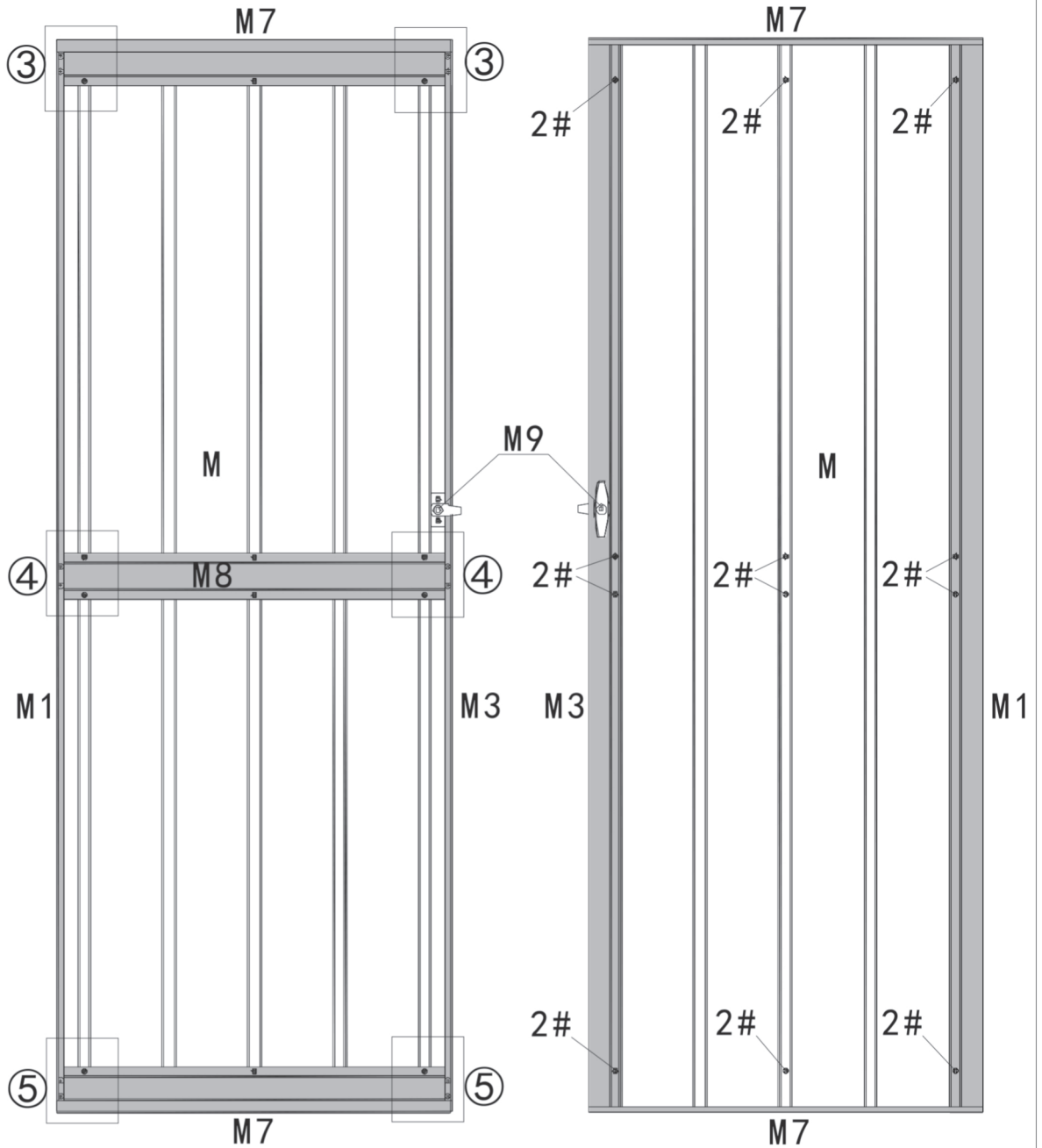
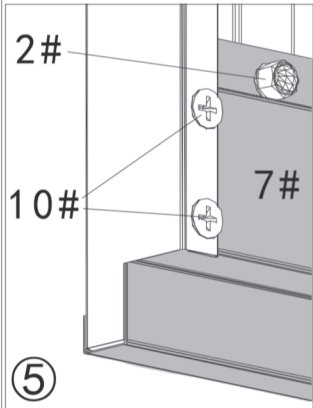
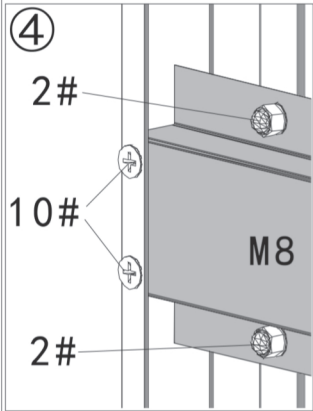
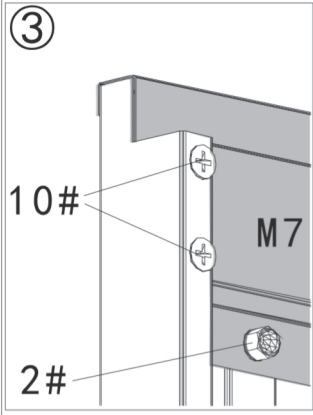
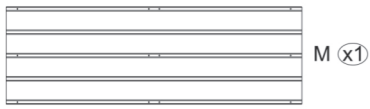

The back side of the right door    The front side of the right door

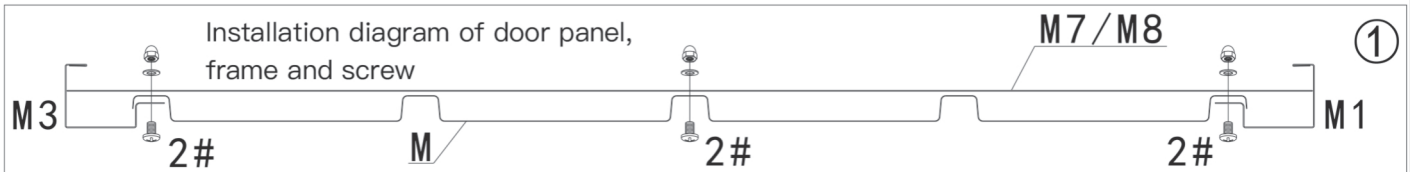
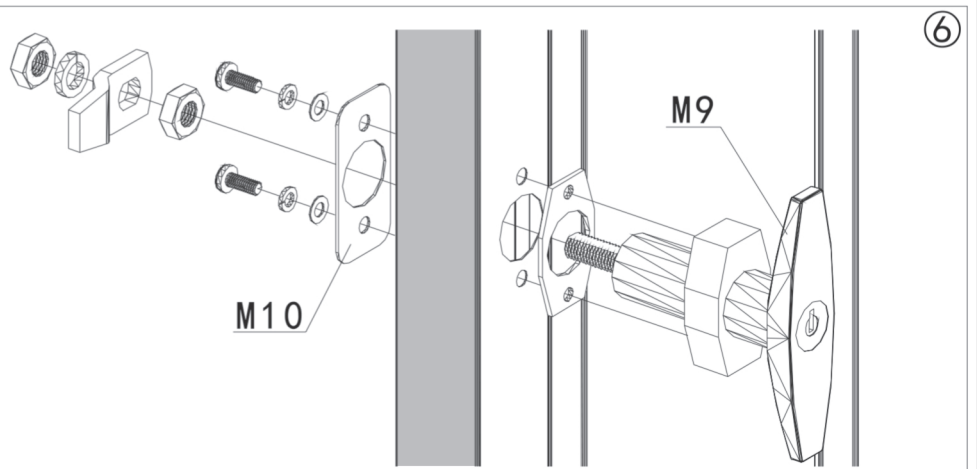
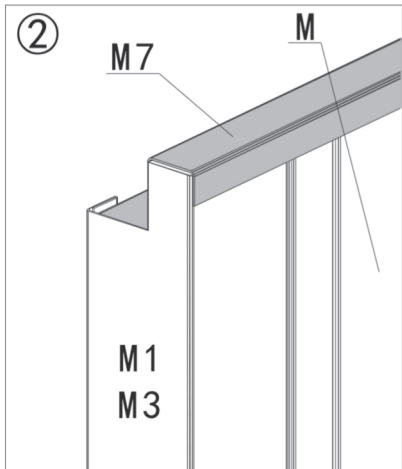

M-2

# How to Install the Door

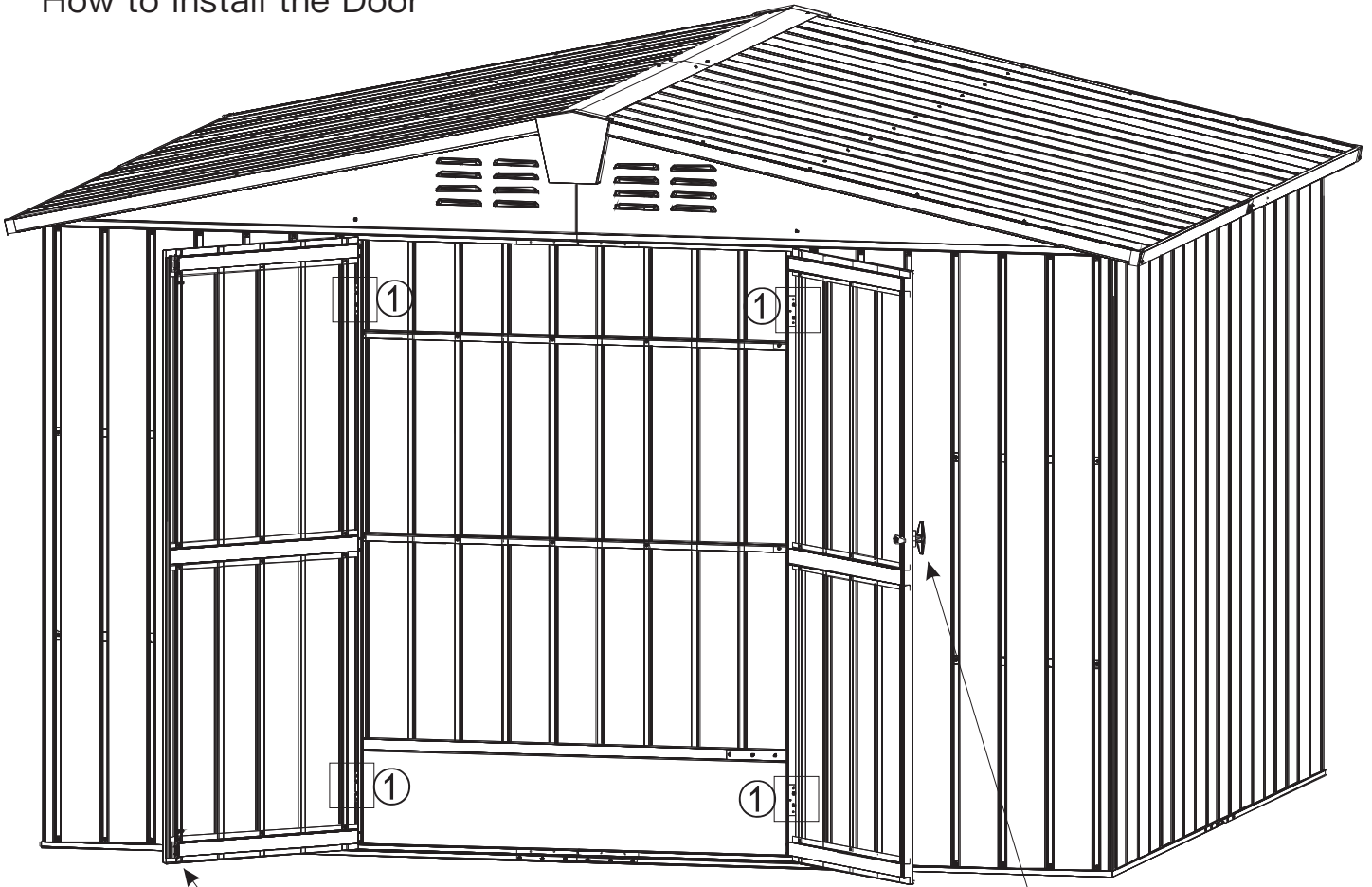

There is a bolt on the left door

There is a handle on the right door

This section is installed by the user.

The hinge has been pre-installed on the door frame C1/C2 by the factory.

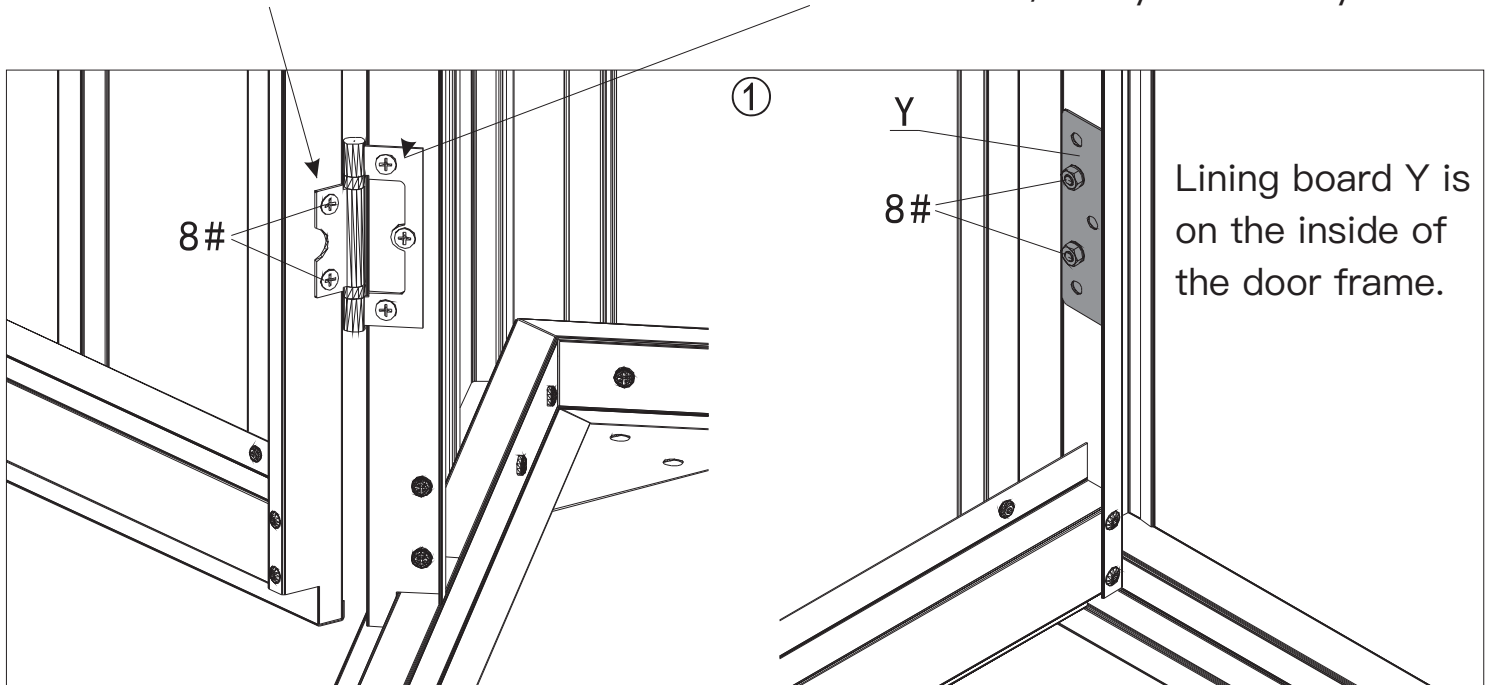

Lining board Y is on the inside of the door frame.

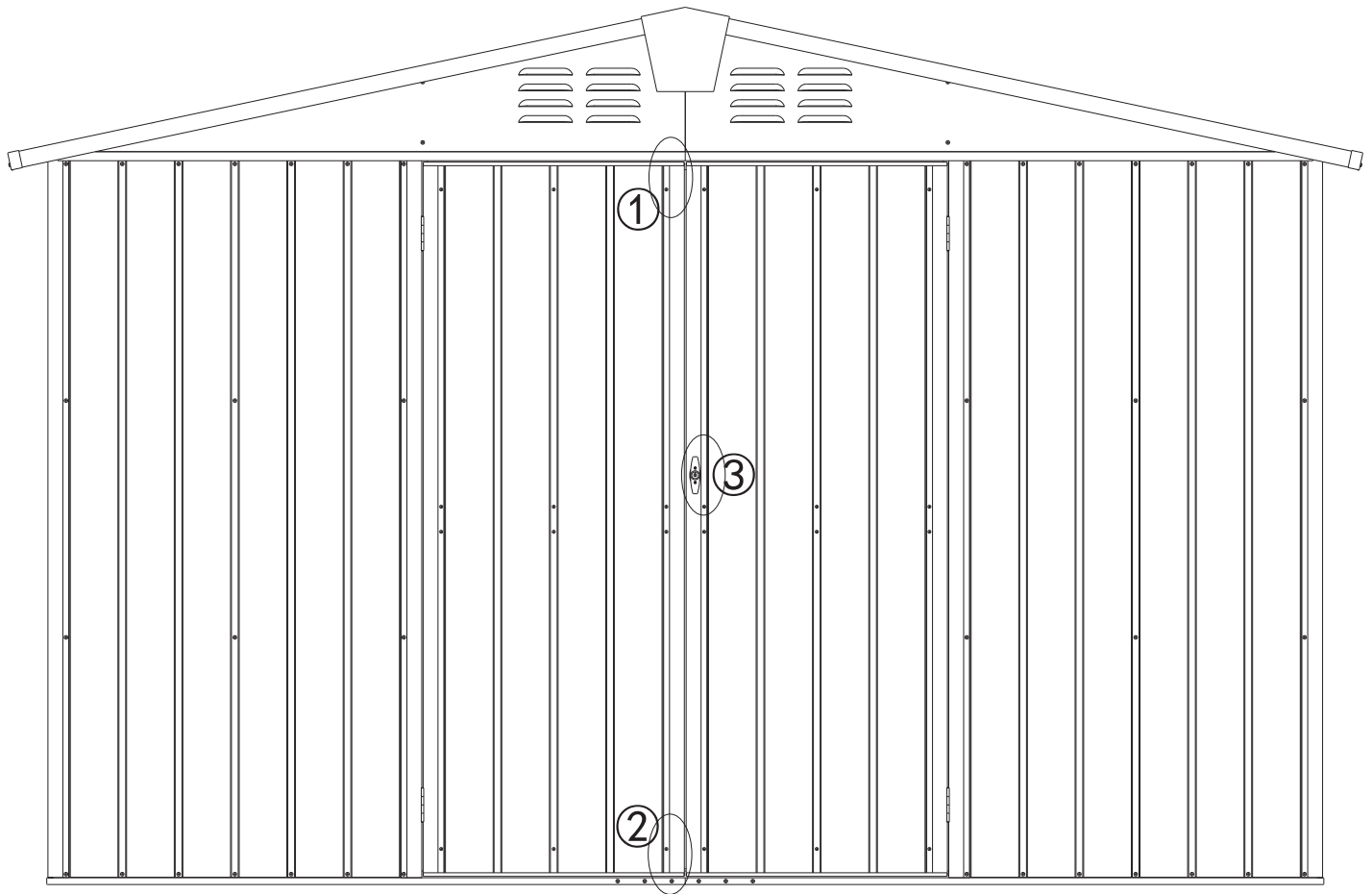

Insert the bolt and lock the left door.

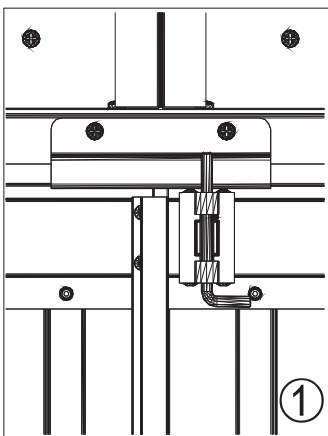

**Open the door:** insert the key, rotate 180 counterclockwise, and rotate the handle counterclockwise to open the door.

**Lock the door:** close the door, insert the key, rotate the handle clockwise, then rotate the key 180 clockwise and pull the key out.

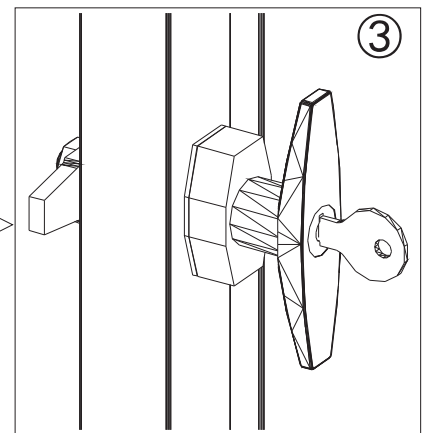
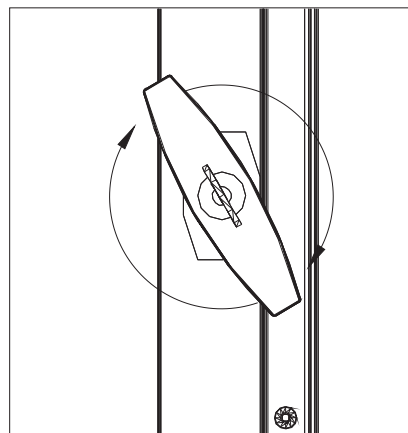
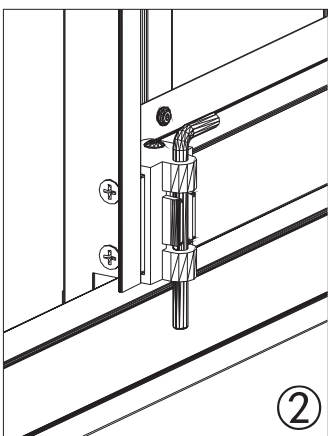

Insert the bolt and lock the left door.