

Hello Friend,



Thank you for being one of our customers. We love our customers, if you need us, we will always be here.

The chair comes with product warranty service. If there is any problem with the chair, please contact our after-sales service immediately, and believe that they will provide you with a satisfactory solution. If the chair meets your needs, welcome to share your feelings on Wayfair.

This assembly guide is equipped with installation instructions in four languages. To ensure that your assembly process goes smoothly, please follow the assembly instructions.

If you have any other problem, please contact us ASAP. We will provide you the best after sales services.

*Sincerely,
After-sales Service Team*

PRODUCT INSTALLATION GUIDE



SIZE:63*62*91.5(99.5)CM

Model: M76

User Manual

Installation and commissioning

1. Installation and commissioning.
2. Check whether the parts are complete and damaged.
3. Choose a spacious and clean site when assembling. Paper is laid flat on the ground to prevent parts from colliding with the ground during installation.
4. Use a soft flannel to remove the dirt on the furniture surface after installation. DO NOT wipe the furniture with a rag with gravel.



Pls read the Safety Instructions below carefully







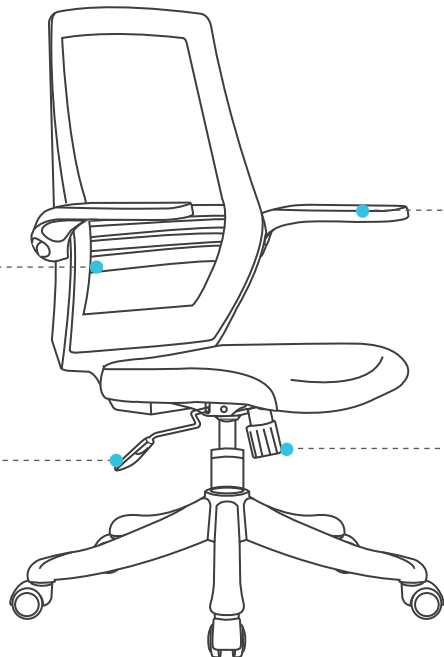



1. Please use on the flat floor and one chair can only bear one person's weight;
2. To avoid using the wrong screws, please fix all the screws before tightening them;
3. Please don't let the child sit on the chair alone if he is under 5 year-old;
4. Please don't sit on the armrest, in case cause some danger;
5. Do not stand on the chair or use it as a ladder or footsteps;
6. Please don't put overweight on the chair, or used as trolley;
7. Don't use sharp or hooked objects to scrape the chair and do not get it close to the fire;
8. To avoid any harm to your fingers, don't insert them into the mechanism while sitting.

Functions (The size will be according to regular practice)

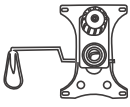
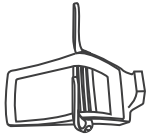

Rotate the handle to adjust the height Pull out the handle to adjust the backrest tilt Push in handle to lock backrest tilt

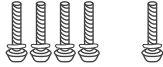
Parts list (The size will be according to regular measurements; One more as a backup)

			
Castor:5pcs	Base:1pc	Mechanism:1pc	Backrest:1pc
			Notice: Before installation, pls classify the screw, measure the screw length for easy assemble
Seat cushion:1pc	Gas lift:1pc	Hex wrench:1pc	
			
Backrest screw(M6*35):4+1pcs	Mechanism screw(M6*20):4+1pcs		

Assemble Introduction (The size will be according to regular measurements)

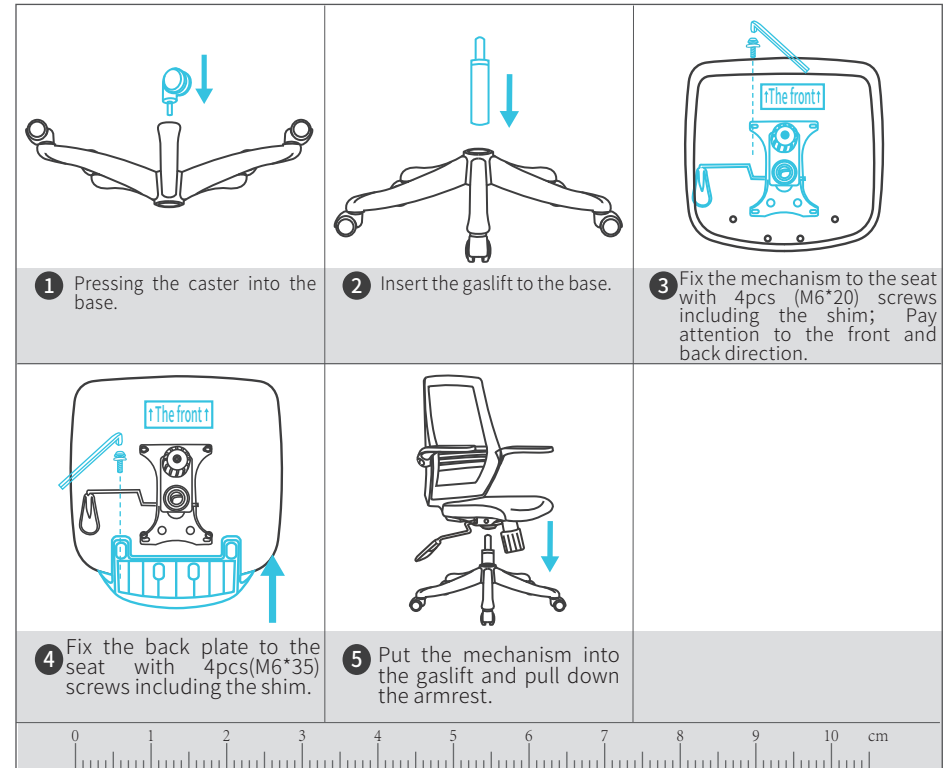

Notice: Before installation, pls classify the screw, measure the screw length for easy assemble

Benutzerhandbuch

Installation und Inbetriebnahme

- Bitte lesen Sie alle Installationsanweisungen (Abbildung) vor der Installation sorgfältig durch, um die Installationsschritte und -methoden zu beherrschen.
- Überprüfen Sie, ob die Teile vollständig und beschädigt sind.
- Wählen Sie beim Zusammenbau einen geräumigen und sauberen Standort. Das Papier wird flach auf den Boden gelegt, um zu verhindern, dass Teile während der Installation mit dem Boden kollidieren.
- Entfernen Sie nach der Installation mit einem weichen Flanell den Schmutz auf der Möbeloberfläche. Wischen Sie die Möbel NICHT mit einem Lappen mit Kies ab.



Bitte lesen Sie die folgenden Sicherheitshinweise sorgfältig durch.









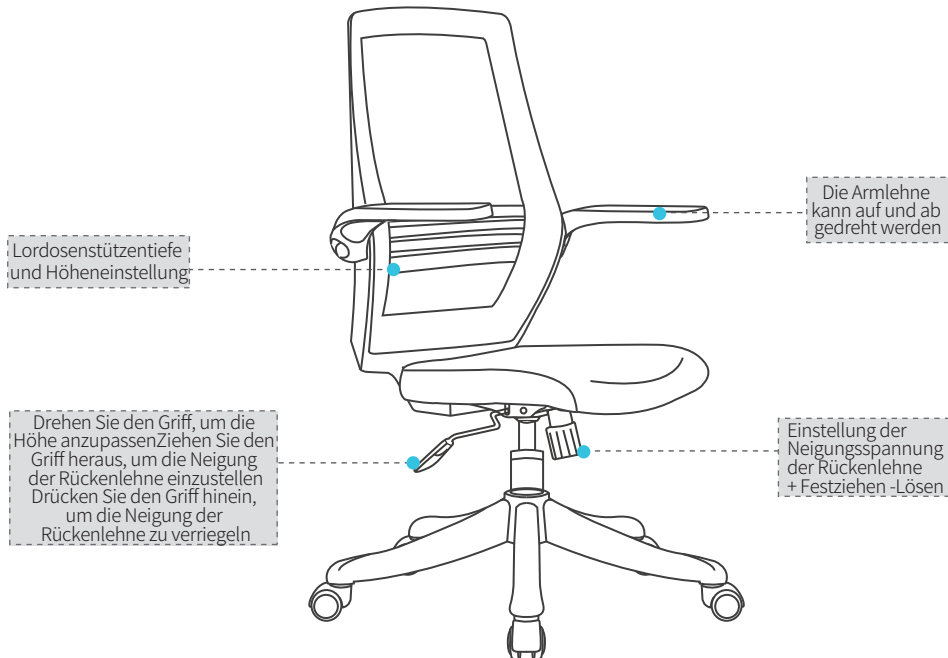

- Bitte benutzen Sie es auf einem flachen Boden und der Stuhl kann nur das Gewicht einer Person tragen;
- Um die Verwendung falscher Schrauben zu vermeiden, befestigen Sie bitte alle Schrauben, bevor Sie sie festziehen;
- Bitte lassen Sie das Kind nicht allein auf dem Stuhl sitzen, wenn es unter 5 Jahren ist;
- Bitte setzen Sie sich nicht auf die Armlehne, falls Gefahr besteht;
- Stellen Sie sich nicht auf den Stuhl und benutzen Sie ihn nicht als Leiter oder Fußtritt;
- Bitte legen Sie kein Übergewicht auf den Stuhl oder verwenden Sie ihn als Trolley;
- Verwenden Sie keine scharfen oder hakenförmigen Gegenstände, um den Stuhl zu zerkratzen. Gehen Sie nicht in die Nähe des Feuers;
- Führen Sie die Finger beim Sitzen nicht in den Mechanismus ein, um Ihre Finger nicht zu verletzen.

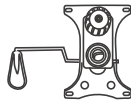
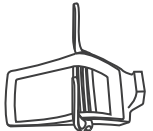

Funktionen (Die Größe basiert auf regelmäßigen Tests)

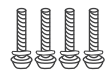

Liste der Einzelteile (Die Größe basiert auf regelmäßigen Tests)

			
Castor: 5Stk	Basis: 1pc	Mechanismus: 1pc	Rückenlehne: 1pc
			Hinweis: Klassifizieren Sie die Schraube vor dem Einbau anhand der Schraubenlänge, um die Montage zu erleichtern.
Sitzkissen: 1pc	Gaslift: 1pc	Sechskantschlüssel: 1pc	
			
Rückenplattenschraube (M6 * 35): 4+1St		Mechanismusschraube (M6 * 20): 4+1St	



Installationsanleitung (Die Größe entspricht den regulären Maßen)

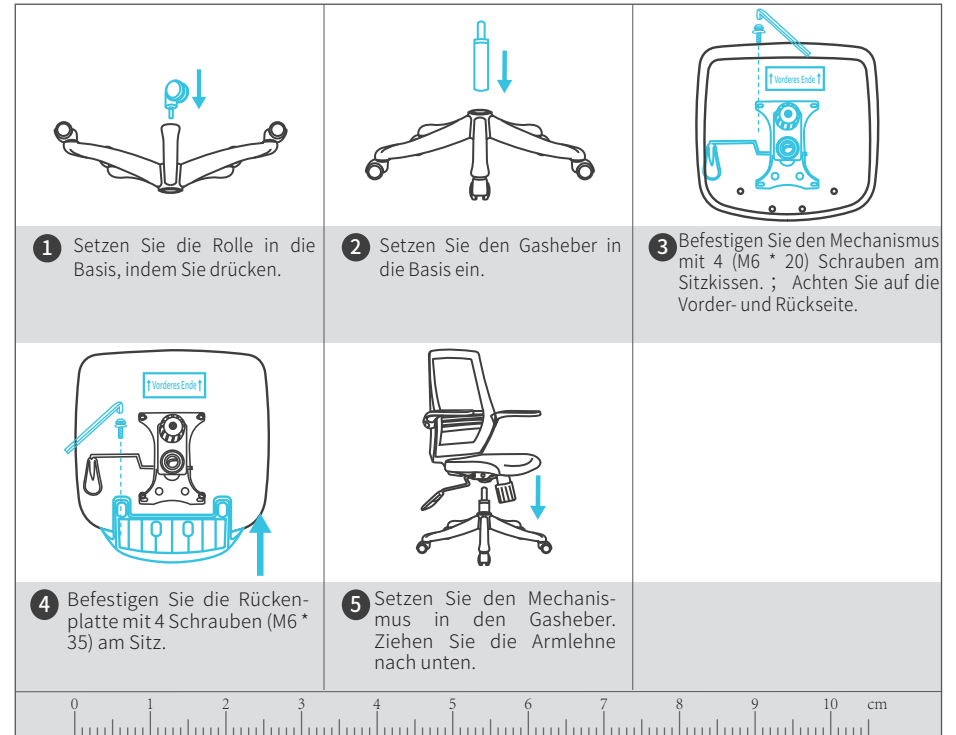

Hinweis: Klassifizieren Sie die Schraube vor dem Einbau anhand der Schraubenlänge, um die Montage zu erleichtern.

Manuel utilisateur

Installation et mise en service

1. Veuillez lire attentivement toutes les instructions d'installation (figure) avant l'installation pour maîtriser les étapes et les méthodes d'installation.
2. Vérifiez si les pièces sont complètes et endommagées.
3. Choisissez un site spacieux et propre lors de l'assemblage. Le papier est posé à plat sur le sol pour empêcher les pièces d'entrer en collision avec le sol pendant l'installation.
4. Utilisez une flanelle douce pour enlever la saleté sur la surface du meuble après l'installation. NE PAS essayer les meubles avec un chiffon de gravier.



Veillez lire attentivement les consignes de sécurité ci-dessous.



1. Veuillez l'utiliser sur un sol plat et la chaise ne peut supporter que le poids d'une personne;
2. Pour éviter d'utiliser les mauvaises vis, veuillez fixer toutes les vis avant de les serrer;
3. Veuillez ne pas laisser l'enfant seul sur la chaise s'il a moins de 5 ans;
4. Veuillez ne pas vous asseoir sur l'accoudoir, au cas où cela présenterait un danger;
5. Ne vous tenez pas sur la chaise et ne l'utilisez pas comme échelle ou comme marchepied;
6. Veuillez ne pas mettre de poids excessif sur la chaise ou être utilisé comme chariot;
7. N'utilisez pas d'objets tranchants ou crochus pour gratter le fauteuil et ne l'approchez pas près du feu;
8. Pour éviter tout dommage aux doigts, ne les insérez pas dans le mécanisme en position assise.



Fonctions (La taille sera conforme à la pratique habituelle)

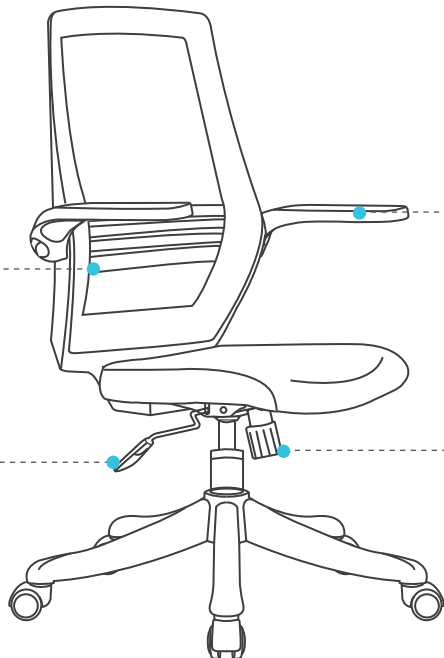









Réglage de la profondeur et de la hauteur du support lombaire

L'accoudoir peut être tourné de haut en bas

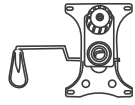
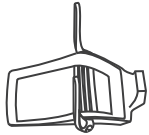
Tournez la poignée pour régler la hauteur. Tirez la poignée pour régler l'inclinaison du dossier. Poussez la poignée pour verrouiller l'inclinaison du dossier.



Réglage de la tension d'inclinaison du dossier + Serrer-Desserrer

Liste de pièces (la taille sera conforme aux mesures habituelles; une de plus à titre de sauvegarde)

			
Roulette: 5pcs	Base: 1pc	Mécanisme: 1pc	Dossier: 1pc
			Remarque: Avant l'installation, veuillez distinguer les vis par leur longueur pour faciliter l'assemblage.
Siège: 1pc	Élévation du gaz: 1pc	Clé hexagonale: 1pc	
			
Vis de la plaque arrière (M6 * 35): 4+1pcs		Vis de mécanisme (M6 * 20): 4 + 1 pièce	

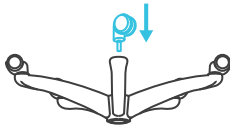
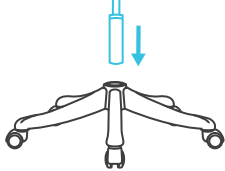
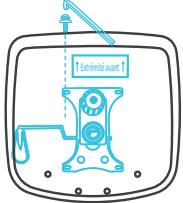
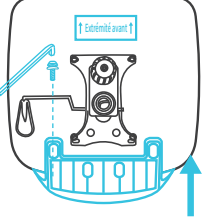

Assembler Introduction (la taille sera selon des mesures régulières)

		
1 Poussez les roulettes dans la base.	2 Insérez l'élevateur à gaz à la base.	3 Fixez le mécanisme au coussin du siège avec 4 vis (M6 * 20) ; Faites attention à l'avant et à l'arrière.
		
4 Fixez la plaque arrière au siège avec 4 vis (M6 * 35).	5 Placez le mécanisme dans l'ascenseur à gaz. Abaissez l'accoudoir	
0 1 2 3 4 5 6 7 8 9 10 cm		

Remarque: Avant l'installation, veuillez distinguer les vis par leur longueur pour faciliter l'assemblage.

Manual de usuario

Instalación y puesta en marcha

1. Lea atentamente todas las instrucciones de instalación (figura) antes de la instalación para dominar los pasos y métodos de instalación.
2. Compruebe si las piezas están completas y dañadas.
3. Elija un sitio espacioso y limpio cuando realice el montaje. El papel se deposita en el suelo para evitar que las piezas choquen con el suelo durante la instalación.
4. Use una franela suave para eliminar la suciedad en la superficie del mueble después de la instalación. NO limpie los muebles con un trapo con grava.



Por favor lea las instrucciones de seguridad a continuación cuidadosamente









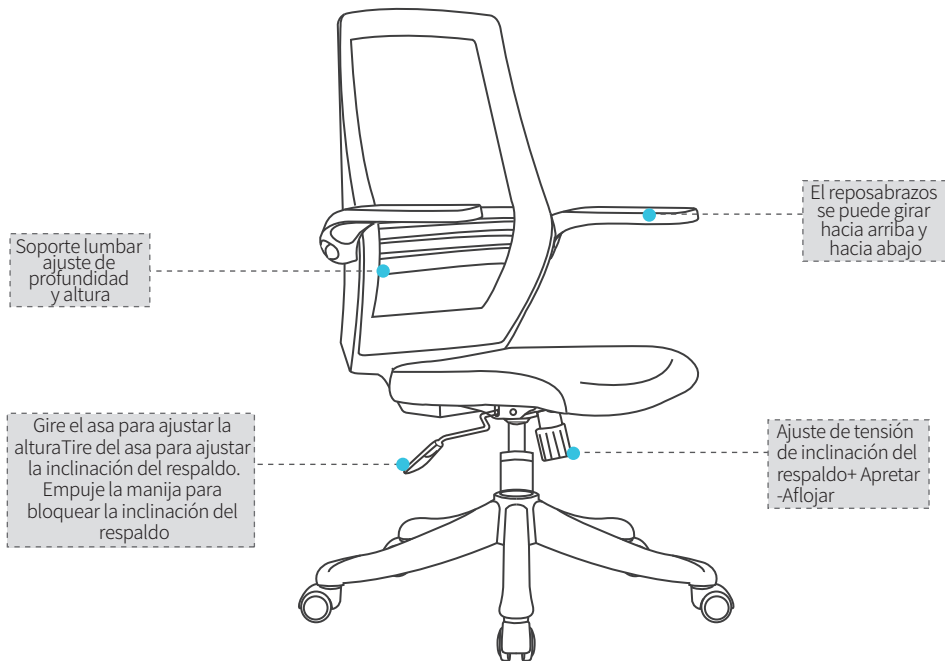

1. Úselo en un piso plano y una silla solo puede soportar el peso de una persona;
2. Para evitar el uso de tornillos incorrectos, fíjelos antes de apretarlos;
3. No deje que el niño se siente solo en la silla si tiene menos de 5 años;
4. Por favor, no se siente en el reposabrazos, en caso de causar algún peligro;
5. No se pare en la silla ni la use como escalera o pasos;
6. Please don't put overweight on the chair, or used as trolley;
7. Por favor, no coloque sobrepeso en la silla, o que se use como carro;
8. Para evitar cualquier daño a sus dedos, no los inserte en el mecanismo mientras está sentado.

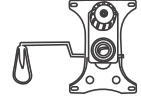

Funciones (El tamaño será de acuerdo a la práctica regular)

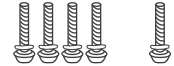

Lista de piezas (el tamaño será de acuerdo con las mediciones regulares; una más como respaldo)

			
Rueda: 5 piezas	Base: 1pc	Mecanismo: 1pc	Respaldo: 1pc
			Nota: prima dell'installazione, distinguere le viti in base alla lunghezza per facilitare il montaggio.
Asiento: 1pc	Elevación de gas: 1pc	Llave hexagonal: 1pc	
			
Tornillo de la placa posterior (M6 * 35): 4+1 pcs		Tornillo del mecanismo (M6 * 20): 4+1 pcs	



Ensamblar Introducción (El tamaño será de acuerdo a las medidas regulares)

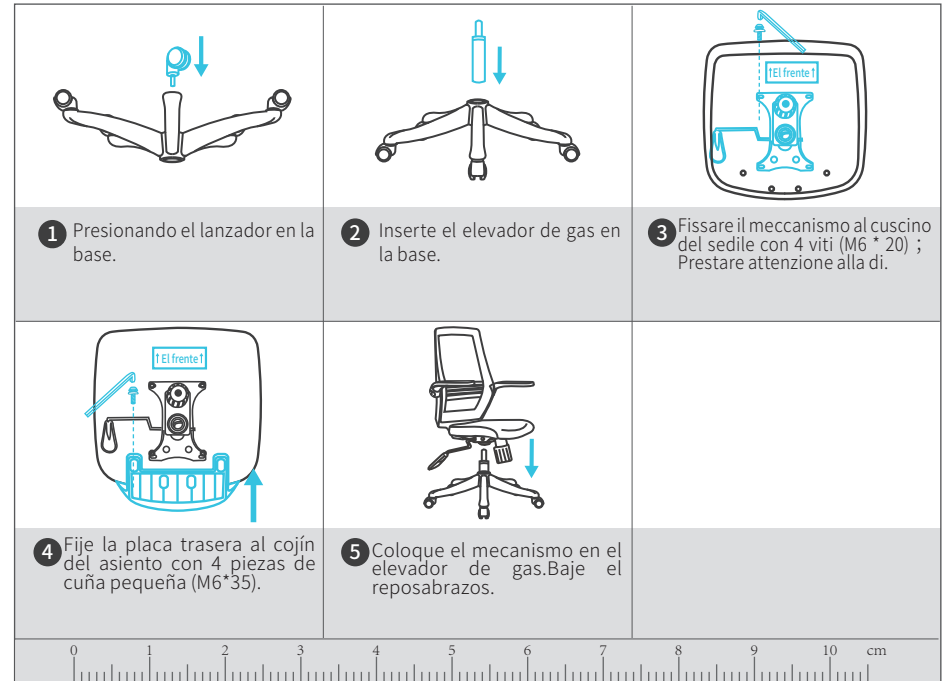

Nota: Antes de la instalación, distinga los tornillos según longitud para facilitar el montaje.