

KINCAID

—SOLID WOOD SINCE 1946—









www.kincaidfurniture.com

phone :828-728-3261.

ASSEMBLY INSTRUCTION

161-915 Washburn End Table

HARDWARE LIST

A		Nut	Ø5/16"	8 PCS
B		Lock Washer	Ø5/16"	8 PCS
C		Flat Washer	Ø5/16"*19D	8 PCS
D		Spanner Wrench	12MM	1 PC
E		Bolt	Ø1/4"*5/8"	4 PCS
F		Lock Washer	Ø1/4"	4 PCS
G		Flat Washer	Ø1/4"*16D	4 PCS
H		Allen Key	100*50*4mm	1 PC

PART LIST

1	Table Top	1 PC
2	Leg	4 PCS
3	Bottom Shelf	1 PC

IMPORTANT NOTES

- . Place all wooden parts on clean and smooth surface such as rug or carpet to prevent the parts from being scratched.
- . Check to be sure that you have all parts and hardware.
- . Remove all wrapping materials, including staples and packing straps before you start to assemble.
- . Do not tighten all screws and bolts until completely assembled.
- . Keep all hardware out of the reach of children

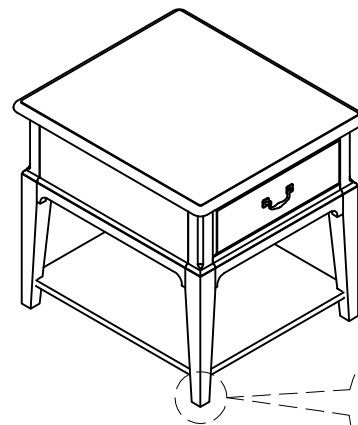

Adjustable Leveler

Adjust leveler if needed to level case on uneven floor.

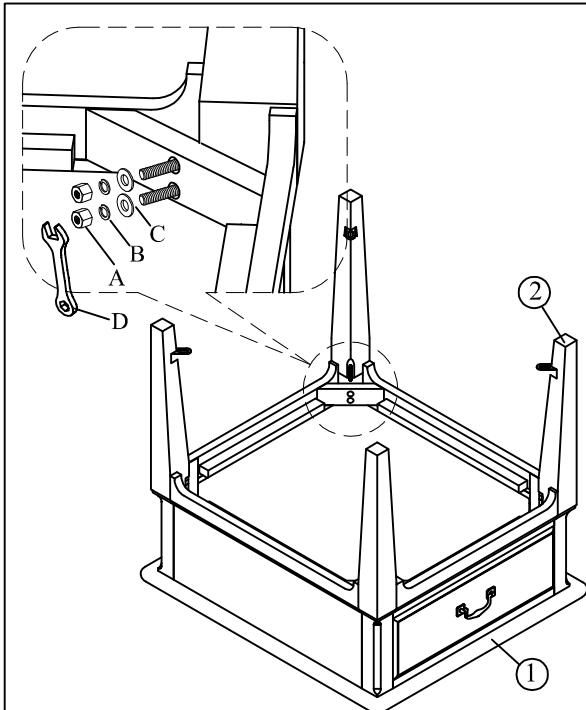

STEP 1. Put the table top (1) upside down on clean soft surface attach the leg (2) to the table top (1) as shown in the picture using nut (A), lock washer (B), flat washer (C). Important: Do not over-tighten .

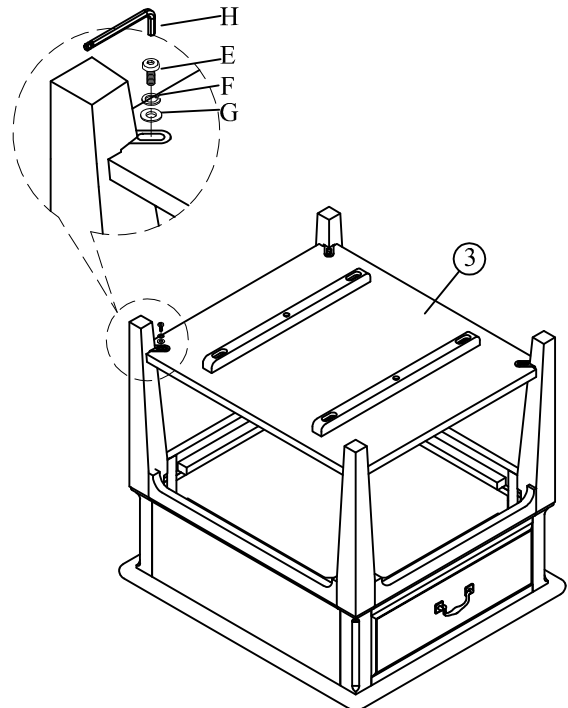

STEP 2. Attach the bottom shelf (3) to the leg (2) as picture shown by using bolt (E), lock washer(F), flat washer (G), and tighten with allen key (H). not too tight. Then tighten nut (A) by spanner wrench (D) (in step 1) and tighten bolts (E) using the allen key (H)

MADE IN VIETNAM