

Attention: Don't tighten the allen bolt before all allen bolt in place

USER'S MANUAL
DiningTable
20TNTVDS01BR120

BEFORE YOU GET STARTED, A FEW POINTERS



Having a friend to help makes assembly extra-easy



Mind the important safety information

★ PLEASE MAKE SURE ALL THE PARTS ARE INCLUDED.

1

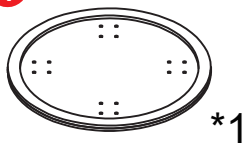

*1

Tabletop

2

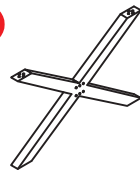

*1

Table legs

3

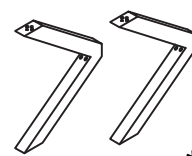

*2

Separate table legs

4

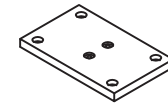

*4

Square beetle

A



Ø5/16"x70mm
(8pcs)

B



Ø5/16"x35mm
(8pcs)

C



Ø1/4"*25mm
(16pcs)

D



Ø5/16"
(16pcs)

E



Ø5/16"
(16pcs)

F



Ø1/4"
(16pcs)

G



Ø1/4"
(16pcs)

H

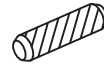

Wood dowel
(12pcs)

J



M4 Allen Key
(1pc)

Missing parts ?  hyltech@outlook.com

ASSEMBLY INSTRUCTIONS - ATTENTION

STEP 1

Use wood dowels (H) connect table leg (2) and one separate table leg (3). Then tighten them with screws (A), spring washers (D) and flat washers (E) by using Allen wrench (J).

Friendly Notice:

If the rotation positions can not be aligned well, gently shake the table leg(2) when locking the bolts, this can help avoid stuck operations and poor installation. Do not tighten the bolts completely, just 50% is ok.

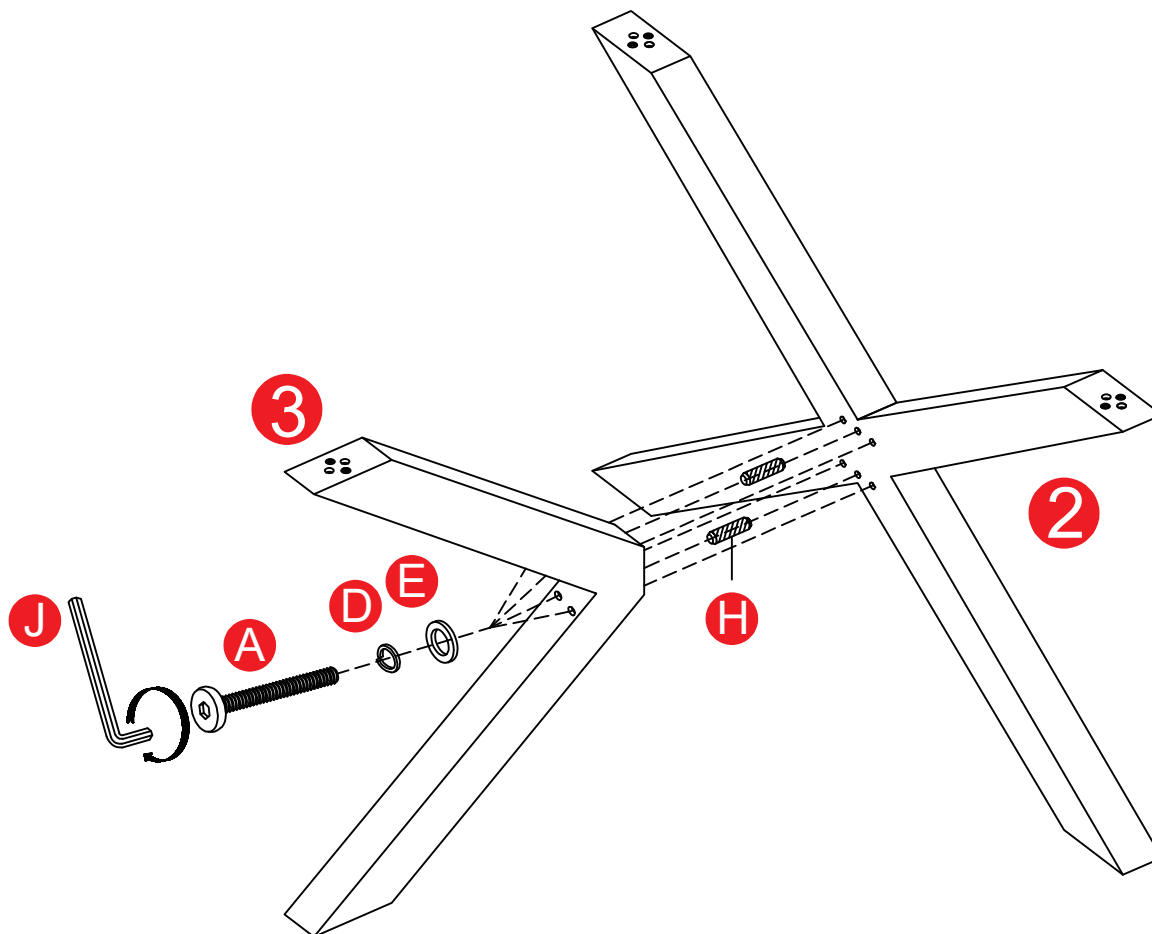

ASSEMBLY INSTRUCTIONS - ATTENTION

STEP 2

Repeat step 1 for another side.

Notice: Don't over tighten the bolts, just tighten them to 50% and it's ok.

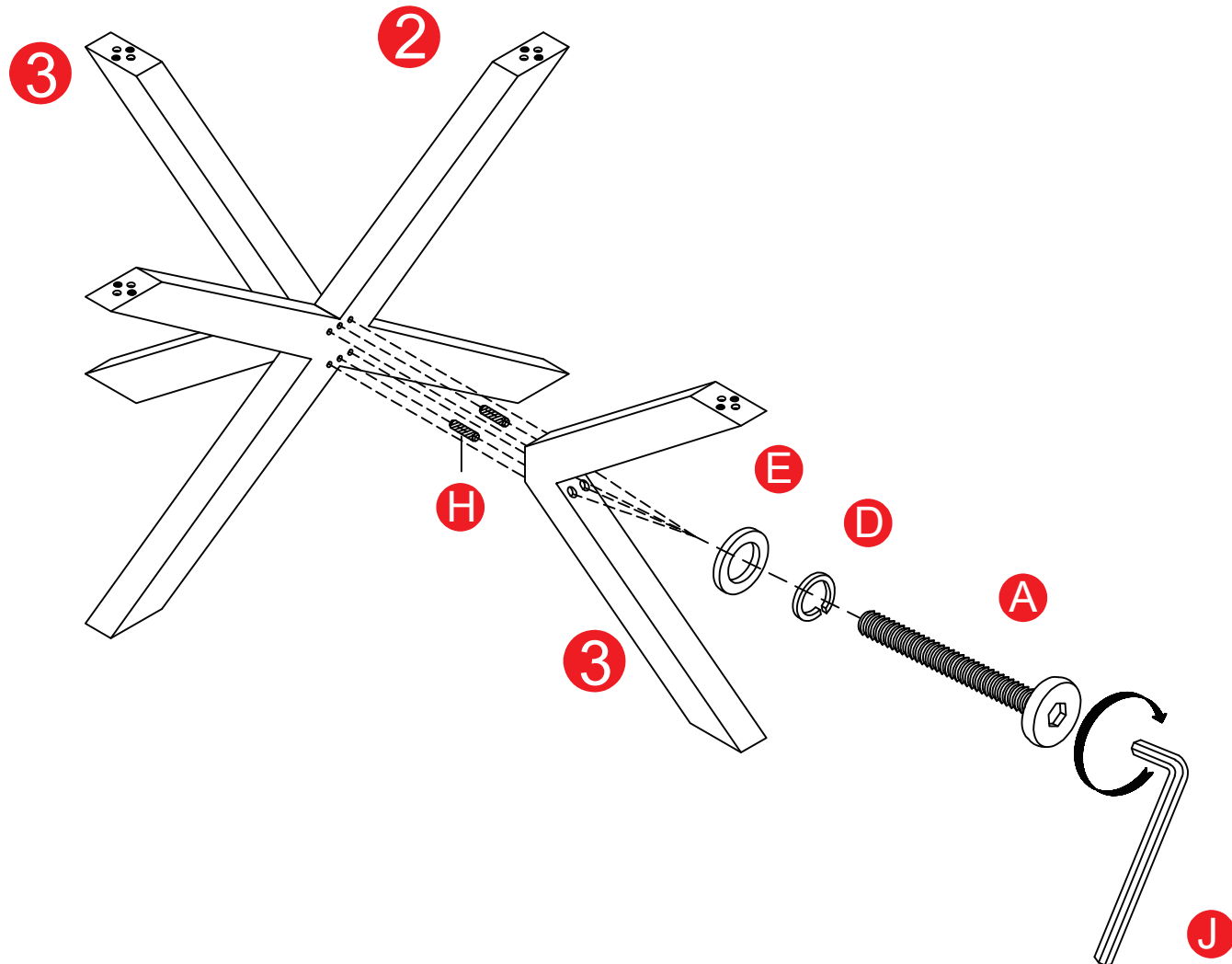

ASSEMBLY INSTRUCTIONS - ATTENTION

STEP 3

Use wood dowels (H) fix square beetles (4) on the top of table legs (2) and separate table legs (3), then tighten them with screws (B), spring washers (D) and flat washers (E) by using Allen wrench (J)

Kindly Notice: Don't over tighten the bolts, just tighten them to 50% and it's ok.

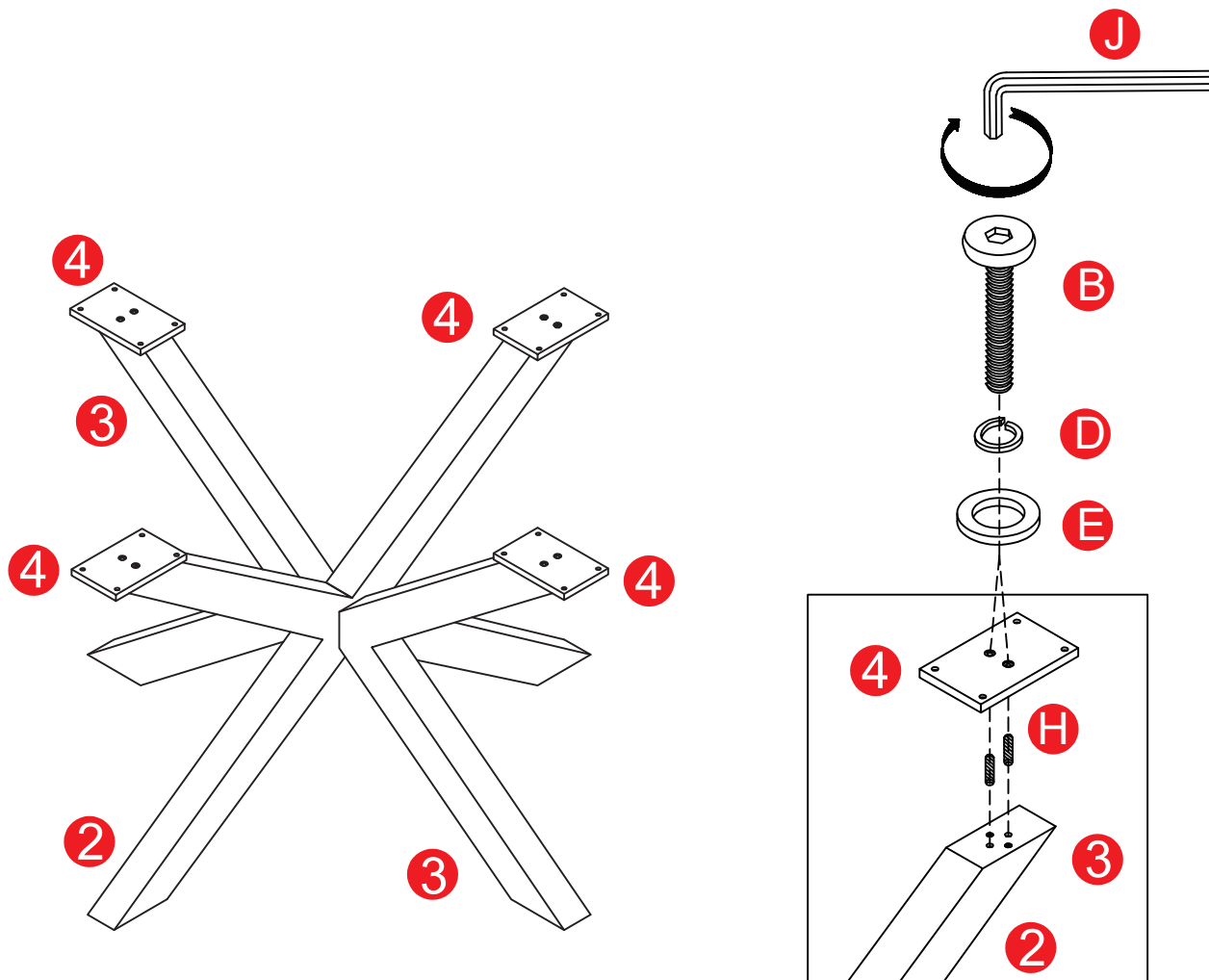

ASSEMBLY INSTRUCTIONS - ATTENTION

STEP 4

Use screws (C), spring washers (F) and flat washers (G) with Allen wrench (J) to connect square beetles (4) to the table top (1). After adjust the balance of the entire table then tighten all bolts to 100%.

Stand the table up.

Your table is ready for use. This table can only be used on a flat, level surface.

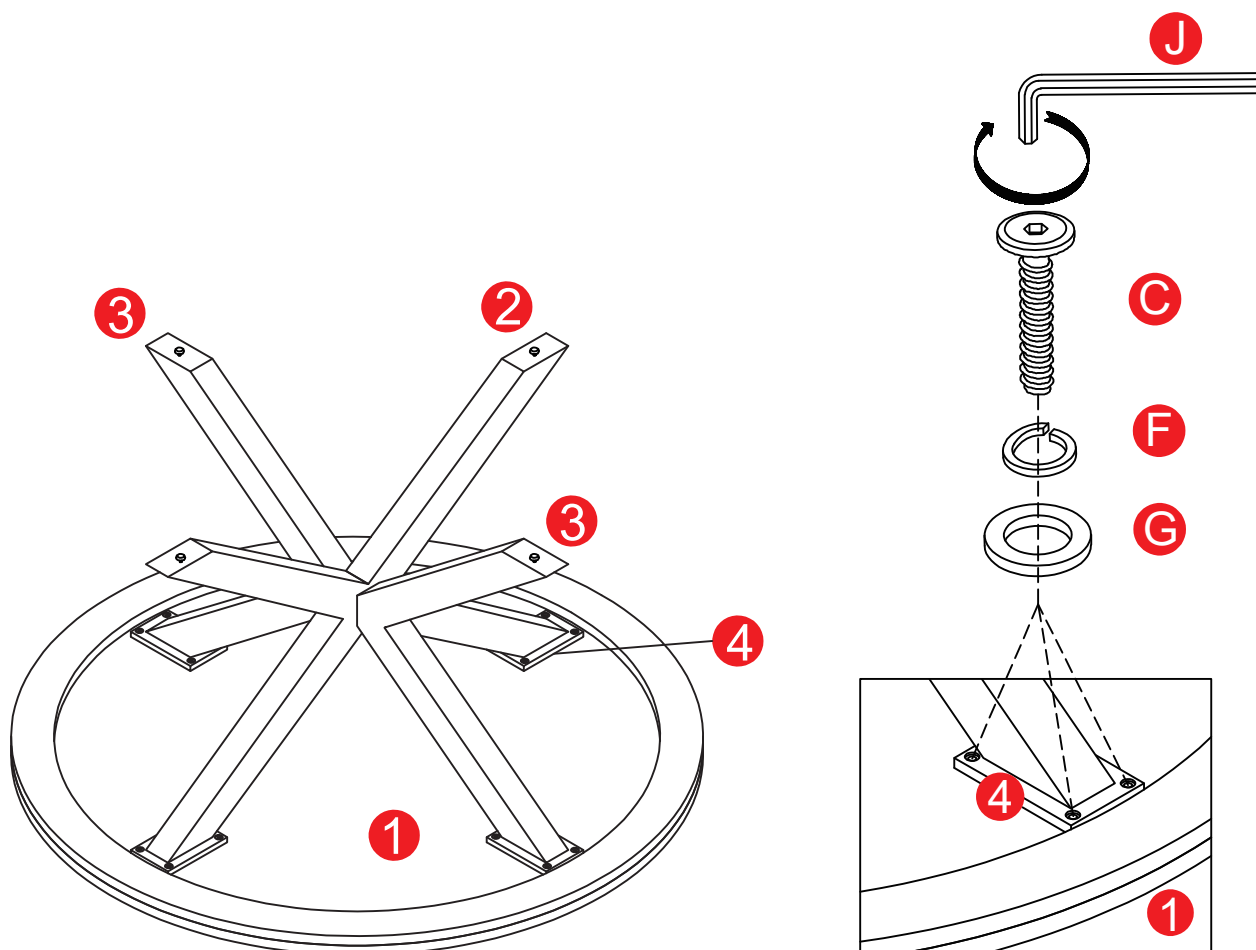

ASSEMBLY INSTRUCTIONS - ATTENTION

Please read the following instructions to help you assemble the dining table faster.

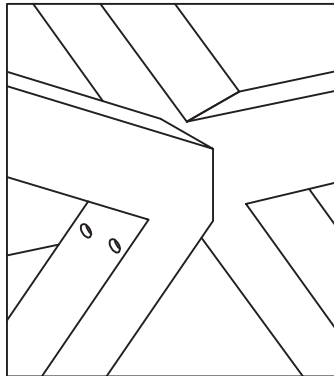

50%
↻

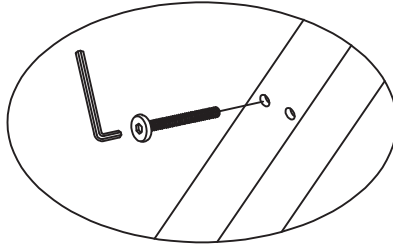

1. Partly screw in bolts, but do not fully tighten.

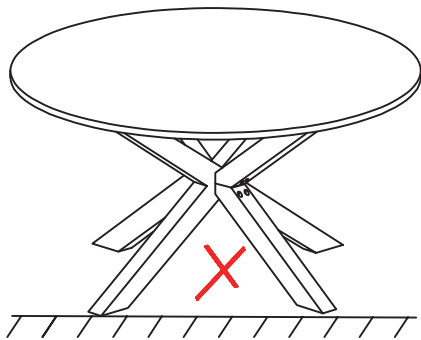

Apply pressure on the Table. (About 80lbs)

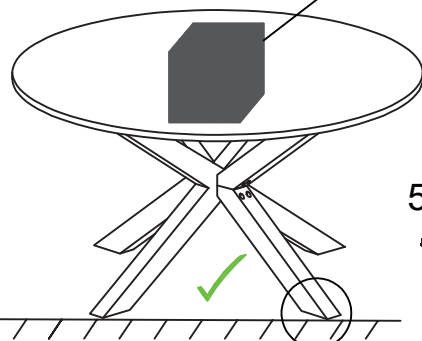
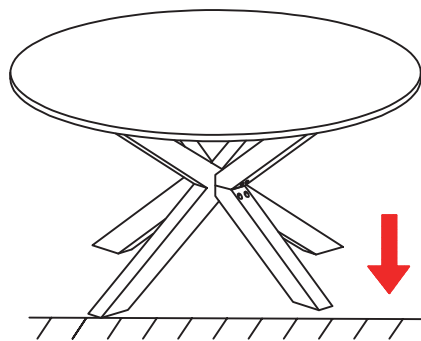

50%
↻

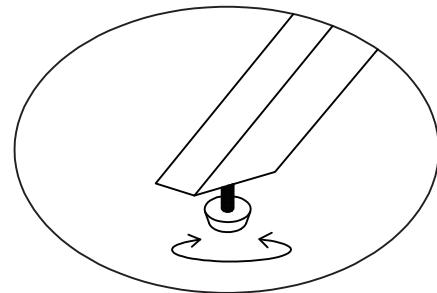

2. If your feet are not flat, you can also adjust the Adjustment Feet on the bottom of your feet to improve your balance.



WARNING:



Read the instructions carefully.

step1

↓
step2

Please follow the assembly steps.

Weight Capacity : 250LBS

To ensure proper assembly, follow all steps and use all parts, do not use power tools. Failure to follow this warning can result in serious injury to yourself or others.

Please inspect all items before assembly, if for any reason you need to return this item, please kindly return in it's original packaging.

To avoid misalignments, leave the screws loose and do not tighten them until all are in their respective places.

Do not tighten all bolts and screws completely until the entire unit has been assembled and set up.

Do not overtighten or force the screws as they could break, strip, or damage the threads of the holes.

Using the wrong size of screws on a part could result in damage to the screw or the part.

Lubricate all moving parts and tighten all bolts/screws every 6 month or whenever needed.

Do not use if this product becomes damaged, and / or components are broken or missing.