

NOTICE

- * Please make sure that you have all parts indicated and they are in good condition before you begin assembly of this item. Refer to part list and hardware list below for guidance.
- * This item should be assembled on a soft surface to prevent scratching the finish during assembly.
- * This item may require periodic tightening.
- * If you are having difficulty, our friendly Customer Care team is always here to help.

PREPARATION

- * Before beginning assembly of product, make sure all parts are present. Compare parts with part contents list and hardware contents list.
- * If any part is missing or damaged, do not attempt to assemble the product.
- * Estimated Assembly Time: **120 minutes.**
- * Tools Required for Assembly (included): **Allen Key**

CARE AND MAINTENANCE

Store outdoor furniture indoors or cover well when not in use. Dust regularly with small brush or vacuum. Spills should be taken care of immediately before they harden or stain with a slightly damp sponge.

Part List and Hardware List

PIECE	DESCRIPTION	PICTURE	QUANTITY
A	Top Table Frame		1X
B	Right Bench Frame		1X
C	Left Bench Frame		1X
D	Corner Bench Frame		1X
E	Back Bench Frame		3X
F	Back Corner Frame		1X
G	Leg Table Frame		4X
H	Leg Side Bench Frame		4X
I	Leg Bench Frame		8X
CSH1	Seat Cushion		3X
CSH2	Back Cushion		6X
CSH3	Small Back Cushion		1X
HW1	Allen Bolt: M6 x 0.5 x 20 mm		64X
HW2	Allen Bolt: M6 x 0.5 x 35 mm		22X
HW3	Flat Washer: M6 x 1 mm		86X
HW4	Allen Key		3X

Product Dimensions:

Table: 35.43"W x 19.69"D x 15.16"H

Right Bench: 54.33"W x 27.56"D x 27.56"H

Left Bench: 54.33"W x 27.56"D x 27.56"H

Corner Bench: 47.05"W x 27.56"D x 27.56"H

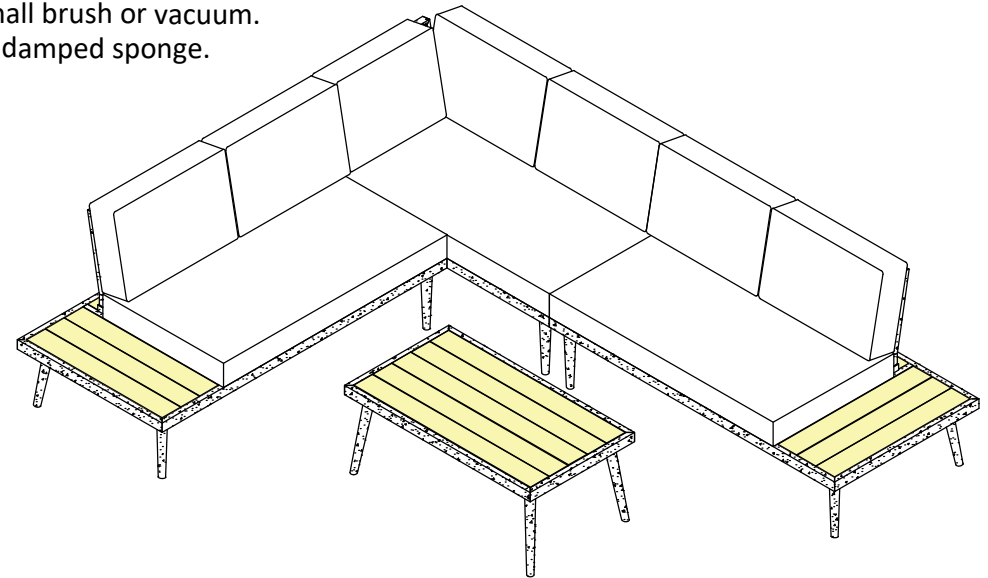

Weight Capacity : 176 lbs (Table)
704 lbs (Bench)

Warning : Do not stand on Table/Bench
Warning : Do not over torque bolts

NOTICE

- * Please make sure that you have all parts indicated and they are in good condition before you begin assembly of this item. Refer to part list and hardware list below for guidance.
- * This item should be assembled on a soft surface to prevent scratching the finish during assembly.
- * This item may require periodic tightening.
- * If you are having difficulty, our friendly Customer Care team is always here to help.

PREPARATION

- * Before beginning assembly of product, make sure all parts are present. Compare parts with part contents list and hardware contents list.
- * If any part is missing or damaged, do not attempt to assemble the product.
- * Estimated Assembly Time: **60 minutes.**
- * Tools Required for Assembly (included): **Allen Key**

CARE AND MAINTENANCE











Store outdoor furniture indoors or cover well when not in use. Dust regularly with small brush or vacuum. Spills should be taken care of immediately before they harden or stain with a slightly damp sponge.

Product Dimensions:

Right Bench: 54.33"W x 27.56"D x 27.56"H

Left Bench: 54.33"W x 27.56"D x 27.56"H

Part List and Hardware List

PIECE	DESCRIPTION	PICTURE	QUANTITY
B	Right Bench Frame		1X
C	Left Bench Frame		1X
E	Back Bench Frame		2X
H	Leg Side Bench Frame		4X
I	Leg Bench Frame		4X
CSH1	Seat Cushion		2X
CSH2	Back Cushion		4X
HW1	Allen Bolt: M6 x 0.5 x 20 mm		32X
HW2	Allen Bolt: M6 x 0.5 x 35 mm		12X
HW3	Flat Washer: M6 x 1 mm		44X
HW4	Allen Key		1X

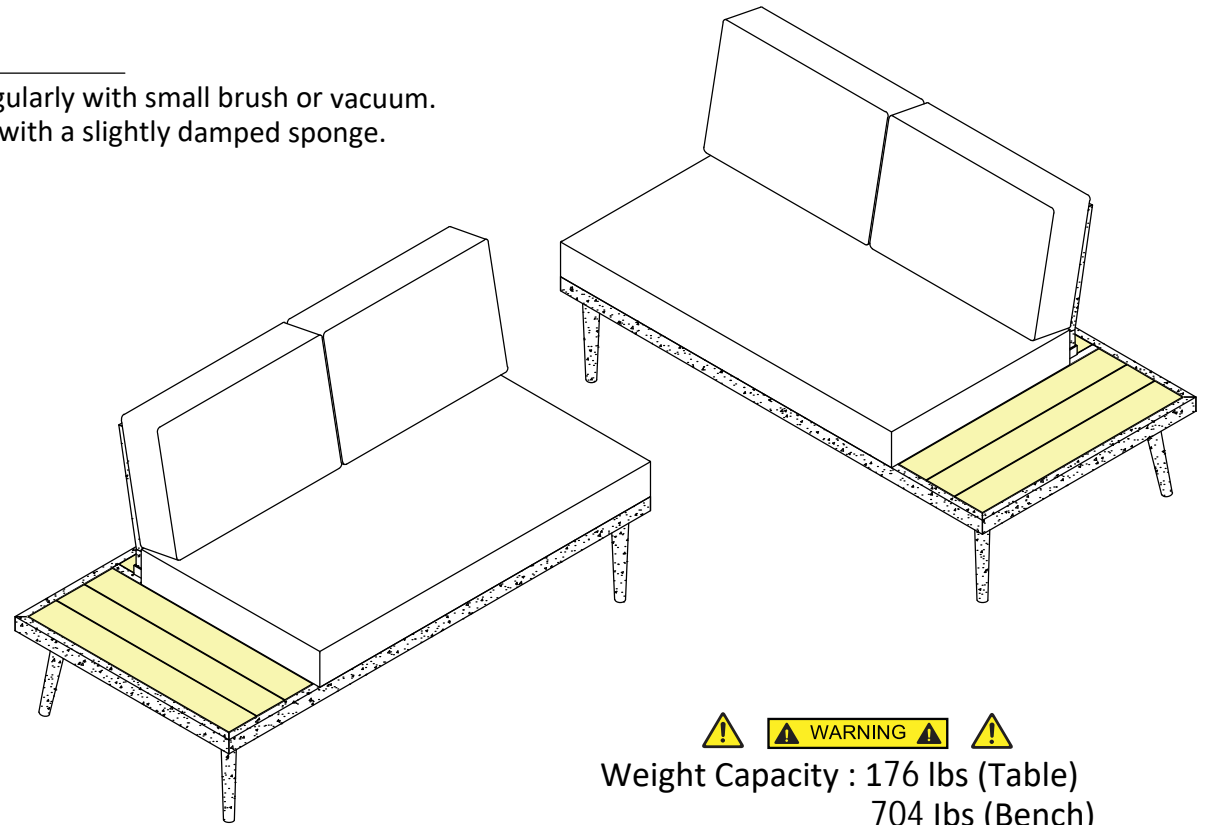

Weight Capacity : 176 lbs (Table)
704 lbs (Bench)

Warning : Do not stand on Table/Bench
Warning : Do not over torque bolts

PREPARATION

- * Before beginning assembly of product, make sure all parts are present. Compare parts with part contents list and hardware contents list.
- * If any part is missing or damaged, do not attempt to assemble the product.
- * Estimated Assembly Time: **40 minutes.**
- * Tools Required for Assembly (included): **Allen Key**
- * If you are having difficulty, our friendly Customer Care team is always here to help.

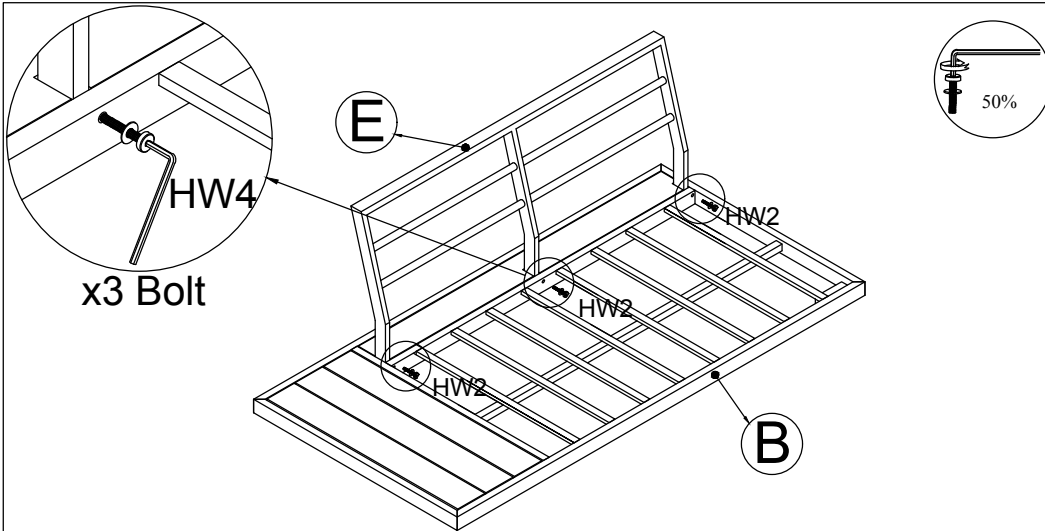

STEP 1: Connect Right Bench Frame (B) and Back Bench Frame (E), tighten Bolt (HW2), Flat washer (HW3) with Allen Key (HW4).

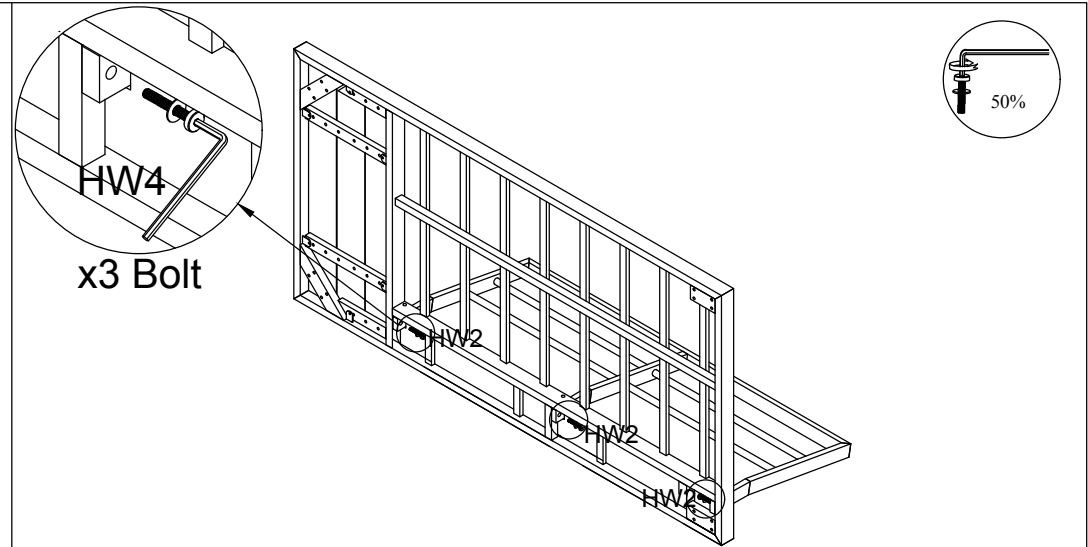

STEP 2: Connect the Part from STEP 1, tighten Bolt (HW2), Flat washer (HW3) with Allen Key (HW4).

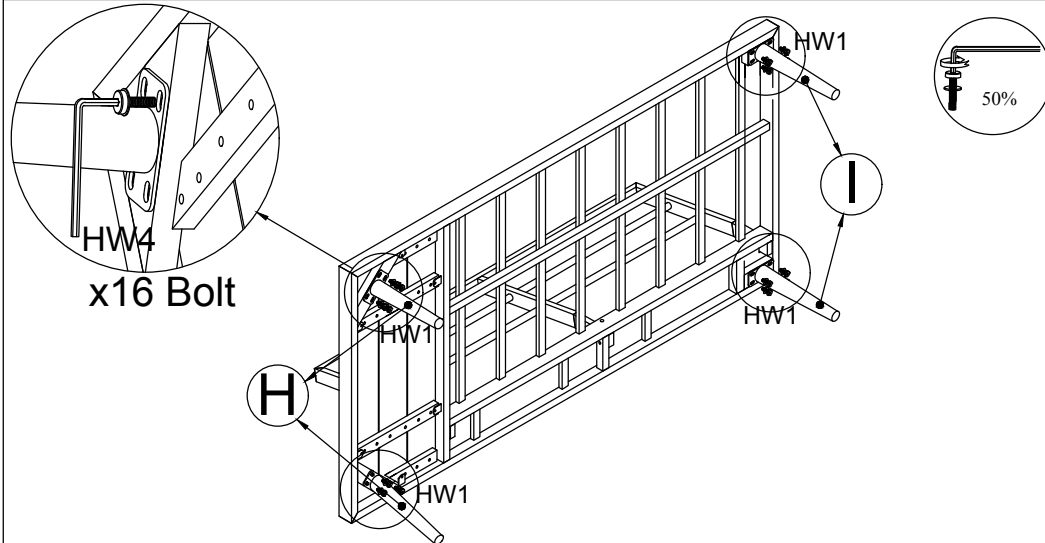

STEP 3: Connect The Part from STEP 2 and Leg Side Bench Frame (H), Leg Bench Frame (I), tighten Bolt (HW1), Flat Washer (HW3) with Allen Key (HW4).

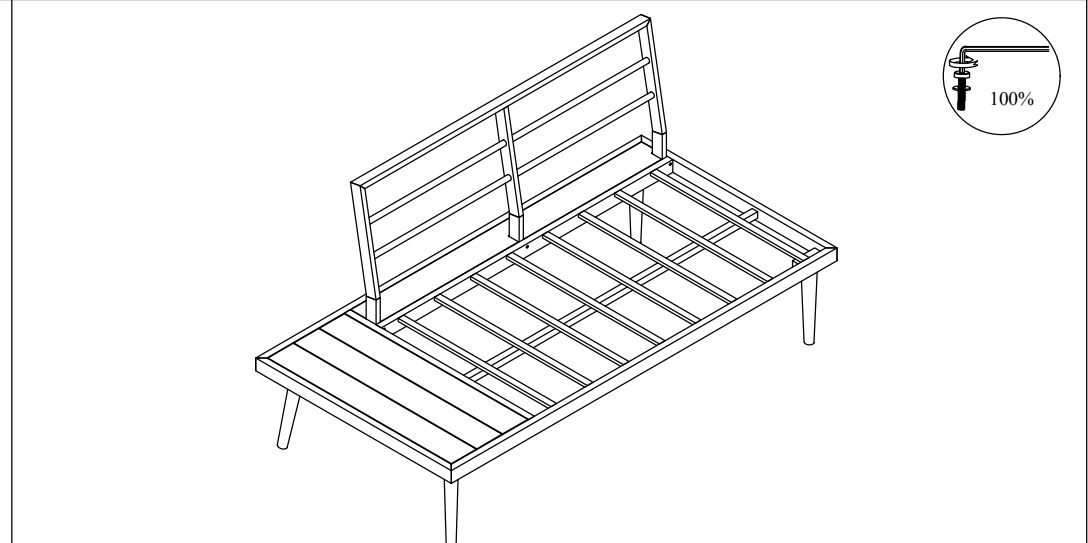

STEP 4: Put the Right Bench upright and make sure all legs are level, then firmly tighten Bolts with Allen Key (HW4)

PREPARATION

- * Before beginning assembly of product, make sure all parts are present. Compare parts with part contents list and hardware contents list.
- * If any part is missing or damaged, do not attempt to assemble the product.
- * Estimated Assembly Time: **60 minutes**.
- * Tools Required for Assembly (included): **Allen Key**
- * If you are having difficulty, our friendly Customer Care team is always here to help

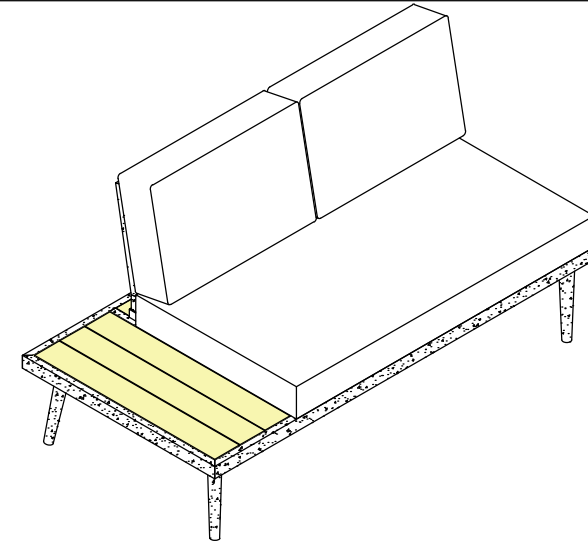
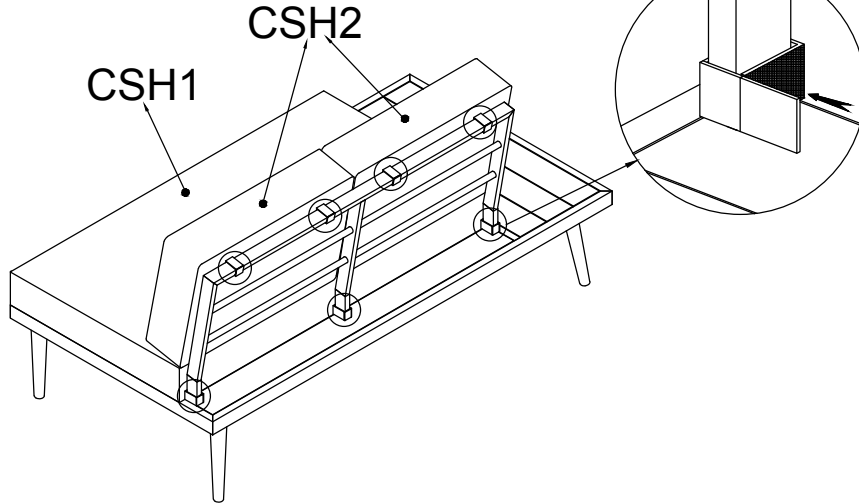

Step 5 : Put on Seat Bench Cushion (CSH1), Back Bench Cushion (CSH2), to Right Bench. Stick string to Back Bench Sofa to finish Right Bench.

Finish Right Bench

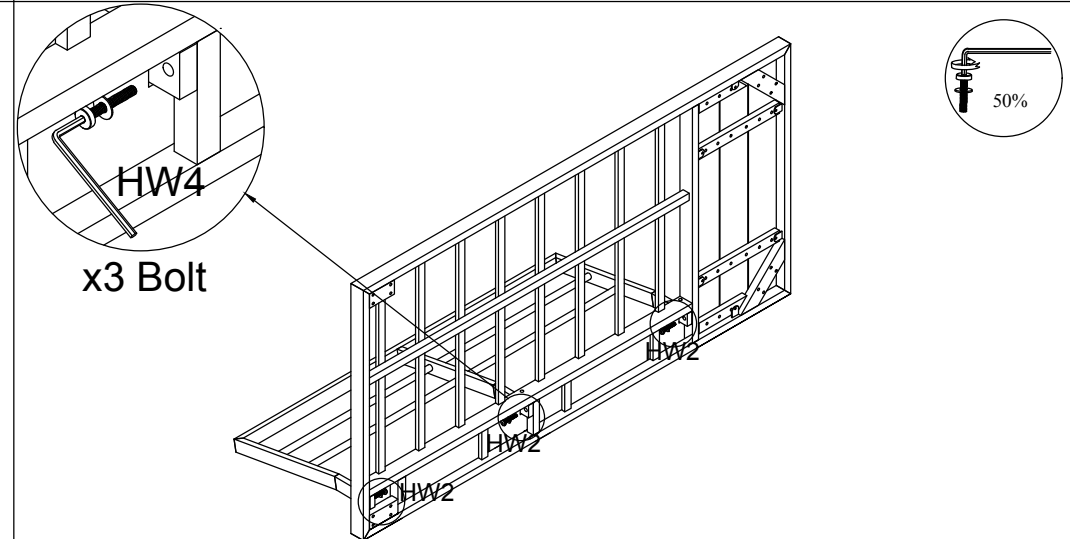
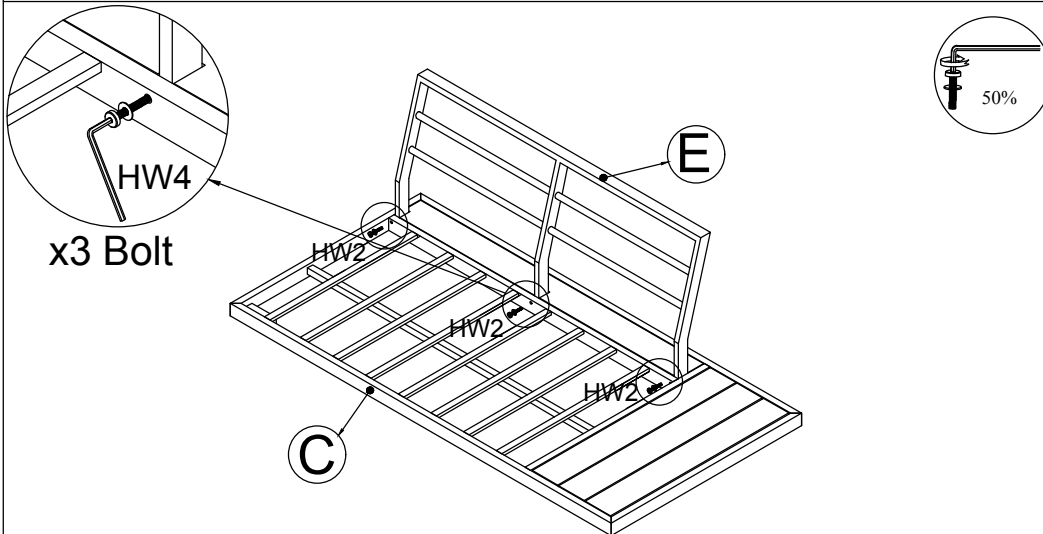

STEP 6: Connect Left Bench Frame (C) and Back Bench Frame (E), tighten Bolt (HW2), Flat Washer (HW3) with Allen Key (HW4).

STEP 7: Connect the Part from STEP 6, tighten Bolt (HW2), Flat Washer (HW3) with Allen Key (HW4).

PREPARATION

- * Before beginning assembly of product, make sure all parts are present. Compare parts with part contents list and hardware contents list.
- * If any part is missing or damaged, do not attempt to assemble the product.
- * Estimated Assembly Time: **40 minutes.**
- * Tools Required for Assembly (included): **Allen Key**
- * If you are having difficulty, our friendly Customer Care team is always here to help.

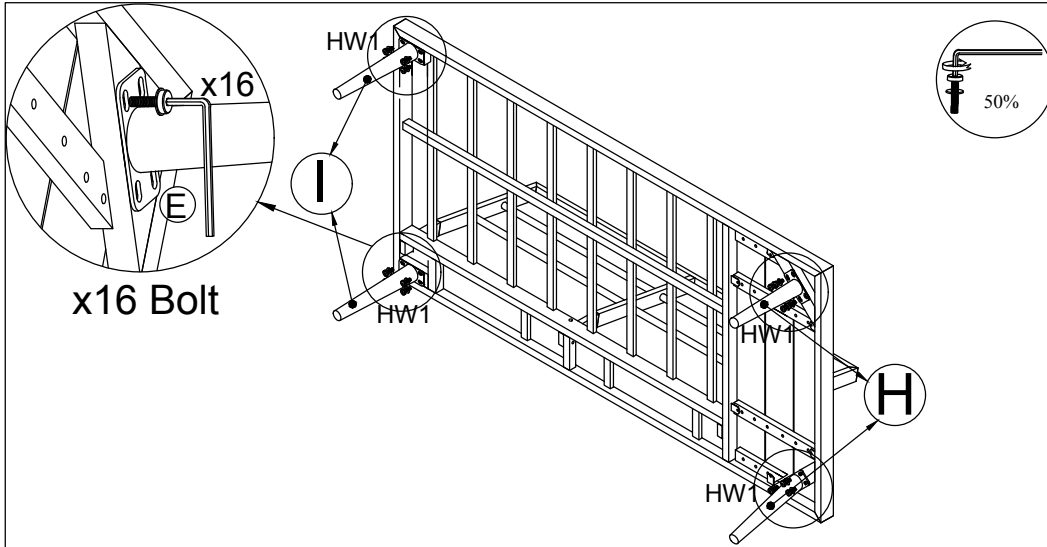

STEP 8: Connect The Part from STEP 7 and Leg Side Bench Frame (H), Leg Bench Frame (I), tighten Bolt (HW1), Flat Washer (HW3) with Allen Key (HW4).

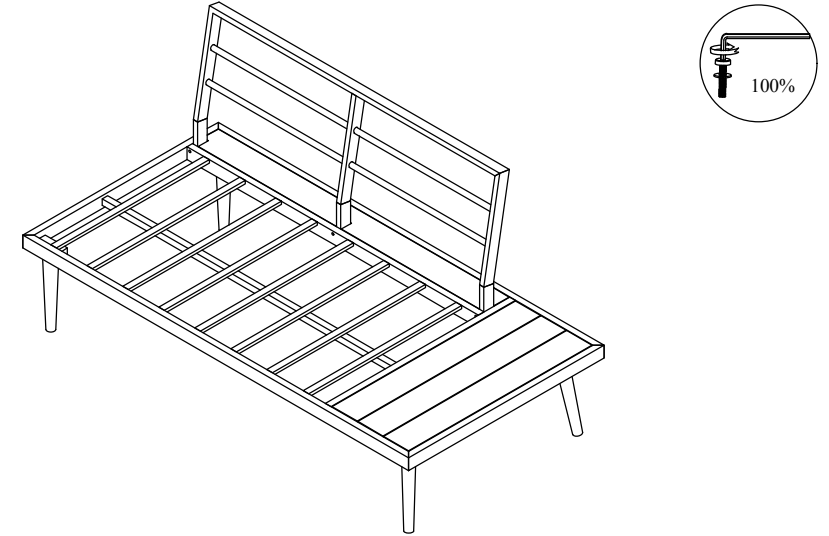

STEP 9: Put the Left Bench upright and make sure all legs are level, then firmly tighten Bolts with Allen Key (HW4)

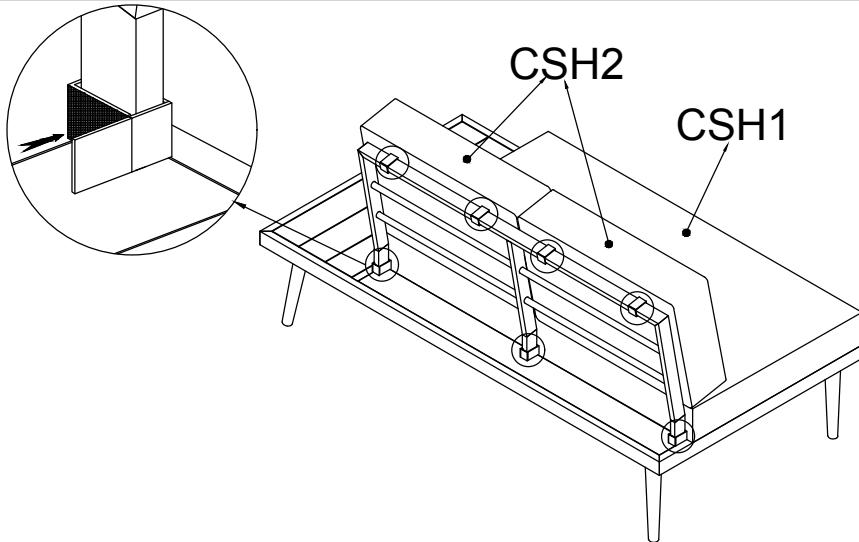

Step 10 : Put on Seat Bench Cushion (CSH1), Back Bench Cushion (CSH2), to Right Bench. Stick string to Back Bench Sofa to finish Left Bench.

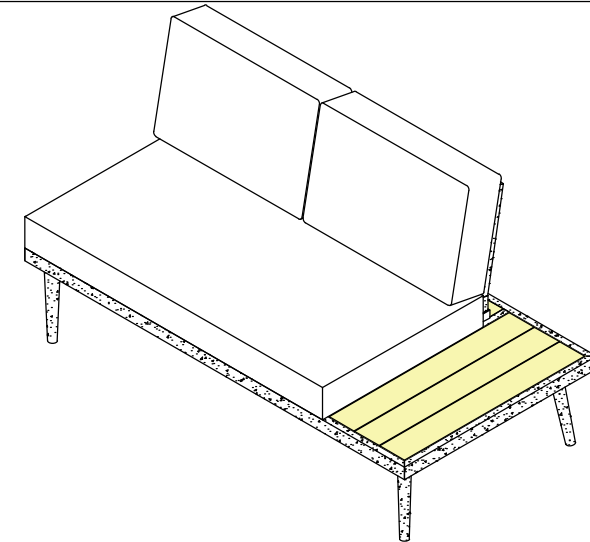

Finish Left Bench