

BOOKCASE

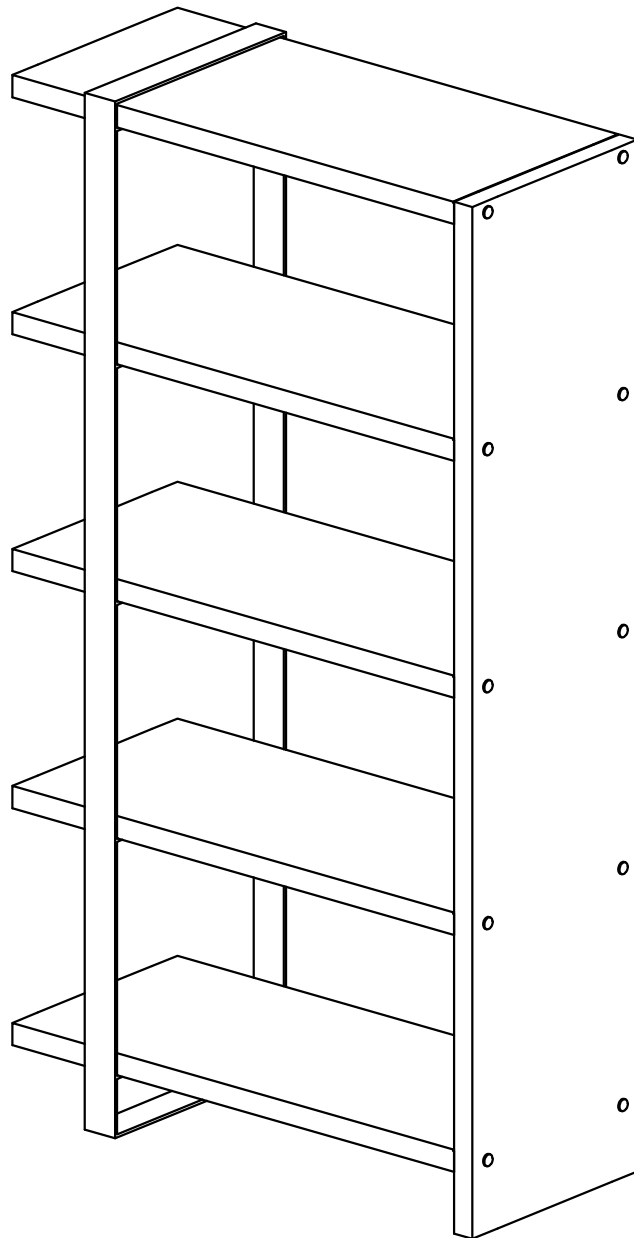



Questions, problems, assembly help, missing parts?

No need to return the product, we will gladly help and ship your replacement parts free of charge
Please call Customer Service

In order to assist you in a timely manner, please have the following information ready:

Model # _____ Part Number or Letter _____

Purchased at _____ Date of Purchase _____

If you wish to return the product, please contact the retailer where the product was purchased.

IMPORTANT : Please read this manual carefully before beginning assembly of this product. Keep this manual for future reference.

SAFETY INFORMATION

CAUTION: Injuries and damage can occur from furniture tip over if product is not properly anchored to the wall. Use the Furniture Anti-Tipping Restraint provided with the product. Consult our assembly instructions for help.

If the Furniture Anti-Tipping Restraint kit is not in the box, please contact our customer service department in order to obtain another kit before using the furniture.

Identify all the parts and hardware. Do not discard of the packaging until you have checked that you have all of the parts and hardware required. Hardware package may have spare parts.

WARNING: This item contains small parts which can be swallowed by children and pets. Keep children and pets away during assembly. To avoid danger of suffocation, always keep plastic bags away from children and pets. We recommend that you assemble this unit on a carpeted floor to avoid scratches. If using power tools, set the tool to low torque to avoid damage.

May require 2 people for ease of assembly.

IMPORTANT : Keep this manual for future reference.

CARE and MAINTENANCE

This furniture is designed for indoor use.

Damage to furniture can come from temperature changes in relative humidity (RH) in our homes. Humid air oxidizes metal which results in rusting, corrosion, tarnishing and roughness. Wood absorbs water as relative humidity rises and falls, and in doing so it swells and shrinks.

To protect against the humidity effect, the metal is powder coated. The powder coat layer protects the metal from oxidizing, corrosion, tarnishing and scratching and keeps it looking good for years to come. The wood is sealed and lacquered to protect against humidity.

To help protect your furniture, follow these steps:

- Use a humidifier, preferably one with an automatic control system that can sense the humidity level and adjust itself accordingly.
- Dust with soft dry cloth.
- Wipe up spills promptly. Clean with a dry cloth.
- Do not use abrasive cleaners, chemical solvents, strong detergents, cleaners with bleach, and furniture polish.
- Use soft felt base coasters, placemats to help prevent scratches.
- Keep furniture out of direct sunlight, which can cause cracking or roughness on the protective layer.
- If it can be avoided, do not put furniture near heating vents. Keep the furniture 3 to 4 inches away from the wall, giving heat and air space to circulate.

PRE-ASSEMBLY INFORMATION

PART DESCRIPTION

A

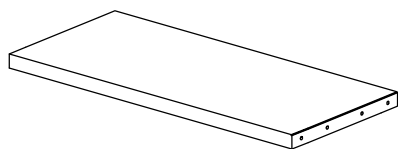

SHELF
QTY 5

B

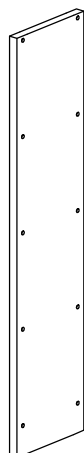

SIDE PANEL
QTY 1

C

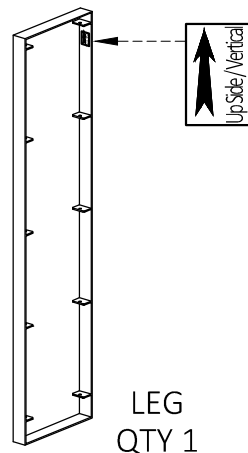

LEG
QTY 1

HARDWARE DESCRIPTION

1

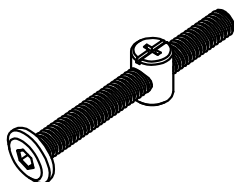

ALLEN KEY BOLT & CROSS NUT
M6 X 50mm
QTY 10 SETS

2

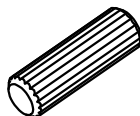

WOOD DOWEL
Ø8 X 25mm
QTY 10

3



ALLEN KEY BOLT
M6 X 20mm
QTY 20

4



LOCK WASHER
Ø10/Ø6x1.5mm
QTY 20

5



WASHER
Ø14/Ø6.5 x 1.5mm
QTY 20

6

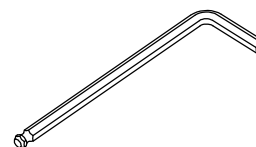

ALLEN KEY
QTY 1

7

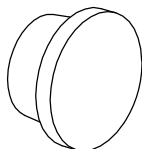

WOODEN BOLT CAP
QTY 10

8

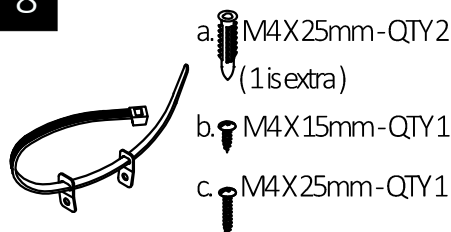

FURNITURE TIP OVER RESTRAINT
QTY 1 SET

- a. M4X25mm-QTY2
(1 is extra)
- b. M4X15mm-QTY1
- c. M4X25mm-QTY1

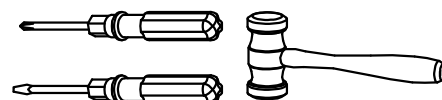

Required -
Flathead screwdriver
Phillips screwdriver
Rubber mallet
Not Included

NEED HELP? For help with assembly or if you are missing a part,
Please call customer service.

COMPONENTS-KEY DIAGRAM

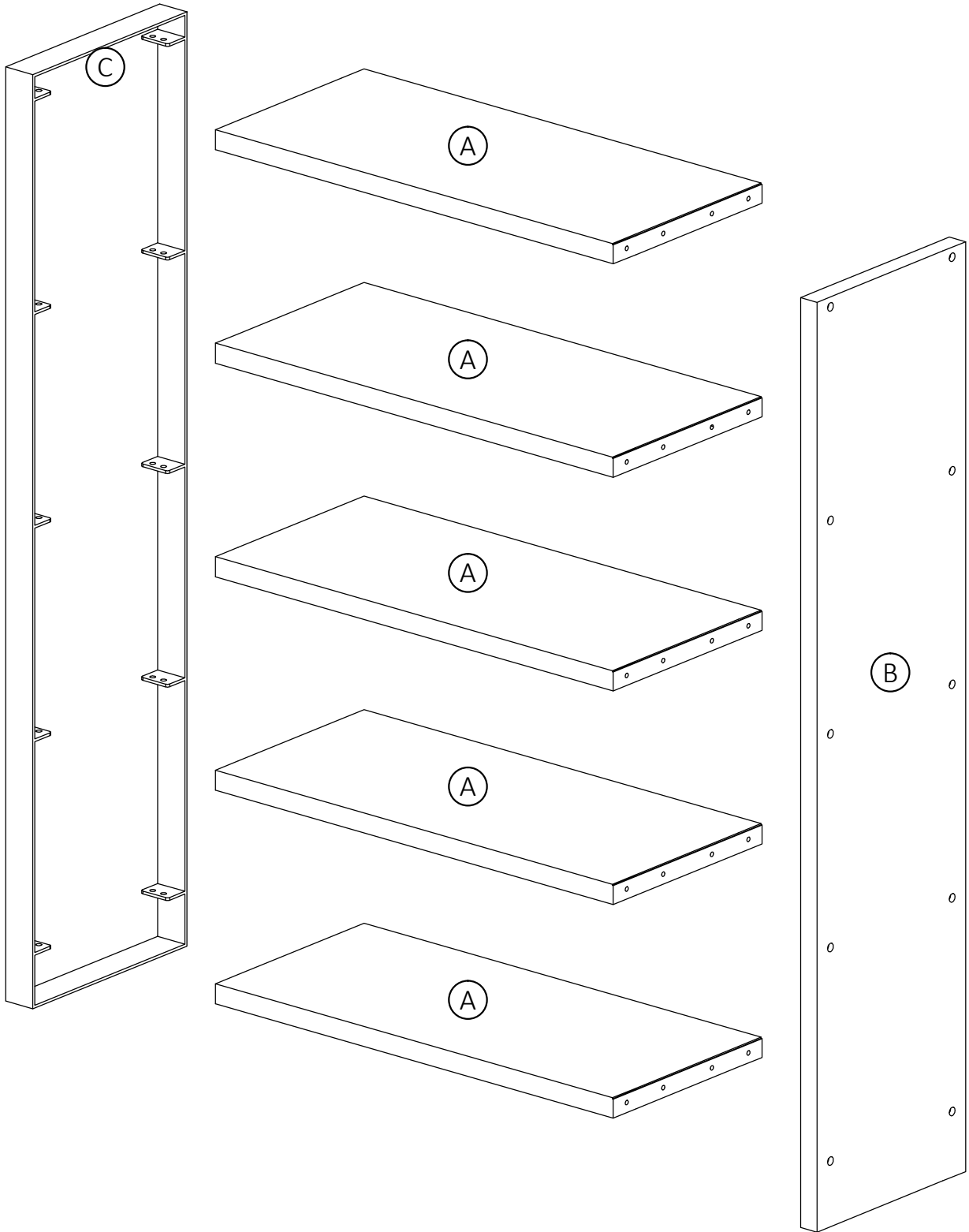

ASSEMBLY

STEP-1

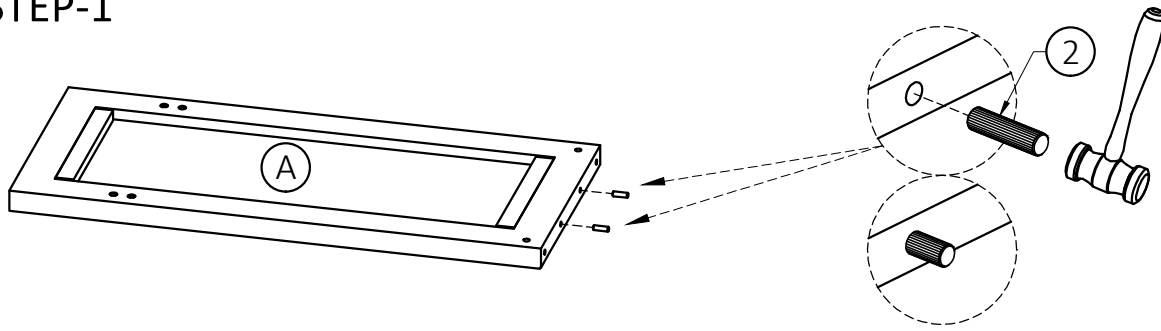

1. Insert two Wood Dowels (2) into guide holes on Shelves (A) .
2. Use rubber mallet to tap Dowels (2) into bottom of holes securely. 1/2 length of Dowels should be exposed.

STEP-2

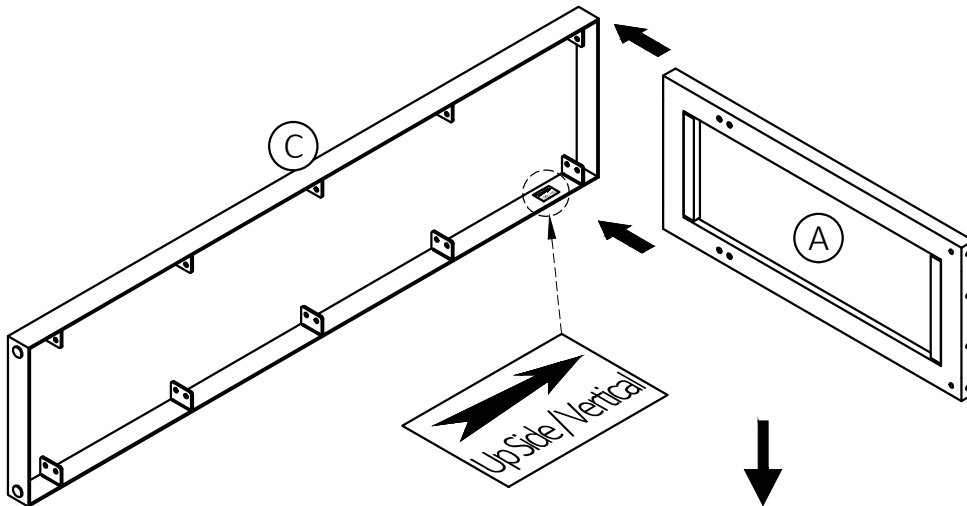

1. Insert one Shelf (A) to the top floor of Leg (C) .

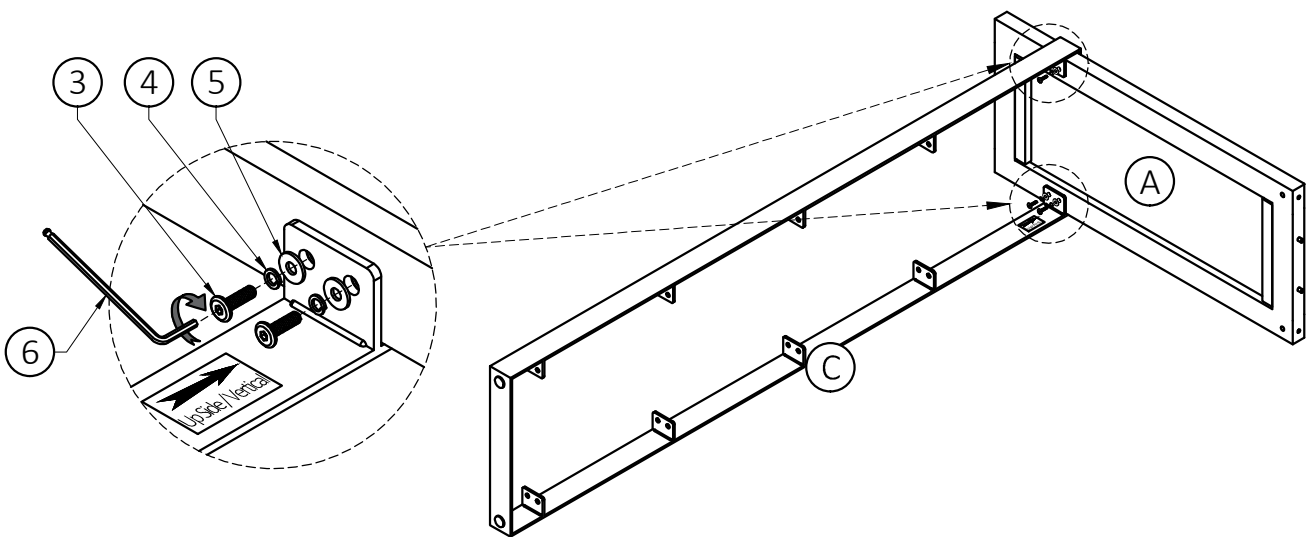

2. Use four Allen Key Bolts (3) , four Lock Washers (4) , and Washers (5) to secure Shelf (A) and Leg (C) .
3. Use Allen Key (6) to tighten Bolts. Do not over tighten.

ASSEMBLY

STEP-3

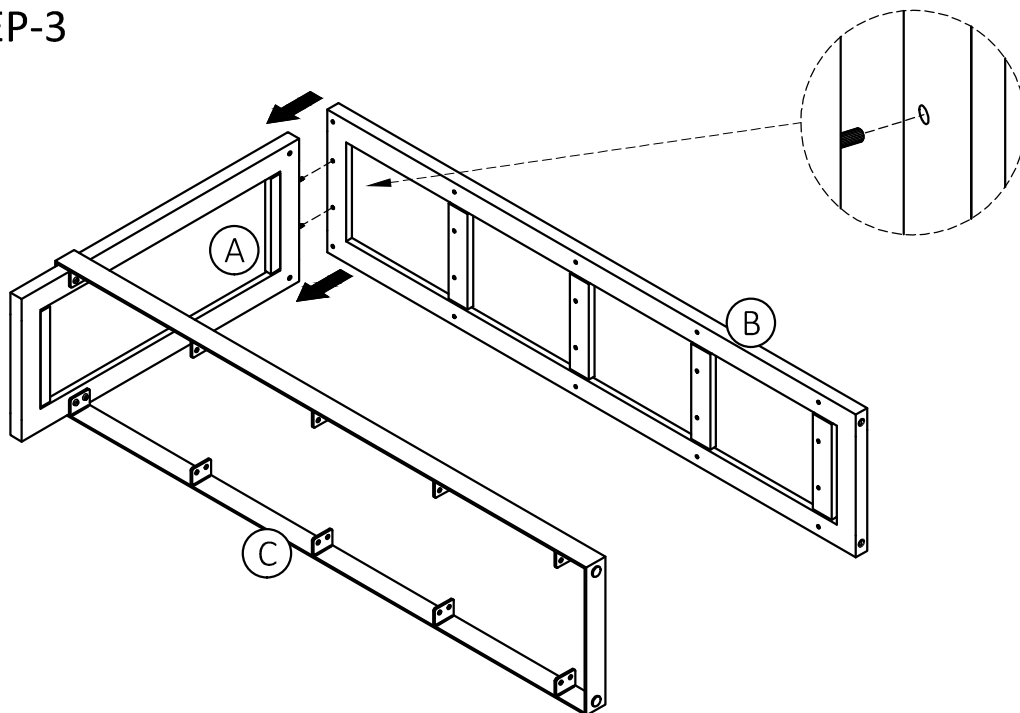

1. Align two guide holes on Side Panel (B) with two Wood Dowels on Shelf (A) and attach Side Panel (B) to Shelf (A).

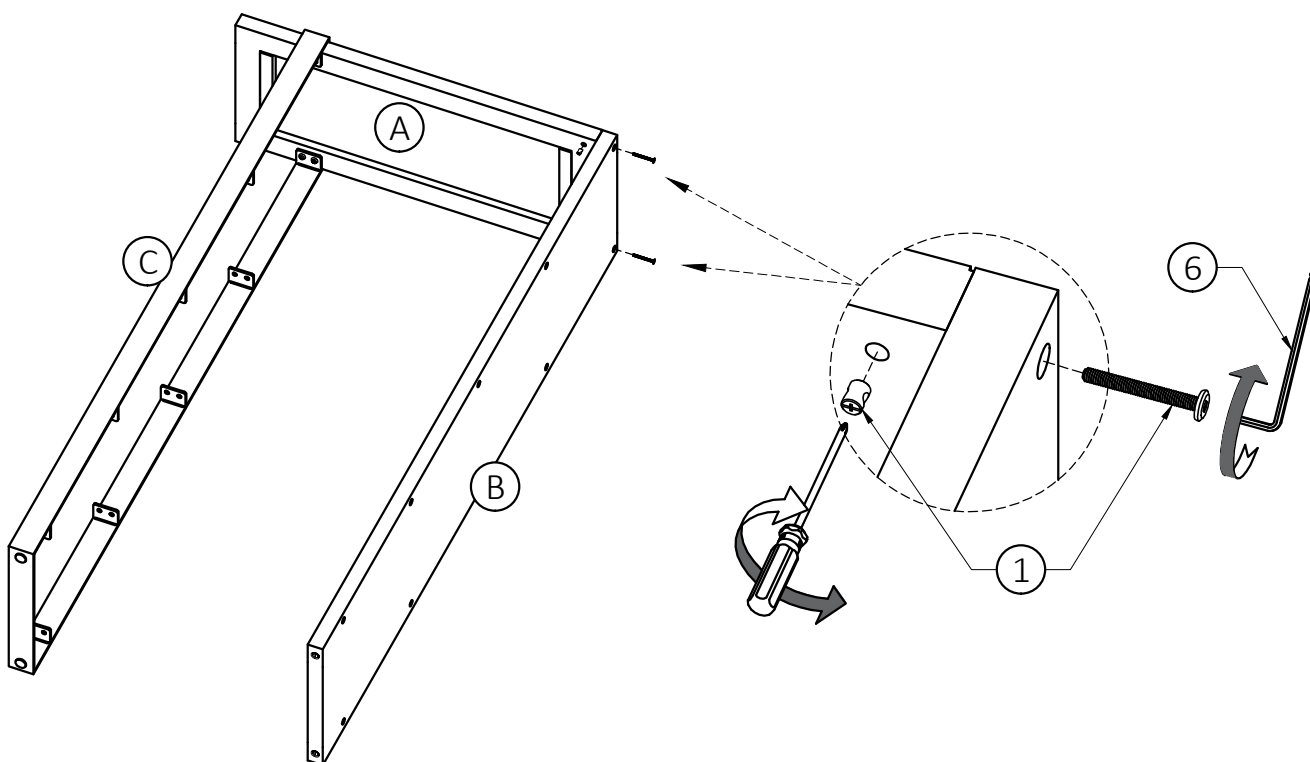

2. Attach Side Panel (B) with Shelf (A) by two sets of Bolt and Cross Nut (1).
3. Use Phillips screwdriver to adjust Cross Nut, then use Allen Key (6) to tighten Bolt.

ASSEMBLY

STEP-4

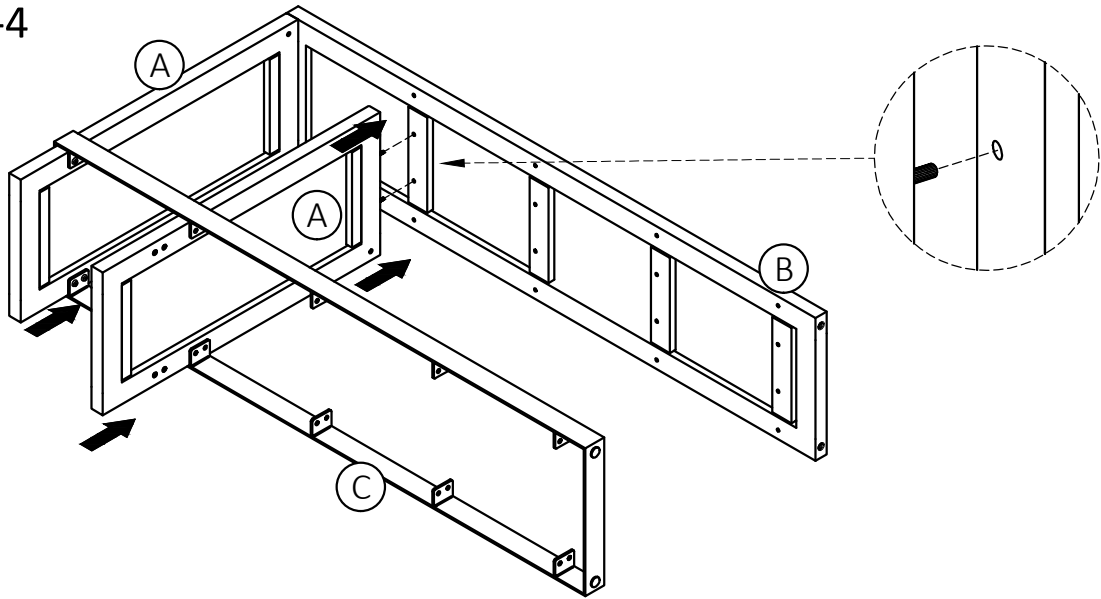

1. Insert the second Shelf (A) through Leg (C) and align two guide holes on Side Panel (B) with two Wood Dowels on Shelf (A) and attach Shelf (A) to Side Panel (B).

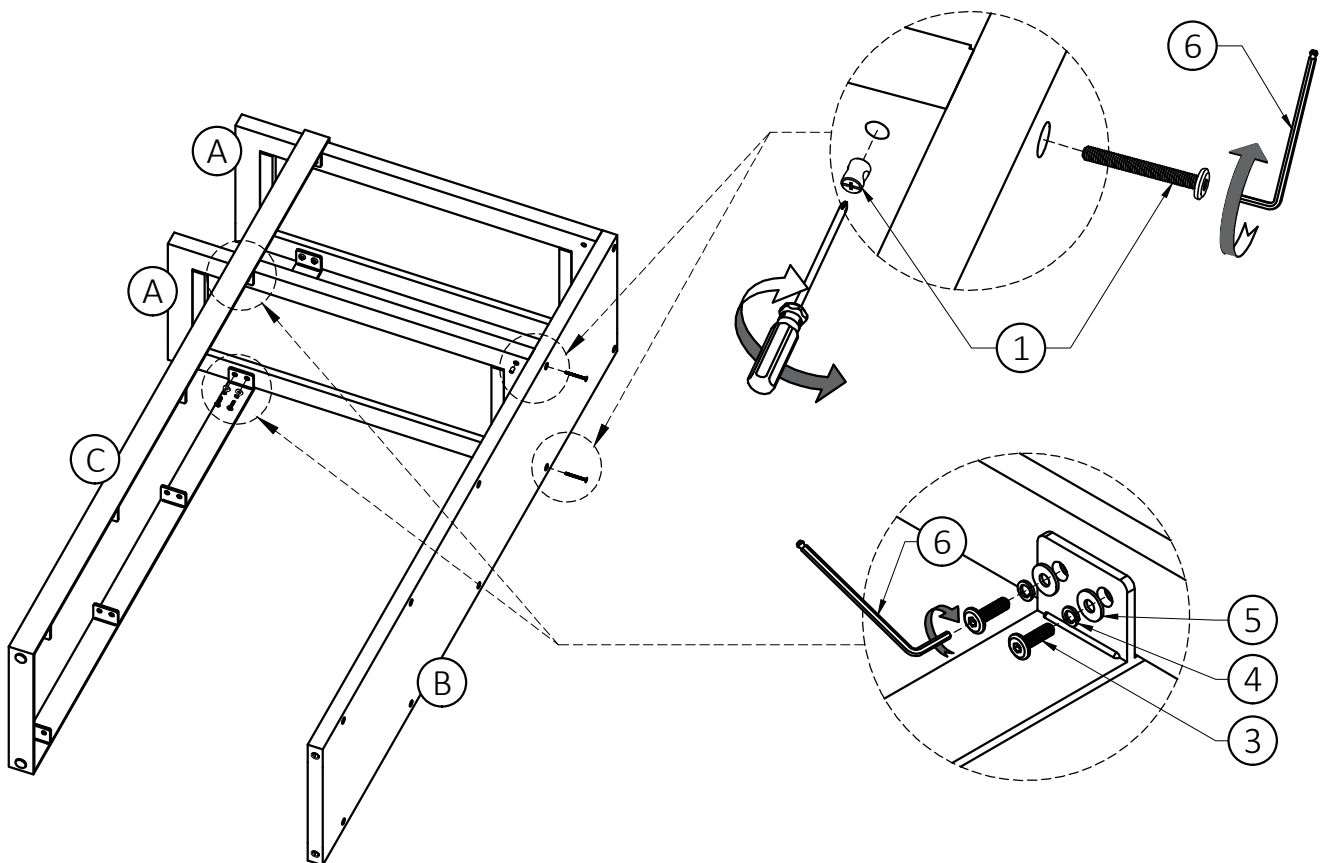

2. Attach Side Panel (B) with Shelf (A) by two sets of Bolt and Cross Nut (1).
3. Use four Allen Key Bolts (3), four Lock Washers (4), and Washers (5) to secure Shelf (A) and Leg (C).
4. Use Phillips screwdriver to adjust Cross nut, then use Allen Key (6) to tighten Bolt.

ASSEMBLY

STEP-5

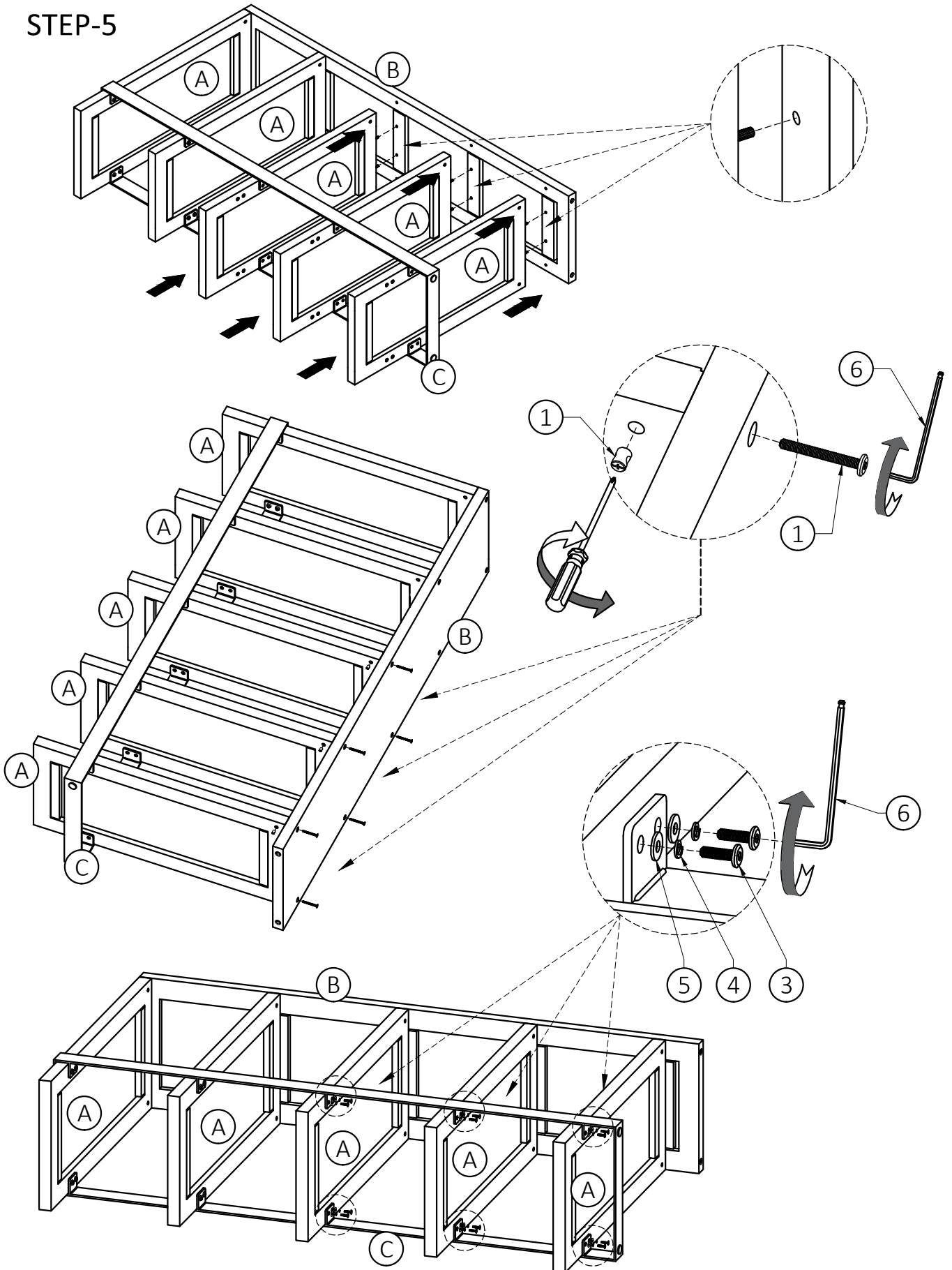

1. Repeat Step-4 for all the rest of Shelves (A).

ASSEMBLY

STEP-6

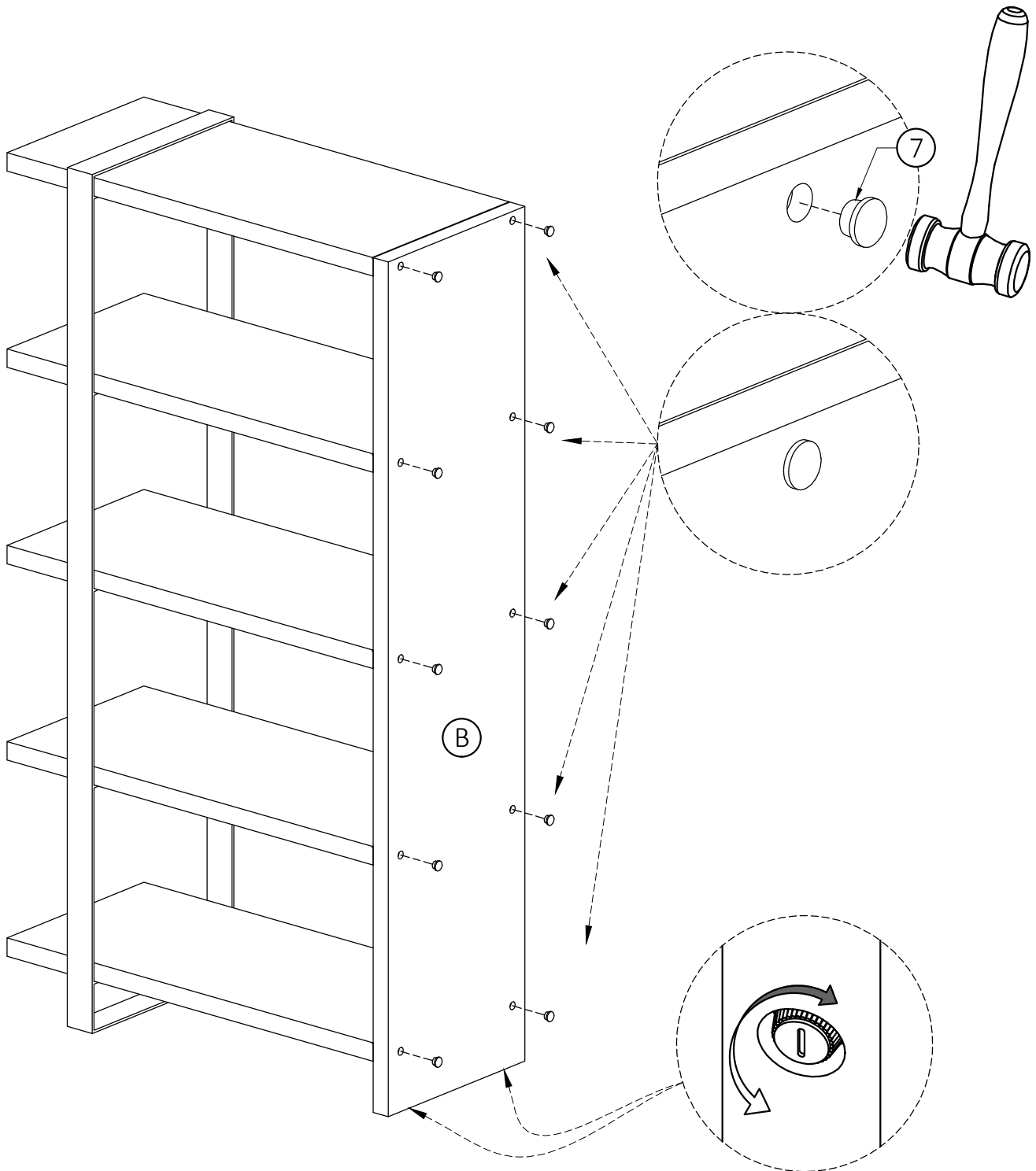

1. Insert Bolt Caps ⑦ into exposed bolt holes on Side Panel ②.
2. Use rubber mallet to tap Bolt Caps ⑦ into drilled holes securely.

Note: Levelers on bottom of Side Panel can be adjusted if floor is uneven.

FURNITURE TIP OVER RESTRAINT ASSEMBLY



WARNING

Serious or fatal crushing injuries can occur from furniture tip-over. If the furniture tip over restraint kit is not in the box, please contact our customer service department in order to obtain another kit before using the furniture.

STEP-7

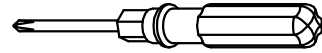

NOTE: The screwdriver is not included in the hardware pack.

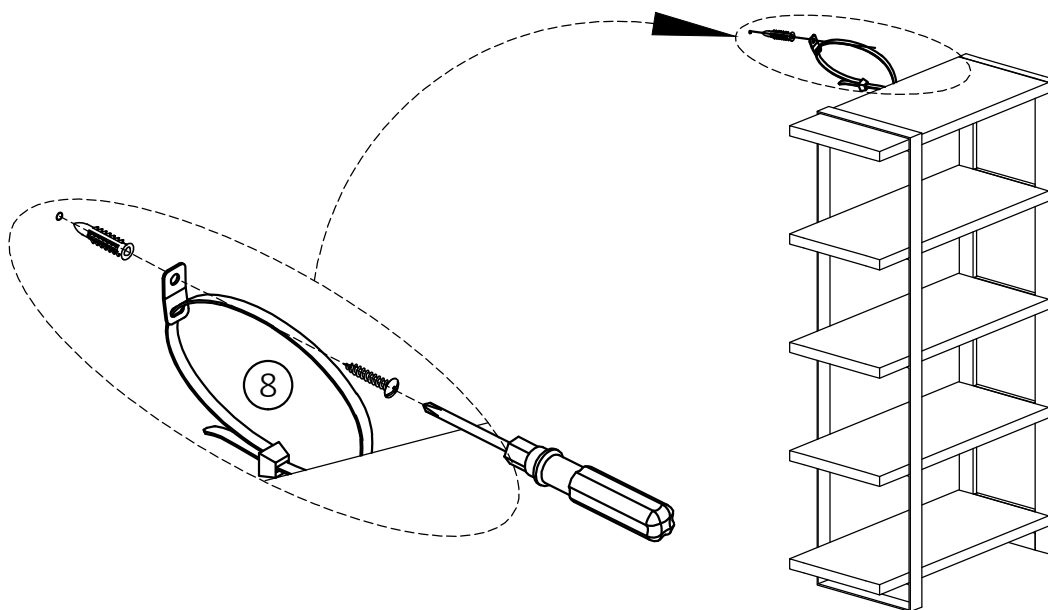
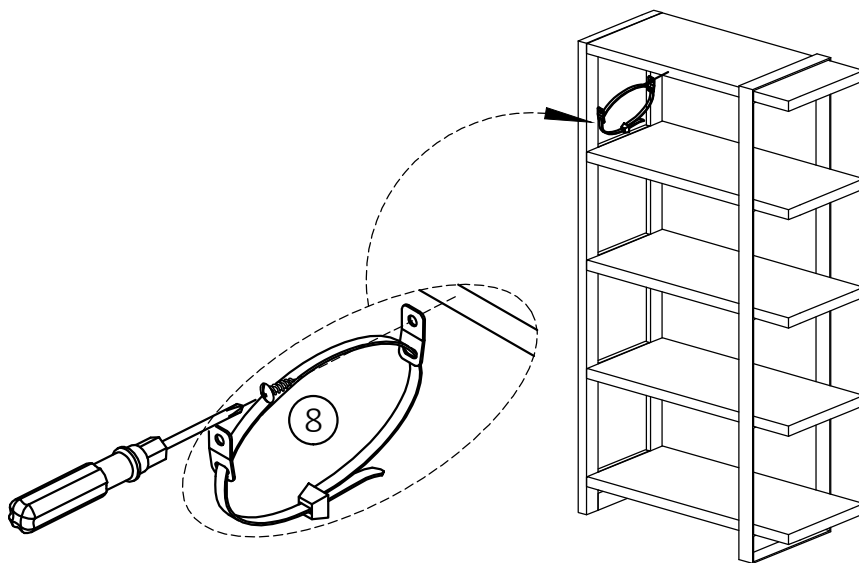

FURNITURE TIP OVER RESTRAINT ASSEMBLY

Furniture Tip Over Restraint Instructions:

1. Attach one of the mounting brackets securely to the back edge of the furniture. Use the shorter screw.

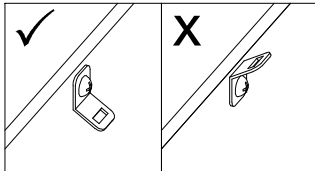

2. Determine where furniture is to be placed and mark location on the wall for mounting bracket screw hole approximately 2 inches **below** the bracket mounted to the furniture.

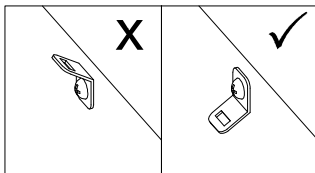

3. Drill a 3/16 inch hole in the wall. Press the plastic anchor into the hole and gently tap until the flange on the anchor is against the wall surface.
4. Position the bracket over the anchor and use the longer screw to securely attach the bracket to the wall.
5. Place the furniture so the back edge is in line with the bracket on the wall.
6. Lace an end of the nylon zip-tie strap down through each bracket. Bring both ends together and slide the smooth side upright through the square-shaped end and pull through to create the "locked" position.
7. Check to make sure the strap is securely laced and locked to the brackets.

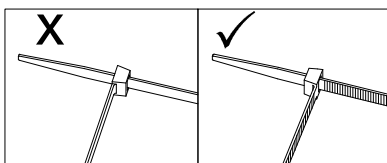

- **DO NOT** put a TV or other heavy objects on top of a chest of drawers or any other furniture not intended for use with a TV
- **DO NOT** place heavy objects in top drawers
- **DO NOT** let children climb or hang on drawers, doors or shelves

WARRANTY

Thank you for purchasing our product. These products have been made to demanding, high-quality standards and are guaranteed for domestic use against manufacturing faults for a period of 12 months from the date of purchase. This warranty does not affect your statutory rights.

In case of any malfunction of your product (failure, missing parts, etc.) please contact us at our toll free service line or by email.

We reserve the right to repair or replace the defective product, at its discretion.

This product is guaranteed for 12 months if used for normal purposes. Any warranty is invalid if the product has been overloaded or subject to neglect, improper use or an attempted repair by other than an authorized agent. Heavy-duty or daily professional/commercial usage are not guaranteed.

Due to continuous product improvement, we reserve the right to change the product specifications without prior notice.