

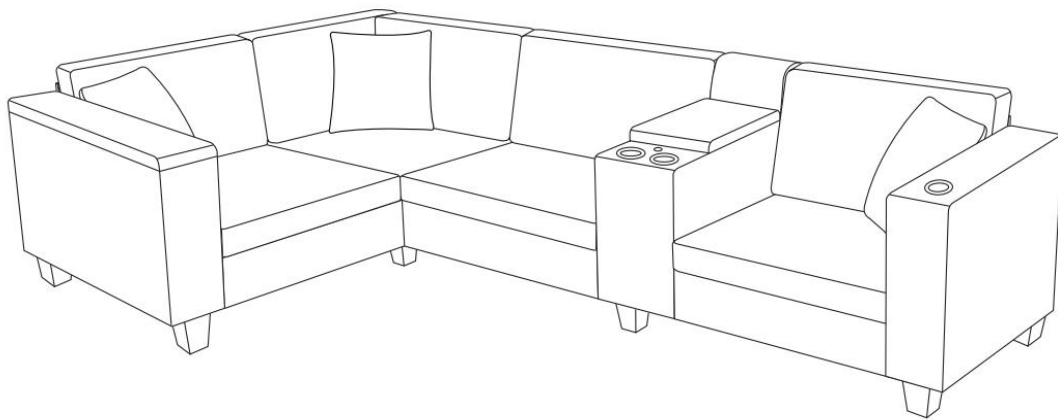

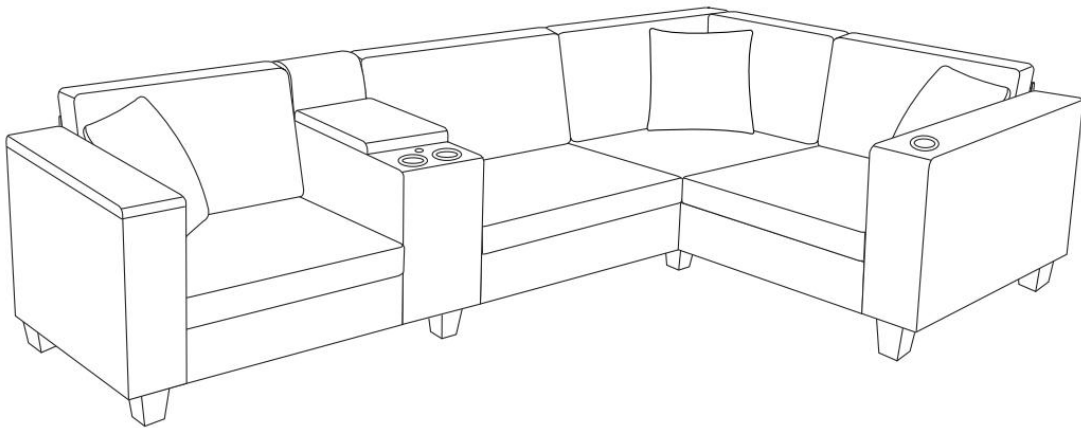



Assembly Instructions



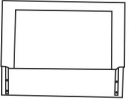

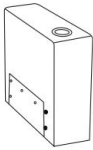
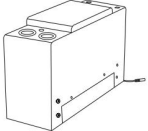
Note: Please help to read my instruction before you ready to assemble.

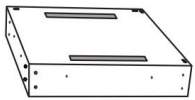
SOFA

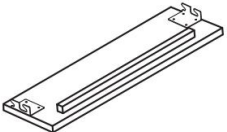
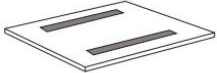

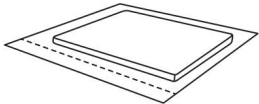
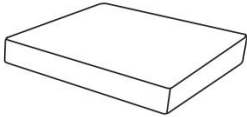



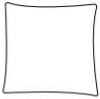





Part List

Label	Picture	Description	QTY (PCS)
A		Backrest	5
B		Left Armrest	1
C		Right Armrest	1
D		Center Console	1
E		Console Back Part	1
F		Corner Seat Frame	1
G		Back Rail	3
H		Front Rail	3
I		Seat Panel	3

J		Seat Cushion Package	4
J1		Seat Cushion	4
K		Back Cushion	4
L		Corner Back Cushion	1
M		Leg	10
N		Pillow	3

Hardware

①		Wood dowel	12
②		"L" Iron Connect Plate	6
③		Plastic Washer	10
④		Bolt (M8*20mm)	12
⑤		Bolt (M8*40mm)	20
⑥		Flat Washer	20
⑦		Spring Washer	20
⑧		Allen Wrench (S5)	1

⑨		Electrical Cord	1
⑩		Ratchet Wrench	1

NOTICE:

- Please read the instruction from cover to cover in detail.Thanks.
- Installed by at least two adults
- To avoid damaging your furniture , Please don't assemble on flooring or carpet.
- Please assemble on a clean non-marring surface, example for packing foam.
- Saving all packaging until have finished.

Assembly Steps:

OVERVIEW

Combination 1

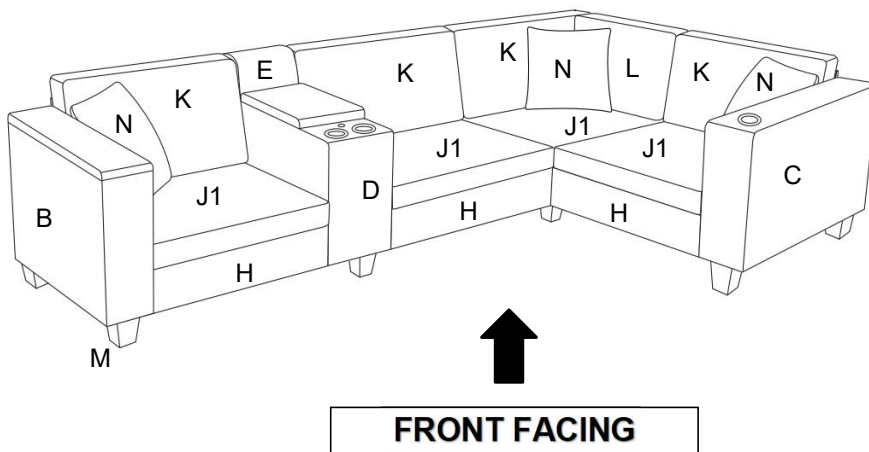

Combination 2

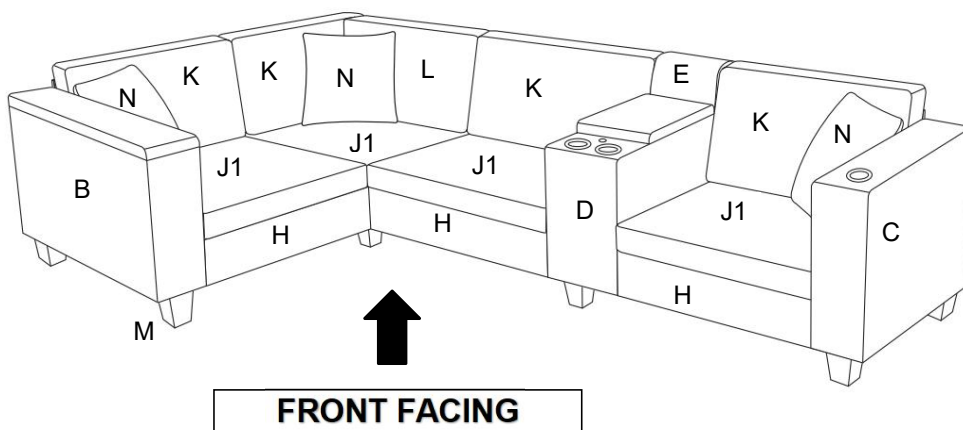

This SOFA has multiple parts and may require up to 45 minutes to assemble. To give you an overview of the SOFA parts, the above picture is to help you put the various parts into perspective. Please read through the instructions below to familiarise yourself with the parts and steps before assembly.
Note: It is recommended that you have an adult partner to assist during the entire assembly process.

Step 1

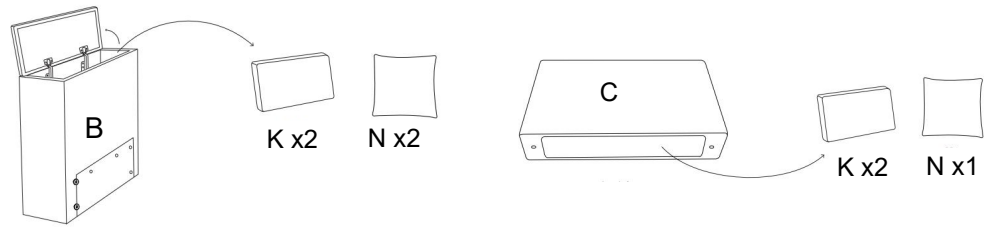

Respectively remove four Back Cushions(K) and three Pillows from Left Armrest(B) and Right Armrest (C).

Step 2

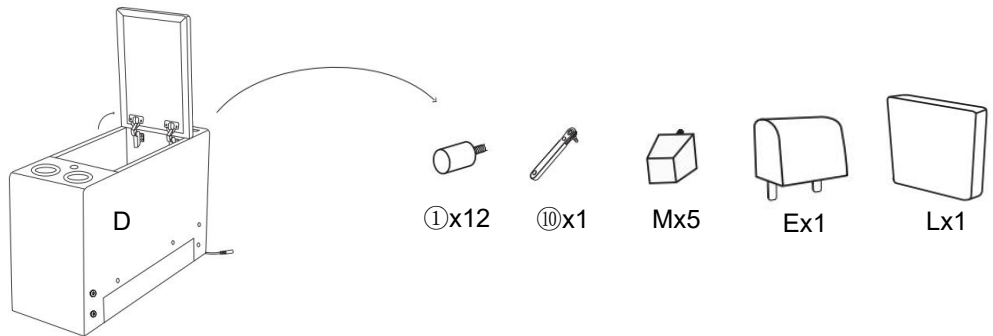

Remove Wood dowels (①), Ratchet Wrench(⑩), Legs (Mx5), Console Back Part(E), and Corner Back Cushion (L) from Center Console(D).

Step 3

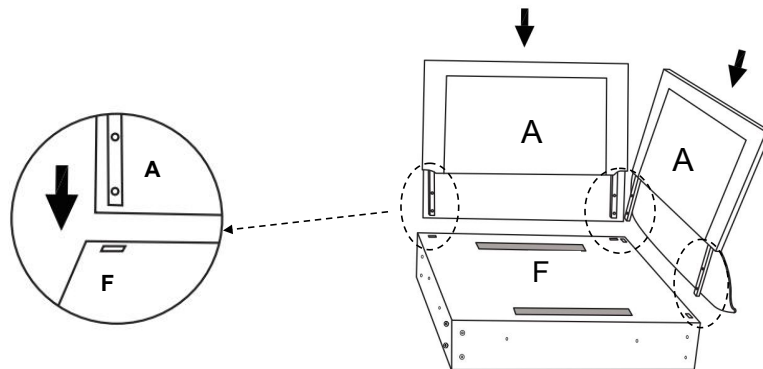

Insert the Backrests (A) into the Corner Seat Frame(F).

Step 4

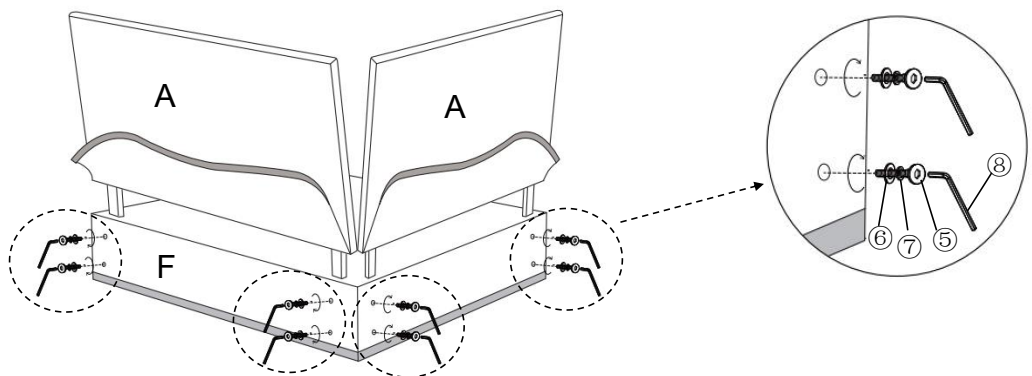

Use Bolt(⑤) Sping Washer (⑦) Flat Washer(⑥) with Allen Wrench(⑧), and turning clockwise until tight as shown.

Step 5

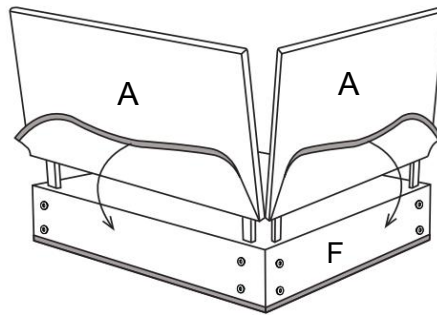

Attach the magic tape to the back of the Corner Seat Frame(F).

Step 6

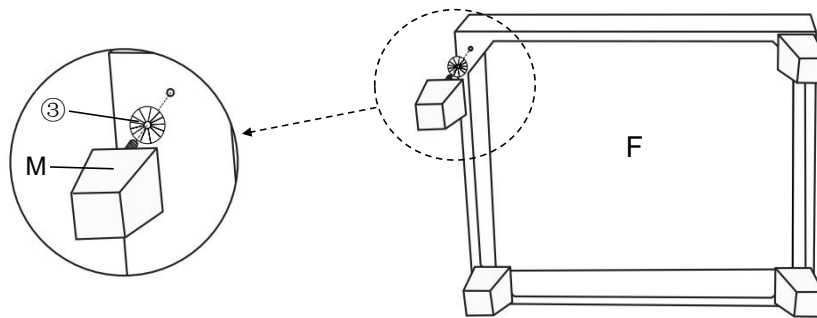

Install the Leg(M) at the bottom of Corner Seat Frame(F) by placing Plastic Washer(3) on the threaded stem. Then insert the threaded stem into the threaded mounting position at the bottom of Corner Seat Frame(F), turning clockwise until tight.

Note: The use of Plastic Washer(3) are OPTIONAL and are especially useful to help alleviate slight wobbleness. Some Legs may need more than one Plastic Washer(3) whilst some Legs may not need any.

Step 7

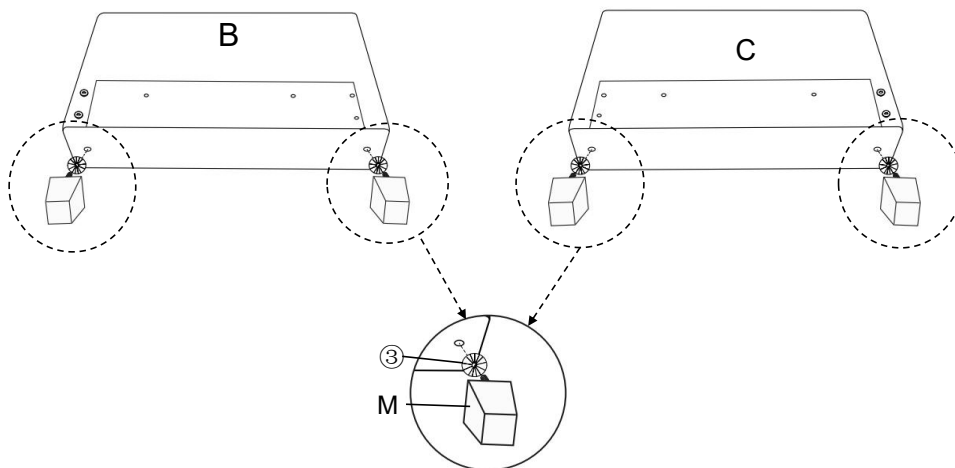

Repeat step 6 to install the Legs (M) on the Left Armrest(B) and Right Armrest (C).

Step 8

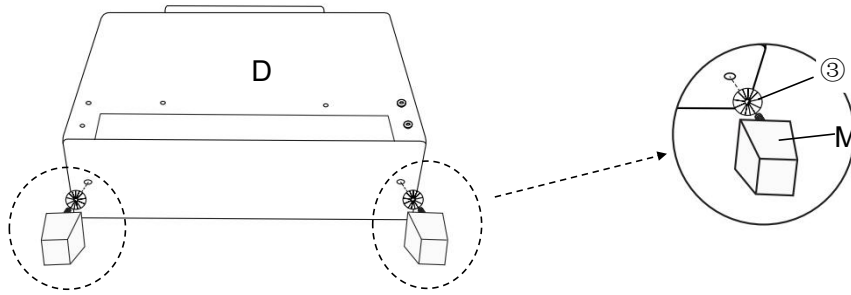

Repeat step 6 to install the Legs (M) on the Center Console(D).

Step 9

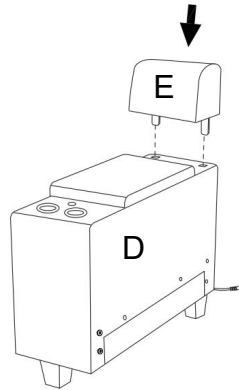

Insert the Console Back Part(E) into the Center Console(D).

Step 10

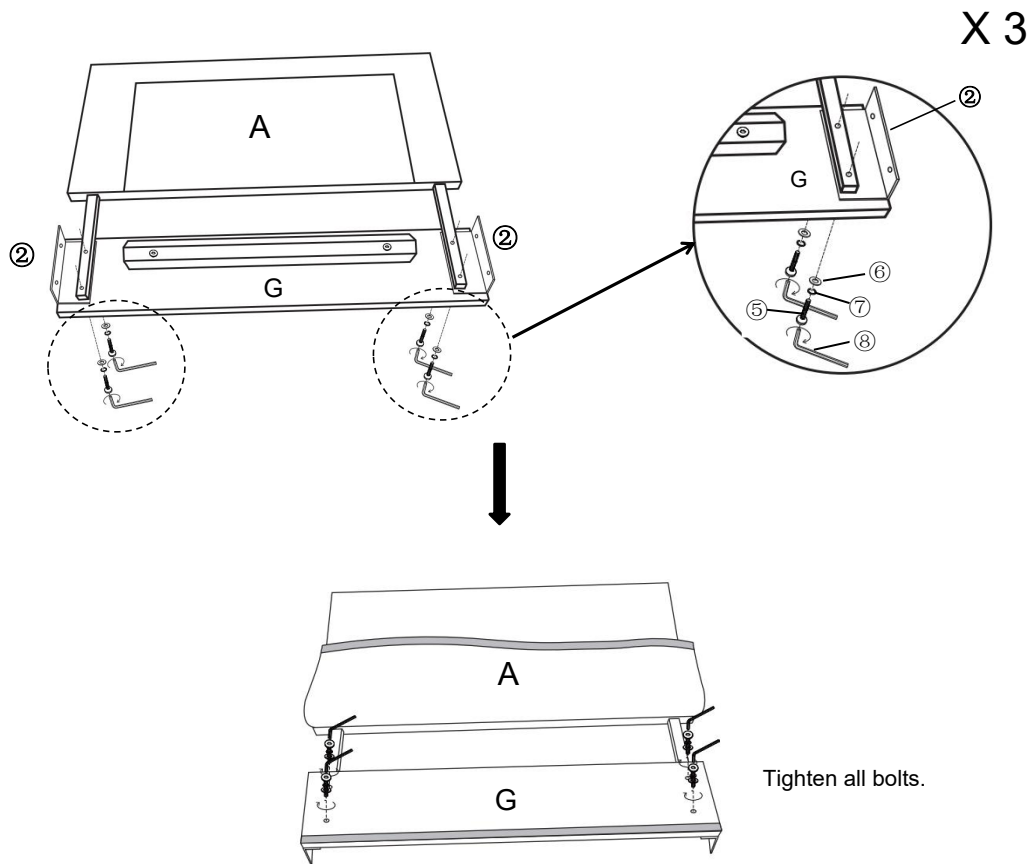

Install the Backrest(A) and Back Rail (G) by using "L " Iron Connect plate(2), then using Bolt(5) Sping Washer (7)Flat Washer(3) with Allen Wrench(8), then turn over and tighten all bolts clockwise. Repeat this step with the other two.

Step 11

Combination 1

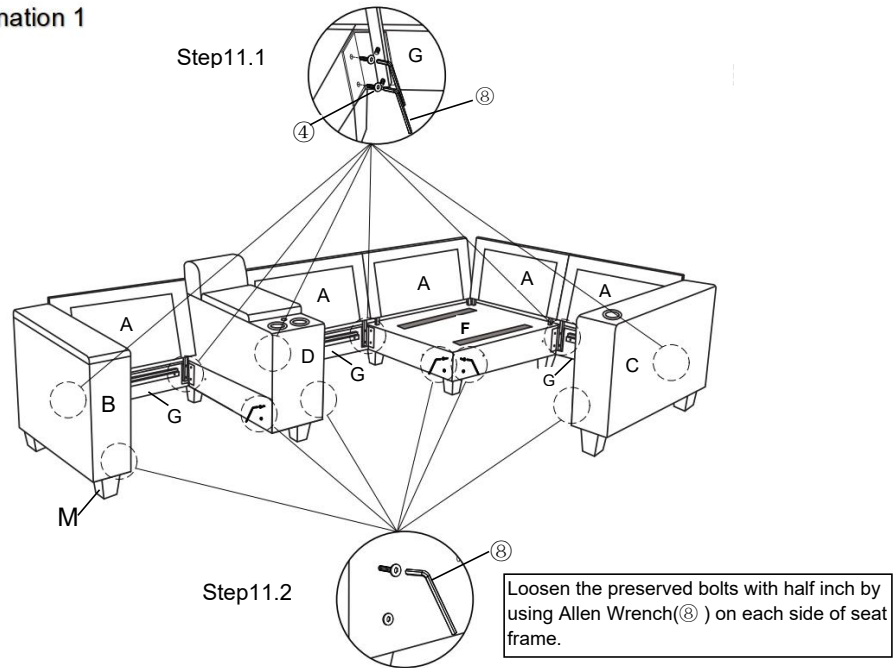

Combination 2

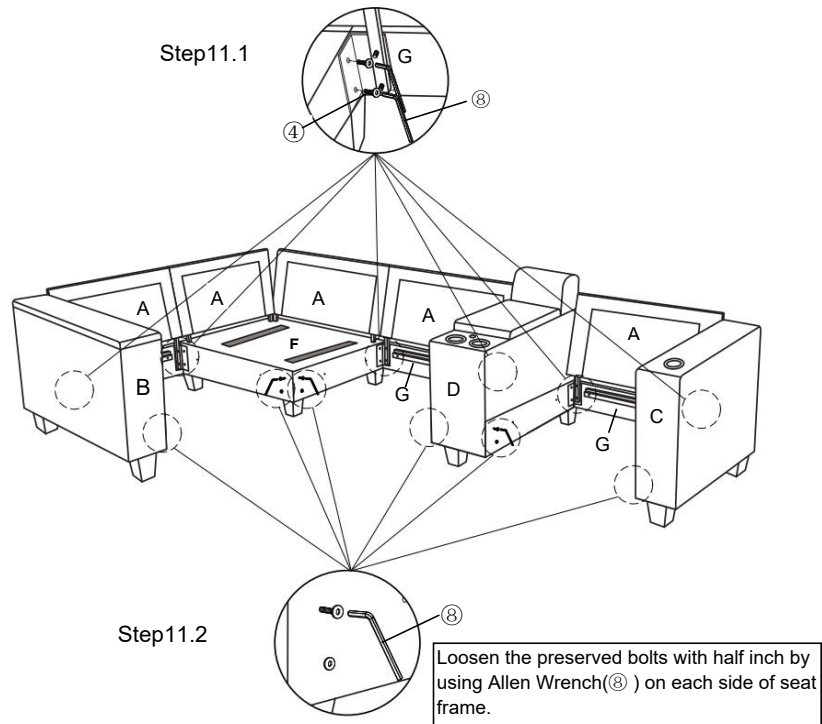

Step 11.1 Connect the Left Armrest (B), Center Console (D), Corner Seat Frame (F) and Right Armrest (C) with Semi-assembly Parts (Step 10) by using Bolt (4), with Allen Wrench (8), turning clockwise until tight.
Step 11.2 Loosen the preserved bolts with half inch by using Allen Wrench (8) on each side of seat frame.

Step 12

Combination 1

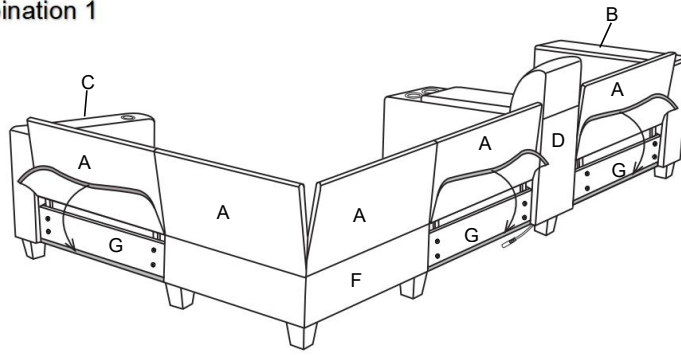

Combination 2

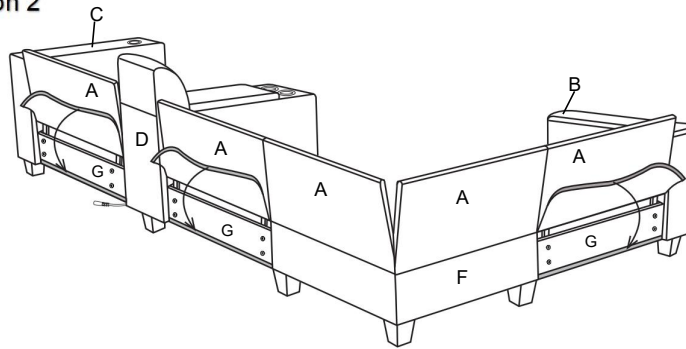

Attach the magic tape to the back of the Back Rail (G).

Step 13

Combination 1

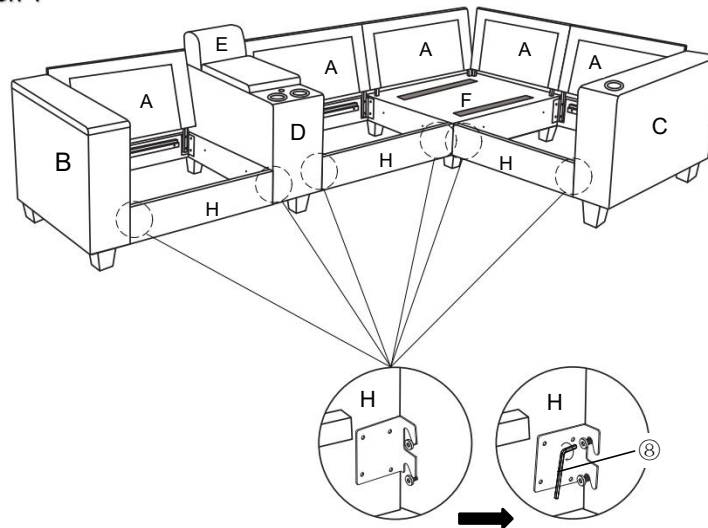

Combination 2

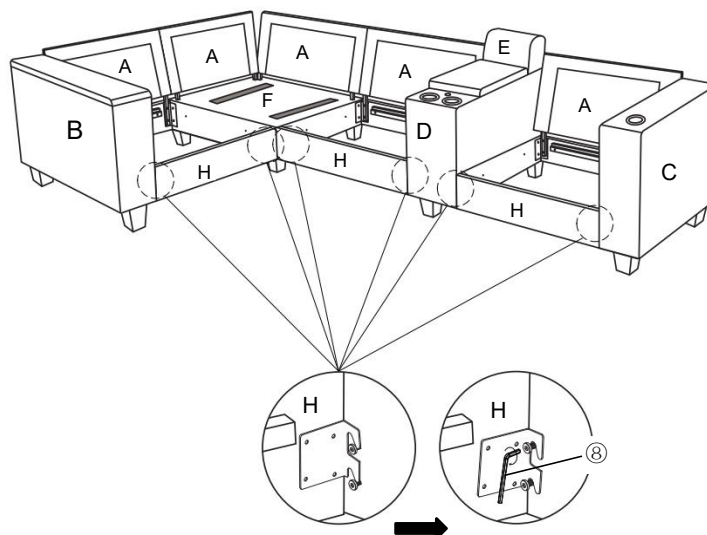

Slide the hook of Front Rail(H) into the bolts on the side of seat frame as picture shown, then tighten the bolts.

Step 14

Combination 1

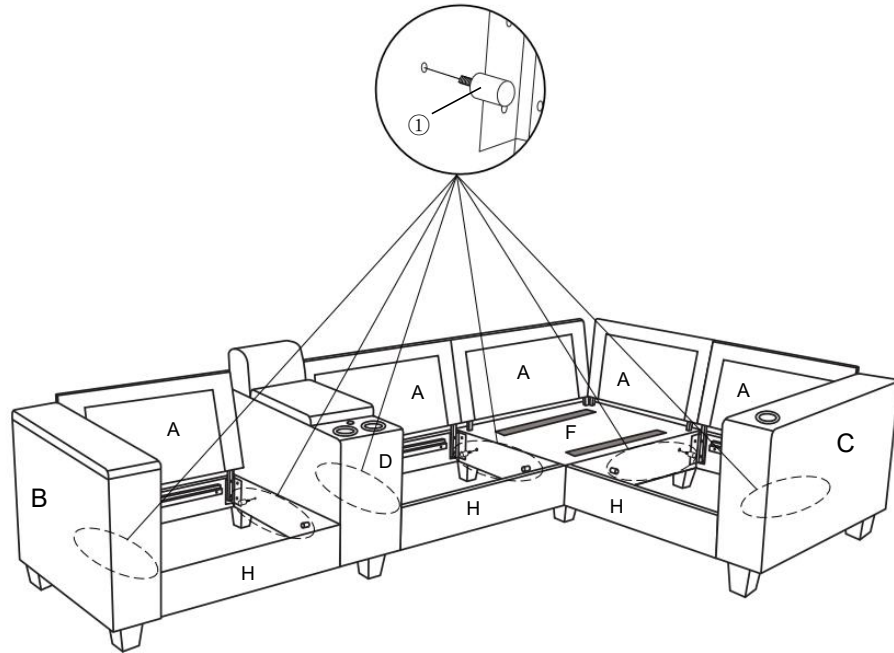

Combination 2

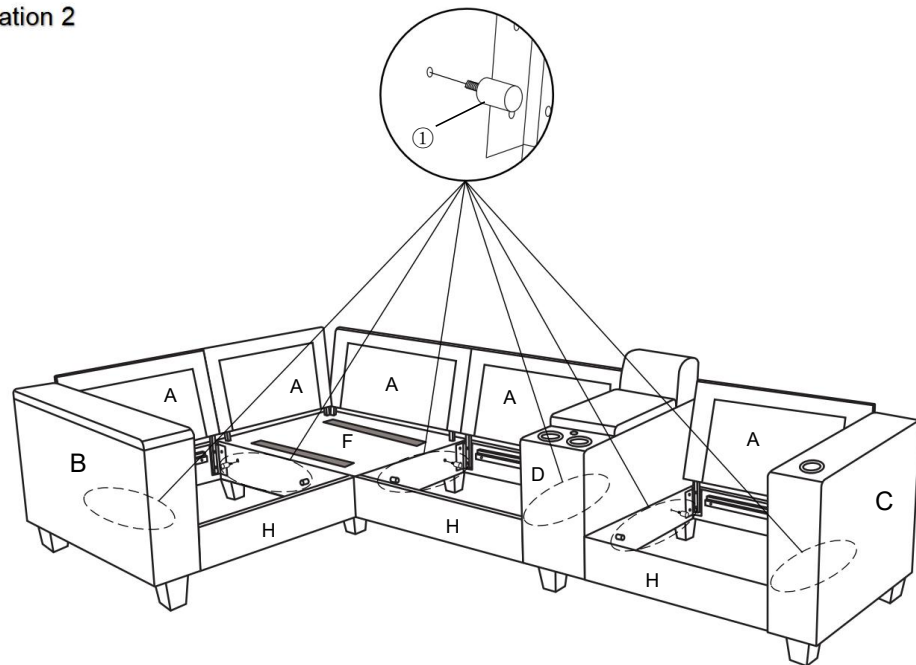

Install twelve Wood dowels (①) into the preformed hole of Left Armrest (B) ,Center Console(D), Corner Seat Frame(F) and Right Armrest (C) .

Step 15

Combination 1

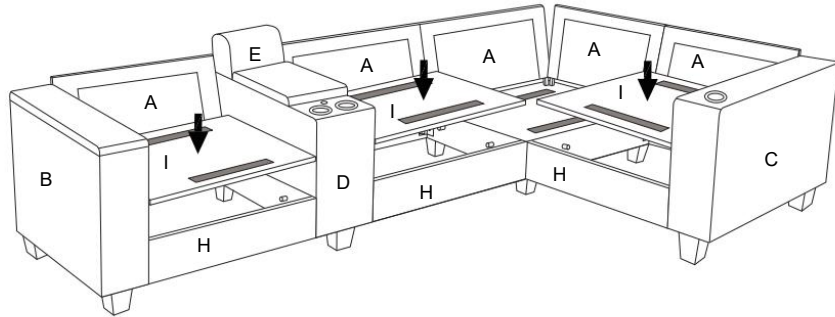

Combination 2

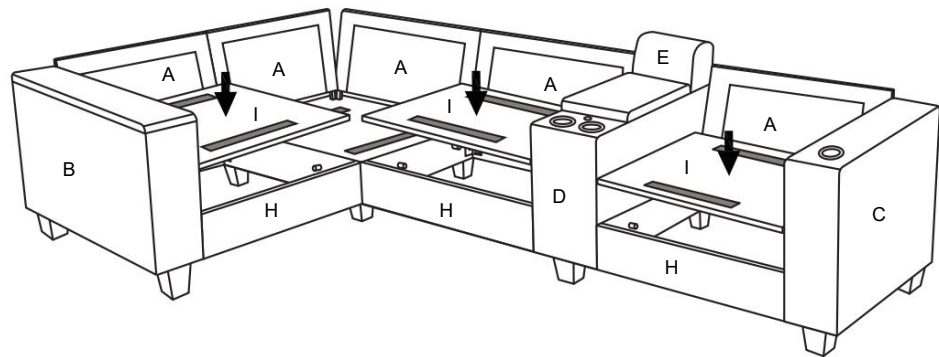

Put the Seat Panel (I) on the position.

Step 16

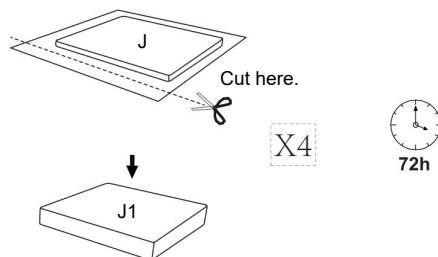

Cut the Seat Cushion Package (J) , then take out Seat Cushion (J1).Fully decompression may take up to 72 hours.

Step 17

Combination 1

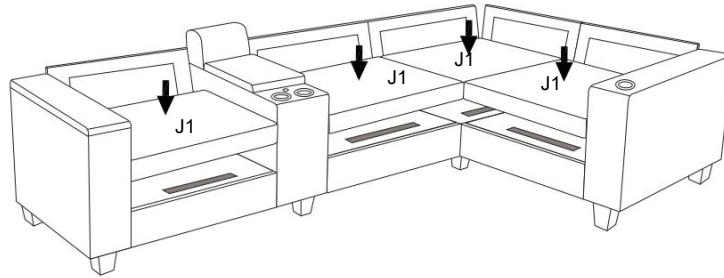

Combination 2

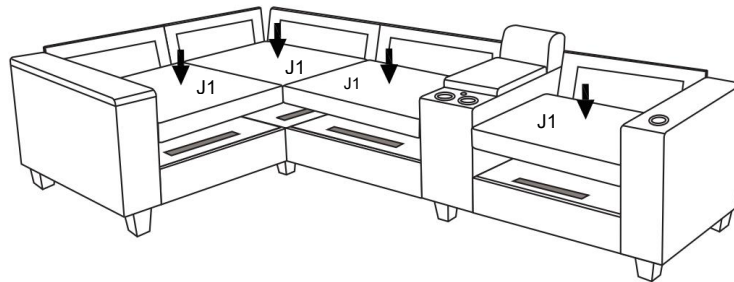

Put the Seat Cushions (J1) on your sofa.

Step 18

Combination 1

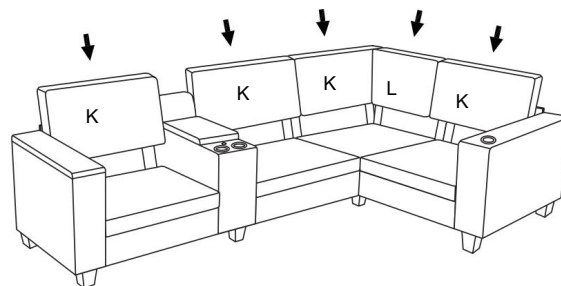

Combination 2

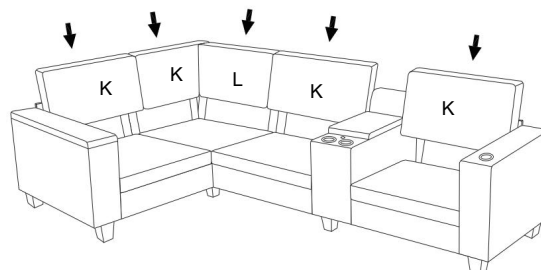

Put the four Back Cushions (K) and one Corner Back Cushion (L) on your sofa.

Step 19

Combination 1

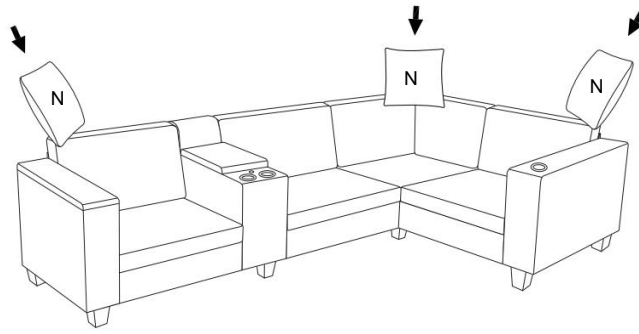

Combination 2

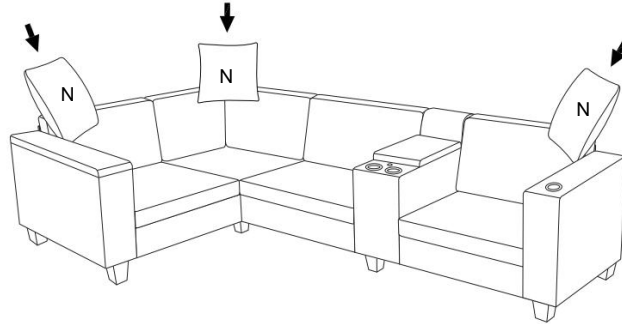

Put the three Pillows (N) on your sofa.

Step 20

Combination 1

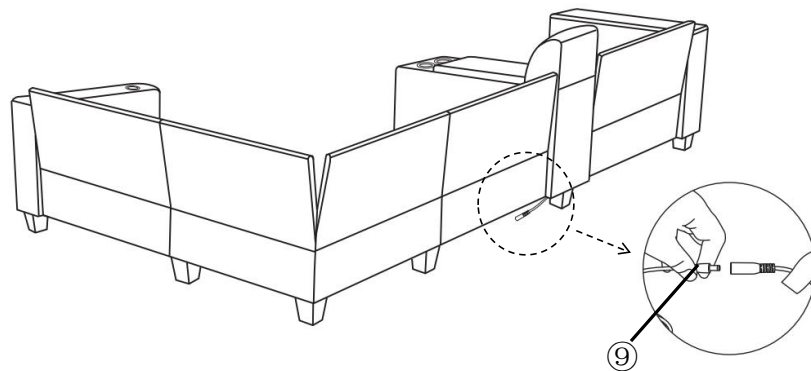

Combination 2

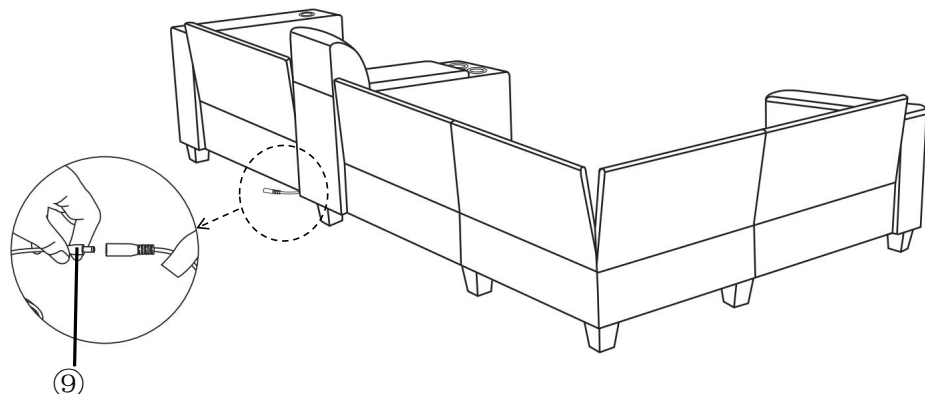

Plug in power by Electrical Cord(9) , then the USB is ready for use.

COMPLETE

Combination 1

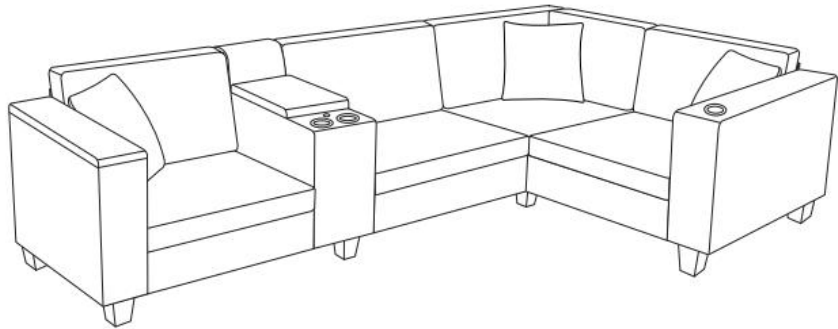

Combination 2

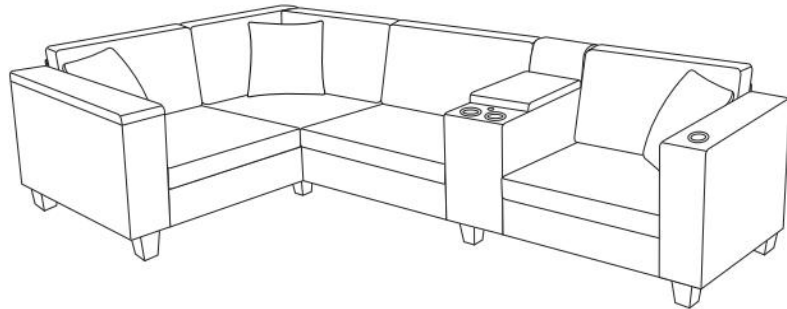

Your sofa is ready for use !