

## NOTICE

- \* Please make sure that you have all parts indicated and they are in good condition before you begin assembly of this item. Refer to part list and hardware list below for guidance.
- \* This item should be assembled on a soft surface to prevent scratching the finish during assembly.
- \* This item may require periodic tightening.
- \* If you are having difficulty, our friendly Customer Care team is always here to help. Please email us.

## PREPARATION

- \* Before beginning assembly of product, make sure all parts are present. Compare parts with part contents list and hardware contents list.
- \* If any part is missing or damaged, do not attempt to assemble the product.
- \* Estimated Assembly Time: 10 minutes.
- \* Tools Required for Assembly (included): Allen key.

## CARE AND MAINTENANCE

Adhesive felt pads should always be applied to areas of furniture which make direct contact with flooring, said application will prevent damage to the furniture and or surfaces on which the furniture lies. Objects placed on articles of furniture should rest on non abrasive material as to prevent damage to the wood finish. Objects whose composition consist of plastic and rubber are known to discolor and damage the wood surfaces on which they rest. Wipe up spills immediately and avoid common hazards such as hot dishes, harsh solvents and abrasives. Cleaning should be done with a soft lint free cotton cloth dampened with water or furniture polish. On highly used surfaces we recommend applying a quality paste wax which should be used on a regular basis to provide additional protection from scratches and spills. How often you apply the wax depends on how much the furniture wears.



# OWNER MANUAL

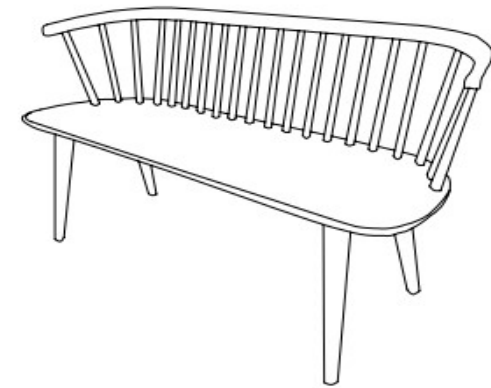



PRODUCT DIMENSION: 52.55" W X 19.4" L X 31.2" H



Weight Capacity: 450LBS  
WARNING: DO NOT STAND ON CHAIR

### Part List and Hardware List

PIECE	DESCRIPTION	PICTURE	QUANTITY
A	CHAIR BACK		1X
B	LEGS		4X

PIECE	DESCRIPTION	PICTURE	QUANTITY
HW1	ALLEN KEY M4		1X
HW2	JCBC BOLT M6 X 60MM		8X
HW3	SPRING WASHER M6 X 1/4		8X
HW4	FLAT WASHER 1/4 X 16		8X
HW5	FOOT PAD		4X

## PREPARATION

- \* Before beginning assembly of product, make sure all parts are present. Compare parts with part contents list and hardware contents list.
- \* If any part is missing or damaged, do not attempt to assemble the product.
- \* Estimated Assembly Time: 10 minutes.
- \* Tools Required for Assembly (included): Allen key.
- \* If you are having difficulty, our friendly Customer Care team is always here to help. Please email us.

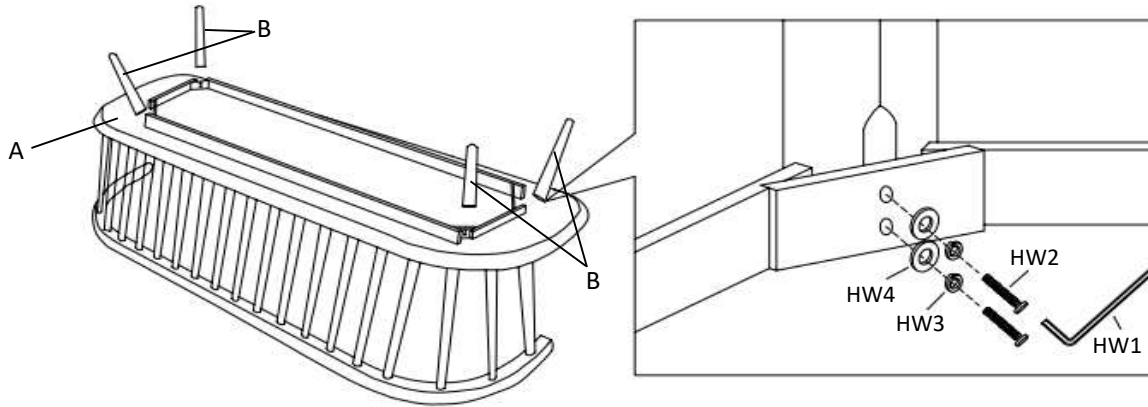

### STEP 1: Attach Legs to Chair Base

- Place the Chair Back (A) upside down on a soft surface.
- Align one Leg (B) to the corresponding corner.
- Insert one Flat Washer (HW4), one Spring Washer (HW3), and one JCBC Bolt (HW2) through the pre-drilled hole of the leg into the base.
- Use Allen Key (HW1) to tighten the bolt.
- Repeat this for the remaining three legs (B).

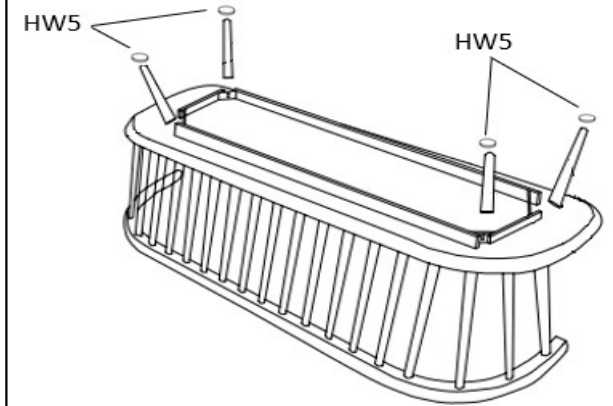

### STEP 2: Attach Foot Pads

- Peel off the adhesive backing from the Foot Pads (HW5).
- Stick one pad to the bottom of each Leg (B), centering it for balance.

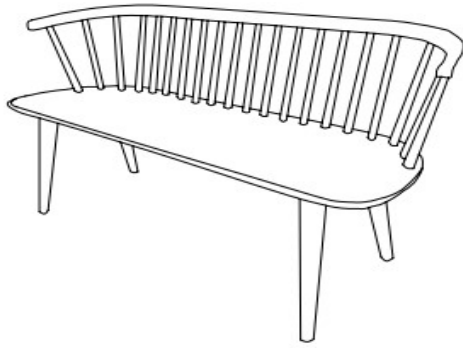

**STEP 3: Final Check**

- Make sure all bolts are fully tightened and secure.
- Carefully turn the chair upright and place it on a flat surface.
- Check for any wobbling or unevenness.
- If needed, adjust the bolts to ensure stability.
- Once stable, the chair is fully assembled and ready for use.