

NO	Part	Qty
1	Headboard	1
2	Right bedside	1
3	Left bedside	1
4	Footboard	1
5	Sprung base	1
6	Angle Iron	2
7	Metal Legs	6

HARDWARE FOR BED

NO	Part	Qty
A	Nut M8	8
B	Threaded Bolt M8x65	4
C	Screw M6x18	8
D	Screw M6x45	8
E	Gasket M8	4
F	Gasket M6	8
G	Spanner M8/13mm	1
H	Maxiluna Washer Ø40x15	8
I	Threaded Bolt M8x110	4
J	Cover Cap Ø40	8
K	Spanner	1

HARDWARE FOR BEDFRAME

NO	Part	Qty
E	Gasket M8	24
A	Nut M8	12
M	Screw M8X20	4
N	Screw M8X45	8

- Please check contents and read instructions before commencing assembly.
- Please use a soft mat to avoid damaging during assembly
- Assemble this article following the enclosed instructions carefully.

	30min		X2



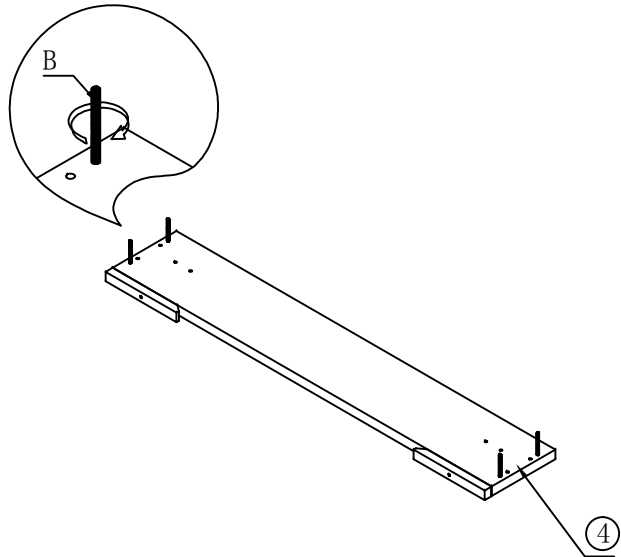

STEP 1

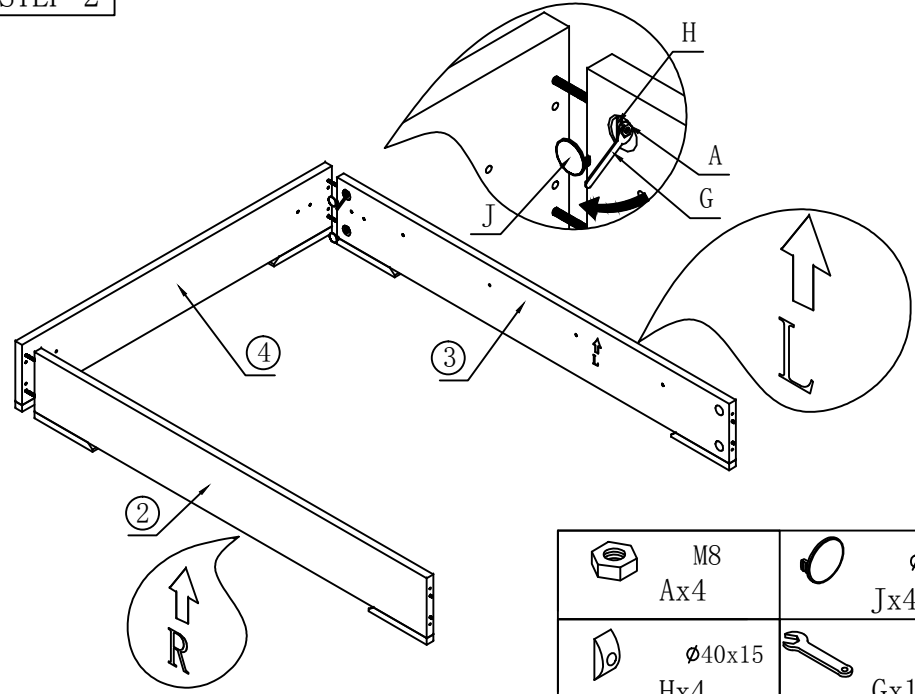

	M8x65 Bx4
---	--------------







STEP 2

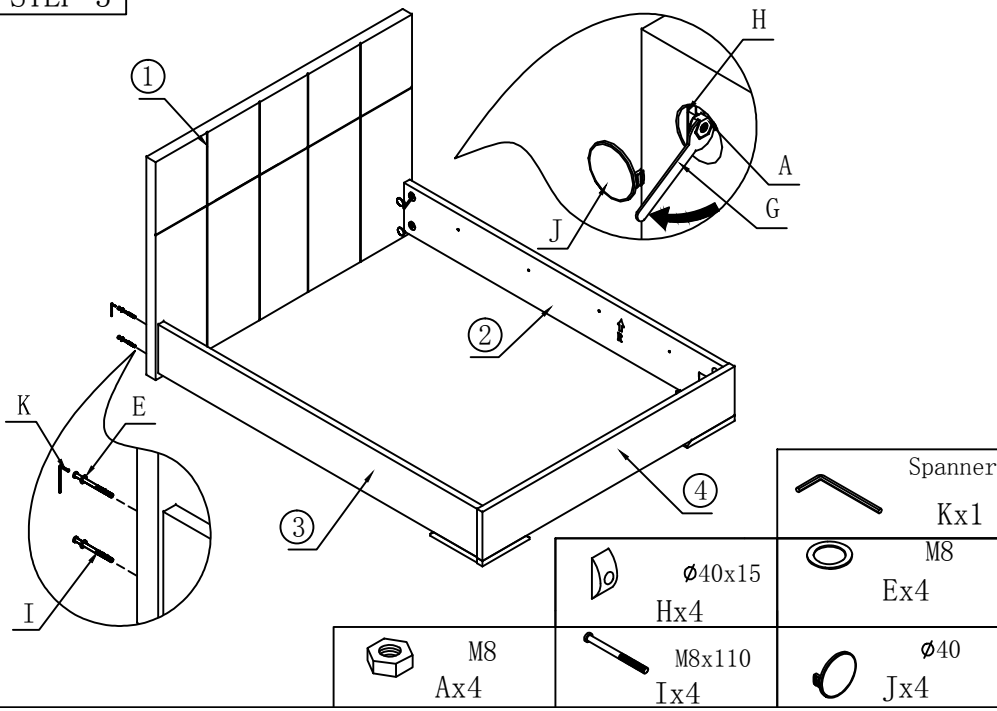

	M8 Ax4		ø40 Jx4
	ø40x15 Hx4		Gx1

STEP 3



	Spanner Kx1		M8 Ex4
	ø40x15 Hx4		M8x110 Ix4
	M8 Ax4		ø40 Jx4

STEP 4

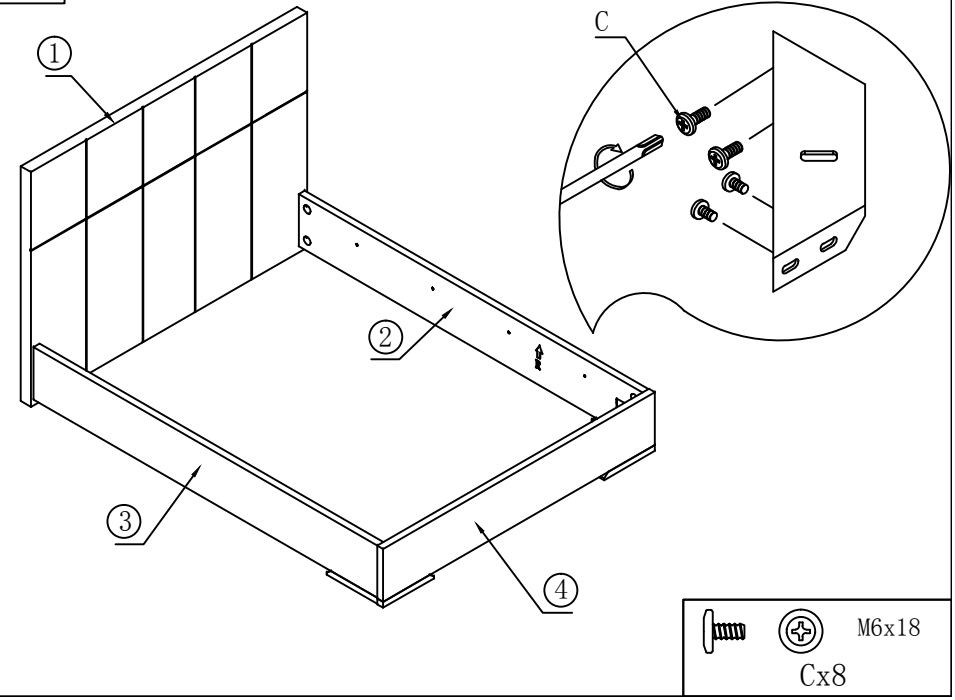

	M6x18 Cx8
---	--------------

STEP 5

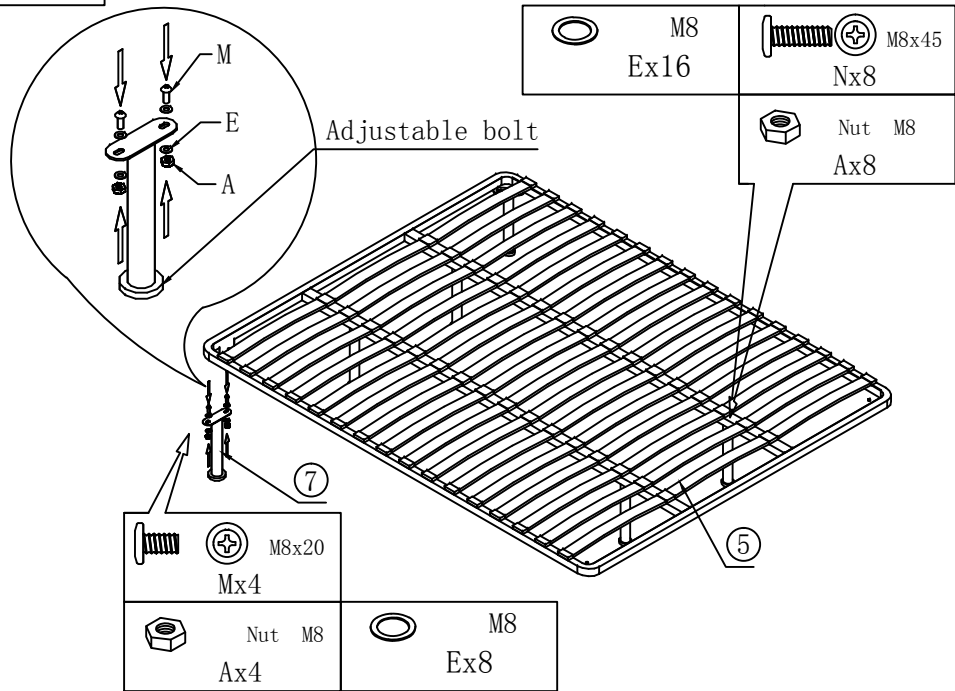

STEP 7

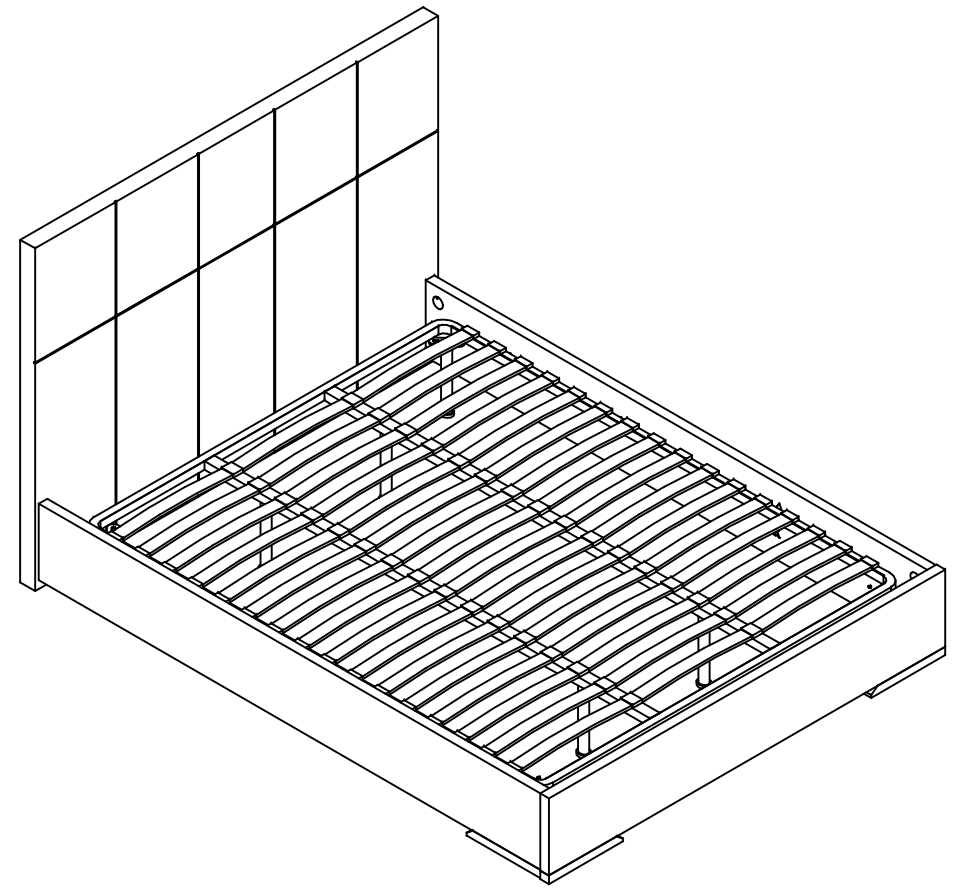

STEP 6

