

ASSEMBLY INSTRUCTION





Thank you for purchasing this quality product. Be sure to check all packing materials carefully for small parts which may have come loose inside the carton during shipment. Separate, identify and count all parts and metal hardware. Compare with parts list to be sure all parts are present. If any parts are missing or damaged, please contact your local furniture dealer. For efficient and speedy service, please indicate the model number and code letter of parts needed.

***** Do not fully tighten screws until fully assembled *****

COMPONENT PARTS

DESCRIPTION	PART NAME	QTY (PCS)
①	Cabinet body	1
②	Castor	4
③	Hold the handle	1
④	Layer board	2
⑤	Take the blue	1

HARDWARES REQUIRED

ⓕ		Screw 5/16" * 1"	16 PCS
ⓖ		Lock 5/16"	16 PCS
ⓗ		Flat Washer 5/16" * 22mm	16 PCS
ⓙ		Allen Wrench 5mm	1 PCS
Ⓚ		Layer board nail	8 PCS

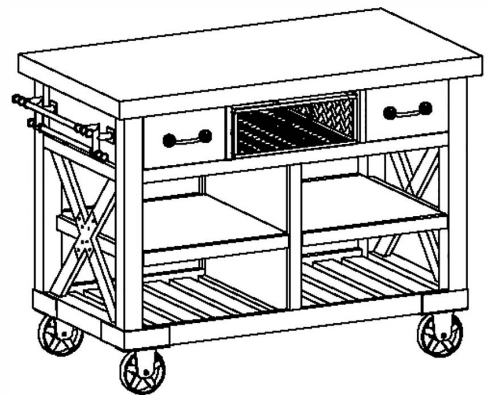

Attention:

***** Mattresses not included.**

***** Some number parts listed on the instruction sheet may not be in package as they may already be assembled**

Carefully check parts and packing materials prior to ordering replacements

STEP 1

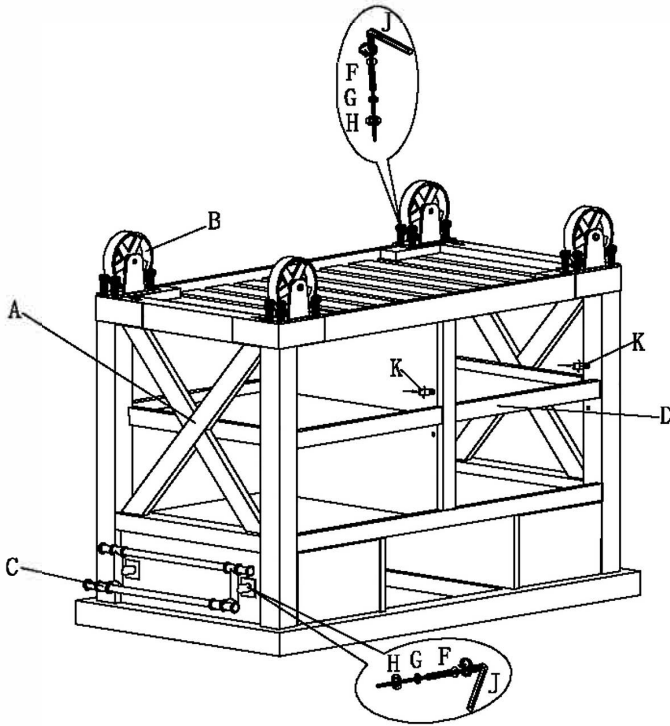

PARTS LIST:

NO	Description	Sketch	Quantity
A	Cabinet body		1 PCS
B	Castor		4 PCS
C	Hold the handle		1 PCS
D	Layer board		2 PCS
E	Take the blue		1 PCS

STEP 2

