

4 Tier Shelf

IMPORTANT NOTE

Carefully remove all the parts from the carton and put them individually on a soft cloth to prevent scratches or other damages occurring to the parts.

We have taken great care in the design of this product and request that you carefully and strictly follow our assembly instructions to ensure a completed product as it was designed.

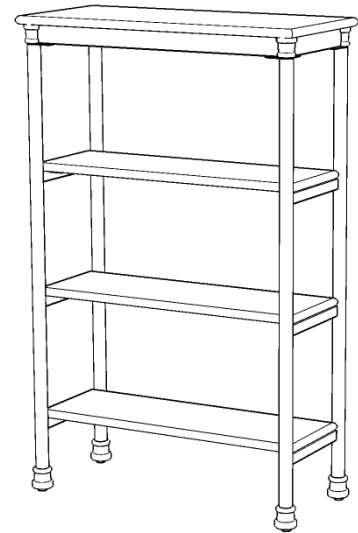

Part List



A.
Top
1 pc.

B.
Side Frame
1 pc.

C.
Side Frame
1 pc.

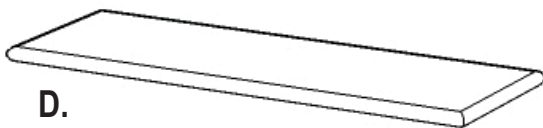

D.
Shelf
3 pcs.

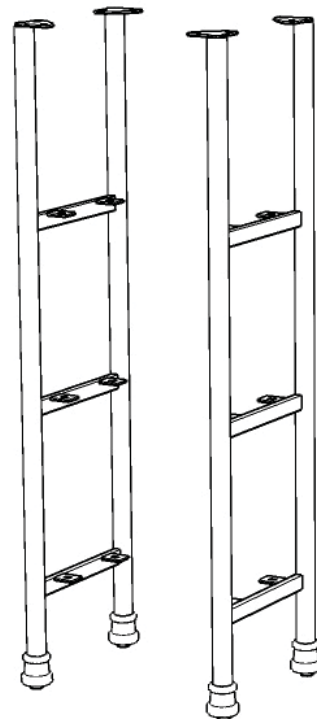

Hardware List



Hex Wrench
1 pc.



Small Hex Wrench
1 pc.



Spring Washer
12 pcs. (+1 extra)



Flat Washer
12 pcs. (+1 extra)



Head Cap Bolt
12 pcs. (+1 extra)



Head Cap Bolt (short)
8 pcs. (+1 extra)

Tools required for assembly : Phillips screwdriver

Tools recommended for assembly : Level

IMPORTANT

- * Do not tighten up all the screws until each part is properly assembled.
- * You should keep Hex Wrench in a safe place as you may need to tighten up the Head Cap Bolts in the future.
- * After assembly, item must be level to work properly. Use the included adjustable levelers to level.

STEP 1

Attach Side Frame (B) and (C) to Top (A) with Head Cap Bolt (short). (See Figure 1)

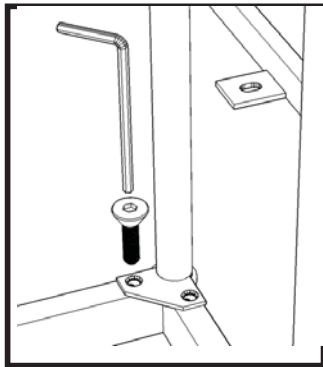
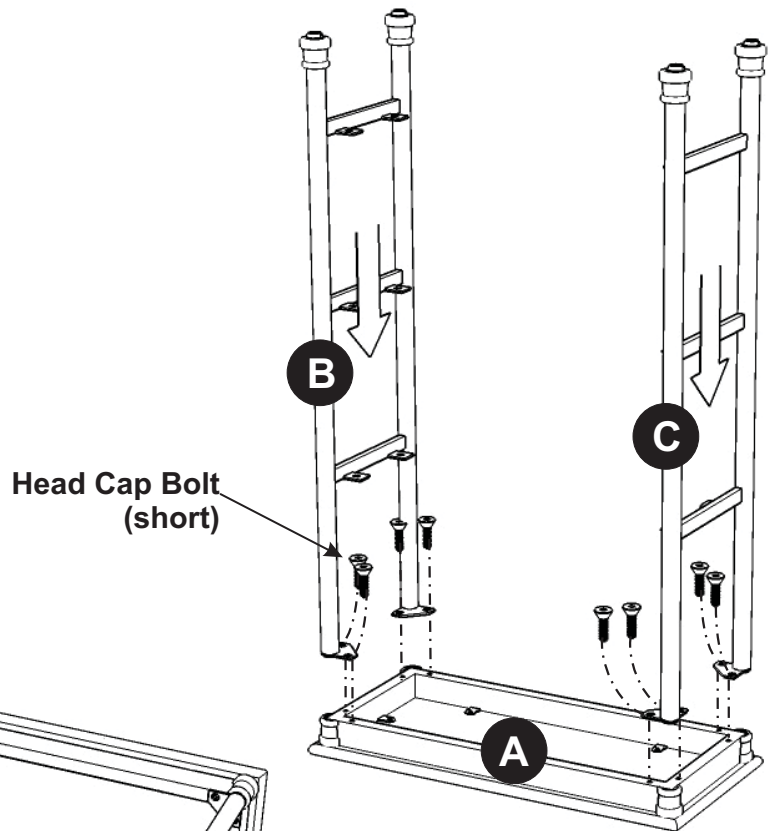

Figure 1



Head Cap Bolt (short)

STEP 2

Attach Shelves (D) to unit with Flat Washers, Spring Washers and Head Cap Bolts. (See Figure 2)

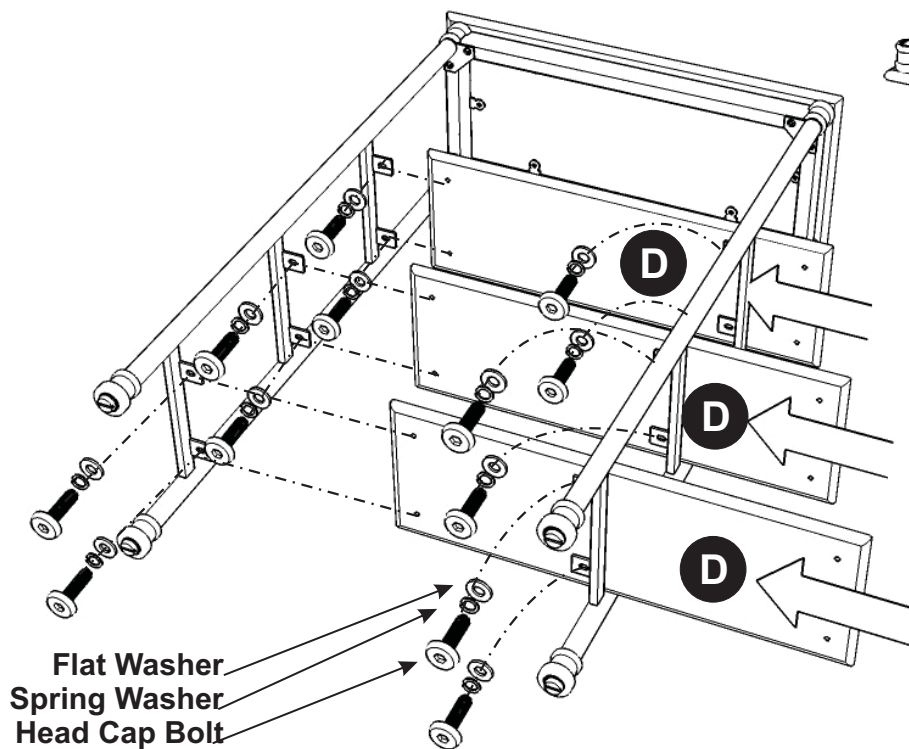

Flat Washer
Spring Washer
Head Cap Bolt

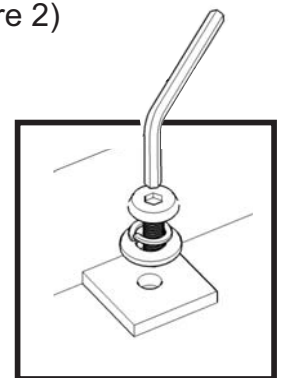

Figure 2

STEP 3

Turn the unit over to its' upright position. To level the unit, adjust the adjustable levelers on the bottom of unit. (See Figure 3)

Note: Unit must be level to work properly.

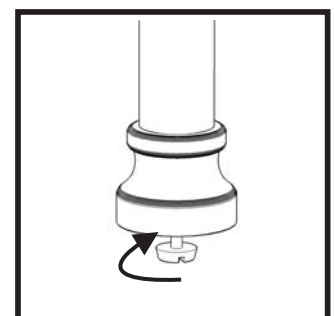

Figure 3