

ASSEMBLY INSTRUCTIONS

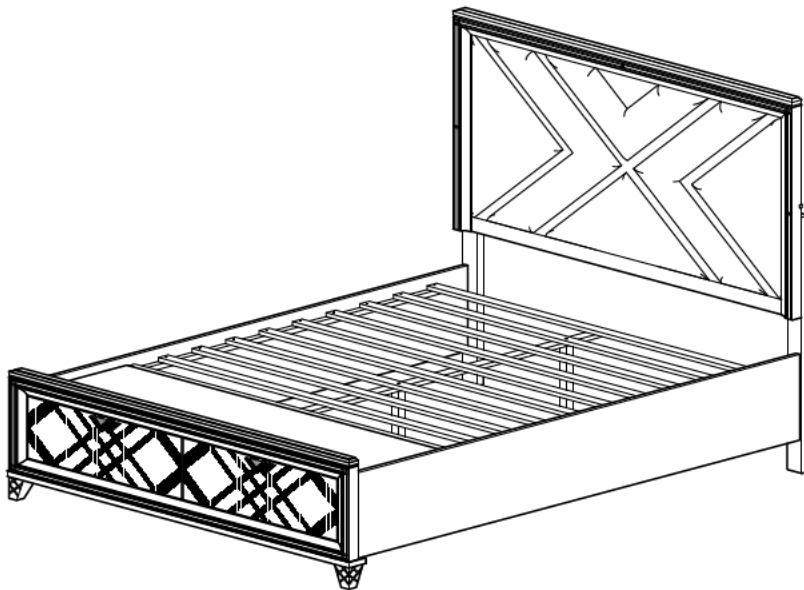

TOOLS REQUIRED

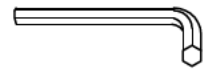

Allen Wrench

(Included)



**Phillips
Screwdriver**

(Not Included)



**3 - People
Recommended**

ASSEMBLY RATING



EASY —————> DIFFICULT

The Assembly Rating is a 5-point system showing the level of effort needed to assemble a specific product.

PRE ASSEMBLY INTRODUCTION

We understand building ready-to-assemble furniture can be a challenging experience for some. To help avoid confusion, we have provided some helpful tips that may speed up the process.



Teamwork

ALWAYS have at least two people to help with transporting and assembling the product to avoid potential injury and/or damage.



Suitable Location

Assembling near the area of the intended location is highly recommended.



Sufficient Space

Make sure you have enough space to move around during the assembly.



Avoid Scratches

Use cardboard, blankets or a carpeted area while assembling furniture to prevent scratches.



Flat Surface

Make sure the furniture rests on a flat and level surface with each leg evenly touching the floor.

ASSEMBLY AND CARE ADVICE



FAILURE TO FOLLOW THE GUIDELINES BELOW MAY RESULT IN INJURY AND/OR PROPERTY DAMAGE.



Position each part correctly and insert screws or bolts into their respective holes.

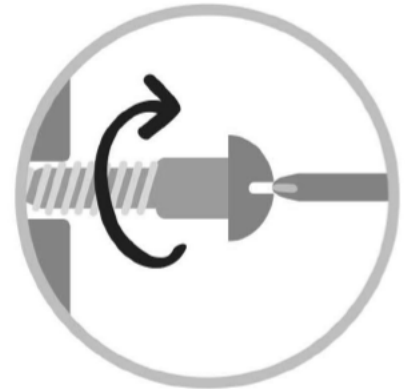

Turn clockwise to tighten and only tighten when step is completed or when instructed to do so.



Use the appropriate hand tools or power tools for assembly. Select steps, such as tightening screws and/or bolts, may require hand tools to avoid causing damage during assembly.



Save the instructions and store any supplied tools for later maintenance.



After two weeks, check and tighten any loose hardware and repeat again every six months thereafter.

IT IS THE USER'S RESPONSIBILITY TO MAINTAIN THE FURNITURE. THE HARDWARE MAY LOOSEN OVER TIME AND MAY CAUSE THE FURNITURE TO BE WOBBLY AND UNABLE TO SUPPORT ITS INTENDED WEIGHT CAPACITY. THIS MAY LEAD TO COLLAPSE AND MAY CAUSE SERIOUS INJURY.

QUEEN BED

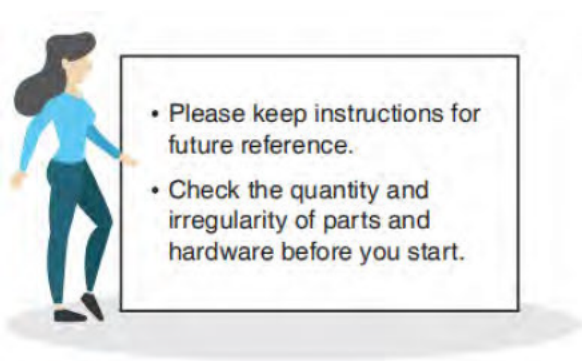

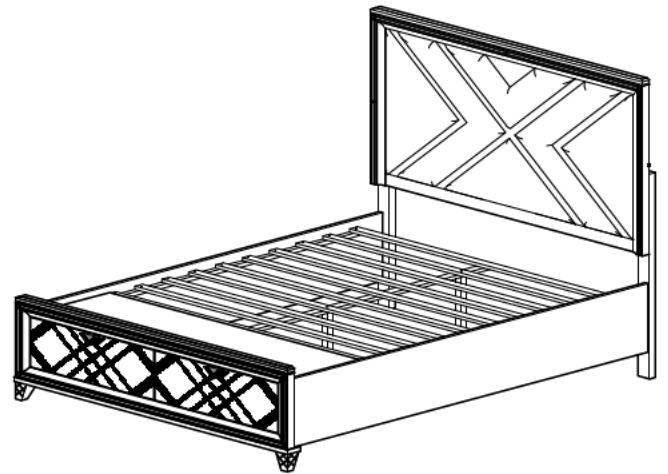

- Please keep instructions for future reference.
- Check the quantity and irregularity of parts and hardware before you start.





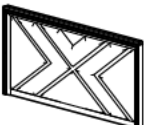

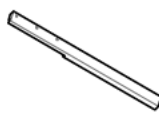

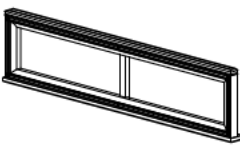

PARTS

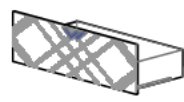
PART LIST OF HEADBOARD

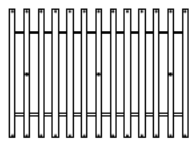
- | | | |
|--|--|--|
| <p>#1 1pc</p>  <p>Headboard</p> | <p>#2 1pc</p>  <p>Headboard Leg - (R)</p> | <p>#3 1pc</p>  <p>Headboard Leg - (L)</p> |
|--|--|--|

PART LIST OF FOOTBOARD

- | | | | | |
|--|---|--|--|---|
| <p>#4 1pc</p>  <p>Footboard</p> | <p>#5 2pcs</p>  <p>Acrylic Leg</p> | <p>#6 1pc</p>  <p>Drawer Support Rail</p> | <p>#7 2pcs</p>  <p>Drawer</p> | <p>#8 2pcs</p>  <p>Drawer Base Panel</p> |
| <p>#9 13pcs</p>  <p>Roll Slat</p> | <p>#10 3pcs</p>  <p>Slat Support Leg
440mm x 30mm x 30mm</p> | <p>#11 1pc</p>  <p>Drawer Support Leg</p> | <p>#12 1pc</p>  <p>Slat Cover Panel</p> | |

PART LIST OF SIDE RAIL

#13 2pcs



Side Rail

#14 1pc



Center Vertical Slat

HARDWARE

HARDWARE PACK IN HEADBOARD

#A 1pc



Allen Key

#B 6pcs



JCBC - M6 x 40mm

#C 6pcs



M6 Spring Washer

#D 6pcs



M6 Flat Washer

#E 1pc



AC Adapter

HARDWARE PACK IN FOOTBOARD

#F 1pc



Allen Key

#G 2pcs



JCBC - M6 x 16mm

#H 9pcs



JCBC - M6 x 35mm

#I 3pcs



JCBC - M6 x 60mm

#J 14pcs



M6 Spring Washer

#K 7pcs



M6 Flat Washer

#L 4pcs



1/4" Flat Washer

#M 26pcs



Screw 32mm

#N 2pcs











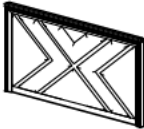

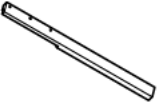



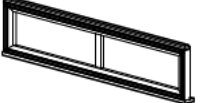







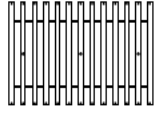

Screw 16mm

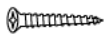
#O 4pcs

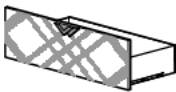
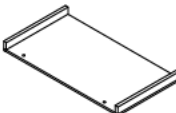

Adjustable Leveller

Designation		Part	Hardware
Headboard (1pc)	#1		 #A x 1pc  #B x 6pcs
Headboard Leg - (R) (1pc)	#2		 #C x 6pcs  #D x 6pcs
Headboard Leg - (L) (1pc)	#3		 #E x 1pc
Footboard (1pc)	#4		 #F x 1pc
Acrylic Leg (2pcs)	#5		 #G x 2pcs  #H x 9pcs  #I x 3pcs
Drawer Support Rail (1pc)	#6		 #J x 14pcs
Roll Slat (13pcs)	#9		 #K x 7pcs  #L x 4pcs
Slat Support Leg (3pcs)	#10		 #M x 26pcs
Drawer Support Leg (1pc)	#11		 #N x 2pcs  #O x 4pcs
Slat Cover Panel (1pc)	#12		
Side Rail (2pcs)	#13		
Center Vertical Slat (1pc)	#14		
Drawer (2pcs)	#7		
Drawer Base Panel (2pcs)	#8		

ASSEMBLY INSTRUCTIONS

1

Part #1 x 1pc

Part #2 x 1pc

Part #3 x 1pc

Hardware #A x 1pc

Hardware #B x 6pcs

Hardware #C x 6pcs

Hardware #D x 6pcs

Hardware #E x 1pc

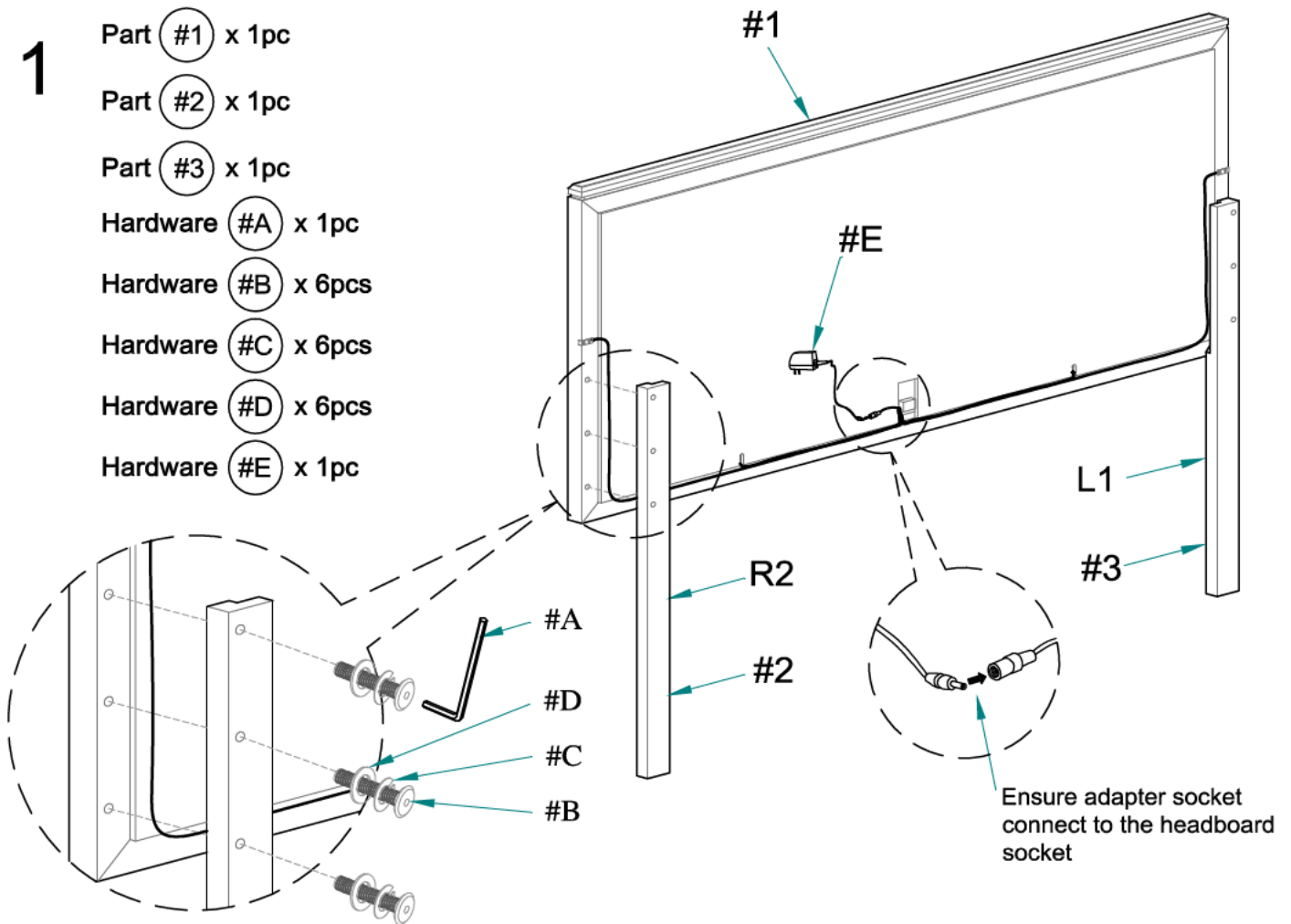

2

Part #1 x 1pc

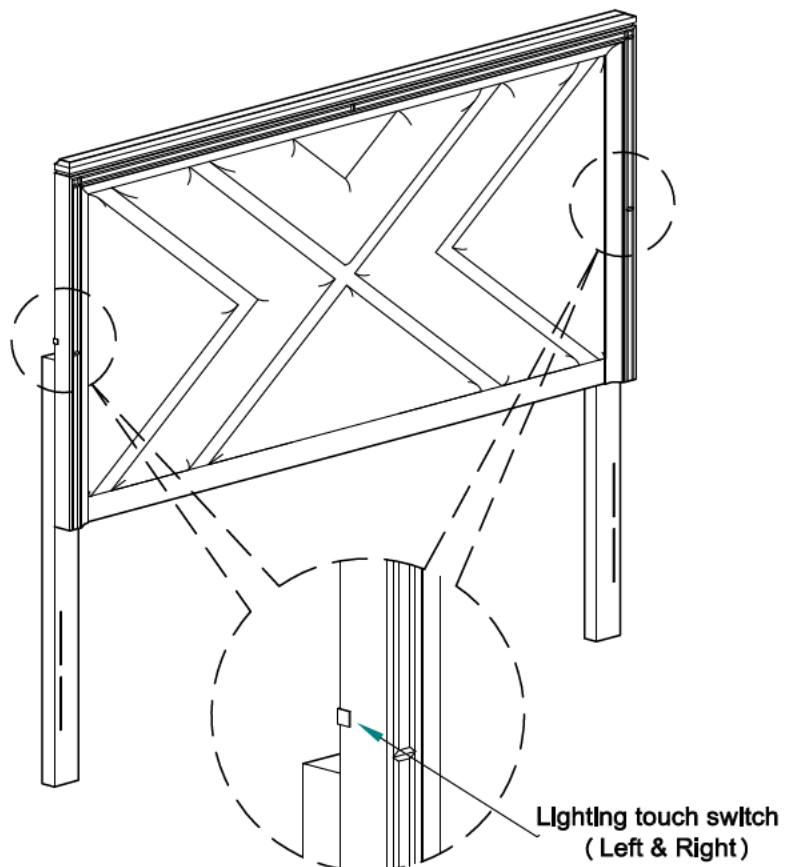

ASSEMBLY INSTRUCTIONS

3

Part #4 x 1pc

Part #5 x 2pcs

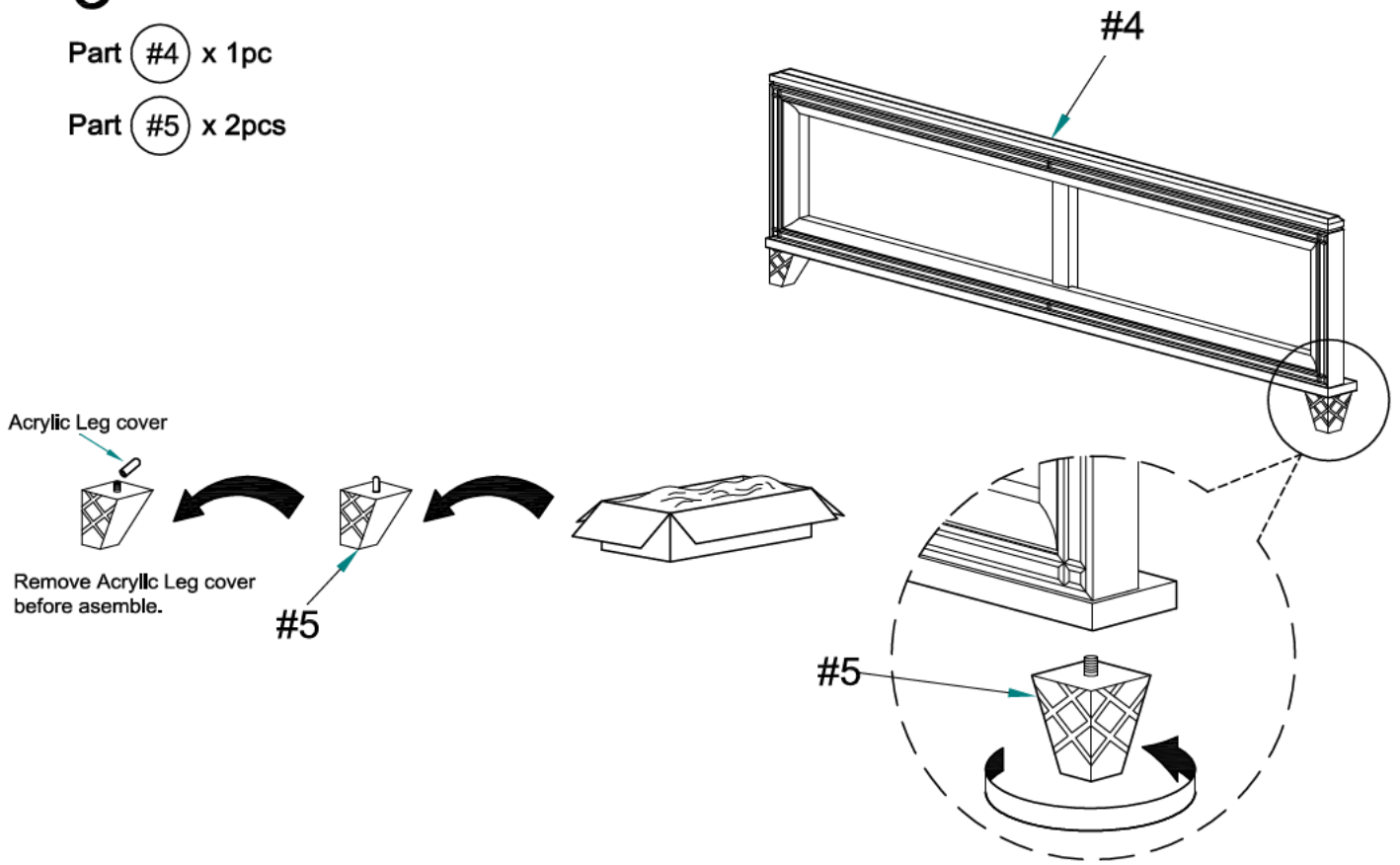

4

Part #1 x 1pc

Part #4 x 1pc

Part #13 x 2pcs

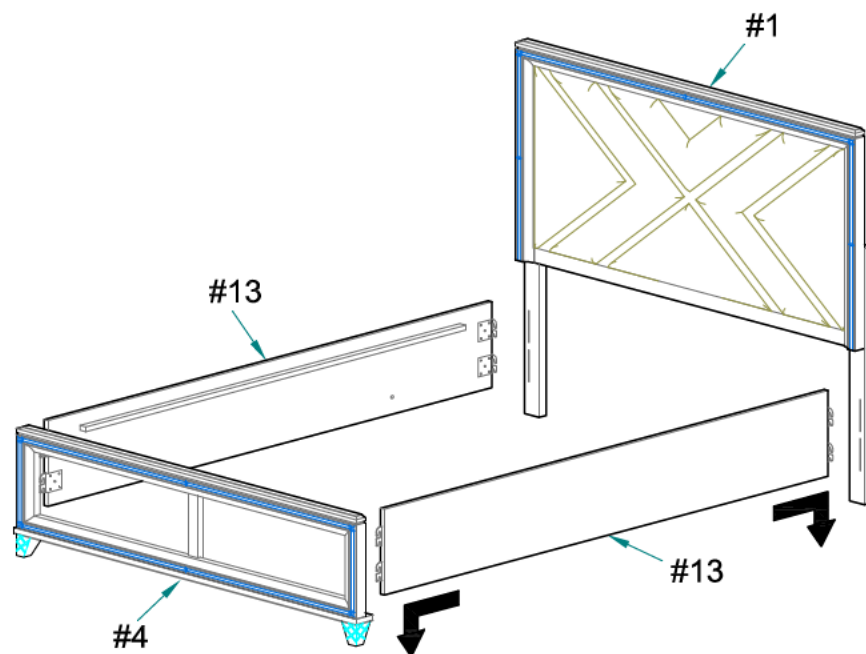

ASSEMBLY INSTRUCTIONS

5

Part #6 x 1pc

Hardware #F x 1pc

Hardware #G x 2pcs

Hardware #J x 2pcs

Hardware #K x 2pcs

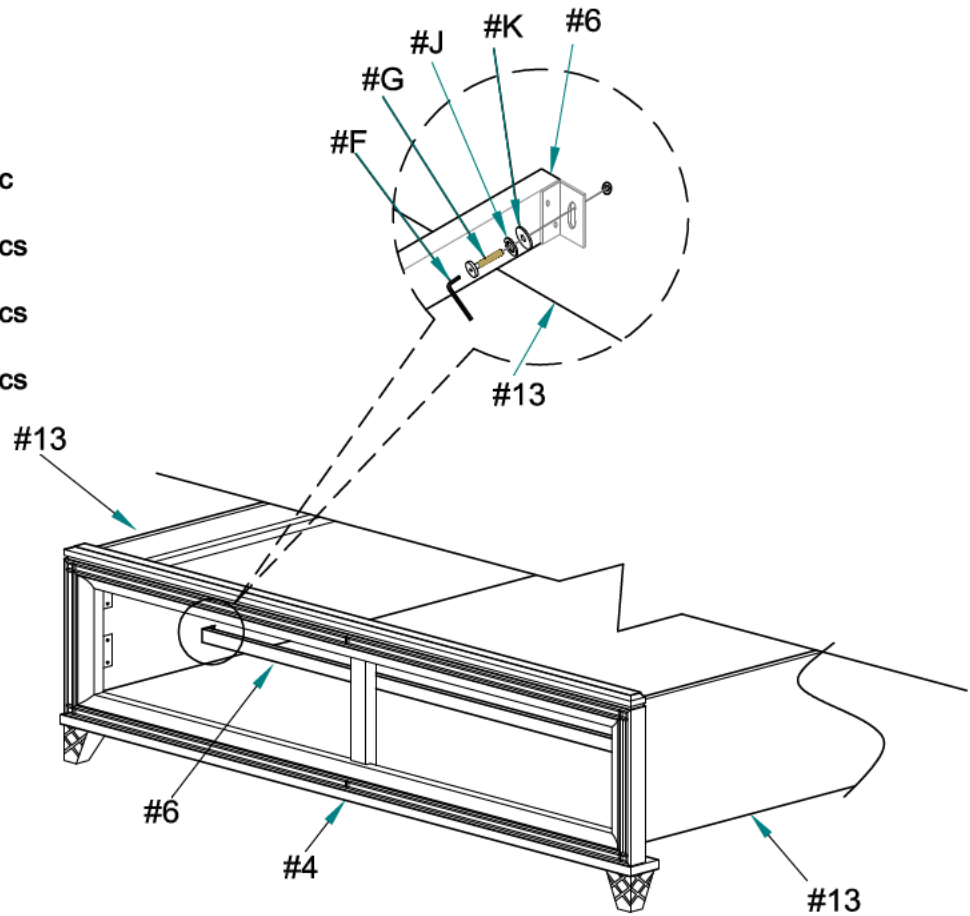

6

Make sure to fully extend rails to see the black switch on the rails.

Step to remove the drawer :

1. Pull the drawer
2. Using both hands,
 - Left hands side - pull up switch
 - Right hands side - pull down switch
3. Then remove the drawer from the drawer base panel

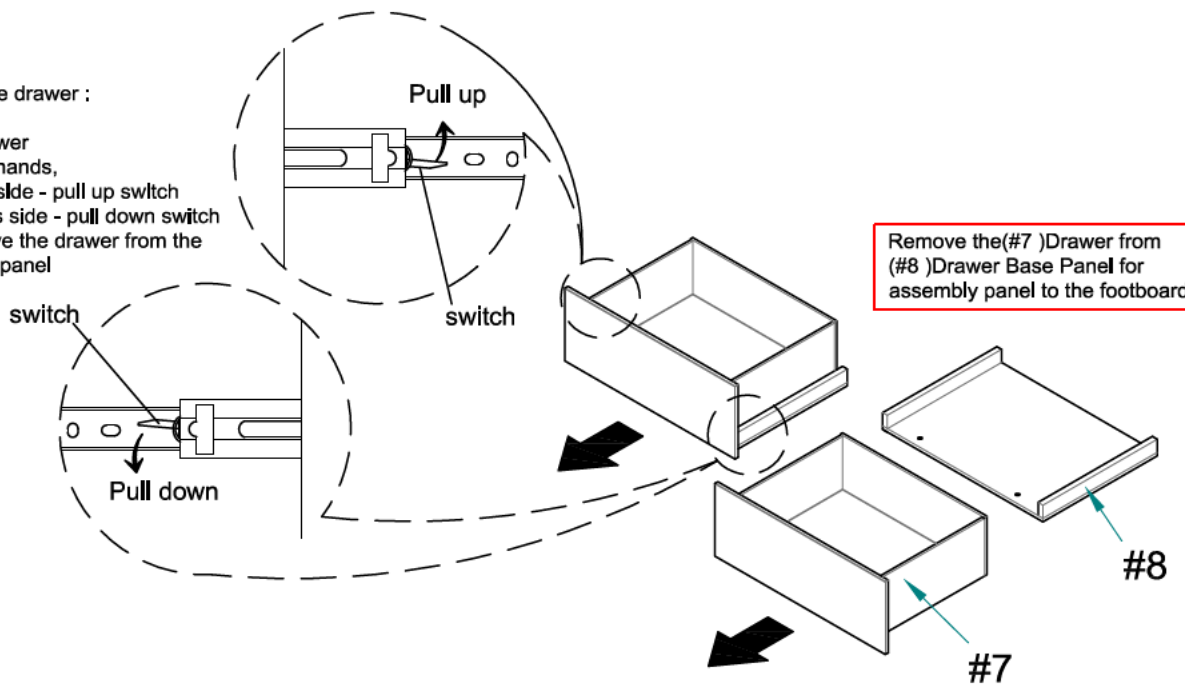

ASSEMBLY INSTRUCTIONS

7

- Part (#8) x 2pcs
- Hardware (#F) x 1pc
- Hardware (#H) x 8pcs
- Hardware (#J) x 8pcs
- Hardware (#K) x 4pcs
- Hardware (#L) x 4pcs

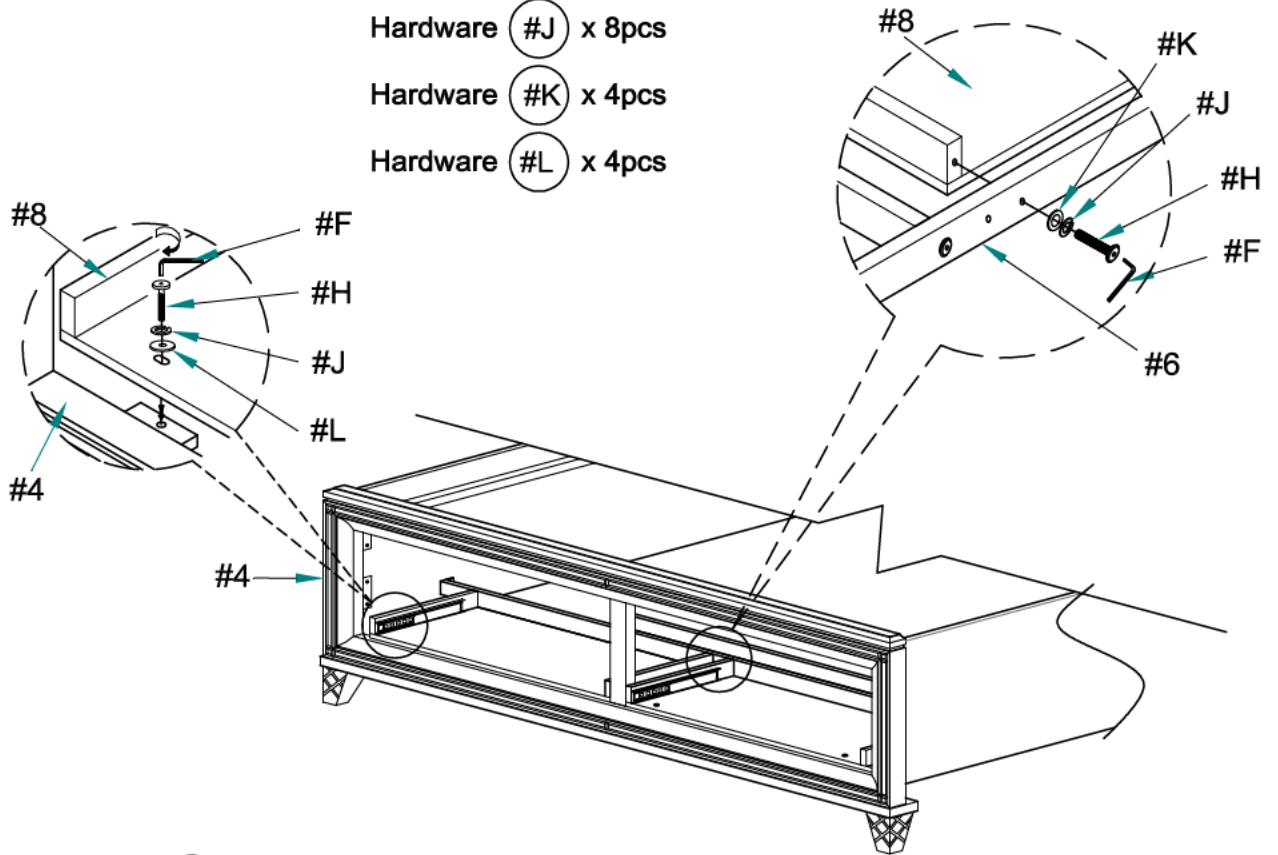

8

- Part (#11) x 1pc
- Hardware (#F) x 1pc
- Hardware (#H) x 1pc
- Hardware (#J) x 1pc
- Hardware (#K) x 1pc
- Hardware (#O) x 1pc

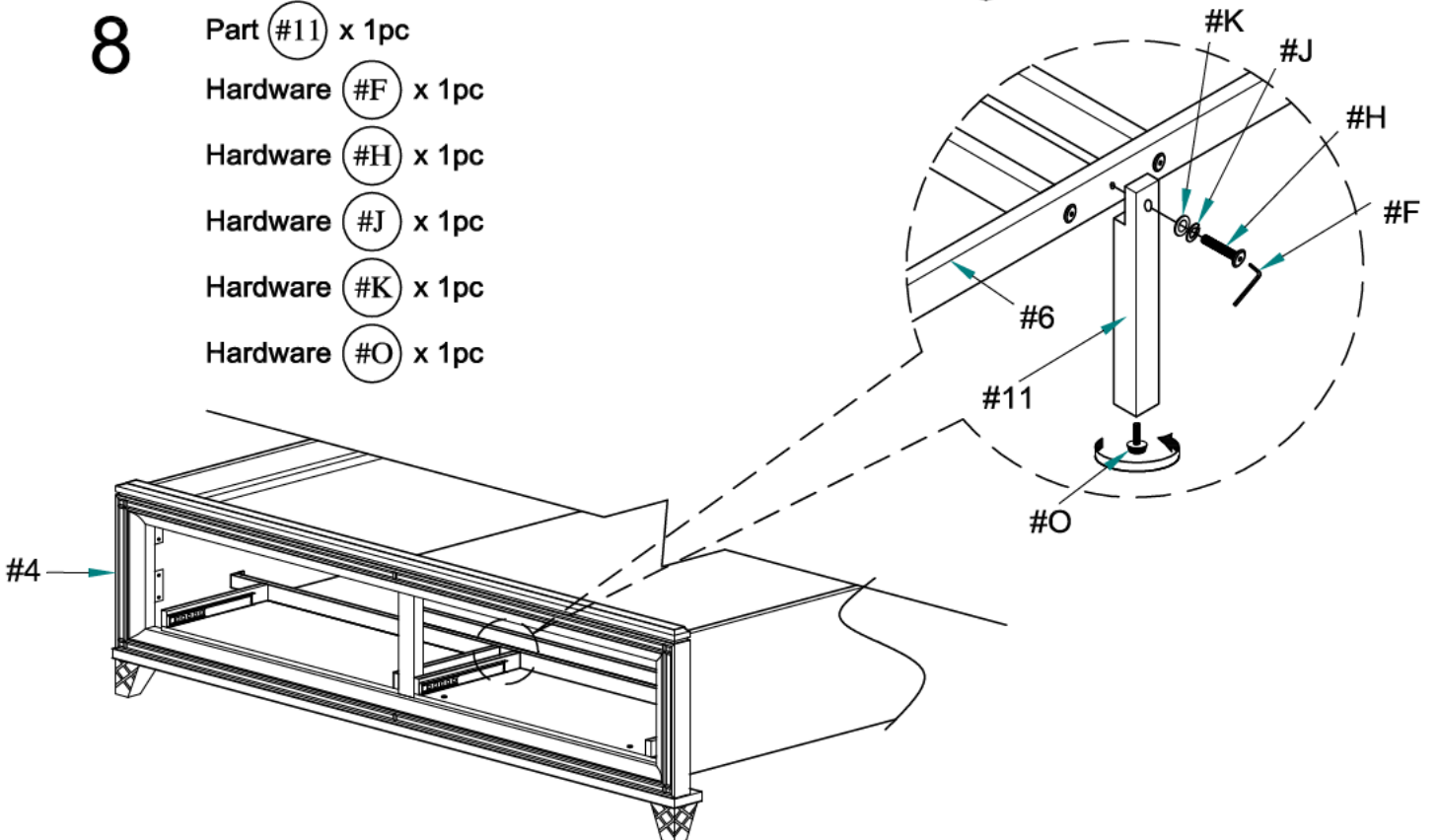

ASSEMBLY INSTRUCTIONS

9

Part **#7** x 2pcs

Step to Install the drawer on the drawer base panel :

***Prefer 2 person to Install the drawer

1. Adjust the ball bearing plate to the front as a diagram shows.
2. Then attach the drawer to the drawer base panel and install with carefully.

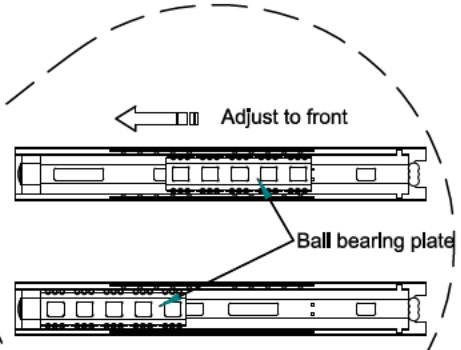

Insert the drawer (**#7**) to the footboard (**#4**)

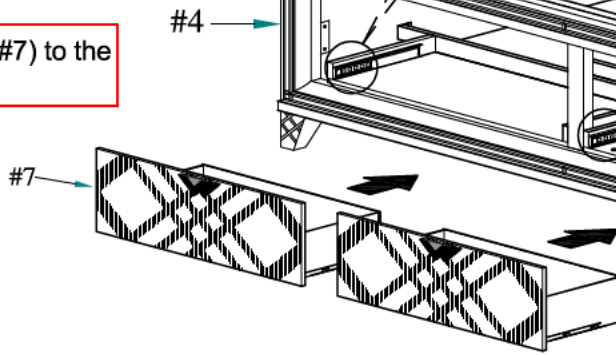

Align and connect the rails of the drawer base to the drawers.

10

Part **#9** x 13pcs Hardware **#F** x 1pc

Part **#10** x 3pcs Hardware **#I** x 3pcs

Part **#12** x 1pc Hardware **#J** x 3pcs

Part **#14** x 1pc Hardware **#M** x 26pcs

Hardware **#O** x 3pcs

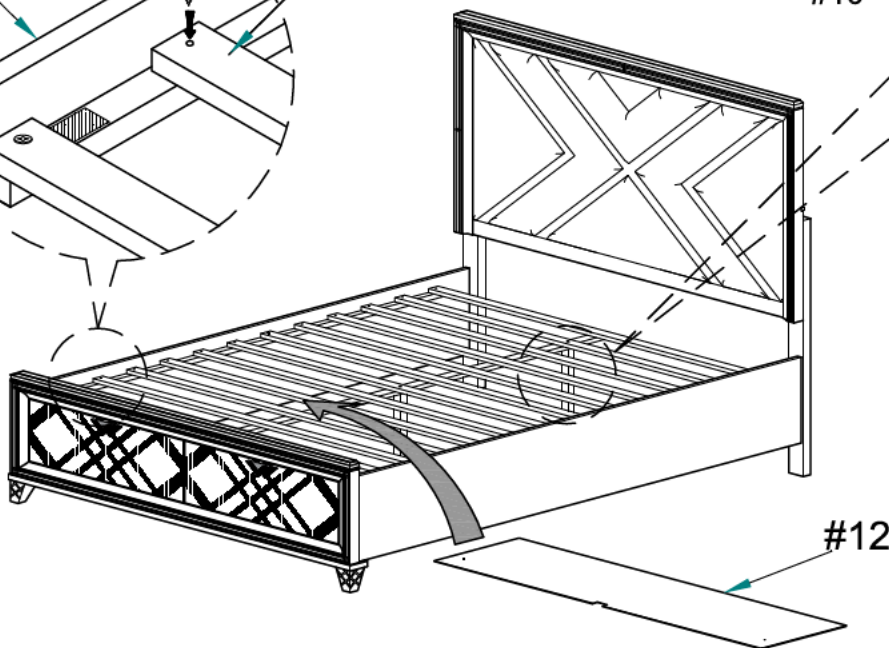
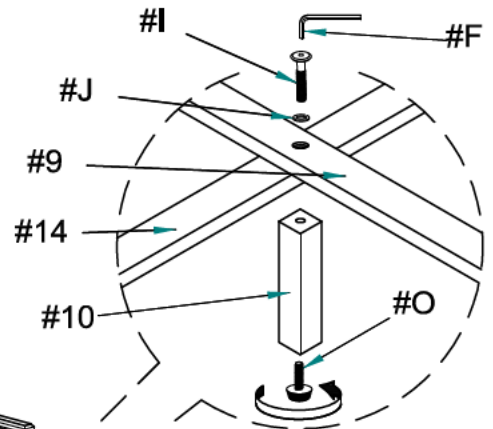
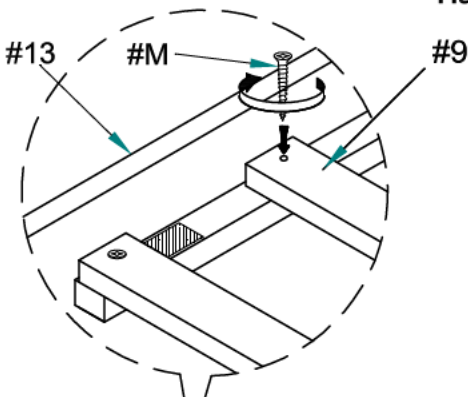

ASSEMBLY INSTRUCTIONS

11 Hardware  x 2pcs

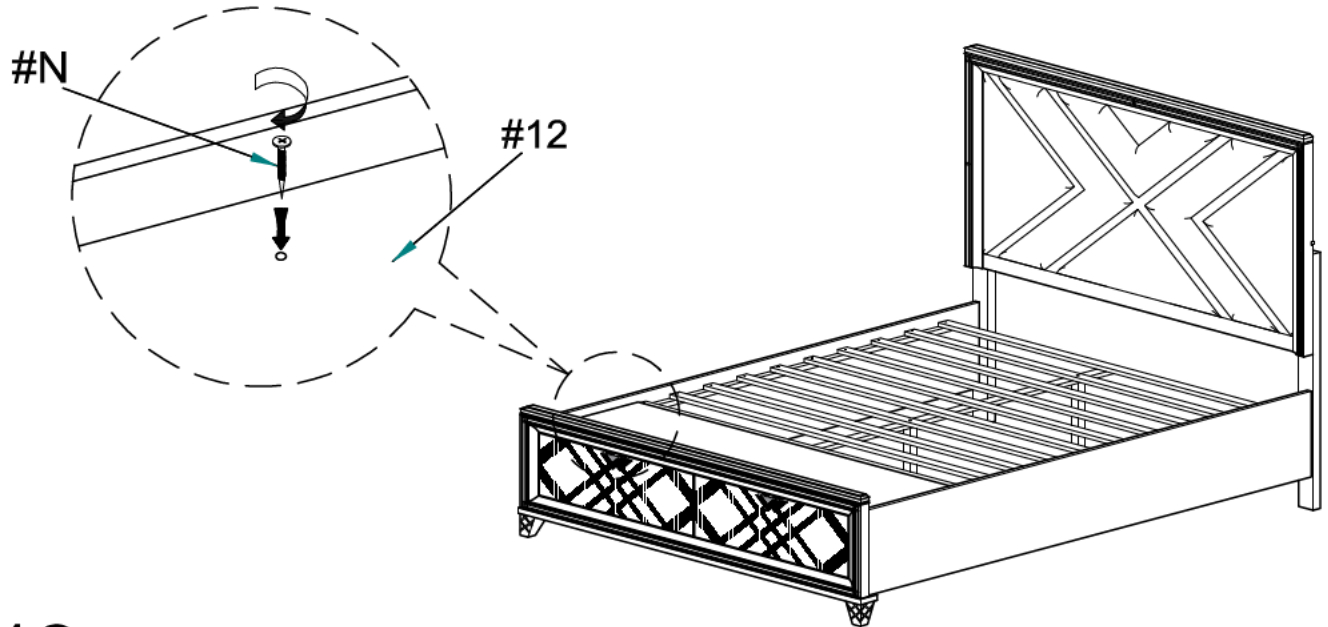

12

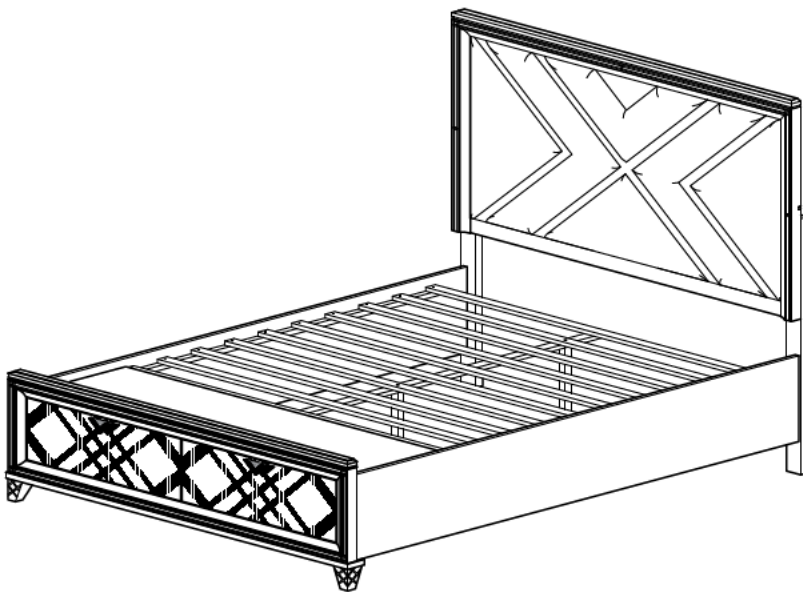

ASSEMBLY COMPLETED



Please ensure the furniture rests on an even and flat surface. If the product wobbles or feels loose, double-check all bolts and/or screws are properly tightened and secured.



Keep this handy!

Please retain this instruction manual and any order-related information for future reference.



Lift, don't drag!

To avoid damage to product please always LIFT the product when transporting or adjusting the placement.

ASSEMBLY INSTRUCTIONS

TOOLS REQUIRED

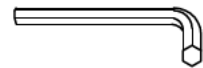

Allen Wrench

(Included)



**Phillips
Screwdriver**

(Not Included)



**3 - People
Recommended**

ASSEMBLY RATING



EASY —————> DIFFICULT

The Assembly Rating is a 5-point system showing the level of effort needed to assemble a specific product.

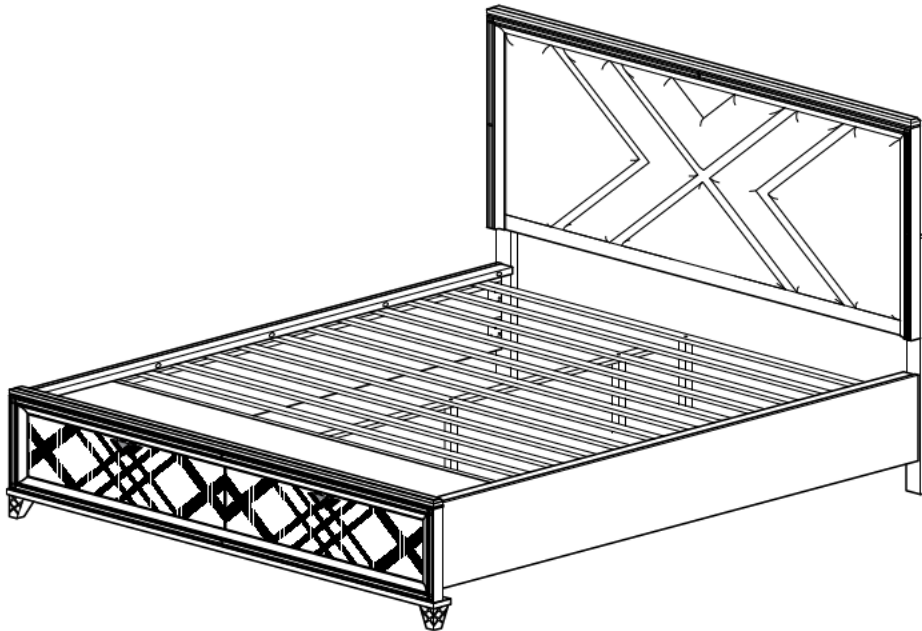

PRE ASSEMBLY INTRODUCTION

We understand building ready-to-assemble furniture can be a challenging experience for some. To help avoid confusion, we have provided some helpful tips that may speed up the process.



Teamwork

ALWAYS have at least two people to help with transporting and assembling the product to avoid potential injury and/or damage.



Suitable Location

Assembling near the area of the intended location is highly recommended.



Sufficient Space

Make sure you have enough space to move around during the assembly.



Avoid Scratches

Use cardboard, blankets or a carpeted area while assembling furniture to prevent scratches.



Flat Surface

Make sure the furniture rests on a flat and level surface with each leg evenly touching the floor.

ASSEMBLY AND CARE ADVICE



FAILURE TO FOLLOW THE GUIDELINES BELOW MAY RESULT IN INJURY AND/OR PROPERTY DAMAGE.



Position each part correctly and insert screws or bolts into their respective holes.

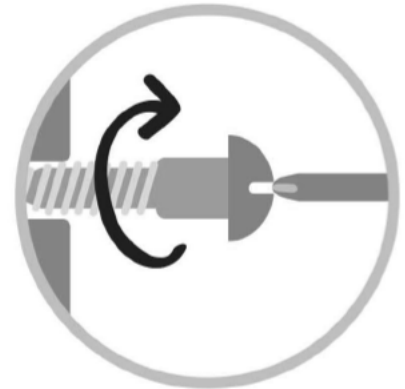

Turn clockwise to tighten and only tighten when step is completed or when instructed to do so.



Use the appropriate hand tools or power tools for assembly. Select steps, such as tightening screws and/or bolts, may require hand tools to avoid causing damage during assembly.



Save the instructions and store any supplied tools for later maintenance.



After two weeks, check and tighten any loose hardware and repeat again every six months thereafter.

IT IS THE USER'S RESPONSIBILITY TO MAINTAIN THE FURNITURE. THE HARDWARE MAY LOOSEN OVER TIME AND MAY CAUSE THE FURNITURE TO BE WOBBLY AND UNABLE TO SUPPORT ITS INTENDED WEIGHT CAPACITY. THIS MAY LEAD TO COLLAPSE AND MAY CAUSE SERIOUS INJURY.

CAL KING BED



- Please keep instructions for future reference.
- Check the quantity and irregularity of parts and hardware before you start.

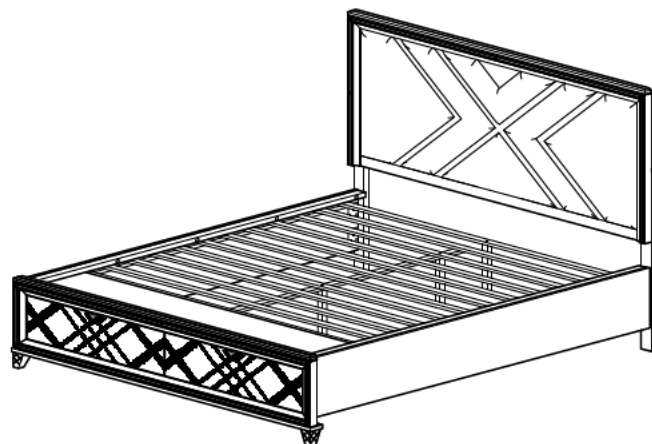

PARTS

PART LIST OF HEADBOARD

#1 1pc

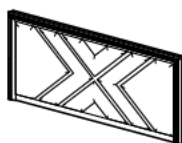

Headboard

#2 1pc



Headboard Leg - (R)

#3 1pc



Headboard Leg - (L)

PART LIST OF FOOTBOARD

#4 1pc

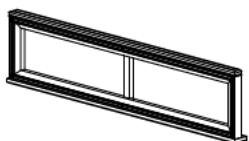

Footboard

#5 2pcs



Acrylic Leg

#6 1pc



Drawer Support Rail

#7 2pcs

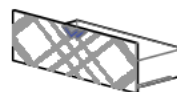

Drawer

#8 2pcs

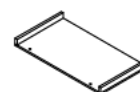

Drawer Base Panel

#9 13pcs

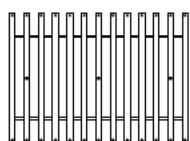

Roll Slat

#10 3pcs



Slat Support Leg
440mm x 30mm x 30mm

#11 1pc





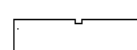

Drawer Support Leg

#12 1pc



Slat Cover Panel

PART LIST OF SIDE RAIL











#13 2pcs	#14 1pc	#15 2pcs	#16 1pc	#17 1pc
				
Side Rail	Center Vertical Slat	Top Cap	Slat	Slat Support (long) 455mm x 30mm x 30mm

HARDWARE







HARDWARE PACK IN HEADBOARD











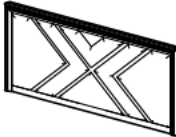





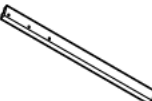

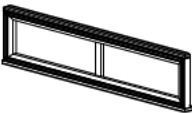





#A 1pc	#B 6pcs	#C 6pcs	#D 6pcs	#E 1pc
				
Allen Key	JCBC - M6 x 40mm	M6 Spring Washer	M6 Flat Washer	AC Adapter

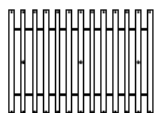



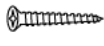



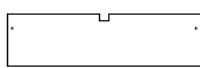

HARDWARE PACK IN FOOTBOARD

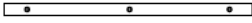
#F 1pc	#G 2pcs	#H 9pcs	#I 3pcs	#J 14pcs
				
Allen Key	JCBC - M6 x 16mm	JCBC - M6 x 35mm	JCBC - M6 x 60mm	M6 Spring Washer
#K 7pcs	#L 4pcs	#M 26pcs	#N 2pcs	#O 4pcs
				
M6 Flat Washer	1/4" Flat Washer	Screw 32mm	Screw 16mm	Adjustable Leveller

HARDWARE PACK IN SIDE RAIL

#P 1pc	#Q 1pc	#R 10pcs	#S 11pcs	#T 10pcs
				
Allen Key	JCBC - M6 x 35mm	JCBC - M6 x 45mm	M6 Spring Washer	M6 Spring Washer
#U 2pcs	#V 1pc			
				
Screw 32mm	Adjustable Leveller			

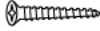
Designation		Part	Hardware
Headboard (1pc)	#1		 #A x 1pc  #B x 6pcs
Headboard Leg - (R) (1pc)	#2		 #C x 6pcs  #D x 6pcs
Headboard Leg - (L) (1pc)	#3		 #E x 1pc
Footboard (1pc)	#4		 #F x 1pc  #G x 2pcs
Acrylic Leg (2pcs)	#5		 #H x 9pcs  #I x 3pcs
Drawer Support Rail (1pc)	#6		 #J x 14pcs
Roll Slat (13pcs)	#9		 #K x 7pcs  #L x 4pcs
Slat Support Leg (3pcs)	#10		 #M x 26pcs
Drawer Support Leg (1pc)	#11		 #N x 2pcs  #O x 4pcs
Slat Cover Panel (1pc)	#12		

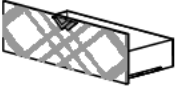
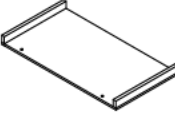
Designation	Part		Hardware
Side Rail (2pcs)	#13		 #P x 1pc
Center Vertical Slat (1pc)	#14		 #Q x 1pc  #R x 10pcs
Top Cap (2pcs)	#15		 #S x 11pcs  #T x 10pcs
Slat (1pc)	#16		 #U x 2pcs
Slat Support Leg (1pc)	#17		 #Y x 1pcs
Drawer (2pcs)	#7		
Drawer Base Panel (2pcs)	#8		

ASSEMBLY INSTRUCTIONS

1

Part #1 x 1pc

Part #2 x 1pc

Part #3 x 1pc

Hardware #A x 1pc

Hardware #B x 6pcs

Hardware #C x 6pcs

Hardware #D x 6pcs

Hardware #E x 1pc

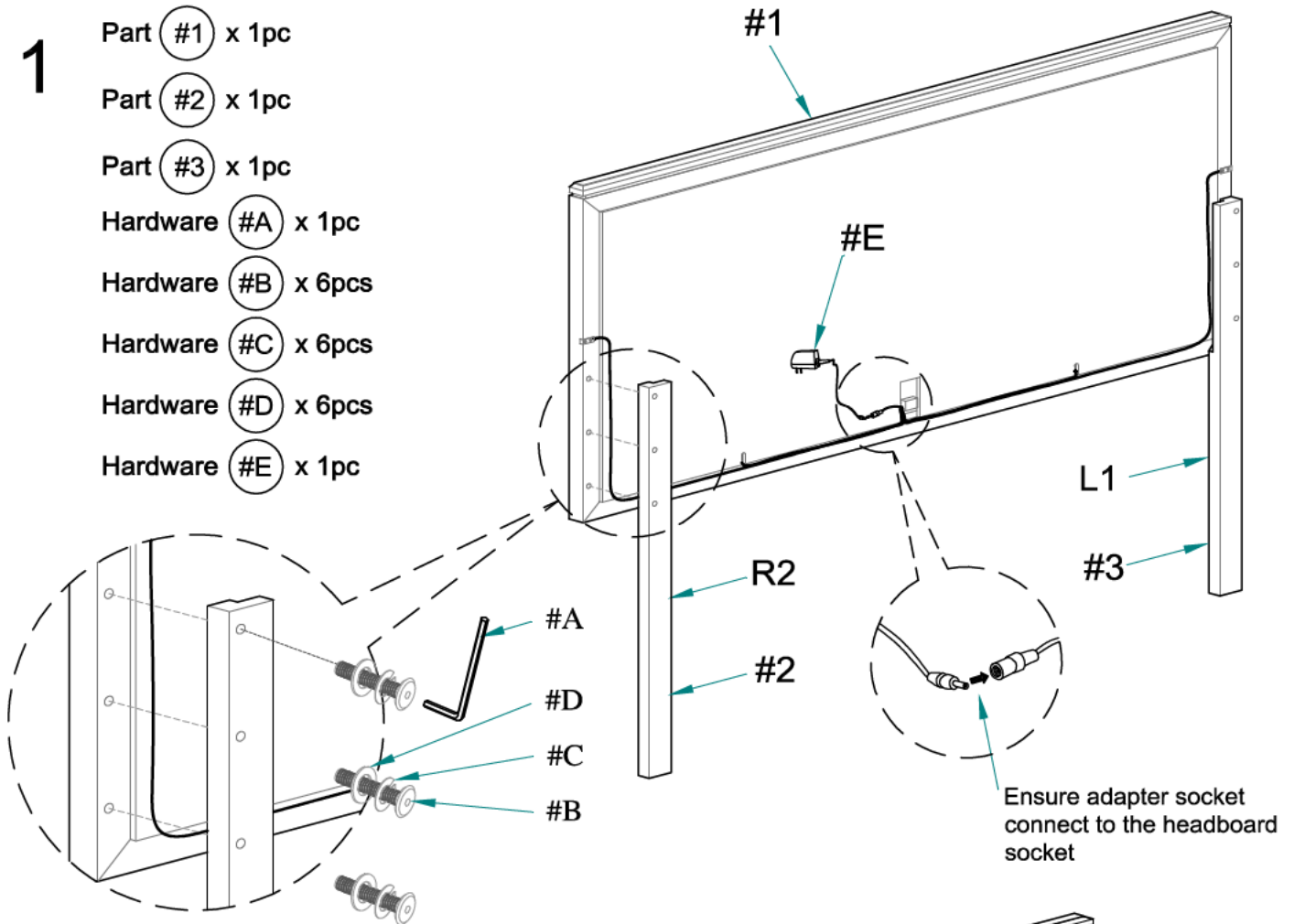

2

Part #1 x 1pc

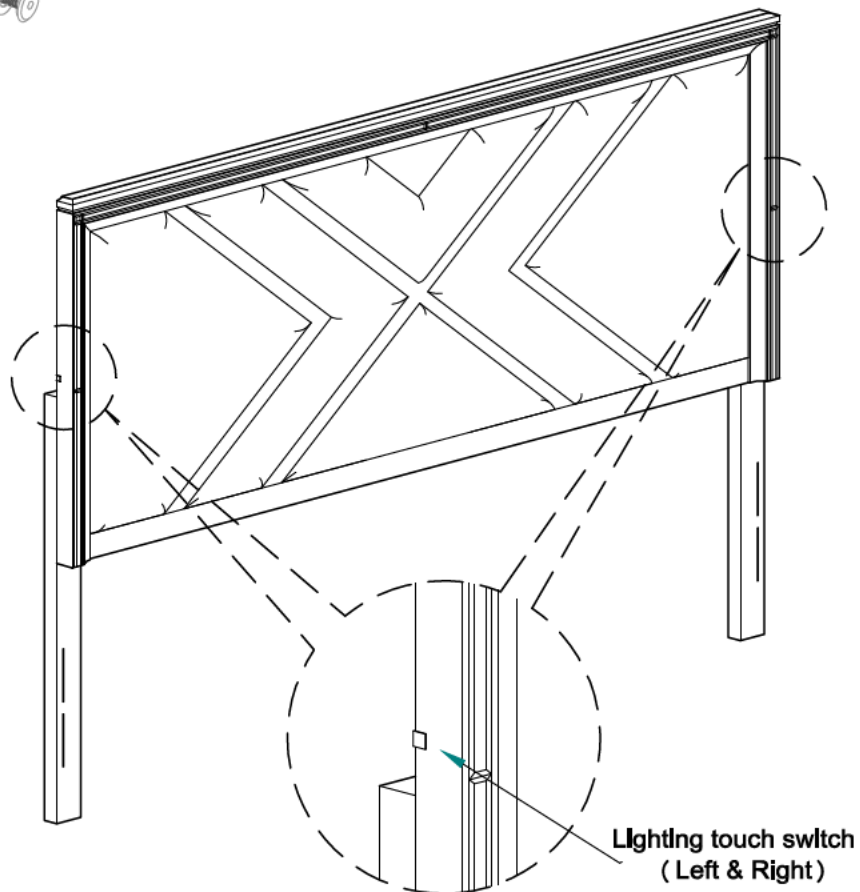

ASSEMBLY INSTRUCTIONS

3

Part #4 x 1pc

Part #5 x 2pcs

Acrylic Leg cover

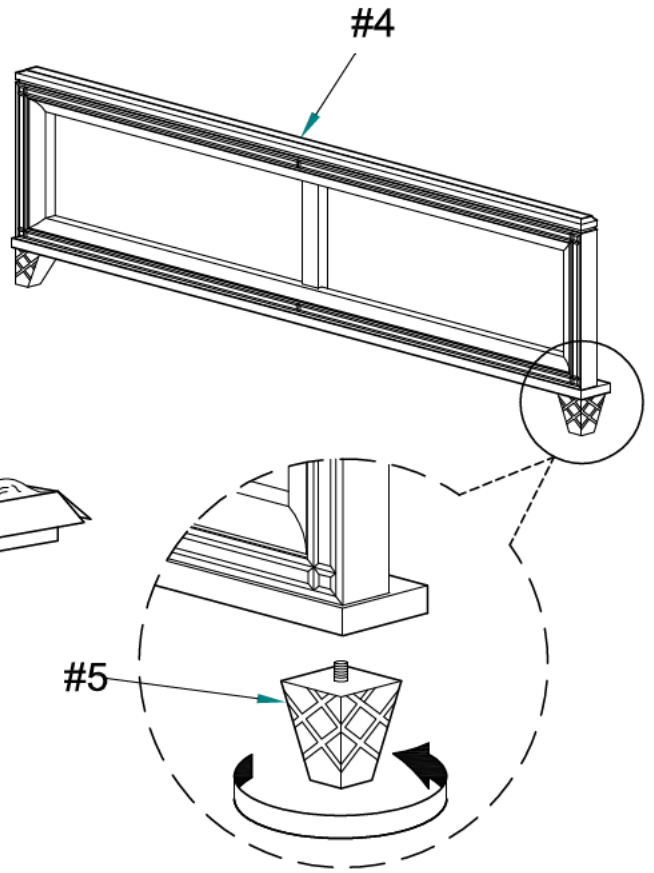
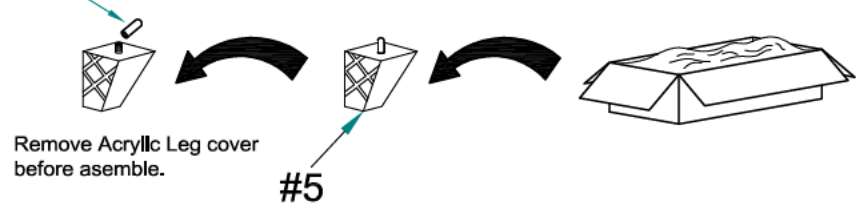

4

Part #1 x 1pc

Part #4 x 1pc

Part #13 x 2pcs

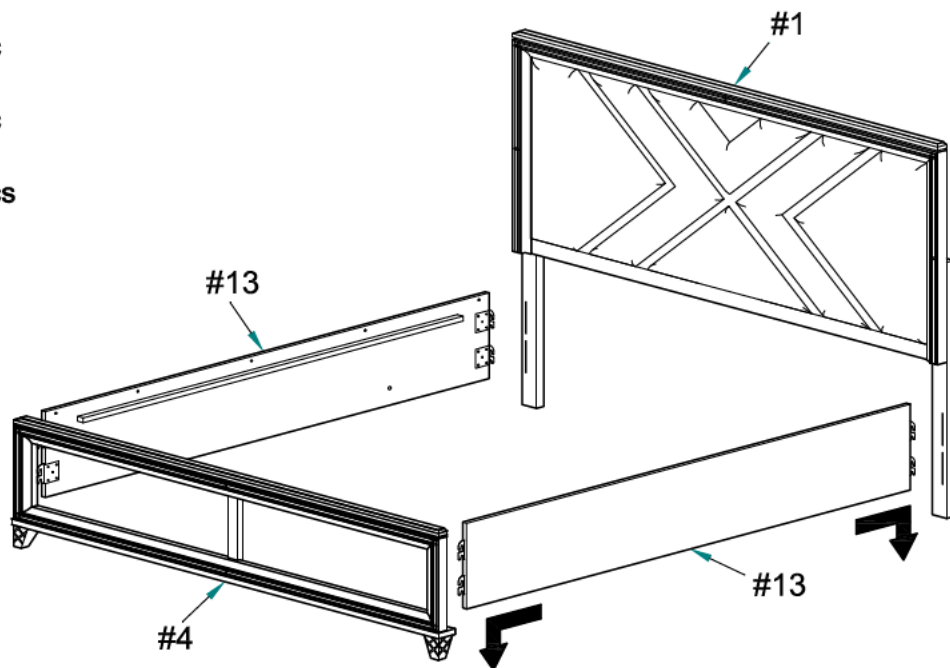

ASSEMBLY INSTRUCTIONS

5

Part #6 x 1pc

Hardware #F x 1pc

Hardware #G x 2pcs

Hardware #J x 2pcs

Hardware #K x 2pcs

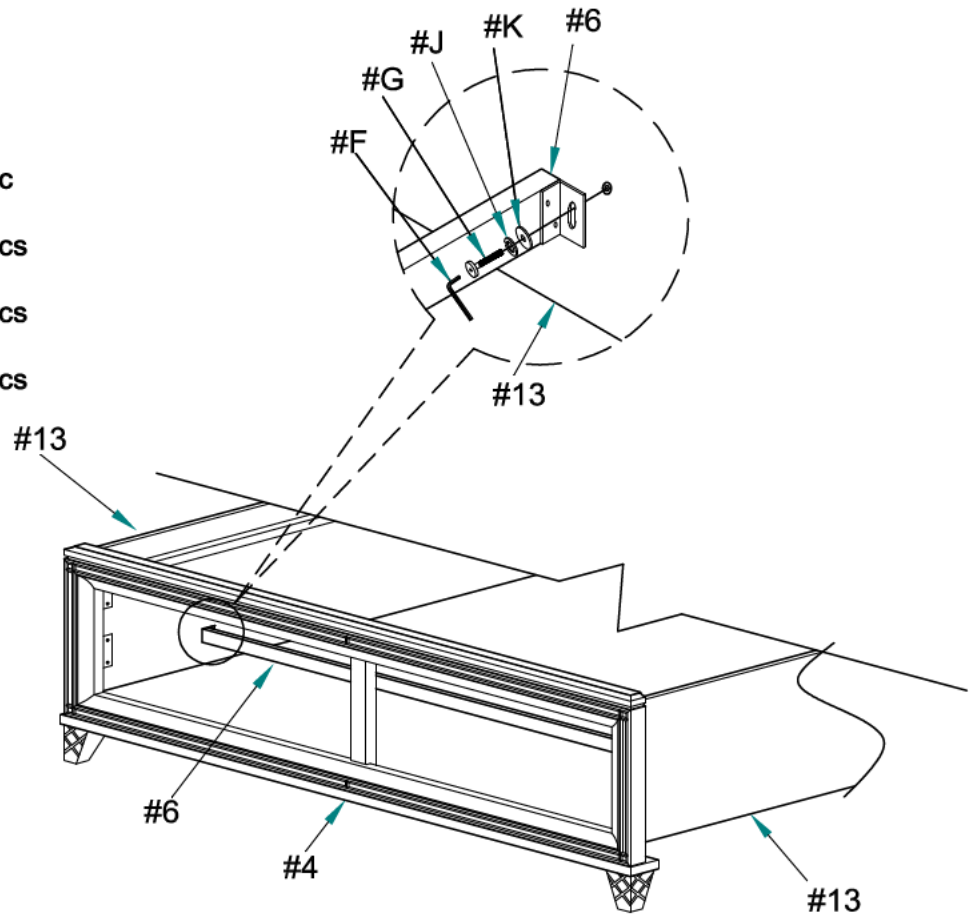

6

Make sure to fully extend rails to see the black switch on the rails.

Step to remove the drawer :

1. Pull the drawer
2. Using both hands,
 - Left hands side - pull up switch
 - Right hands side - pull down switch
3. Then remove the drawer from the drawer base panel

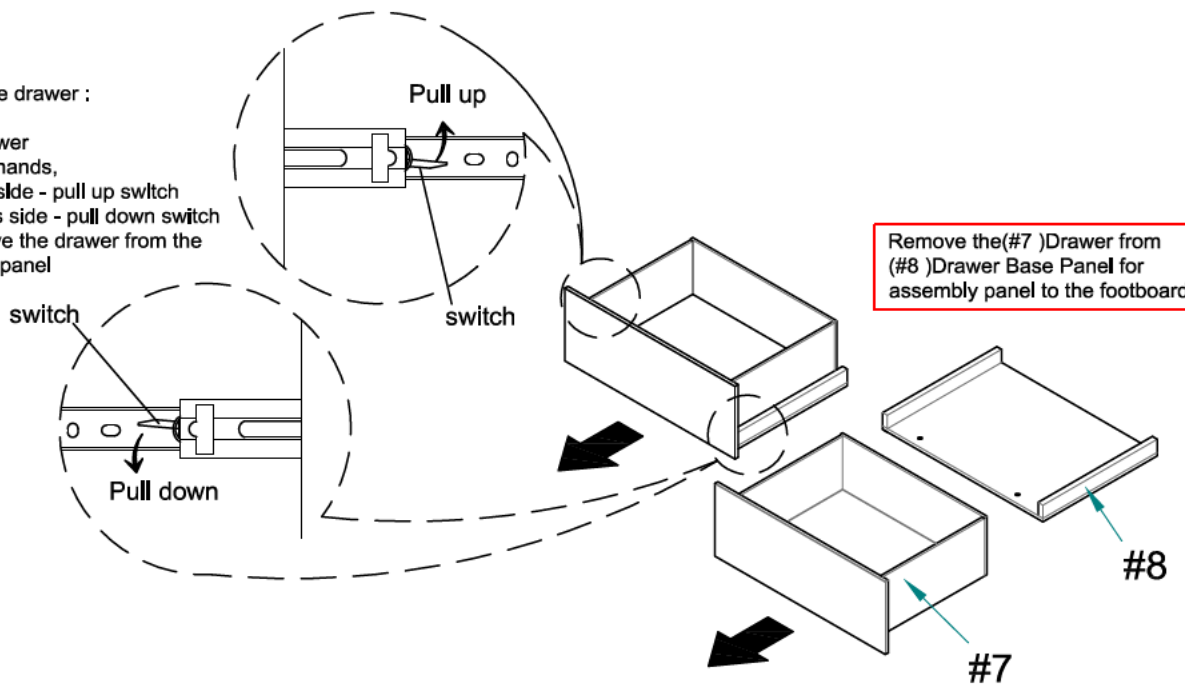

ASSEMBLY INSTRUCTIONS

7

- Part (#8) x 2pcs
- Hardware (#F) x 1pc
- Hardware (#H) x 8pcs
- Hardware (#J) x 8pcs
- Hardware (#K) x 4pcs
- Hardware (#L) x 4pcs

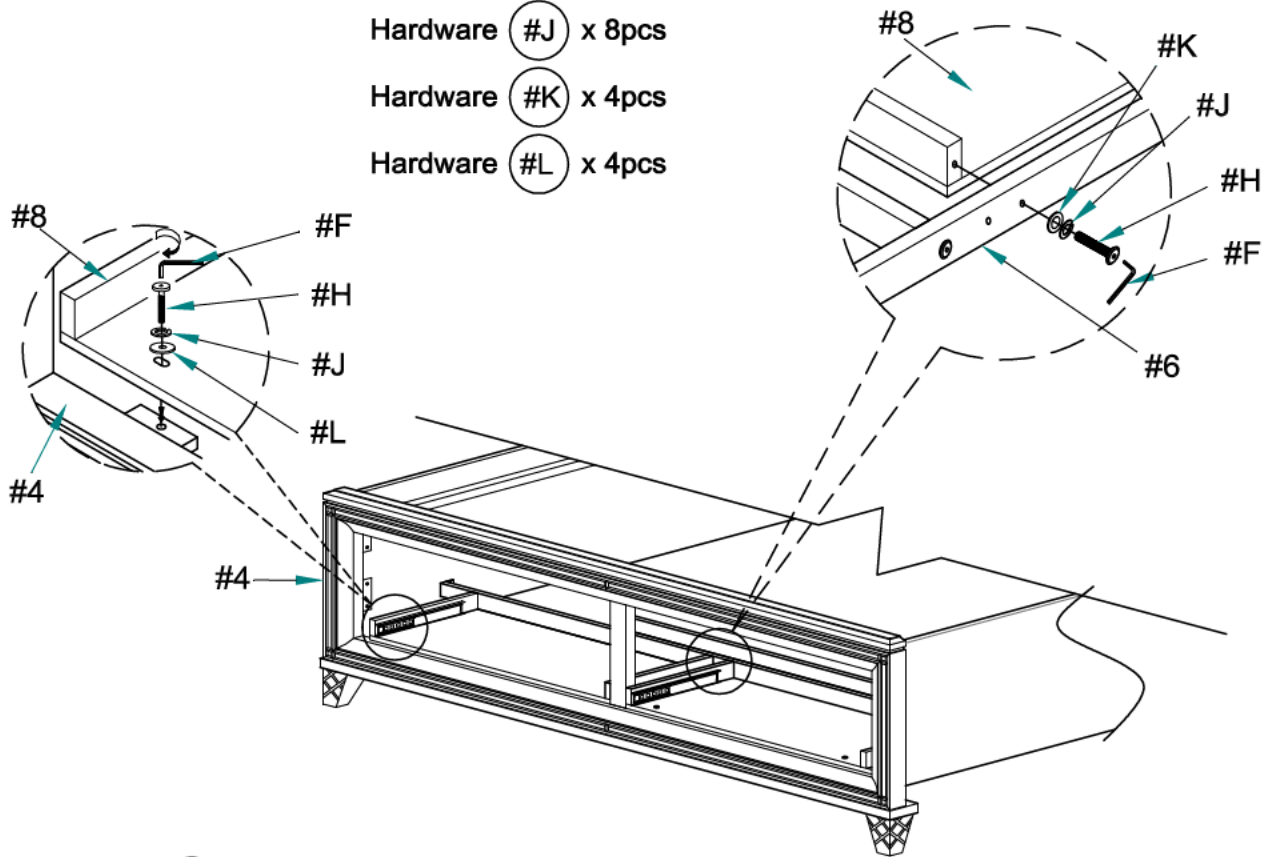

8

- Part (#11) x 1pc
- Hardware (#F) x 1pc
- Hardware (#H) x 1pc
- Hardware (#J) x 1pc
- Hardware (#K) x 1pc
- Hardware (#O) x 1pc

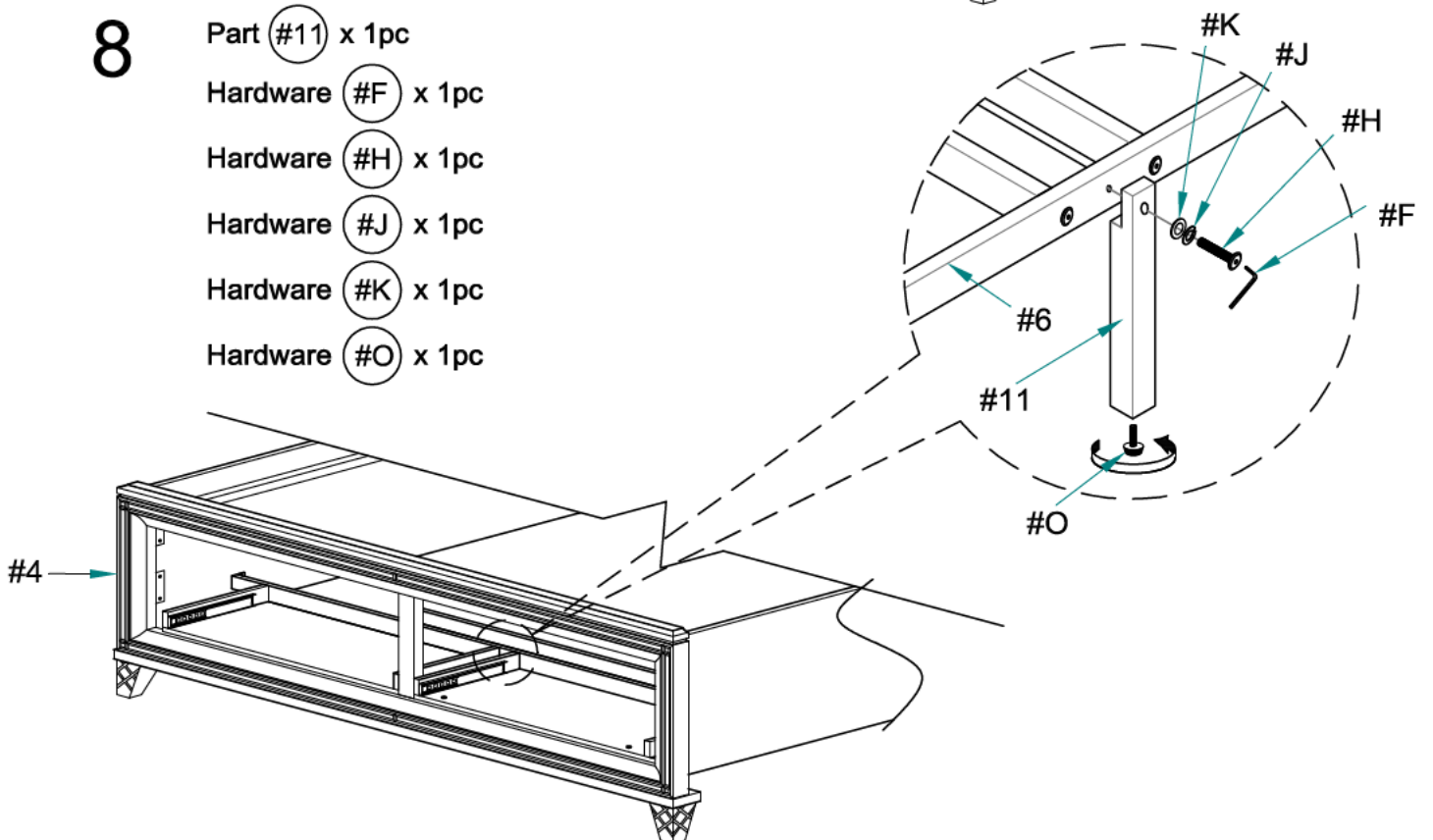

ASSEMBLY INSTRUCTIONS

9

Part #7 x 2pcs

Step to install the drawer on the drawer base panel :

***Prefer 2 person to install the drawer

1. Adjust the ball bearing plate to the front as a diagram shows.
2. Then attach the drawer to the drawer base panel and install with carefully.

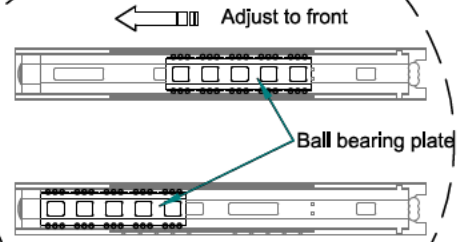

Insert the drawer (#7) to the footboard (#4)

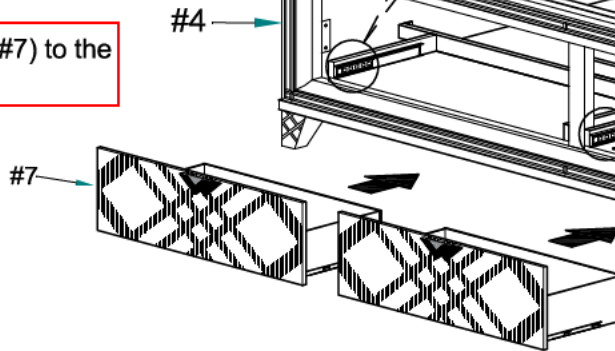

Align and connect the rails of the drawer base to the drawers.

10

Part #9 x 13pcs Hardware #F x 1pc

Part #10 x 3pcs Hardware #I x 3pcs

Part #14 x 1pc Hardware #J x 3pcs

Hardware #M x 26pcs

Hardware #O x 3pcs

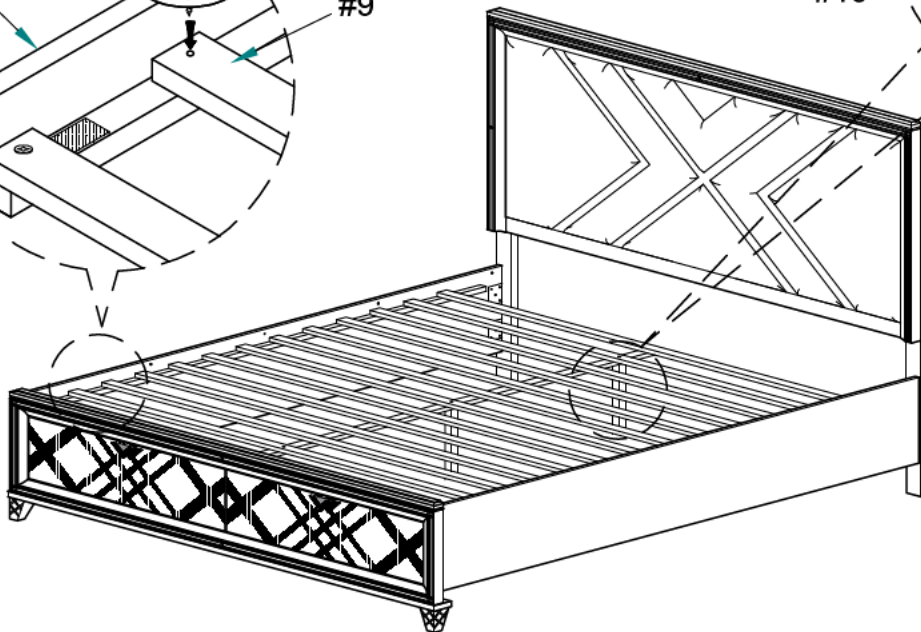
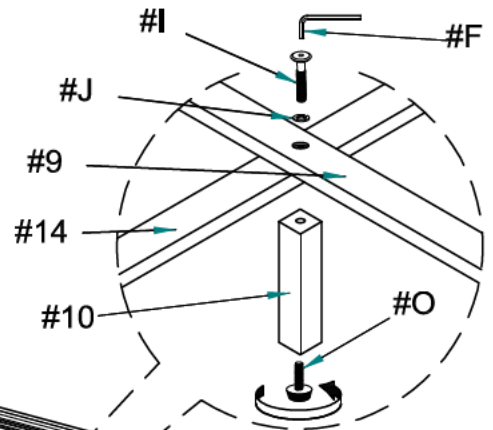
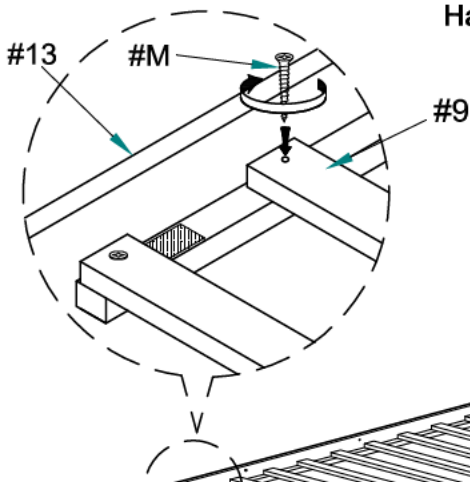

ASSEMBLY INSTRUCTIONS

11

Part #12 x 1pc

Hardware #P x 1pc

Part #16 x 1pc

Hardware #Q x 1pc

Part #17 x 1pc

Hardware #S x 1pc

Hardware #U x 2pcs

Hardware #V x 1pc

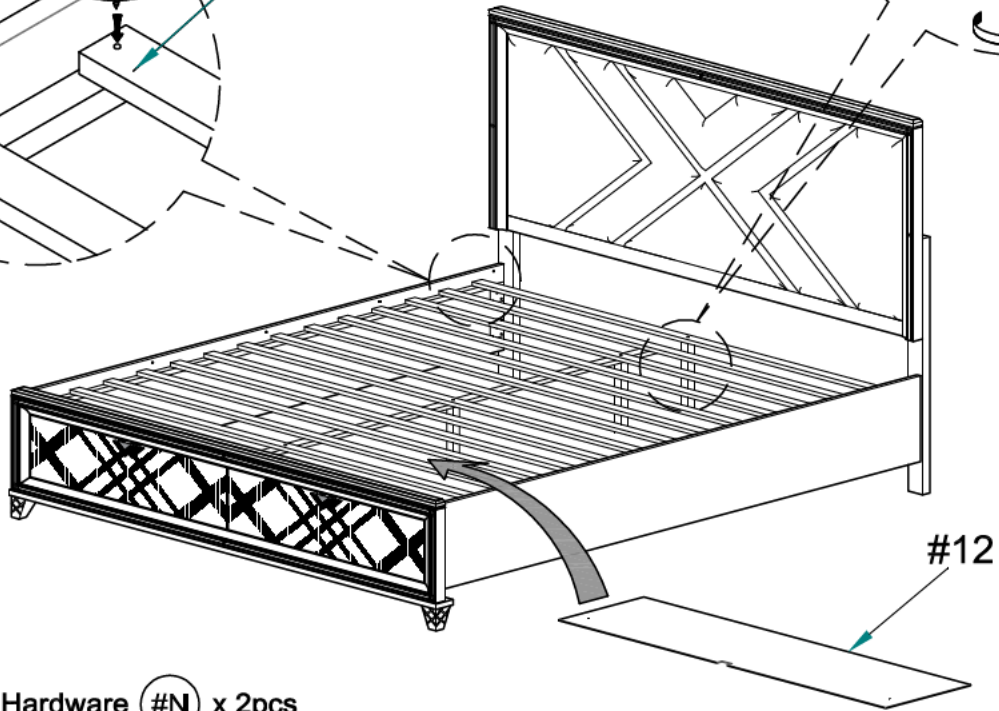
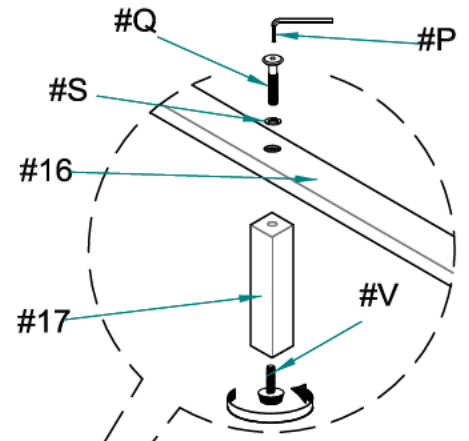
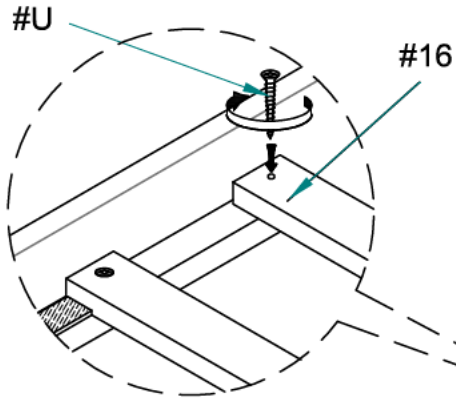

12

Hardware #N x 2pcs

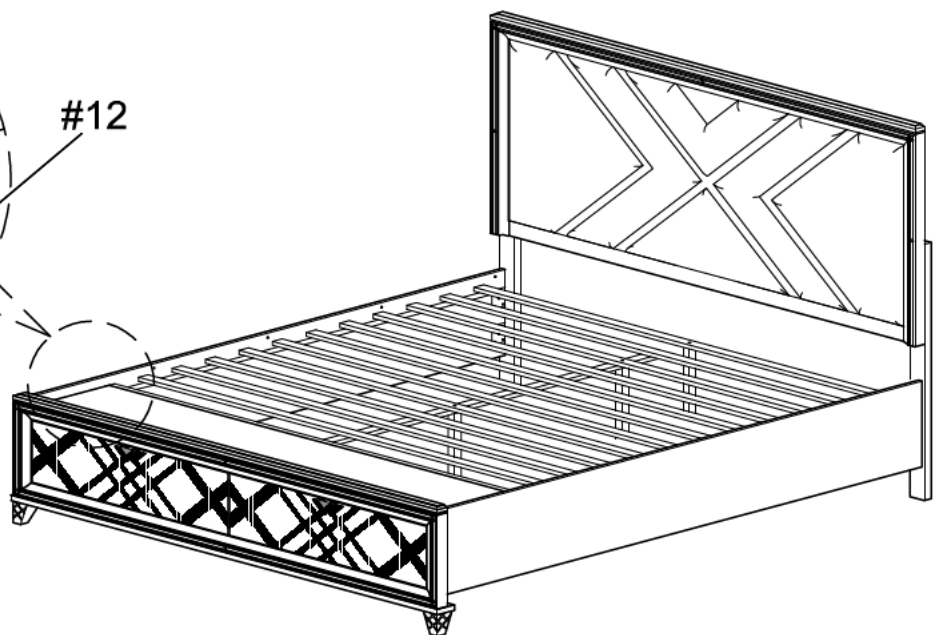
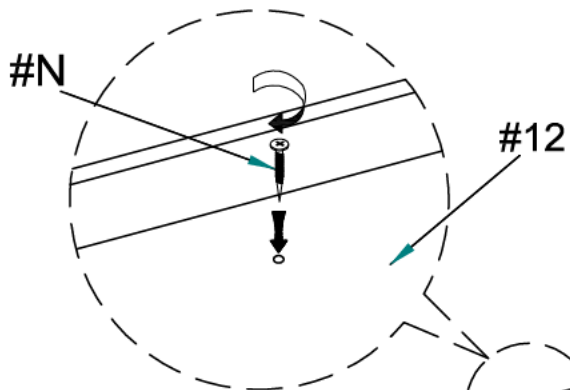

ASSEMBLY INSTRUCTIONS

13

Part #15 x 2pcs

Hardware #P x 1pc

Hardware #R x 10pcs

Hardware #S x 10pcs

Hardware #T x 10pcs

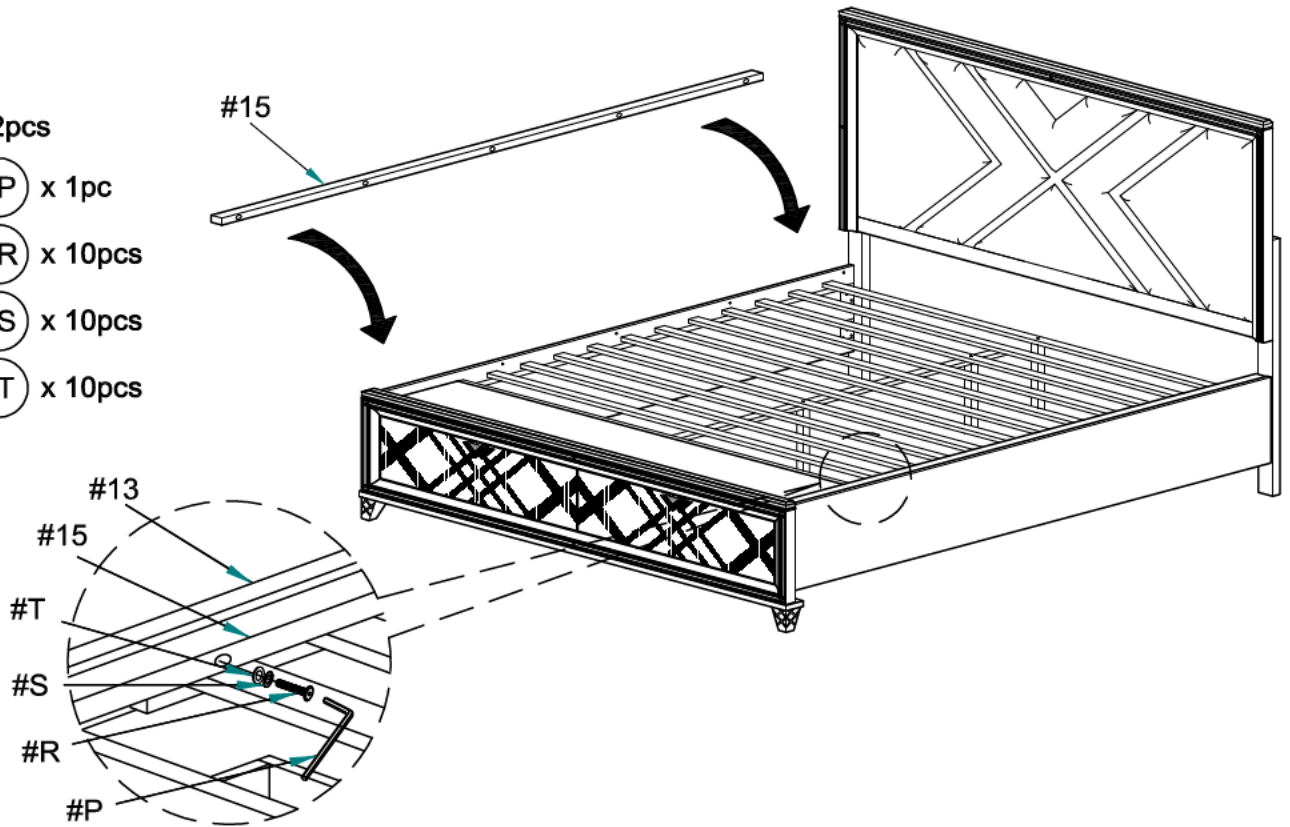

14

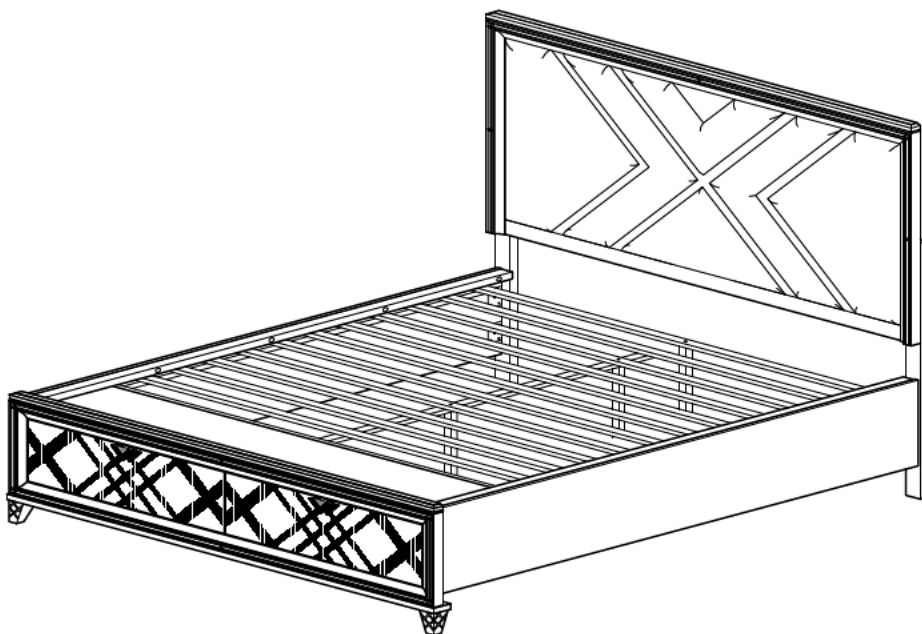

ASSEMBLY COMPLETED



Please ensure the furniture rests on an even and flat surface. If the product wobbles or feels loose, double-check all bolts and/or screws are properly tightened and secured.



Keep this handy!

Please retain this instruction manual and any order-related information for future reference.



Lift, don't drag!

To avoid damage to product please always LIFT the product when transporting or adjusting the placement.

ASSEMBLY INSTRUCTIONS

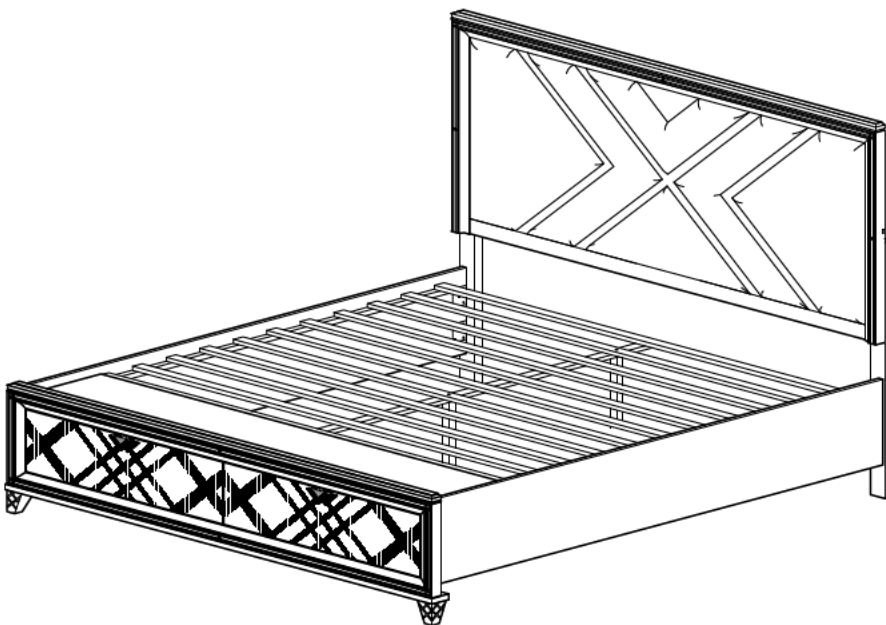

TOOLS REQUIRED

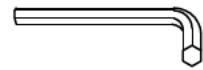

Allen Wrench

(Included)



**Phillips
Screwdriver**

(Not Included)



**3 - People
Recommended**

ASSEMBLY RATING



EASY —————> DIFFICULT

The Assembly Rating is a 5-point system showing the level of effort needed to assemble a specific product.

PRE ASSEMBLY INTRODUCTION

We understand building ready-to-assemble furniture can be a challenging experience for some. To help avoid confusion, we have provided some helpful tips that may speed up the process.



Teamwork

ALWAYS have at least two people to help with transporting and assembling the product to avoid potential injury and/or damage.



Suitable Location

Assembling near the area of the intended location is highly recommended.



Sufficient Space

Make sure you have enough space to move around during the assembly.



Avoid Scratches

Use cardboard, blankets or a carpeted area while assembling furniture to prevent scratches.



Flat Surface

Make sure the furniture rests on a flat and level surface with each leg evenly touching the floor.

ASSEMBLY AND CARE ADVICE



FAILURE TO FOLLOW THE GUIDELINES BELOW MAY RESULT IN INJURY AND/OR PROPERTY DAMAGE.



Position each part correctly and insert screws or bolts into their respective holes.

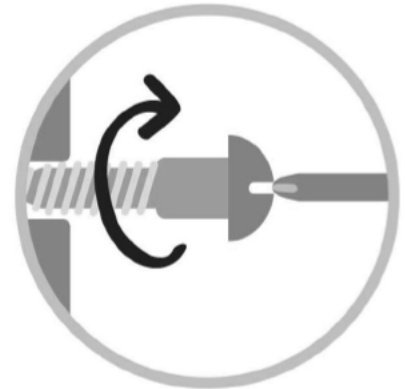

Turn clockwise to tighten and only tighten when step is completed or when instructed to do so.



Use the appropriate hand tools or power tools for assembly. Select steps, such as tightening screws and/or bolts, may require hand tools to avoid causing damage during assembly.



Save the instructions and store any supplied tools for later maintenance.



After two weeks, check and tighten any loose hardware and repeat again every six months thereafter.

IT IS THE USER'S RESPONSIBILITY TO MAINTAIN THE FURNITURE. THE HARDWARE MAY LOOSEN OVER TIME AND MAY CAUSE THE FURNITURE TO BE WOBBLY AND UNABLE TO SUPPORT ITS INTENDED WEIGHT CAPACITY. THIS MAY LEAD TO COLLAPSE AND MAY CAUSE SERIOUS INJURY.

KING BED



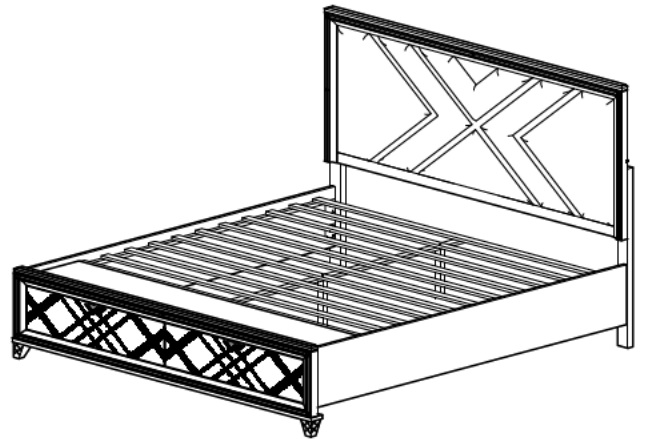

• Please keep instructions for future reference.
 • Check the quantity and irregularity of parts and hardware before you start.





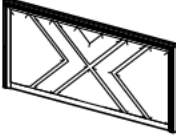



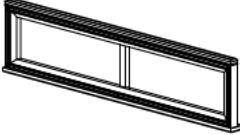

PARTS

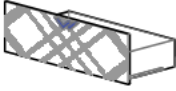
PART LIST OF HEADBOARD

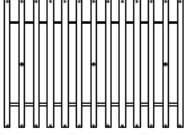
- | | | |
|---|--|--|
| 
#1 1pc
Headboard | 
#2 1pc
Headboard Leg - (R) | 
#3 1pc
Headboard Leg - (L) |
|---|--|--|

PART LIST OF FOOTBOARD

- | | | | | |
|--|--|--|--|---|
| 
#4 1pc
Footboard | 
#5 2pcs
Acrylic Leg | 
#6 1pc
Drawer Support Rail | 
#7 2pcs
Drawer | 
#8 2pcs
Drawer Base Panel |
| 
#9 13pcs
Roll Slat | 
#10 3pcs
Slat Support Leg
440mm x 30mm x 30mm | 
#11 1pc
Drawer Support Leg | 
#12 1pc
Slat Cover Panel | |

PART LIST OF SIDE RAIL

#13 2pcs



Side Rail

#14 1pc



Center Vertical Slat

HARDWARE

HARDWARE PACK IN HEADBOARD

#A 1pc



Allen Key

#B 6pcs



JCBC - M6 x 40mm

#C 6pcs



M6 Spring Washer

#D 6pcs



M6 Flat Washer

#E 1pc



AC Adapter

HARDWARE PACK IN FOOTBOARD

#F 1pc



Allen Key

#G 2pcs



JCBC - M6 x 16mm

#H 9pcs



JCBC - M6 x 35mm

#I 3pcs



JCBC - M6 x 60mm

#J 14pcs



M6 Spring Washer

#K 7pcs



M6 Flat Washer

#L 4pcs



1/4" Flat Washer

#M 26pcs



Screw 32mm

#N 2pcs











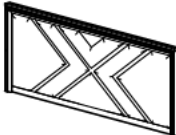







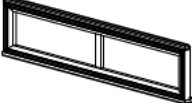







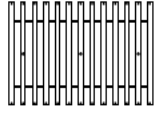

Screw 16mm

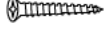
#O 4pcs

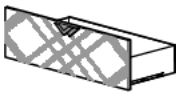
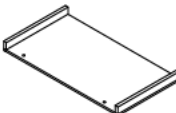

Adjustable Leveller

Designation		Part	Hardware
Headboard (1pc)	#1		 #A x 1pc  #B x 6pcs
Headboard Leg - (R) (1pc)	#2		 #C x 6pcs  #D x 6pcs
Headboard Leg - (L) (1pc)	#3		 #E x 1pc
Footboard (1pc)	#4		 #F x 1pc
Acrylic Leg (2pcs)	#5		 #G x 2pcs  #H x 9pcs  #I x 3pcs
Drawer Support Rail (1pc)	#6		 #J x 14pcs
Roll Slat (13pcs)	#9		 #K x 7pcs  #L x 4pcs
Slat Support Leg (3pcs)	#10		 #M x 26pcs
Drawer Support Leg (1pc)	#11		 #N x 2pcs  #O x 4pcs
Slat Cover Panel (1pc)	#12		
Side Rail (2pcs)	#13		
Center Vertical Slat (1pc)	#14		
Drawer (2pcs)	#7		
Drawer Base Panel (2pcs)	#8		

ASSEMBLY INSTRUCTIONS

1

Part #1 x 1pc

Part #2 x 1pc

Part #3 x 1pc

Hardware #A x 1pc

Hardware #B x 6pcs

Hardware #C x 6pcs

Hardware #D x 6pcs

Hardware #E x 1pc

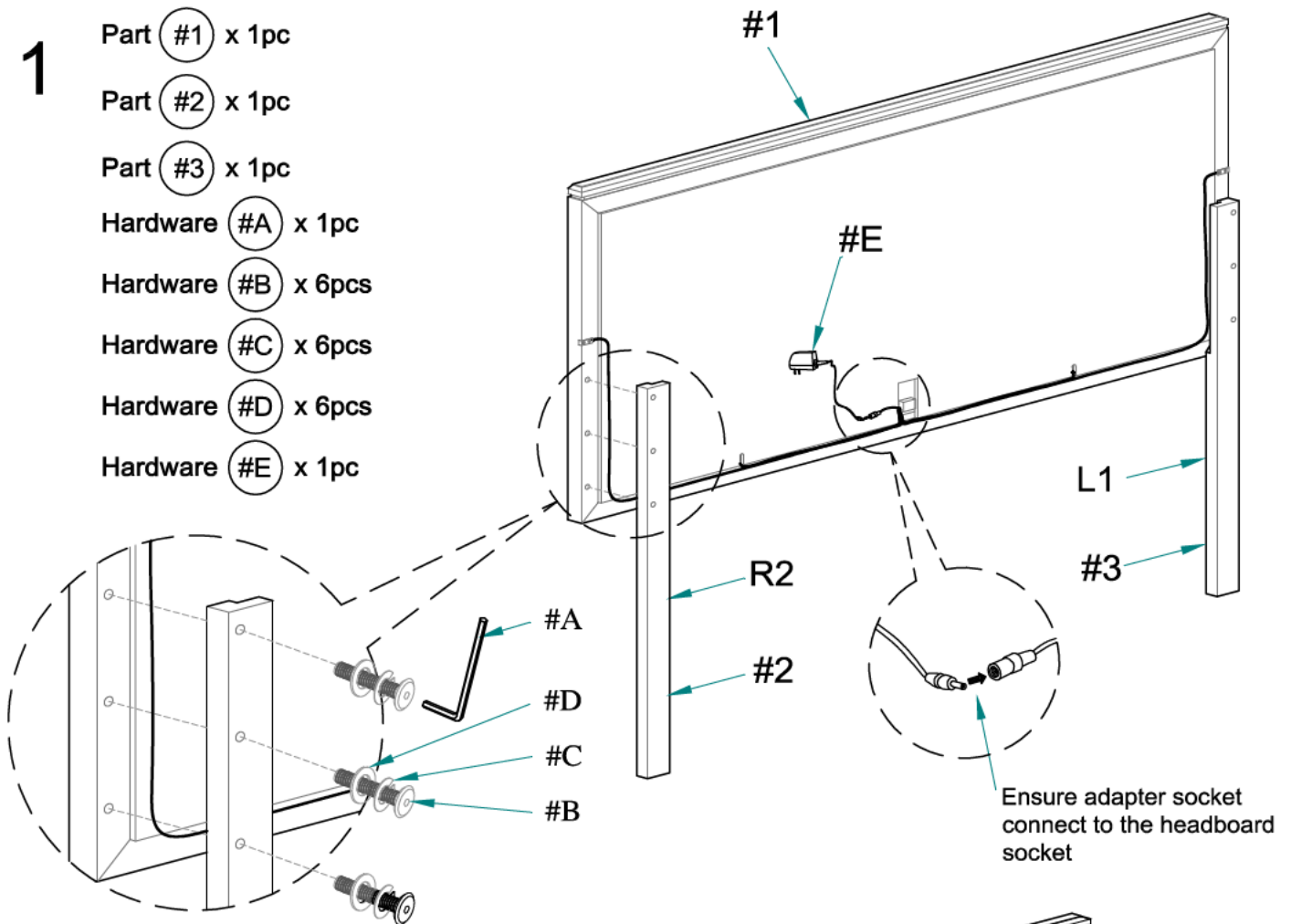

2

Part #1 x 1pc

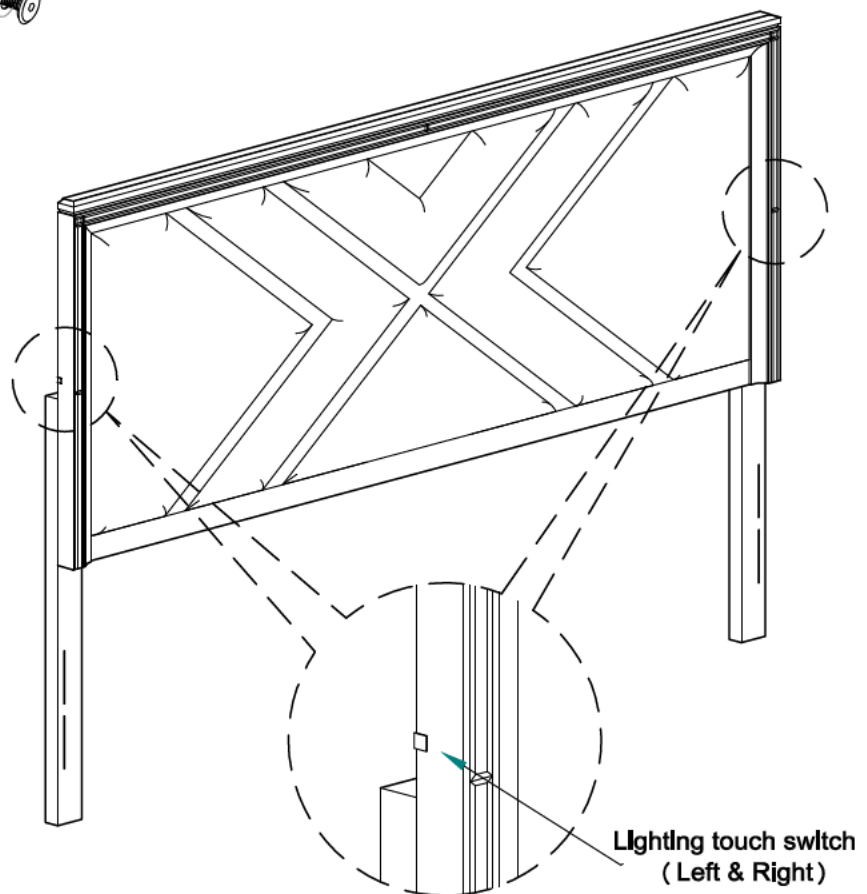

ASSEMBLY INSTRUCTIONS

3

Part #4 x 1pc

Part #5 x 2pcs

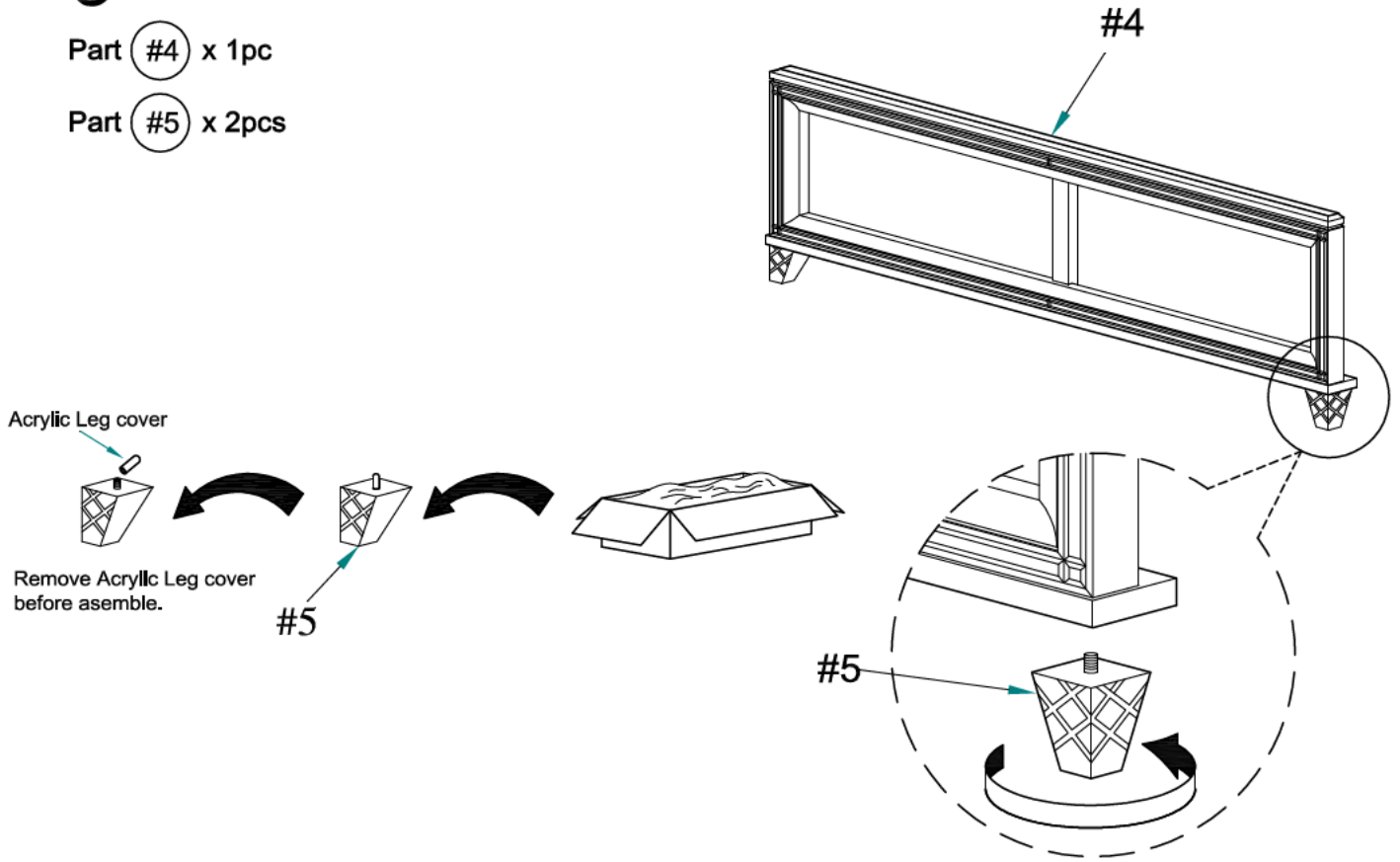

4

Part #1 x 1pc

Part #4 x 1pc

Part #13 x 2pcs

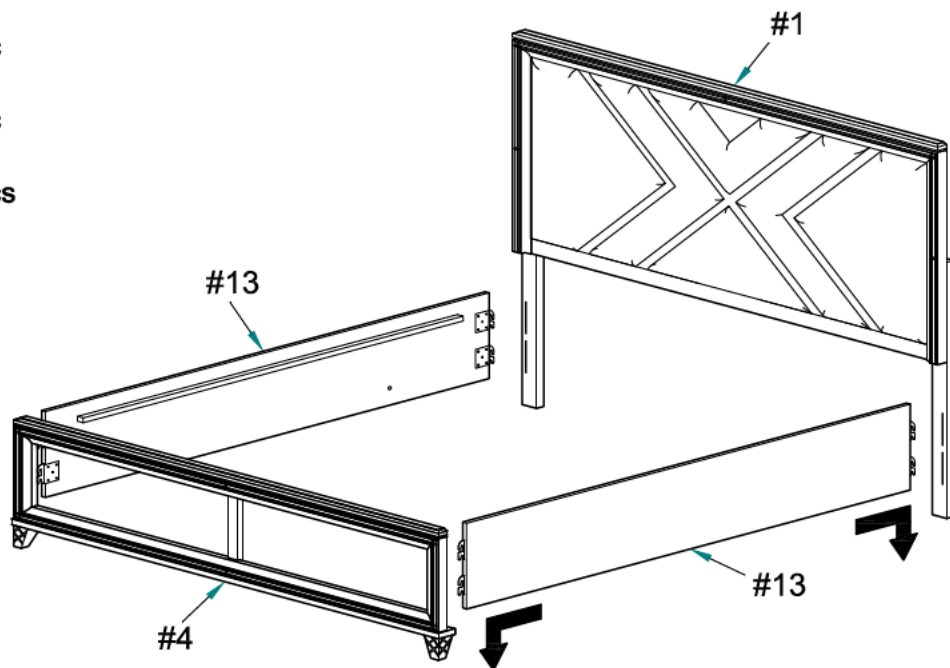

ASSEMBLY INSTRUCTIONS

5

Part #6 x 1pc

Hardware #F x 1pc

Hardware #G x 2pcs

Hardware #J x 2pcs

Hardware #K x 2pcs

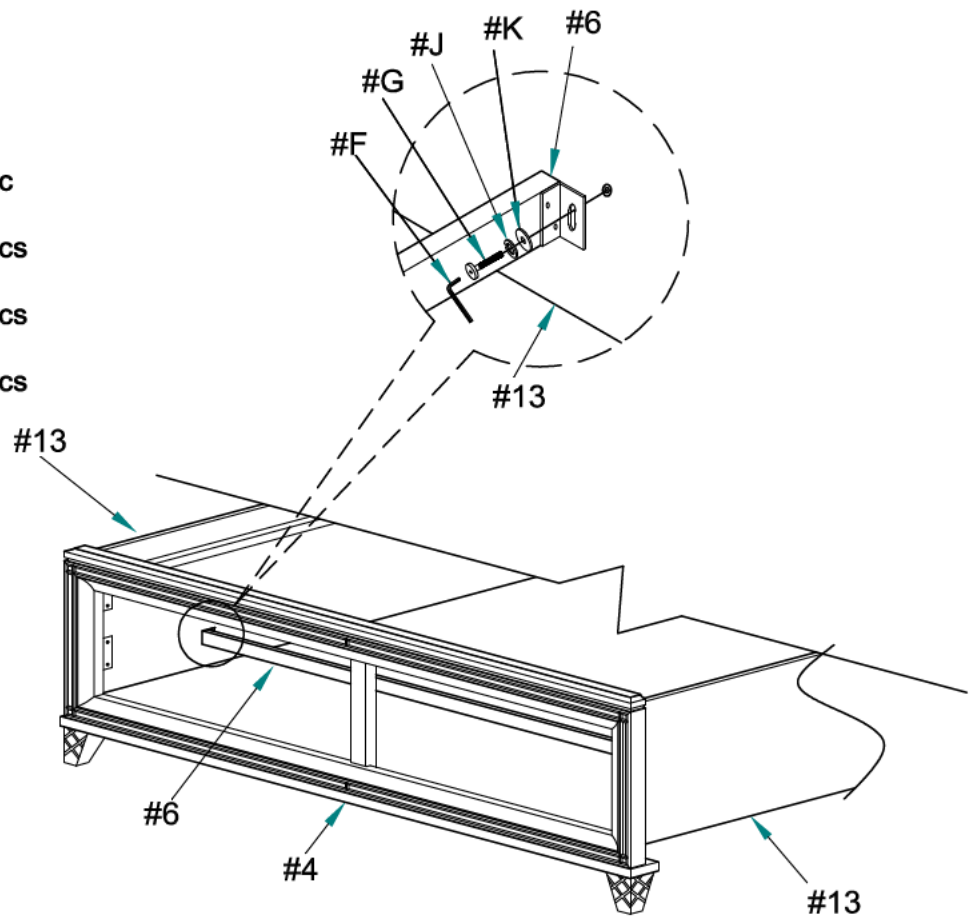

6

Make sure to fully extend rails to see the black switch on the rails.

Step to remove the drawer :

1. Pull the drawer
2. Using both hands,
 - Left hands side - pull up switch
 - Right hands side - pull down switch
3. Then remove the drawer from the drawer base panel

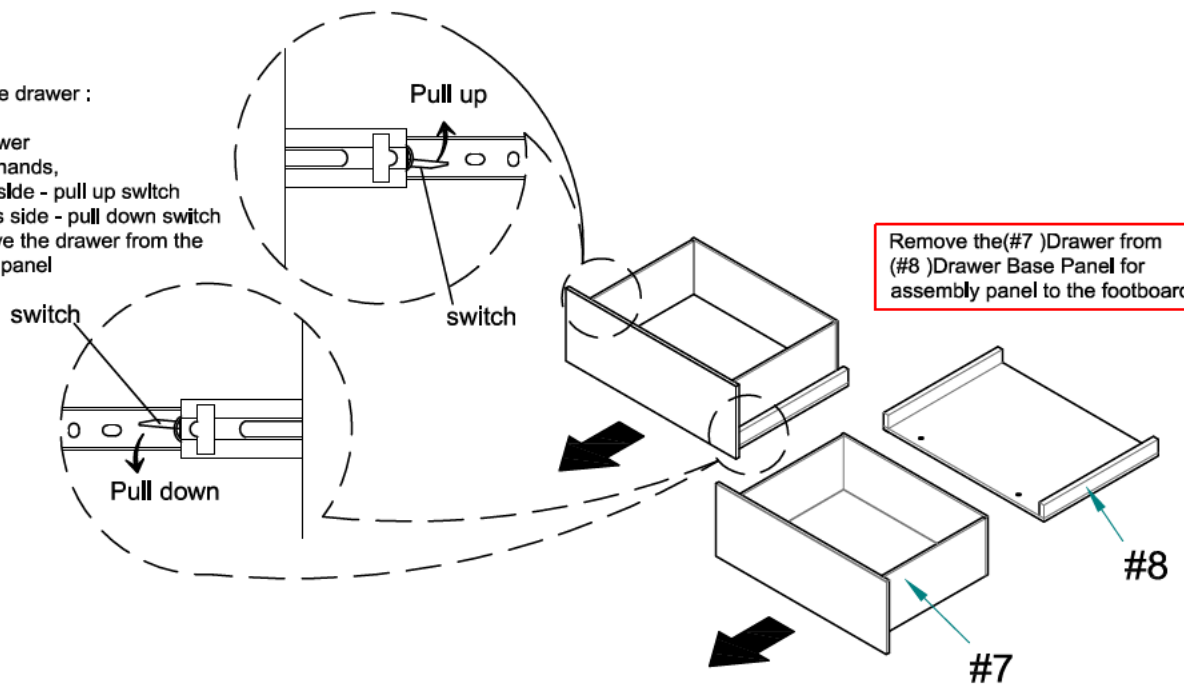

ASSEMBLY INSTRUCTIONS

7

- Part (#8) x 2pcs
- Hardware (#F) x 1pc
- Hardware (#H) x 8pcs
- Hardware (#J) x 8pcs
- Hardware (#K) x 4pcs
- Hardware (#L) x 4pcs

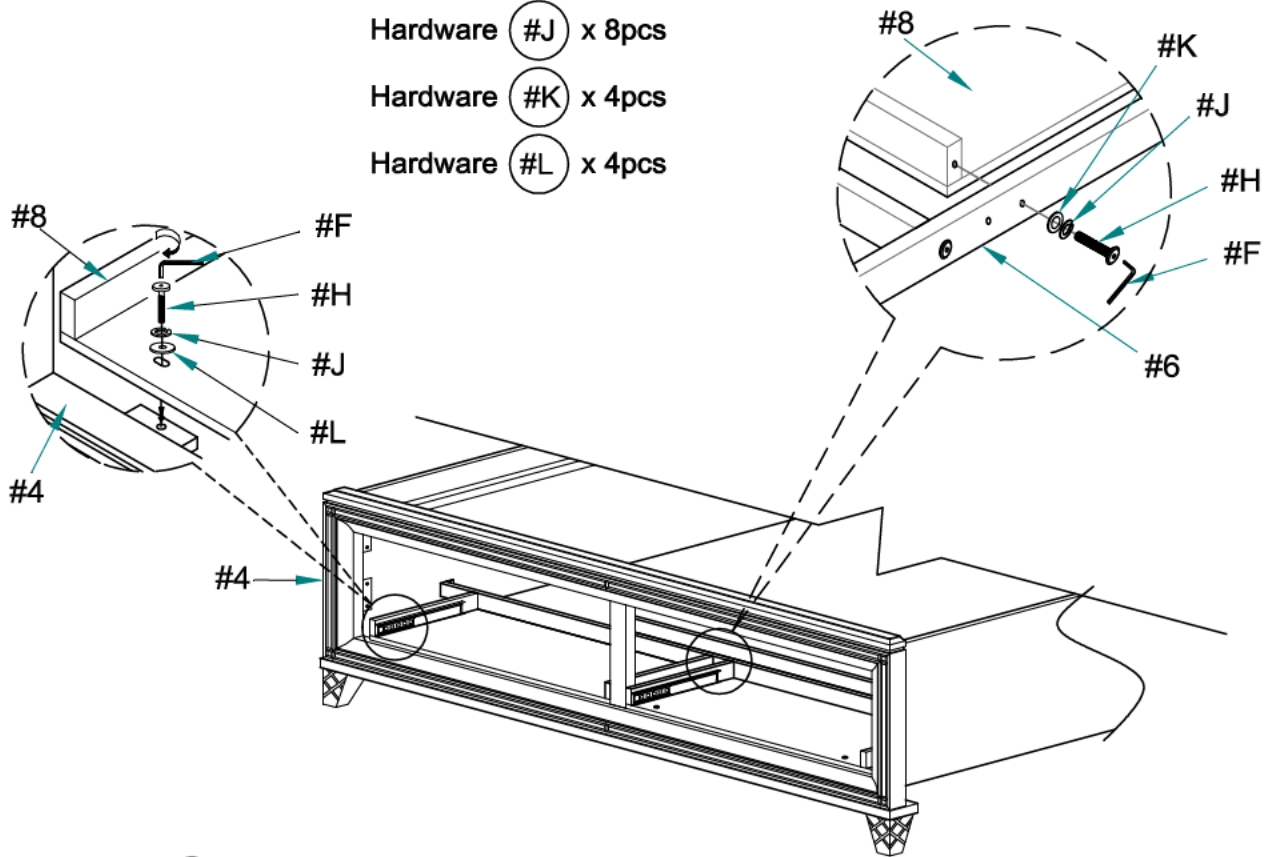

8

- Part (#11) x 1pc
- Hardware (#F) x 1pc
- Hardware (#H) x 1pc
- Hardware (#J) x 1pc
- Hardware (#K) x 1pc
- Hardware (#O) x 1pc

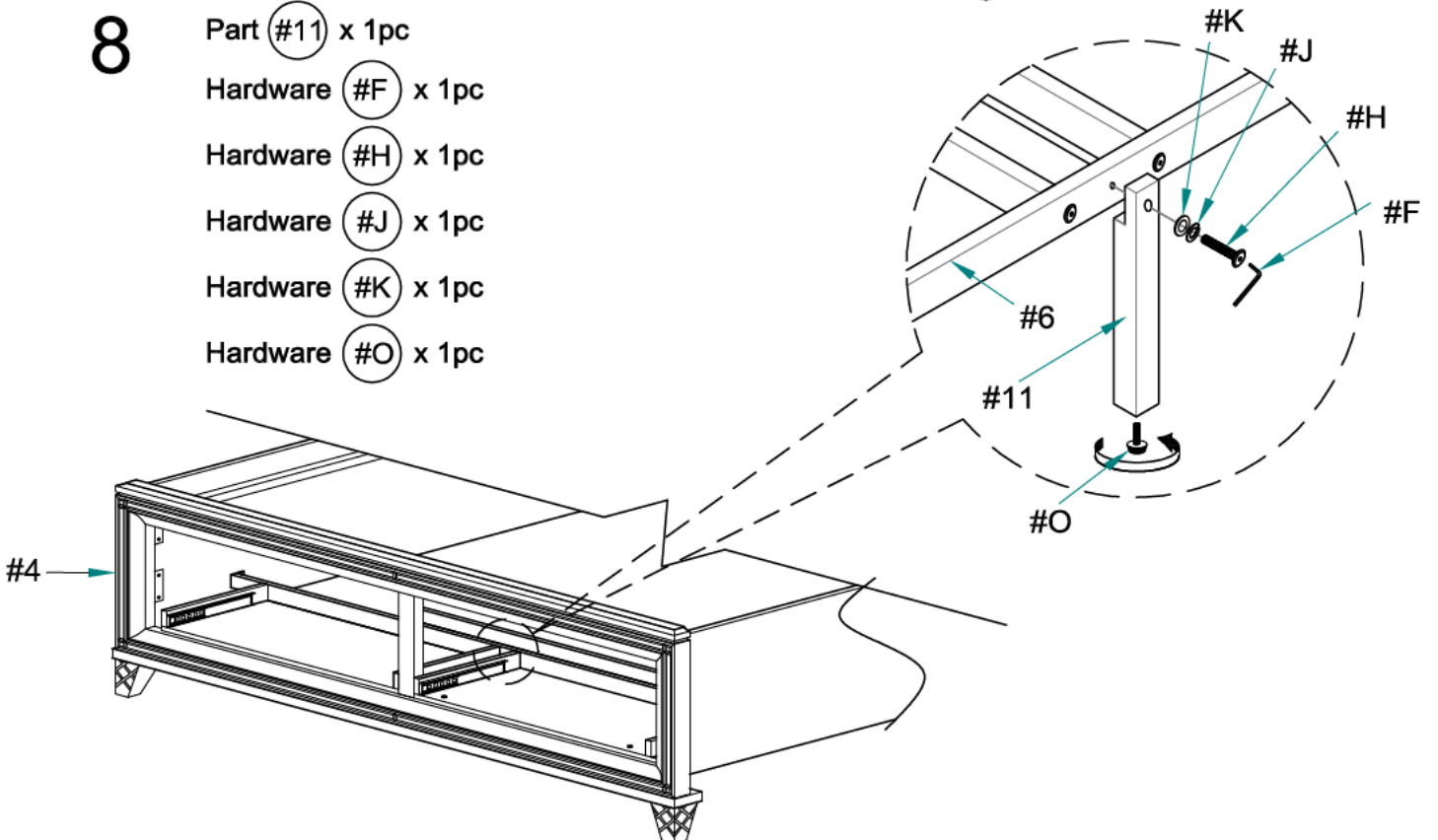

ASSEMBLY INSTRUCTIONS

9

Part **(#7)** x 2pcs

Step to install the drawer on the drawer base panel :

***Prefer 2 person to install the drawer

1. Adjust the ball bearing plate to the front as a diagram shows.
2. Then attach the drawer to the drawer base panel and install with carefully.

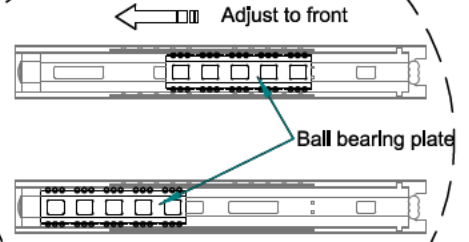

Insert the drawer (#7) to the footboard (#4)

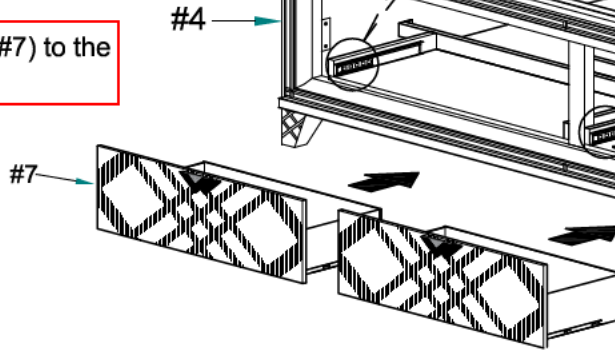

Align and connect the rails of the drawer base to the drawers.

10

Part **(#9)** x 13pcs Hardware **(#F)** x 1pc

Part **(#10)** x 3pcs Hardware **(#I)** x 3pcs

Part **(#12)** x 1pc Hardware **(#J)** x 3pcs

Part **(#14)** x 1pc Hardware **(#M)** x 26pcs

Hardware **(#O)** x 3pcs

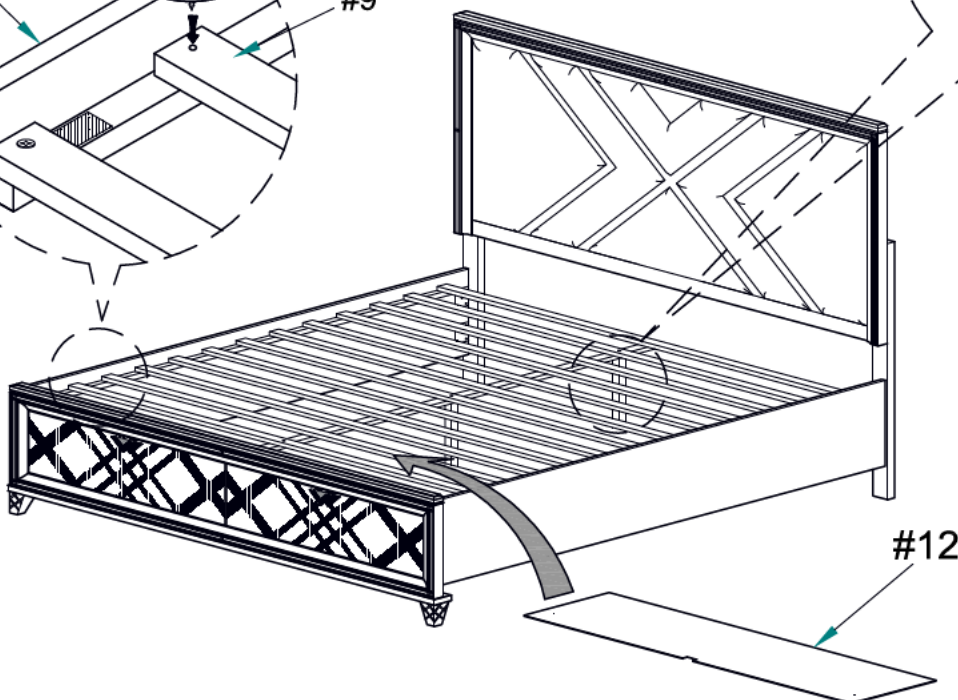
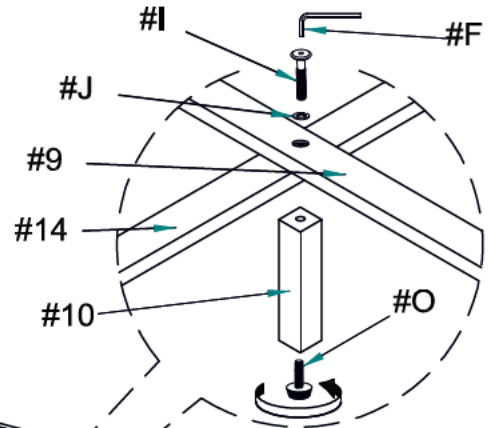
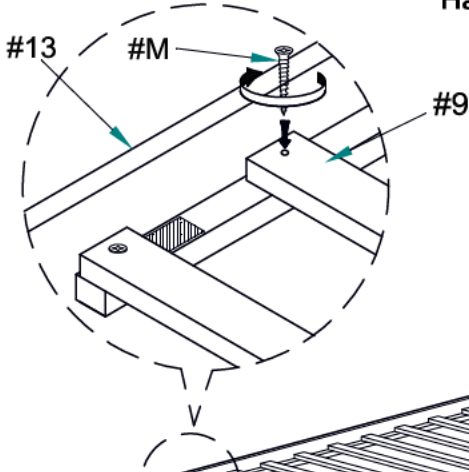

ASSEMBLY INSTRUCTIONS

11 Hardware (#N) x 2pcs

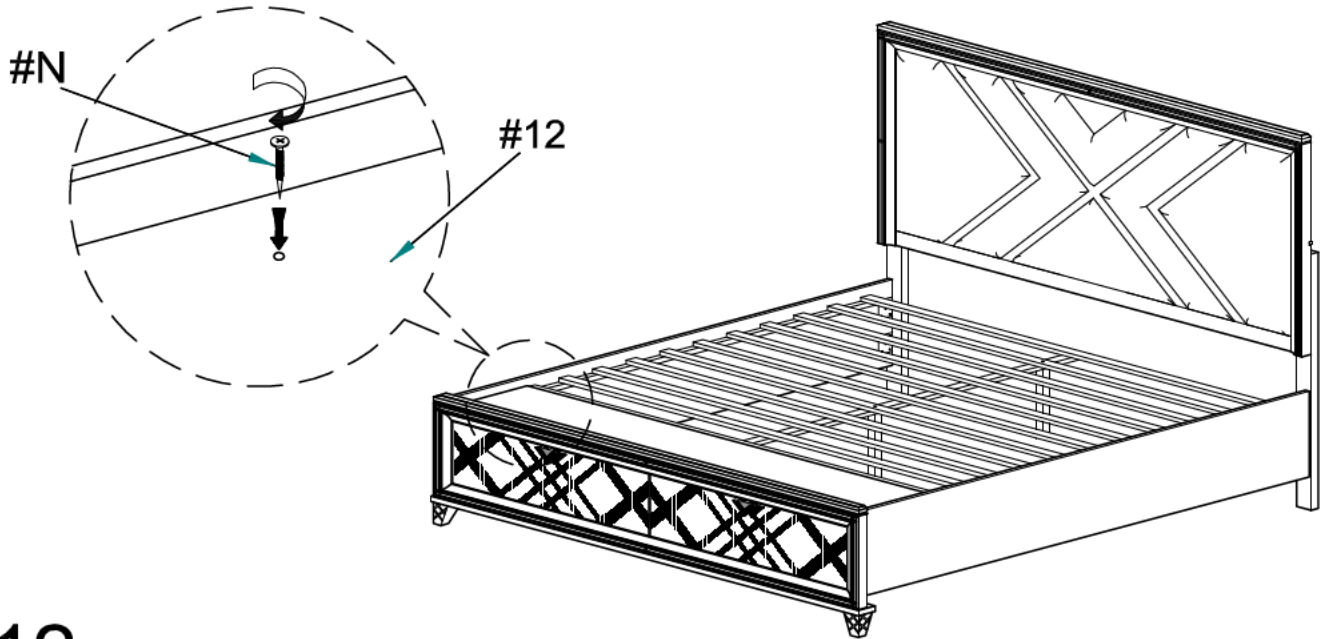

12

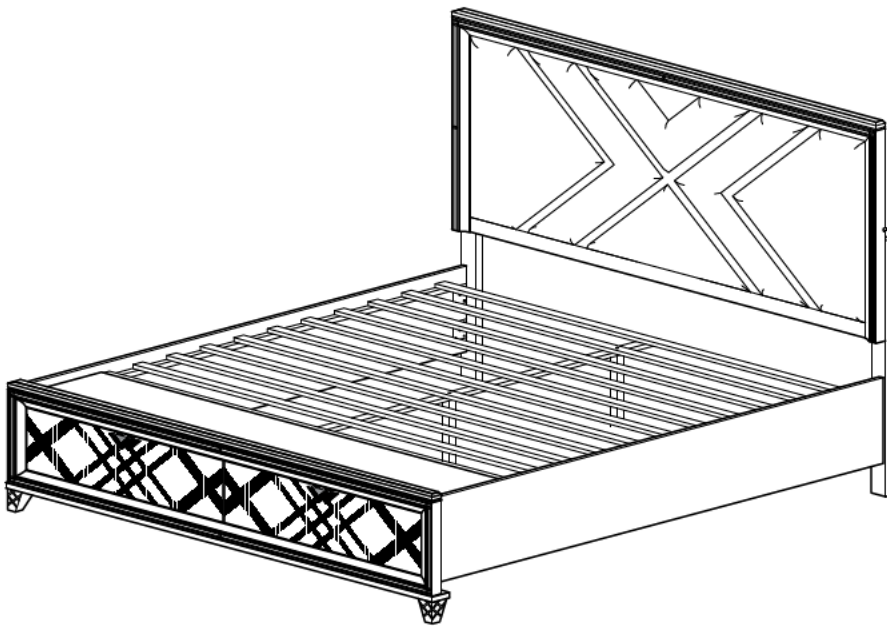

ASSEMBLY COMPLETED



Please ensure the furniture rests on an even and flat surface. If the product wobbles or feels loose, double-check all bolts and/or screws are properly tightened and secured.



Keep this handy!

Please retain this instruction manual and any order-related information for future reference.



Lift, don't drag!

To avoid damage to product please always LIFT the product when transporting or adjusting the placement.