

# Assembly Instructions

Caution : You must read this before you proceed

Please look the table top for hardware packs

## TABLE

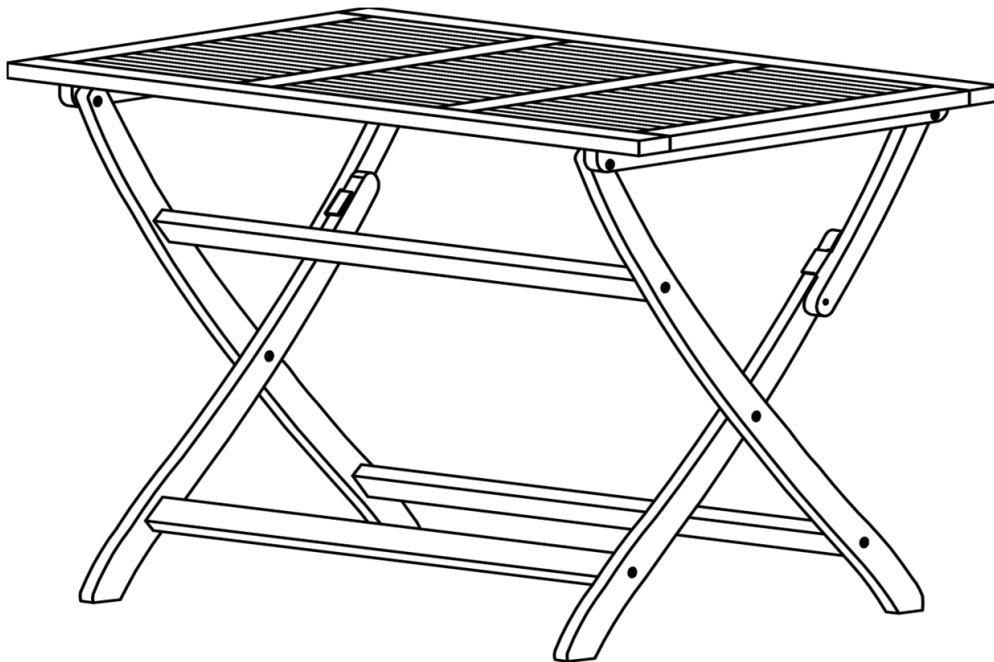

**CAUTION:** This Table is NOT a TOY



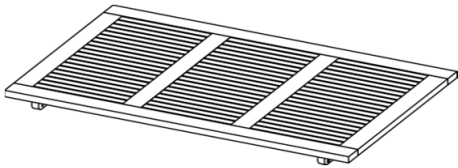
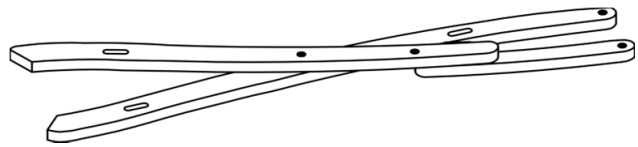
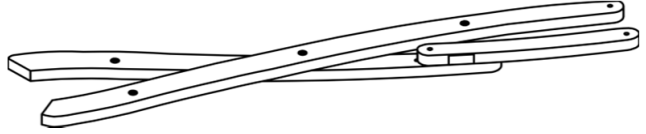
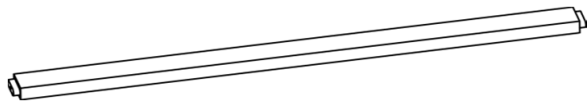
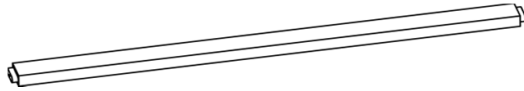

Keep your child/ children at bay in the process of assembly.

For turning the Table and to prevent damage to the Table ,02 persons may be needed to execute this action.

# Parts List

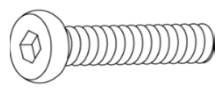
| Label | Picture   | Description       | QTY |
|-------|---|-------------------|-----|
| A     |    | Table Top         | 1   |
| B     |    | First Leg         | 1   |
| C     |    | Second Leg        | 1   |
| D     |   | Long Support Bar  | 2   |
| E     |  | Short Support Bar | 1   |

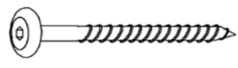



# Hardware

| Label | Picture   | Description                  | QTY |
|-------|---|------------------------------|-----|
| ①     |  | Bolt(M8×35mm)                | 5   |
| ②     |  | Sleeve Nut<br>(8×15mm)       | 5   |
| ③     |  | Flat Washer<br>(ø20×8.5×2mm) | 5   |
| ④     |  | Screw<br>(6×50mm)            | 7   |
| ⑤     |  | Allen Wrench                 | 2   |

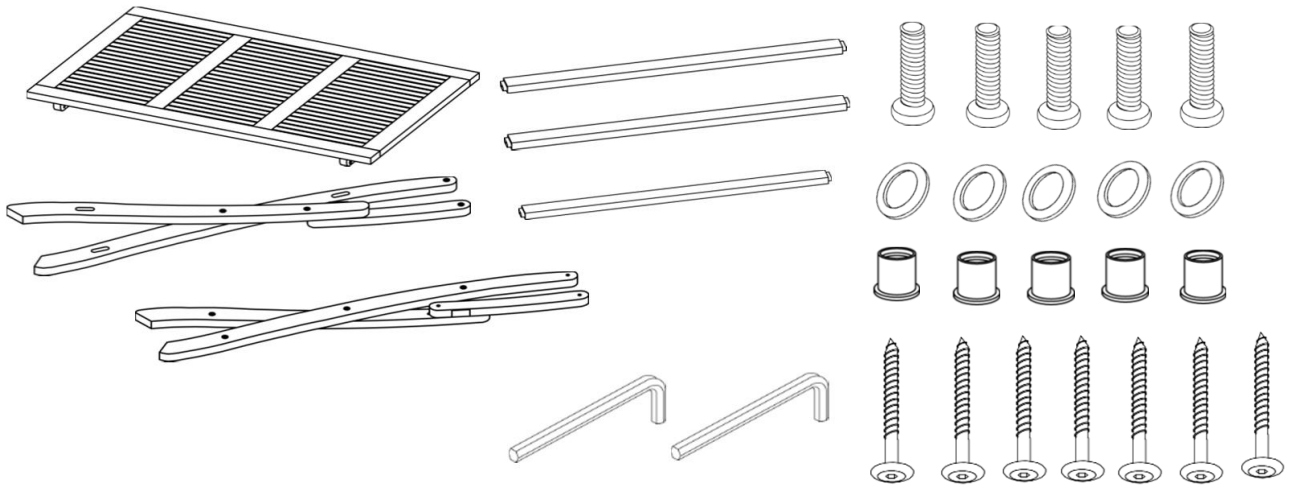
# Assembly Preparation

## Before Beginning Assembly:



-  • Read instructions, cover to cover-
-  • Have 2 adults on hand for assembly-
-  • Do not assemble on flooring or carpet-
-  • Assemble on a clean non-marring surface (packing foam)-
-  • Save all packaging until finished-

## Assembly Steps

### OVERVIEW

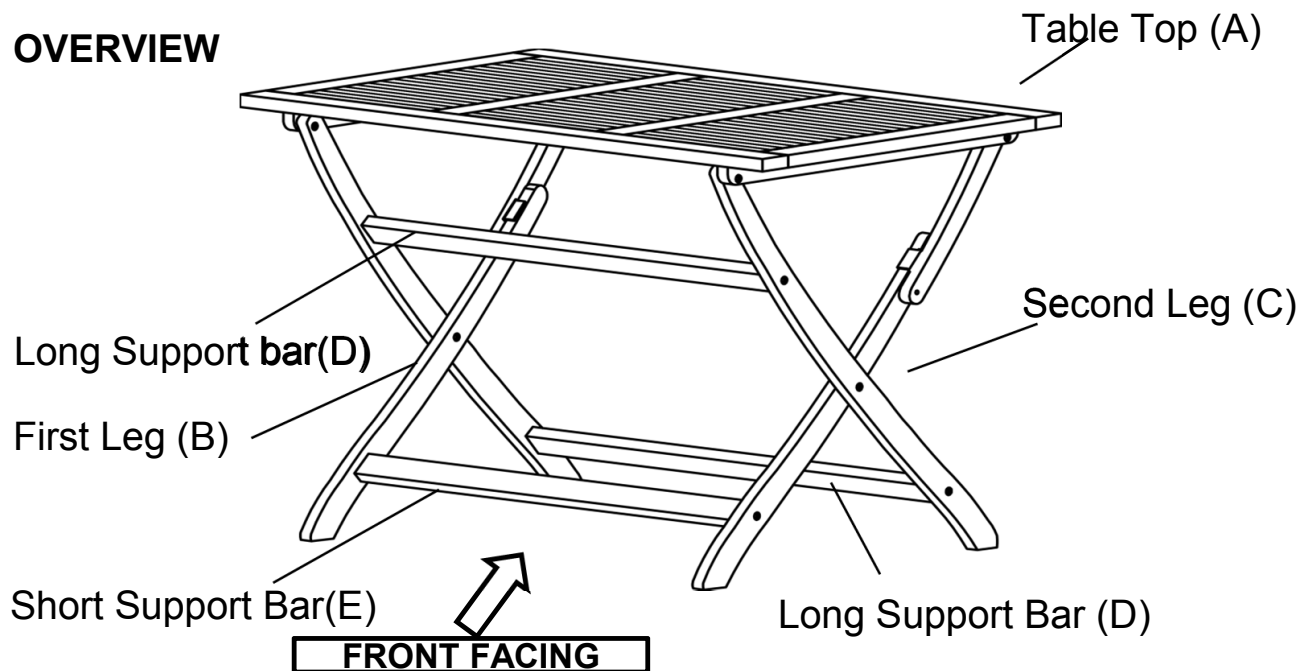

This Table has multiple parts and may require up to 30 minutes to assemble. To give you an overview of the Table parts, the above picture is to help you put the various parts into perspective. Please read through the instruction below to familiarise yourself with the parts and steps before assembly.

## Step 1

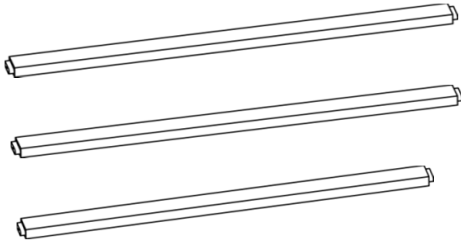
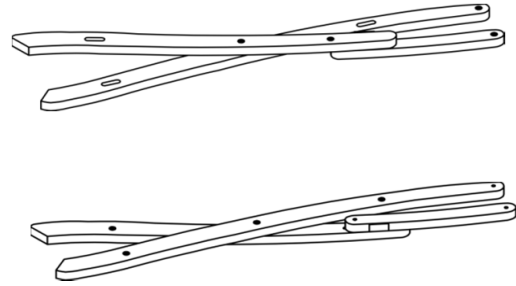
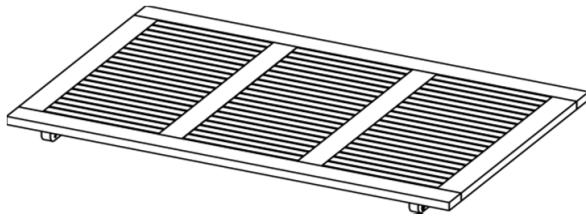

Unpack and place all parts on a clean, non-marring surface.

## Step 2

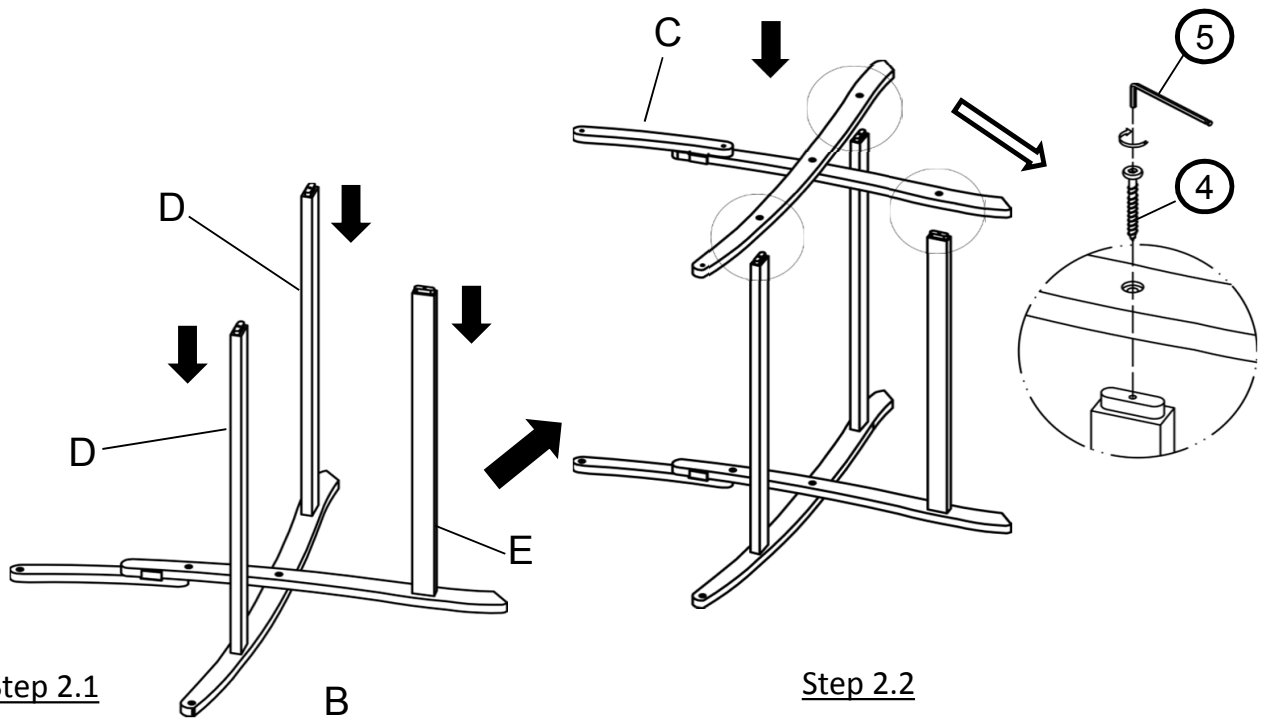

2.1) Position First Leg(B) and 3 Support Bar(D), (E).

2.2) Attach Second Leg(C) to 3 Support Bar(D), (E) by using 3 Screw(④) and Allen Wrench(⑤).

**Do not fully tighten the Screws.**

### Step 3

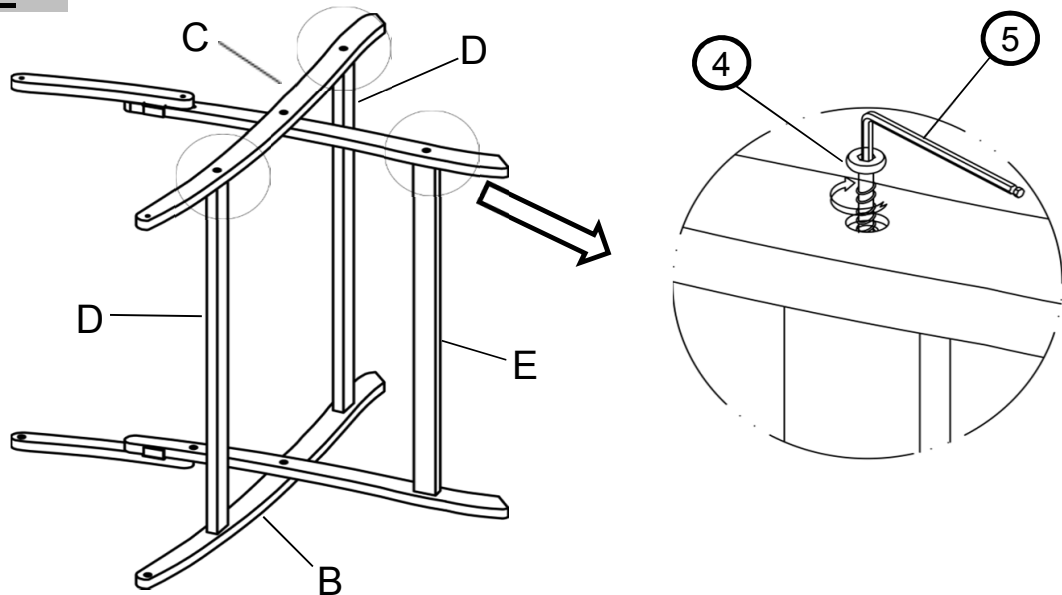

3.1) With assistance from your partners, turn the Leg frame into the other side.

3.2) Repeat the same process of Step 2.2 to secure First Leg(B) to 3 Support Bar(D),(E).

**Do not fully tighten the Screws.**

### Step 4

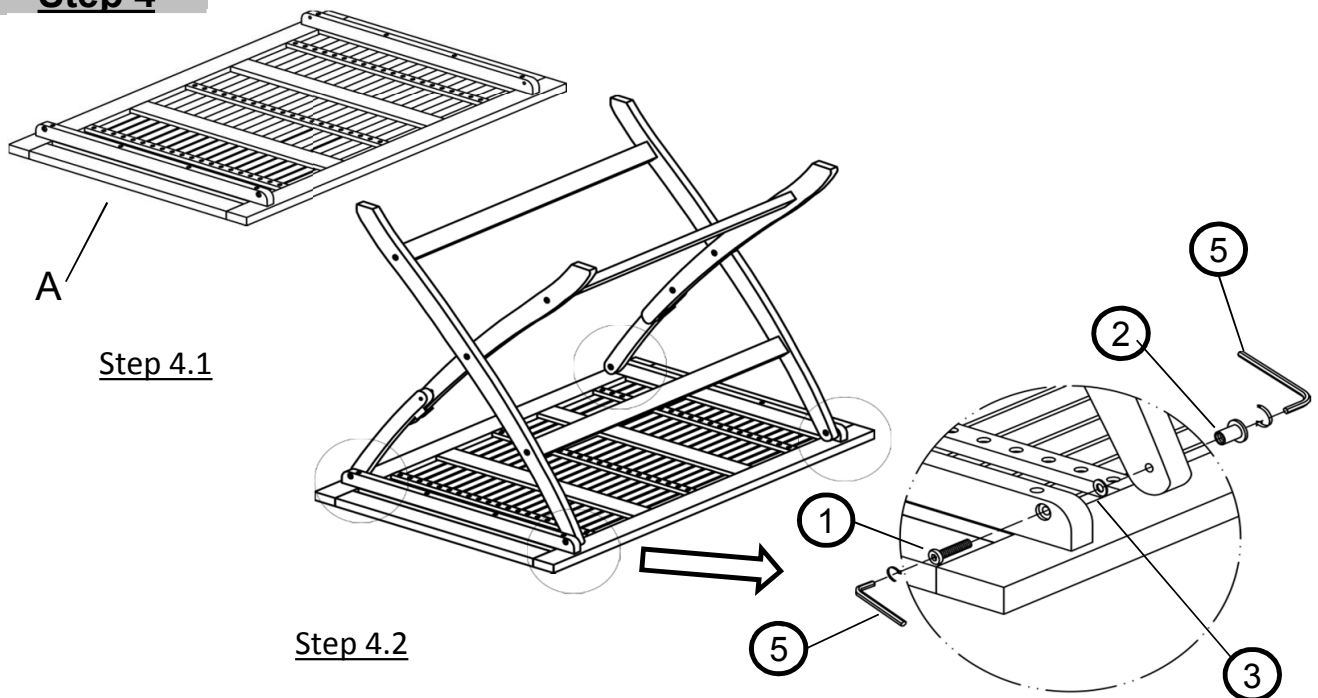

4.1) Turn the Table Top(A) up side down as shown in above picture.

4.2) Attach Leg frame in Step 3 to Table Top(A) by using Bolt(①), Sleeve Nut(②), Flat Washer(③) and Allen Wrench(⑤).

Repeat the same process with the other 3 positions.

**Do not fully tighten the Bolts.**

## **Step 5**

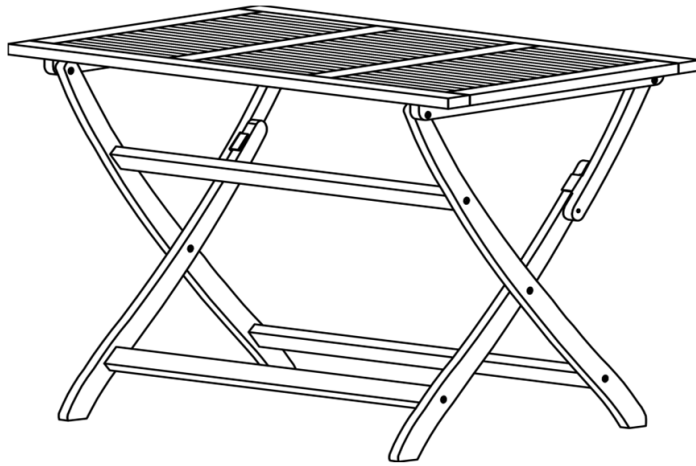

Turn the Table back to normal flat ground.

EXERT pressure, floorwards, onto the Table.

This pressure will help the Legs and Table Top reach alignment at all joints.

Check for wobbles.

In a sequential manner, gradually tighten all Bolts until evenly secured.

Inspect the Table and make sure all parts are adequately connected.

Your Table is ready for use.

This Table can only be used on a flat, level surface.



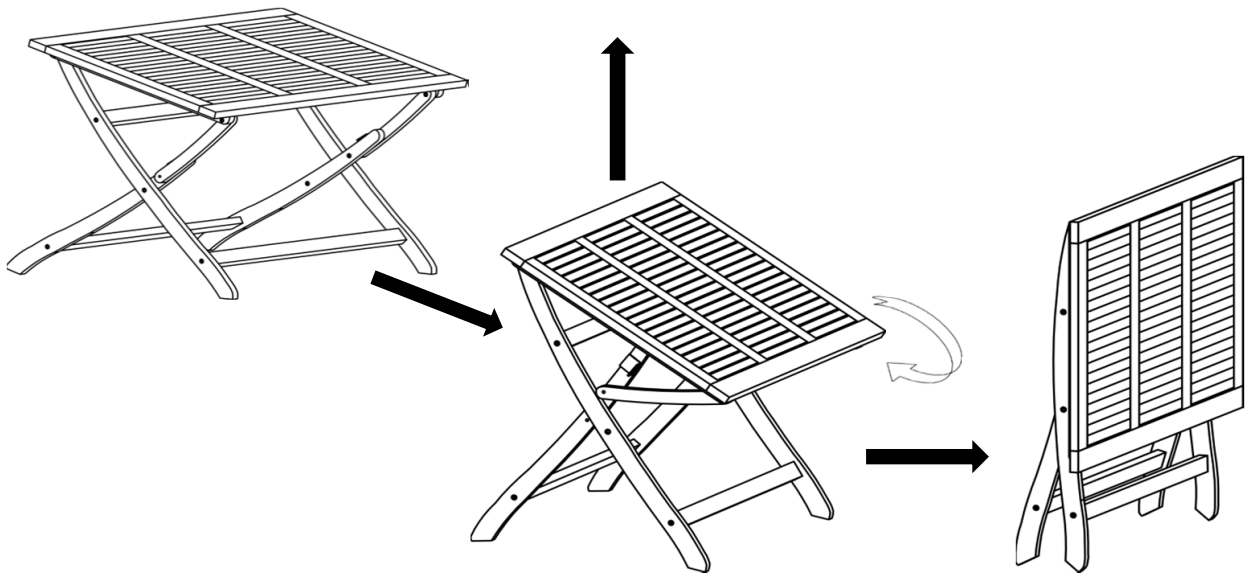















## **Step 6**



**Optionally, when you don't use the Table, you can fold the Table as picture shown.**

**To fold,** pull the Table top up and fold Leg Frame as indicated by the arrows, by hand, until the Table folds shut.

## Care & Maintenance

-   ● Do not put hot items directly on furniture surface
  -   ● Do not clean furniture with harsh cleansers or polish.
  -   ● To obtain the longest lifespan of your outdoor products, minimizing exposure to direct sunlight is recommended.
  -   ● Children should not climb or jump on the furniture.
  -   ● Do not write on furniture without a padded barrier to protect the surface.
  -   ● To obtain the longest lifespan of your outdoor products, avoid extended and lengthy exposure to rain, snow, and direct sunshine. Whenever possible cover the product and /or place under patio or awnings.
  -   ● Not for commercial use. For residential use only .
  -   ● Stains may be removed with mild soap solution and damp cloth.
- 
-   ● Dust and pick-up spills using a clean, non-colored, lint-free cloth .