

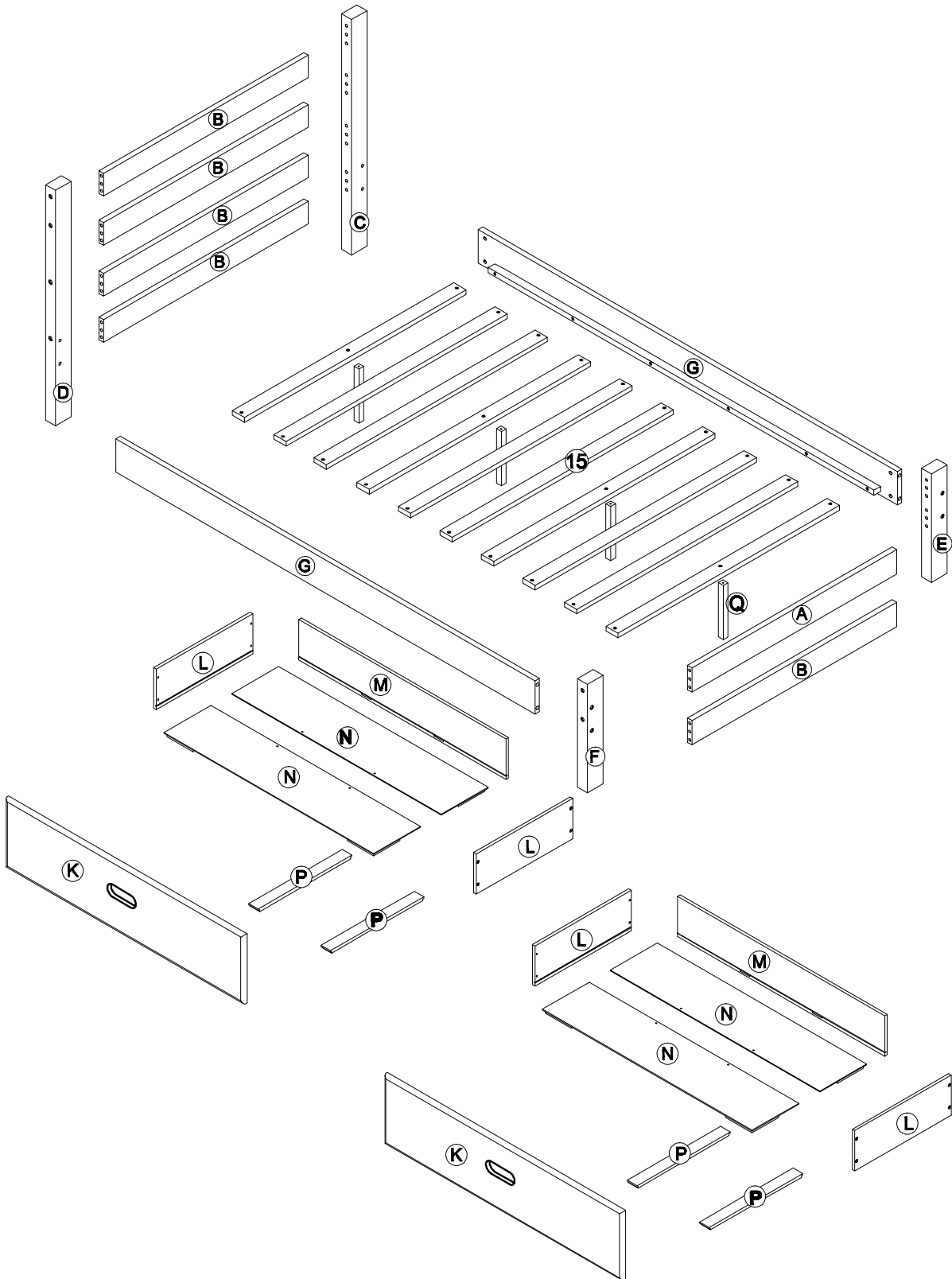



ASSEMBLY INSTRUCTIONS





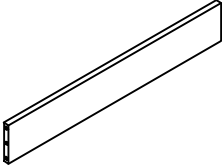
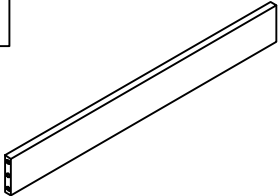
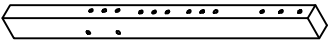
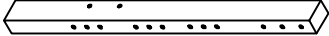

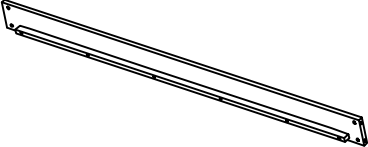
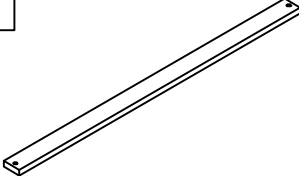
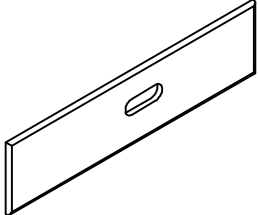
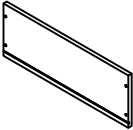
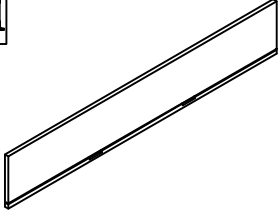
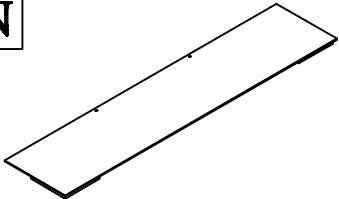

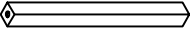
Detail View

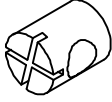
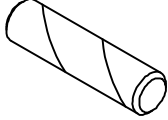

PART LISTS

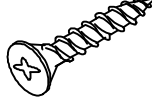
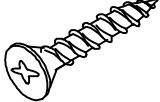
A 	B 	C 
Footboard top rail 1pc	Headboard & Footboard horizontal rail 5pcs	Headboard leg (left side) 1pc
D 	E 	F 
Headboard leg (Right side) 1pc	Footboard leg (left side) 1pc	Footboard leg (Right side) 1pc
G 	H 	K 
Side rail 2pcs	Slat - 10pcs	Drawer Front - 2pcs
L 	M 	N 
Drawer side panel -4pcs	Drawer back panel - 2pcs	Drawer bottom panel -4pcs
P 	Q 	
Drawer bottom support - 4pcs	Center support leg- 4pcs	

HARDWARE LISTS

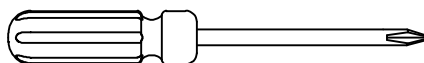

<p>1</p> 	<p>2</p> 	<p>3</p> 
<p>Long Bolt: 1/4" x 85mm (8 pcs)</p>	<p>Hole bolt Ø 1/4"x15mm (8 pcs)</p>	<p>Wood dowel Ø10 x 30mm (28 pcs)</p>
<p>4</p> 	<p>5</p> 	<p>6</p> 
<p>Screw #8 x 30mm (20 pcs)</p>	<p>Wheel 8 pcs</p>	<p>Screw Ø3 x 15mm (24 pcs)</p>
<p>7</p> 	<p>8</p> 	<p>9</p> 
<p>Screw Ø4 x 25mm (16pcs)</p>	<p>Allen key 4mm (1pc)</p>	<p>Bolt screw : 1/4" x110mm (12pcs)</p>
<p>10</p>  <p>Bolt 1/4" x 30mm-4pcs</p>		

ASSEMBLY SCREW DRIVER REQUIRED (NOT INCLUDED)

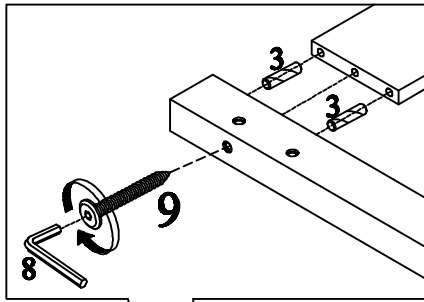

STEP 1



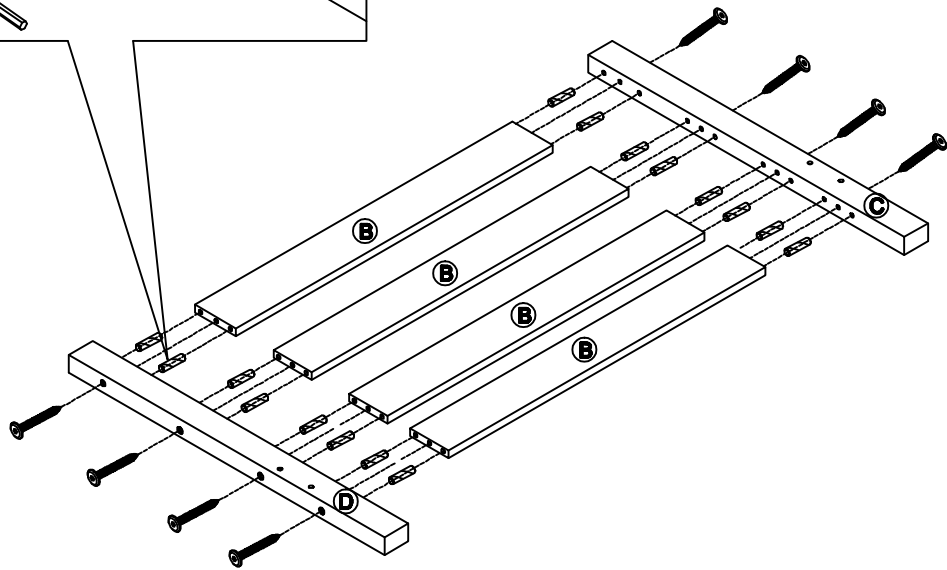

9		3	
8PCS		16PCS	



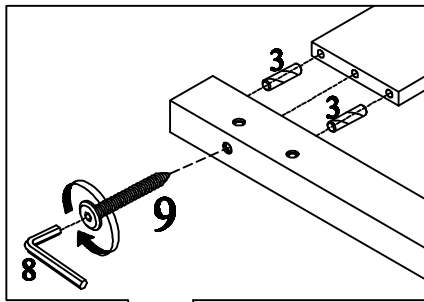

STEP 2

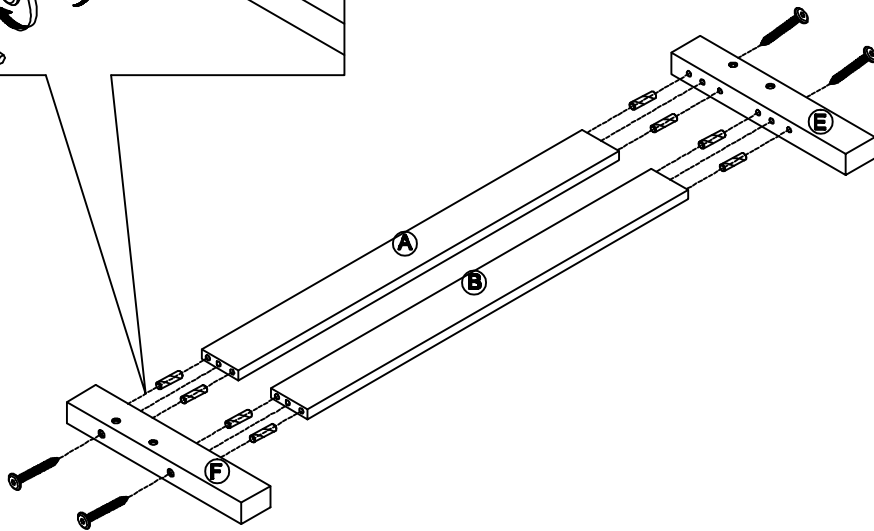

9		3	
4PCS		8PCS	



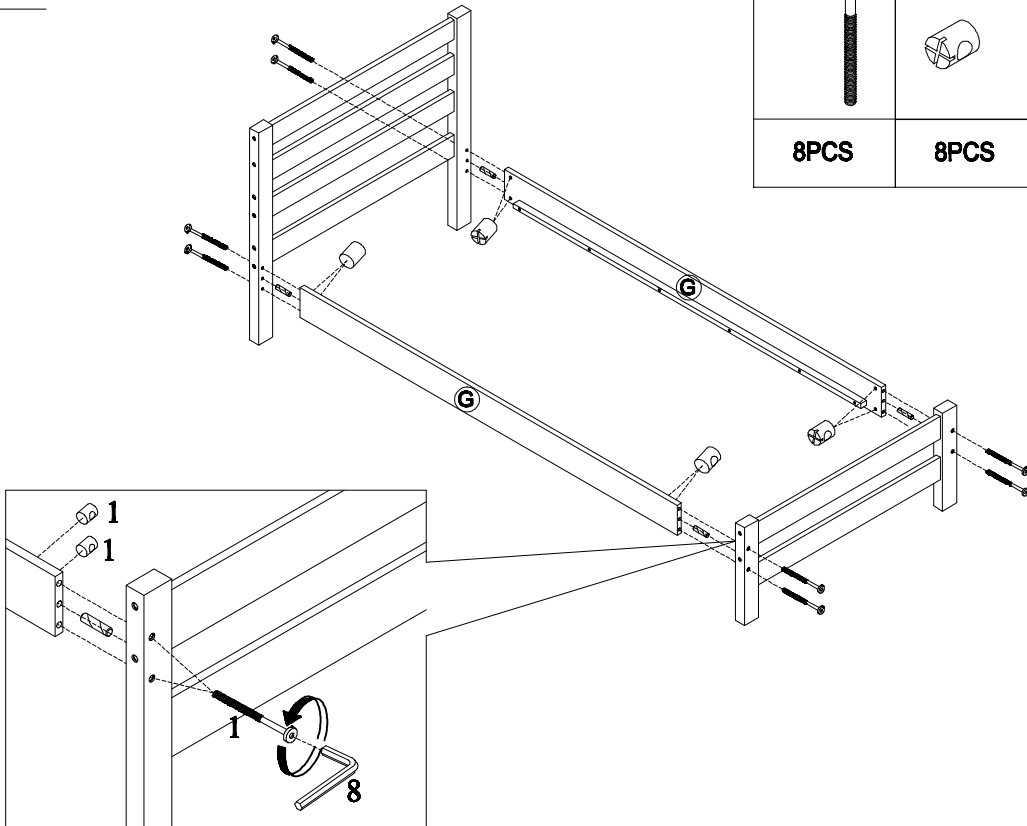

STEP 3

1		2		3	
8PCS		8PCS		4PCS	



STEP 4

4		10	
20PCS		4 PCS	

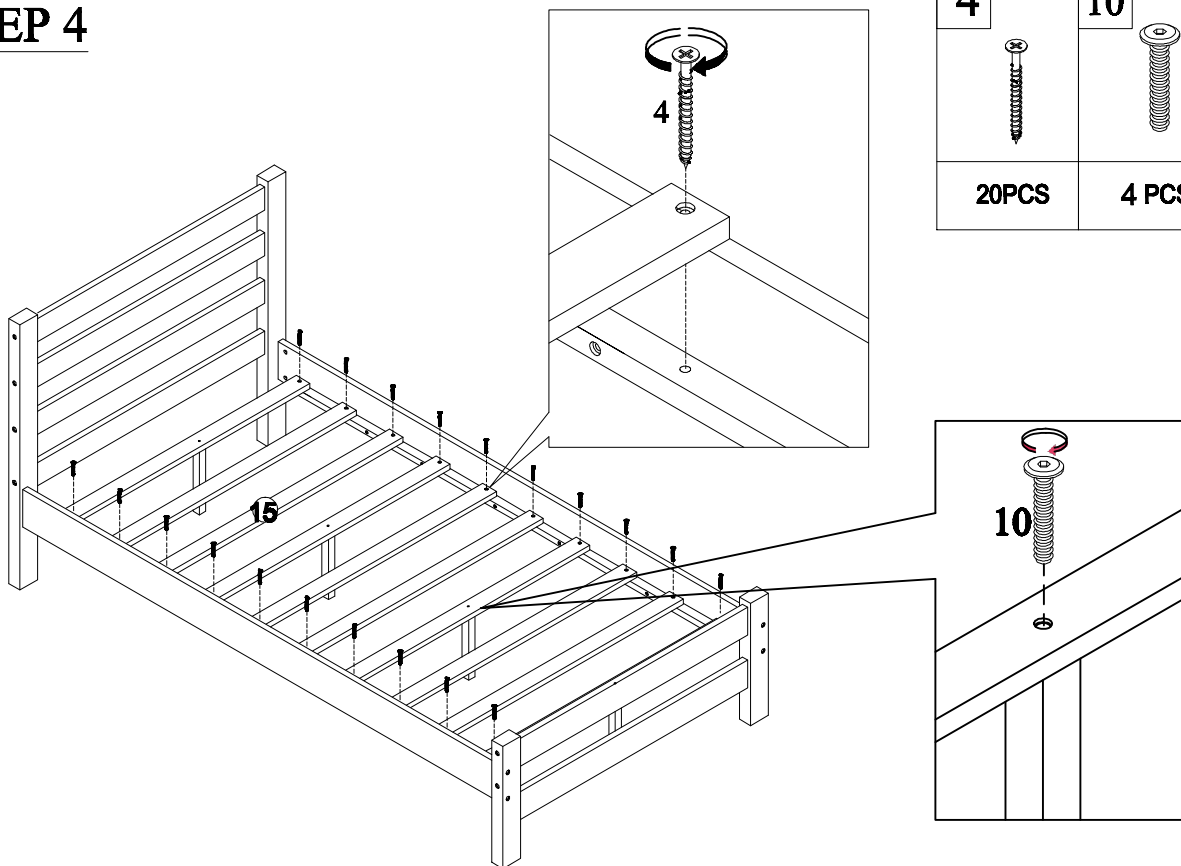

STEP 5

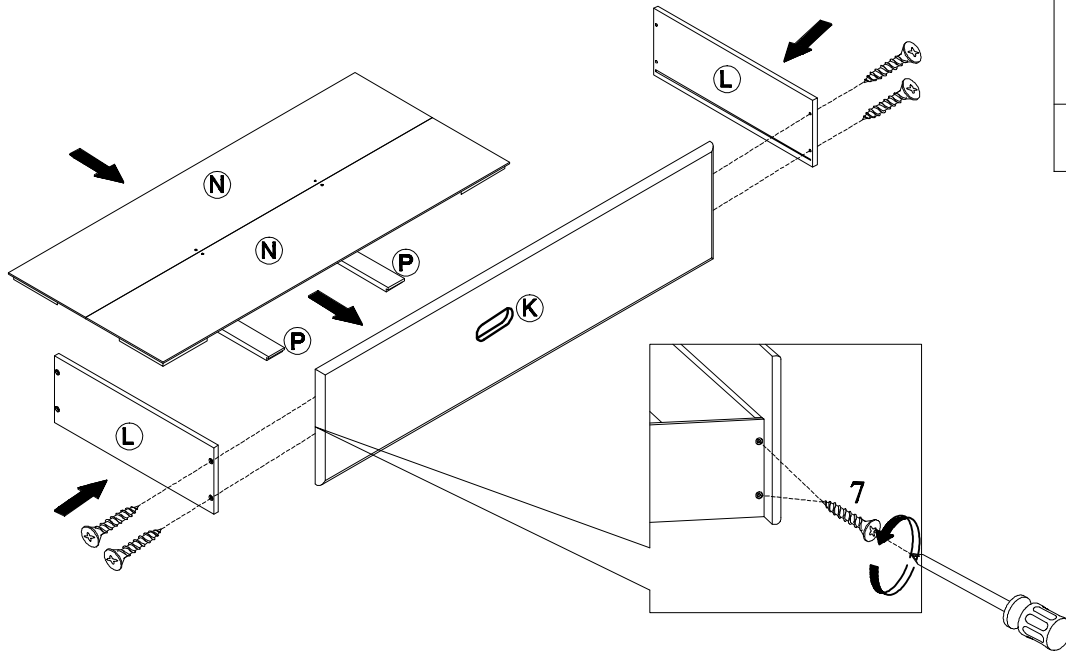

7

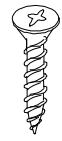

4PCS

STEP 6

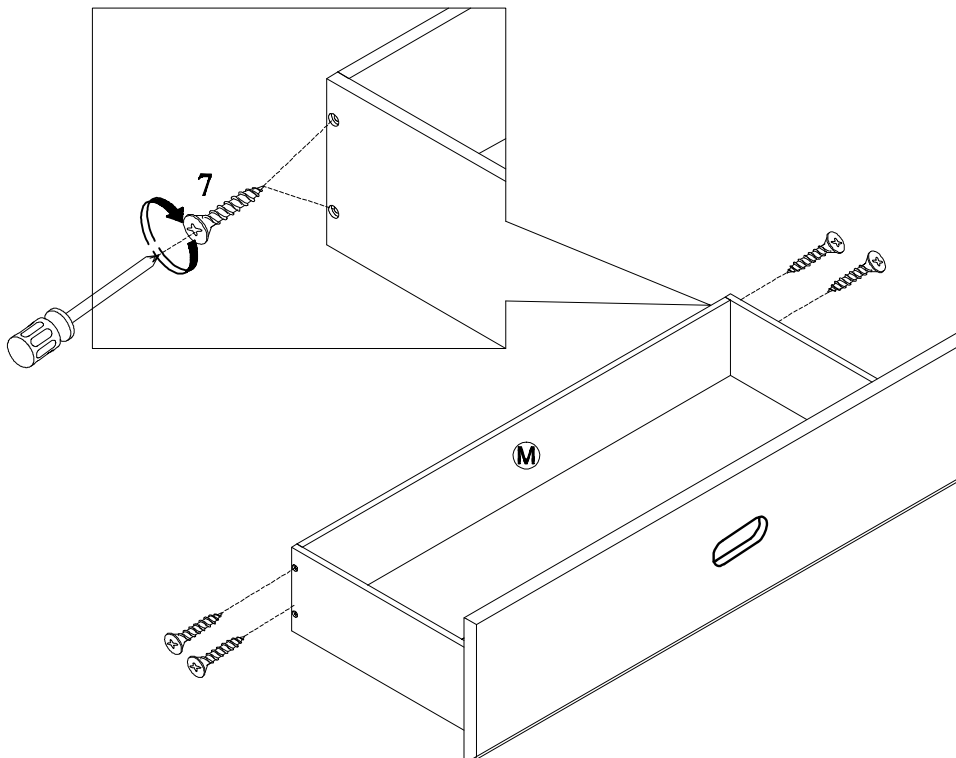

7



4PCS

STEP 7

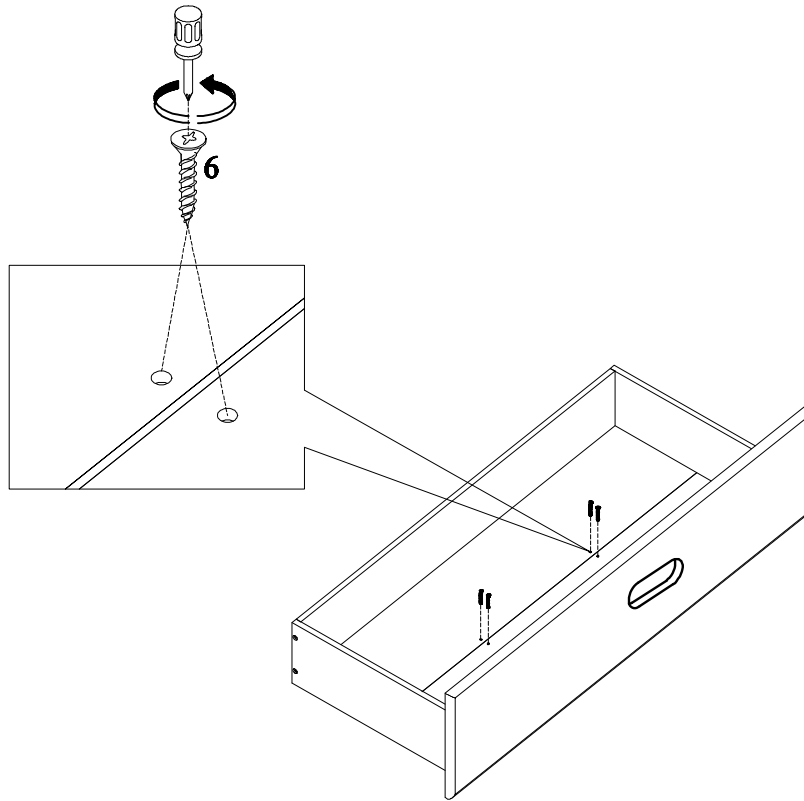

6

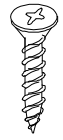

4PCS

STEP 8

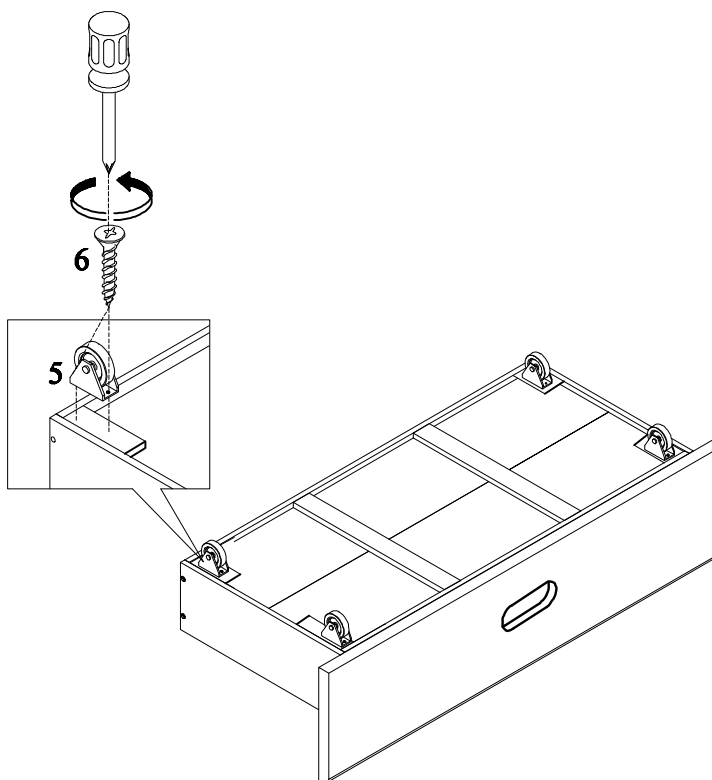

5



4PCS

6

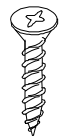

8PCS

STEP 9

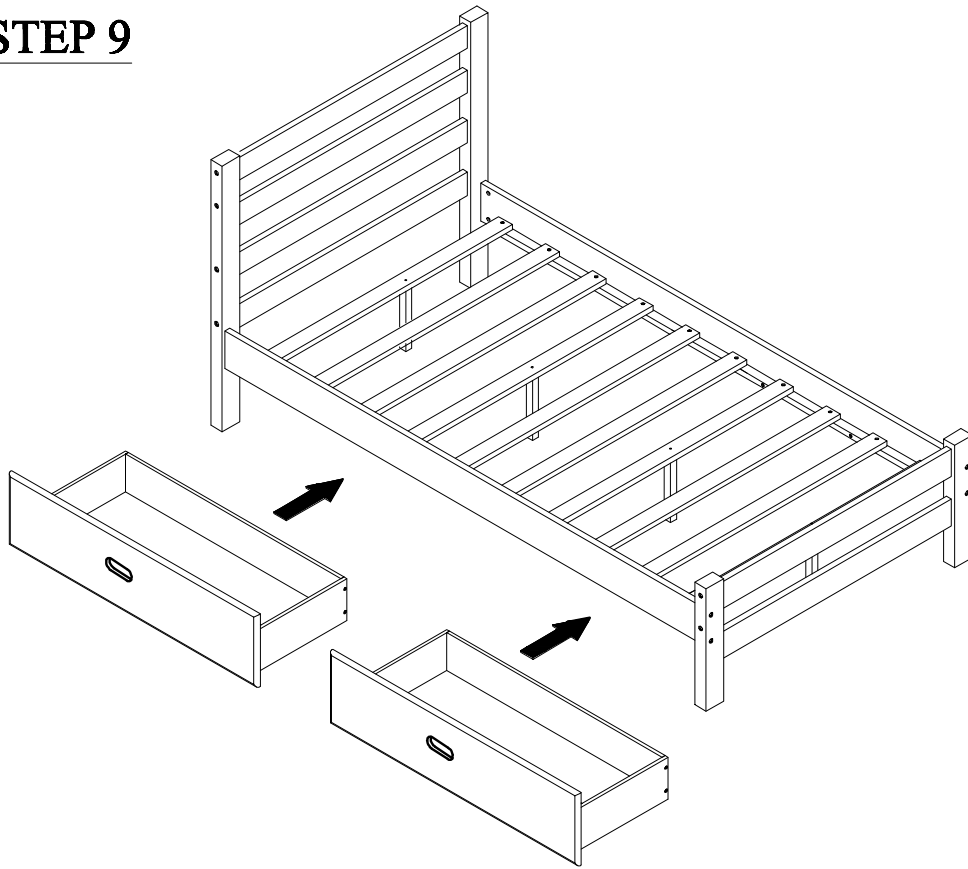

STEP 10

