

WARRANTY

We strive to offer high-quality products, and we also try our best to satisfy each and every customer that orders from us with product or service as needed. We provide 30 days warranty starting from the time you receive the item. Each customer must provide a record of their order such as the order number, or item receipt for any items that are out of the warranty period you may also still receive replacement parts by purchasing them with our company if they are available.

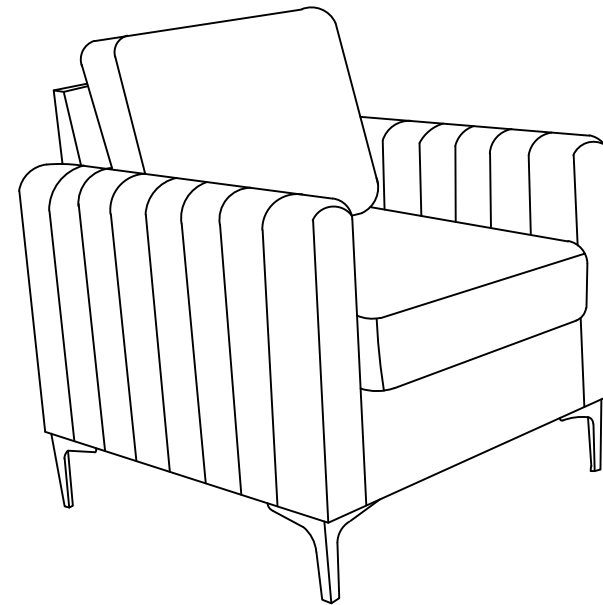

NOTE:

This brochure contains IMPORTANT safety info. Please read and keep for future reference.

MAINTAINANCE AND WARNING

- Keep furniture away from heat.
- Do not clean furniture with harsh cleansers or polish. Do not use detergents, Solvents, abrasives, spray packs or leather cleaner. Use non-color mild soap with warm water clean spills(Mix 1:10 soap to water)
- Do not place furniture under direct sunlight, material will possibly fade over time.
- Do not use on site dry Cleaning machine.
- Children should not climb or jump on the furniture.
- Do not write on furniture without a padded barrier to protect the surface.
- Not for commercial use, For residential use only.



Weight Limitation
250LBS

PARTS LIST

A*1

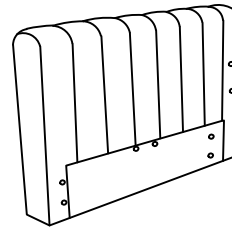

Right Arm

B*1

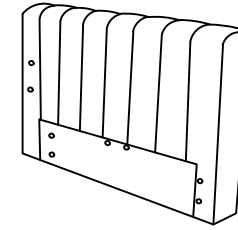

Left Arm

C*1

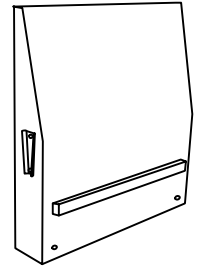

Backrest

D*1

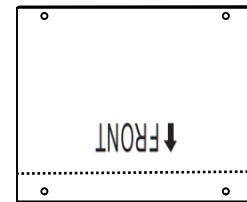

Baseplate

E*1

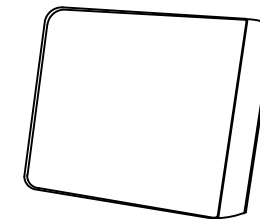

Backrest cushion

F*1

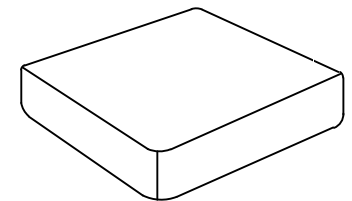

seat cushion

G*1



Front rail

H*1

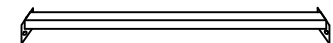

Metal bar

HARDWARE LIST

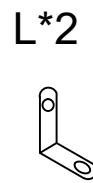
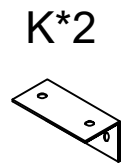
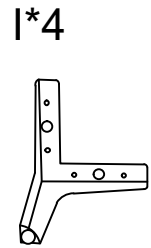
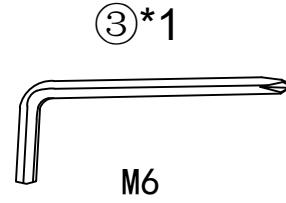
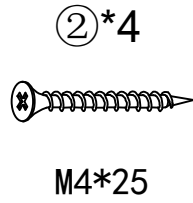
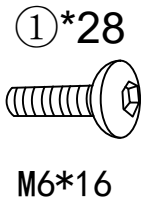

SPARE

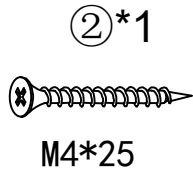
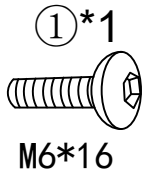

Be sure to check all packing material carefully for small parts which may have come loose inside the carton during shipment.

STEP1

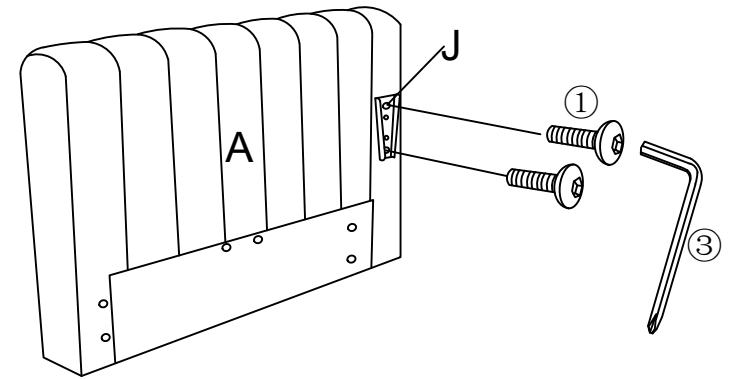
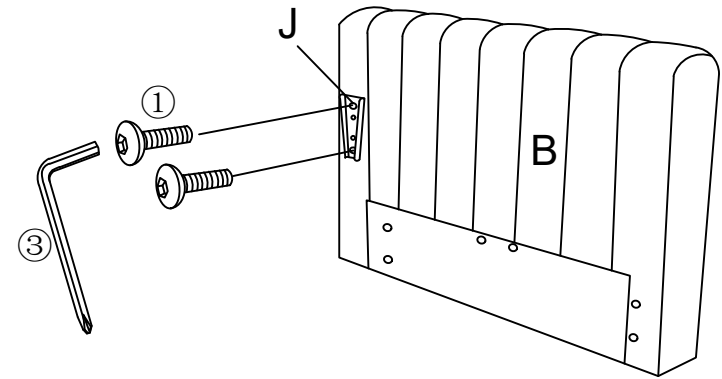

STEP1: Use bolt ①, allen key ③ to Attach the metal bracket I to inside of armrest (A/B). Make sure the holes aligned properly then fasten all bolts to secure.

STEP2

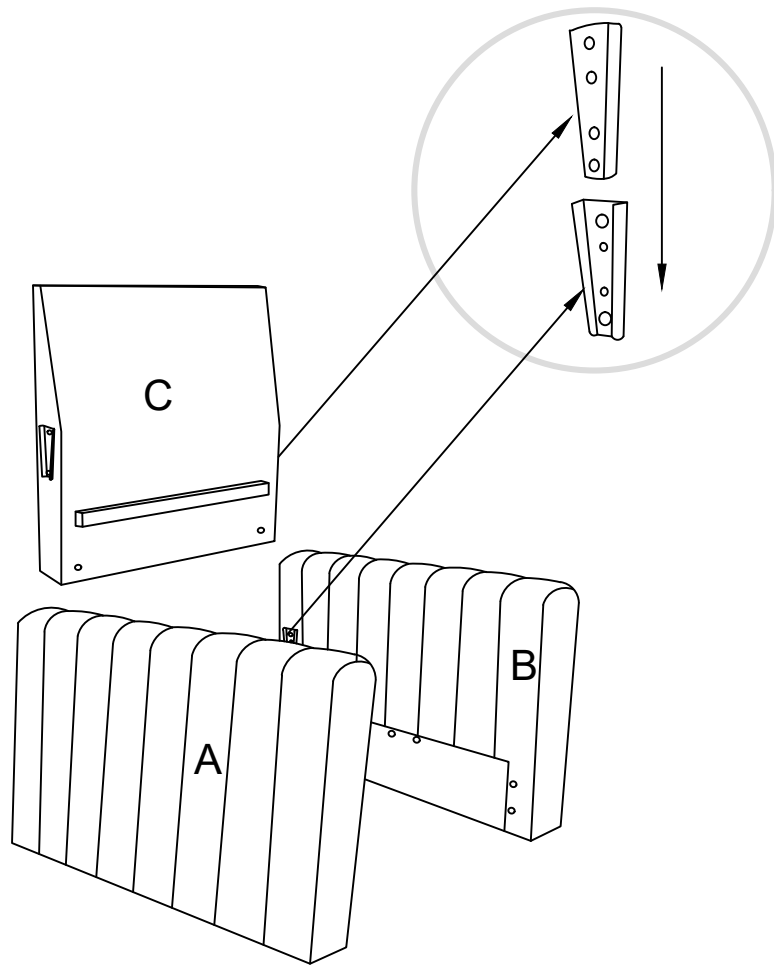

STEP2: With help of adult partner, carefully align the male and female metal bracket then push the backrest(C) all the way down in order to secure it to inside of armrest A/B.

STEP3

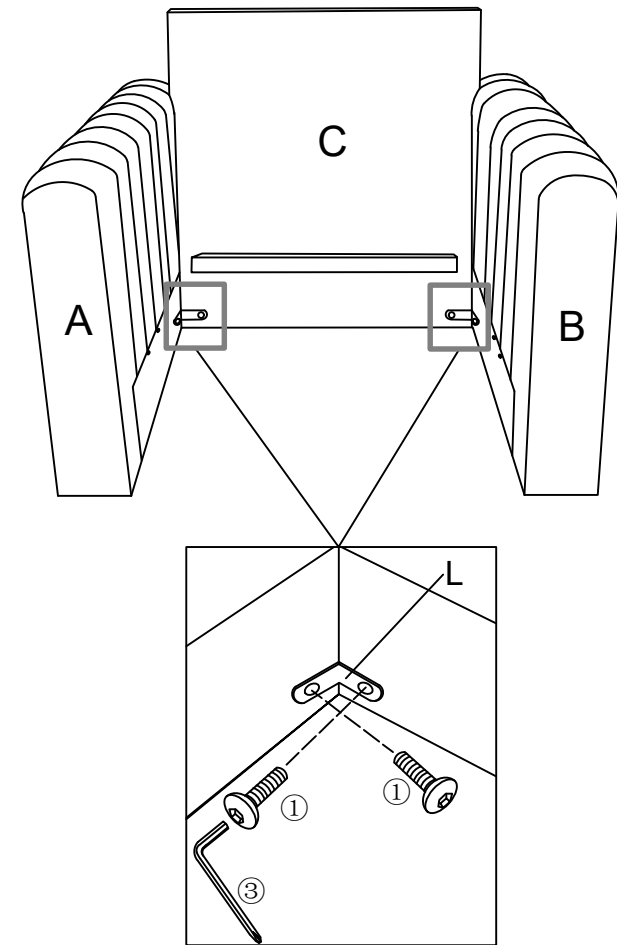

STEP3: Use bolt ①, allen key ③, bracket L to connect armrest A/B with backrest C. Please don't fasten any bolt until end of step 5.

STEP4

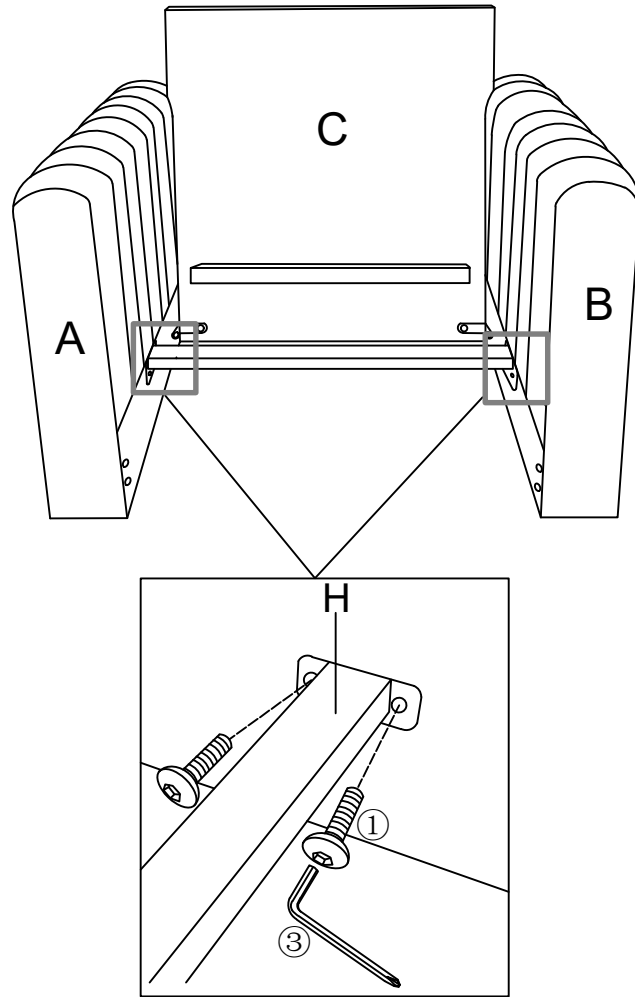

STEP4:Use bolt ① to connect metal bar H with armrest A/ B, make sure the metal bar set leveled .Please don't fasten any bolt until end of step5.

STEP5

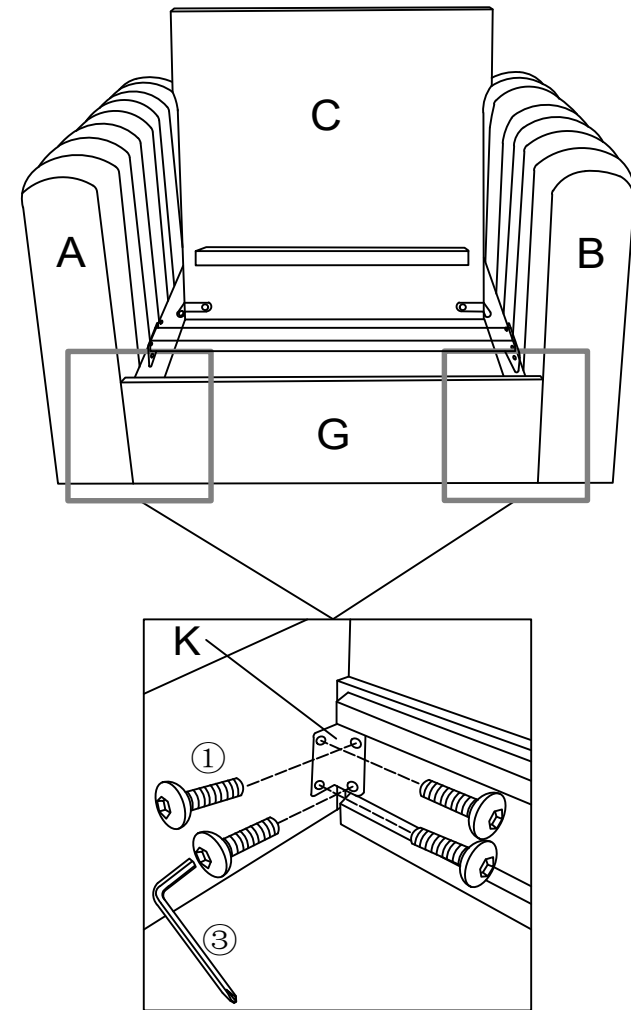

STEP5:Use bolt ①, allen key ③, bracket K to connect armrest A/B with front rail G, make sure armrest A/B, backrest C and front rail G aligned then fasten all bolts to secure.

STEP6

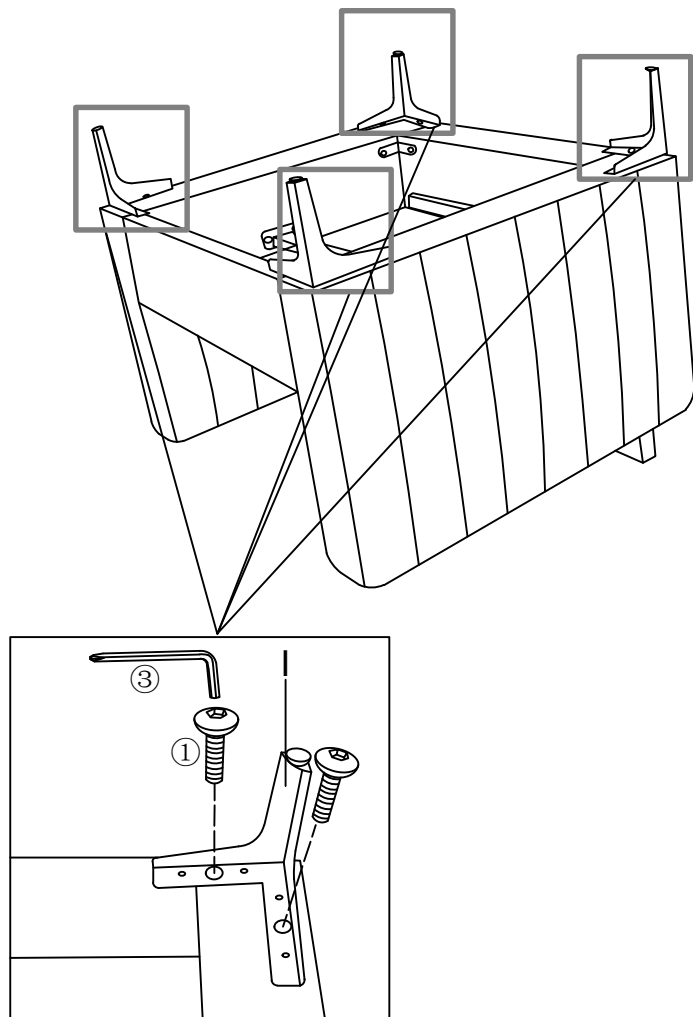

STEP6: Use bolt ①, allen key ③ to attach legs I to bottom of the armrest A/B, fasten bolts to secure.

STEP7

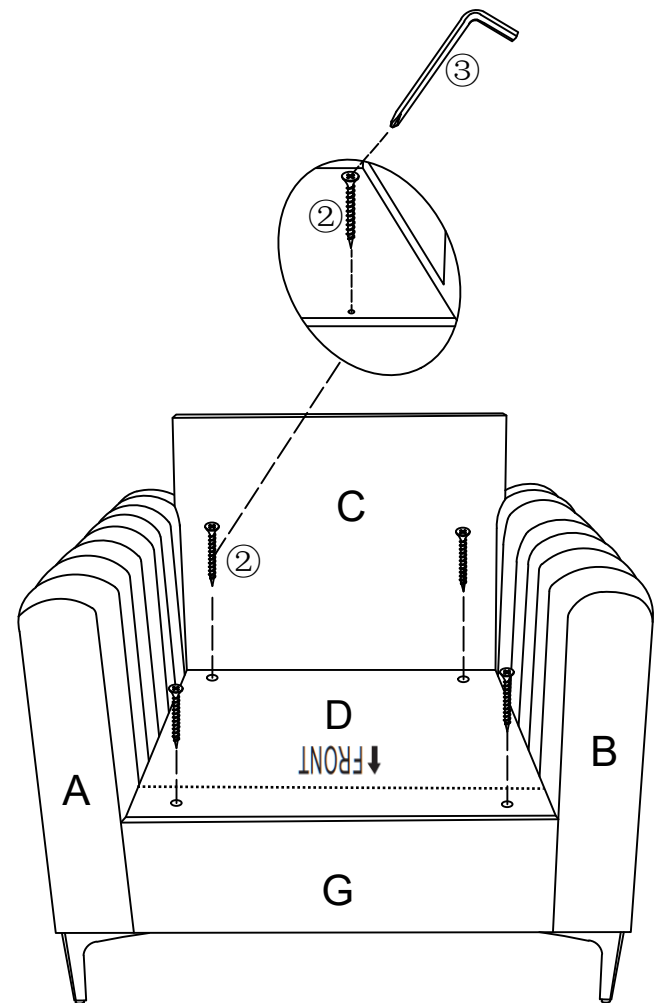

STEP7: Use philips head screwdriver ③ and screw ② to attach seat panel D to front rail G and backrest C, fasten to secure.

STEP8



Iron the fabric cover to stretch the wrinkles with steam iron while necessary. Please wait 48 hours for the compressed foam or polyester pillow filler to spring back after unbox all components. Hair dryer blow or hand slap on cushions will speed up the process.

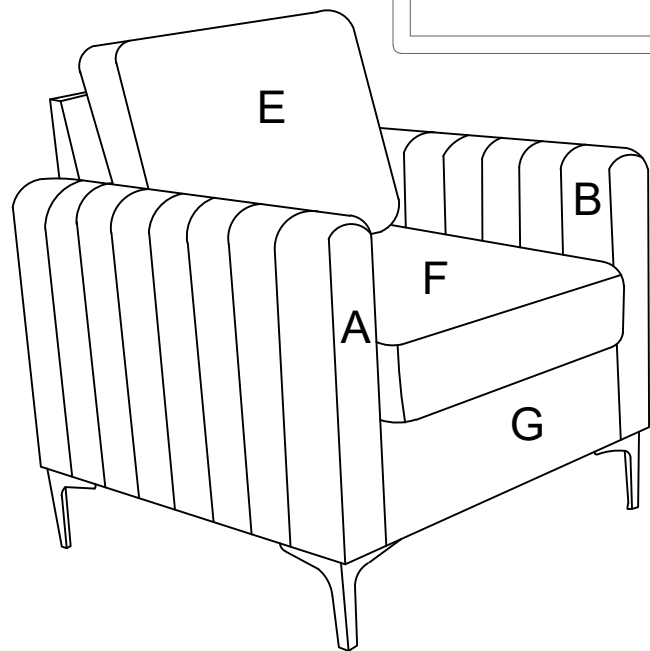

STEP8:Put the seat cushion F on the seat panel D.
Put the barkrest cushion E on top of the seat cushion F.

STEP9

