

ASSEMBLY INSTRUCTIONS & PARTS IDENTIFICATION

ORCHARD PARK SLAT BACK COUNTER STOOL

Thank you for purchasing this quality product. Be sure to check all packing material carefully for small parts that may have come loose inside the carton during shipment.

Hardware kit			
No	Description		Q'Ty
A		Hexa Nut Ø8	4 pcs
B		Lock Washer Ø8	11 pcs
C		Flat Washer Ø8	11 pcs
D		Long Bolt Ø6 x 80mm	4 pcs
E		Short Bolt Ø6 x 40mm	3 pcs
F		Allen Key	1 pc
G		Key Wrench	1 pc
H		Screw Ø64 x 35mm	6 pcs

Key Parts			
No	Code	Description	Q'ty
1	1771-BS420KDP40	Chair Back	1 pc
2	1771-BS420KDP41	Complete Seat	1 pc
3	1771-BS420KDP42	Right Facing Front Leg	1 pc
4	1771-BS420KDP43	Left Facing Front Leg	1 pc
5	1771-BS420KDP44	Right Facing Side Stretcher	1 pc
6	1771-BS420KDP45	Left Facing Side Stretcher	1 pc
7	1771-BS420KDP49	Front Stretcher	1 pc
8	1771P01F	Floor glide	4 pcs

STEP 1

- Carefully lay Chair Back flat on a smooth flat surface to prevent scratches.
- Attach Complete Seat to Chair Back by inserting a Flat Washer (C), Lock Washer (B) with Short Bolt (E) into each of the hole on the back rail of the seat, and Long Bolt (D), a Flat Washer (C) and Lock Washer (B) into each of 2 holes in the Complete Seat corners. (See Detail A & B).
- Tighten screws with provided Allen Key (F) by turning clockwise until secure

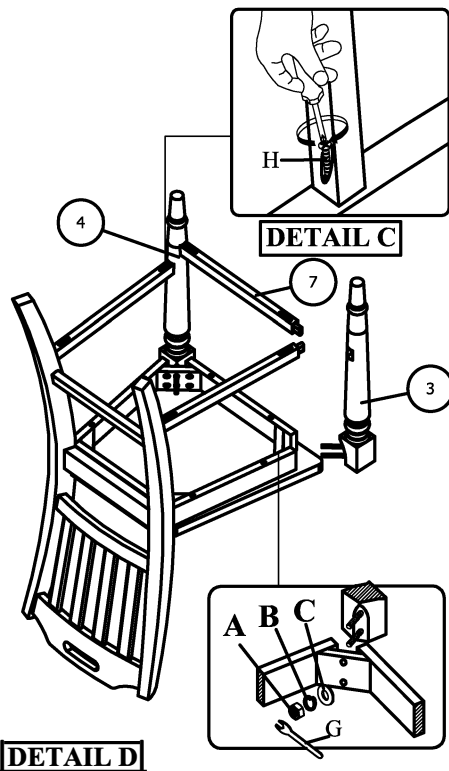
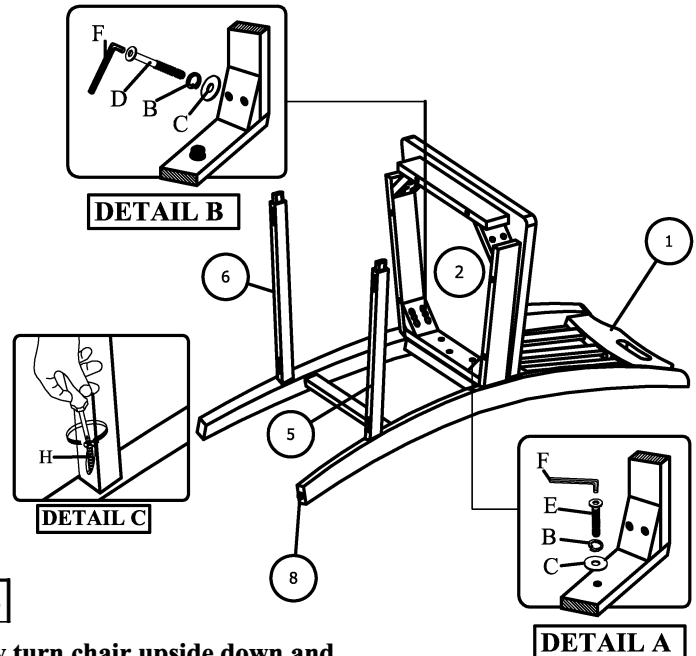

STEP 2

- Carefully turn chair upside down and insert the right stretcher into the back right leg, then position the right front leg into the front corner block and connect the stretcher to the front leg.
- Insert the left stretcher and right stretcher into the back left leg and back right leg, then position the front leg into the corner block and connect the stretcher to the front leg. (See Detail C)
- Insert the front stretcher between the two front legs. (See Detail C)
- Place Flat Washer (C), Lock Washer (B) and Nut (A) on each bolt, and hand tighten at this point
- Fasten stretchers with Wood Screws (H) by hand using a Phillips screwdriver (not provided) (See Detail C)
- Tighten all nuts by using Key Wrench (G)
- Be sure to tighten all screws and nuts prior to using Chair.

