

MACHRUS
UPPERBOUNCE®

Easy Assemble/Disassemble Trampoline User Manual

Assembly, Installation, Care, Maintenance and Use Instructions.

WARNING: Read these materials prior to assembling and using this trampoline.

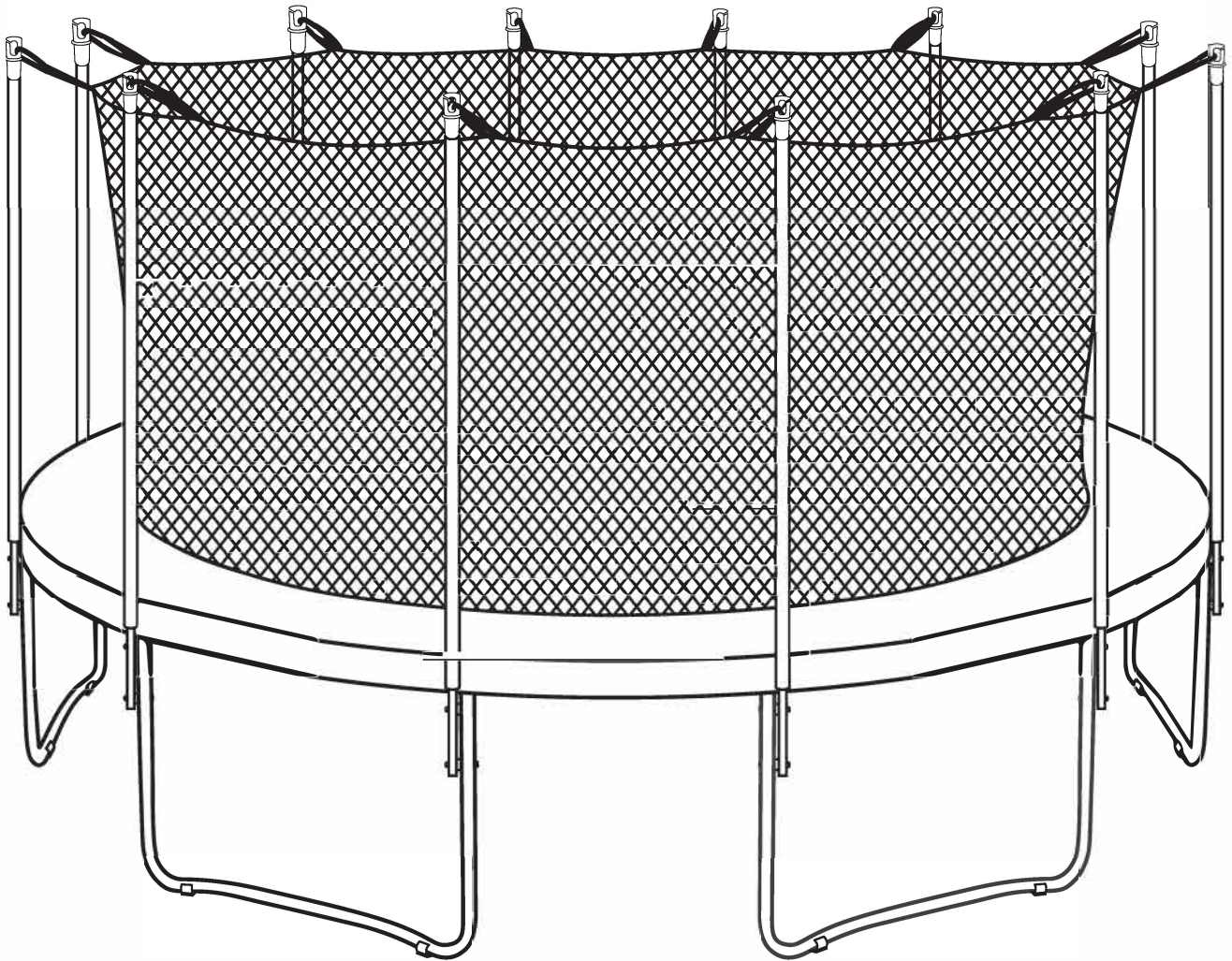

Models

UBSF01-7.5	UBSF01-10	UBSF01-12	UBSF01-14
UBSF01-15	UBSF01-16	UB03EC-09E	UB03EC-15E

MACHRUS

UPPERBOUNCE®

USA

UK



Call us

1-845-810-0083

020-3150-0484



Email us

support@machrus.com

support@machrus.co.uk



Check out our website

www.MACHRUS.com

Thanks for purchasing this Machrus trampoline

Simply follow the assembly and safety instructions in this manual and you will soon be starting your **Machrus** exercise program for a happier, healthier lifestyle and fun!

MONDAY - THURSDAY
9:30 A.M. - 5:00 P.M.
Eastern Time.

FRIDAY
9:00 A.M. - 12:00 P.M.
Eastern Time.

TABLE OF CONTENTS

	Page
Introduction, Guidelines, Additional Tips, Warnings	3-7
Trampoline Frame Parts List	8
Overall Parts with Item Code	9
Trampoline Frame Assemble	10-11
Trampoline Mat Assembly	12
Trampoline Pad Assemble	13
Enclosure Set Parts List	14
Enclosure Set Assemble	15-16
Enclosure Set Disassembly	17
Testing the Trampoline	18
Fundamental Bounce Techniques	19
Replacement Parts List	20

1. General Instructions

1.1 Purpose

- The product is intended for home/domestic use only and is not suitable for professional or medical uses.
- The maximum weight is 220-330 lbs. based on size of trampoline ordered. Overloading the trampoline above the recommended user weight will cause damage to the trampoline which is not covered by warranty.

1.2 Danger for children

- Do not let unsupervised children near this product. Carry out the necessary safety precautions and supervise all trampoline activities. Be aware that the packaging material is not suitable for children. There is a danger of suffocation!
- Trampolines over 51 cm (20 inches) in height are not recommended for children under 5 years of age. Children do not recognize potential dangers of this product. Keep children away from this product, it is not a toy. The product has to be stored out of reach of children and pets.

1.3 Attention - Product Damages

- Do not alter the product. Only use original spare parts. Repairs should only be carried out by qualified technicians. Improper repairs can compromise the safety of your trampoline. Use this product only as described in this manual.
- Protect the product against humidity and high temperatures.

1.4 Advice for the assembly

- The assembly of the product must be done carefully by at least two able-bodied adults. If in any doubt, ask a technically qualified person.
- Before you start assembling the trampoline, read all the instructions in this manual.
- Remove all packaging materials and lay down all parts on a free space. This gives you an overview and simplifies the assembly procedure.
- Check with the parts list that no parts are missing. Dispose of the packaging material when the assembly is completed.
- Beware that when using tools or doing technical work, there is always a risk of injury. therefore assemble the product carefully.
- Create a danger free environment, for example: Do not leave tools scattered around the workspace.
- Store the packaging material in a way that cannot cause any danger. Foils and plastic bags are dangerous for children (danger of suffocation)!

- After installing the product according to the instruction manual, please make sure that all screws, bolts and nuts are correctly installed and tightened and that all joints are tightly fixed.
- A clearance space of at least 24 ft is necessary above the trampoline. An appropriated clearance must be kept between the trampoline and possible sources of danger, such as electric cables, tree branches, playing devices, swimming pools and fences.
- The trampoline must be set up properly before use.
- Never set up the trampoline in rainy, windy or stormy conditions, especially lightening conditions. It is recommended that the trampoline be taken apart and stored in bad weather.
- The metal frame of the trampoline will conduct electricity. Lighting, extension cords and all electrical equipment must never be allowed to come in contact with the trampoline.
- The trampoline must always be used in a well-lit area.
- Do not place any objects under the trampoline.
- The trampoline must not be used in the vicinity of other leisure devices and constructions.
- When assembling or disassembling, please use gloves to protect your hands.

Additional tips:

- For additional stability you can place sand bags on the trampoline legs. This will prevent the trampoline from tipping over in the event of any sideward force.
- Do not use during pregnancy.
- Do not use when suffering from high blood pressure.
- Do not wear shoes while jumping. This will damage the jumping mat which is not covered by the warranty.
- No smoking.
- Do not put cigarettes, pets, sharp objects or any other foreign objects on the trampoline.
- Do not use the trampoline when under the influence of alcohol or drugs.
- Do not sit or lean on the cover pad as it needs to be flexible so it can move with the jumping mat. Please do not allow small children to pull themselves up onto the trampoline by using the cover pads. Tears in stitching caused by obstructing frame pads are not covered by warranty.
- Place trampoline on level ground. Preferably on grass. Locating the trampoline on a hard surface will add stress to the frame and over time cause damage which is not covered by the warranty. Placing the trampoline on uneven surfaces may result in the trampoline tipping over.
- Do not expose the trampoline to direct contact with open flames.
- Secure the trampoline against unauthorized use.
- Do not use if trampoline is wet.
- Trampoline should be tied down with anchors during windy conditions or disassembled and stored away.

WARNING:











1. Please ensure that the safety enclosure net zipper is 100% closed and all three entrance hooks are re-hooked before jumping.
2. Do not intentionally jump into the safety net, it is only designed to stop persons from falling off the trampoline. Intentional jumping into the safety net may cause the trampoline to topple over, or may damage your net. Abuse of the safety net is considered negligent use which is not covered by the warranty, please refer to the disclaimer.

2. Safety Instructions for Trampolines

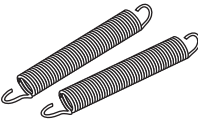
- All users of the trampoline need a supervisor. Regardless of the age or experience of the user.
- The safety instructions of the trampoline should always be considered and obeyed.
- Somersaults should be avoided. Incorrect landings on the trampoline can lead to injuries, particularly to the back, neck or head. Injuries may include paralysis, or even death.
- Only one person should use the trampoline at a time. Multiple users on the trampoline will increase the risk of collision.
- The trampoline has to be examined for damage, wear or defective parts before each usage, as they can impair the overall safety of the trampoline. The damaged, worn or defective parts should be replaced immediately. In the meantime the trampoline must be restricted from access.
- No clothes with hooks or parts may be carried when jumping on the trampoline, in order to avoid hooks getting caught.
- The trampoline must be set up only on a flat ground and non-slippery surfaces.
- Strong winds can blow the trampoline away. If strong winds are predicted, the trampoline must be moved to a protected place and taken apart, or fastened to the ground with cords and moorings.
- Try to avoid moving the assembled trampoline, it could bend during transportation. Should it be necessary to move the trampoline, please consider the following: at least four people must be evenly spaced around the frame to lift the trampoline off the ground. The trampoline must be carried horizontally, and if the frame shifts position use four people to draw the trampoline into shape.
- Trampolines are jumping devices, enabling the user to jump to unusual heights as well as into a multiplicity of body movements. Jumping into the trampoline, hitting the frame, cover pads, and landing incorrectly on the trampoline; can lead to injury.

- Users should be familiar with the user manual. This manual contains assembly instructions and selected precautionary measures as well as recommendations for servicing and maintenance of the trampoline, in order to ensure a secured and fun use of the trampoline.
- It is the responsibility of the owner or the supervisor to guarantee that all users of the trampoline are informed about all safety rules and that there is sufficient space around the trampoline as a safety precaution.
- Never place the trampoline near water, and keep sufficient space around it as a safety precaution.
- Beware of moving parts which could catch your arms and legs.
- Do not stick any foreign objects into the trampoline.
- Do not allow anyone or any object to go under the trampoline while someone is jumping on the mat. The jumping mat is flexible and the downward force created by someone jumping can cause serious injuries.
- Implement all safety rules and make yourself familiar with the information in the user manual.
- The trampoline can only be used if the jumping mat is clean and dry. Worn or damaged jumping mats should immediately be replaced.
- Objects that could be dangerous should be vacated from the area.
- Avoid unsupervised use of the trampoline.
- Do not use the trampoline under influence of alcohol or drugs (incl. medication).
- Learn the fundamental jumping techniques thoroughly. Before trying difficult jumps, see section fundamental bounce techniques.
- Carefully climb onto trampoline. Do not jump into it directly. Do not use the trampoline as a jump board for other articles.
- For further information or exercise instructions, you can turn to a trained trampoline teacher.

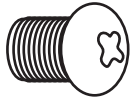
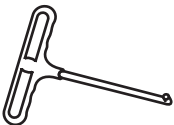
TRAMPOLINE FRAME PARTS LIST

ITEM	PART IMAGE	MODEL	7.5 FT	9 FT	10 FT	12 FT	13 FT	14 FT	15 FT	16 FT
A		Frame Cover	1	1	1	1	1	1	1	1
B		Jumping Mat	1	1	1	1	1	1	1	1
C1		Top Rail	3	3	4	6	6	6	6	6
C2			3	3	4	6	6	6	6	6
D		Springs	42	54	64	72	84	96	84	108
									UB03EC-15E	
									96	
F1		Leg Extensions	0	0	0	6	6	6	6	6
F2			6	6	8	6	6	6	6	6
G		W-Shaped Leg	3	3	4	6	6	6	6	6
H		Screws	18	18	24	36	36	36	36	36
I		Spring Tool	1	1	1	1	1	1	1	1
J		Screw Driver	1	1	1	1	1	1	1	1
K		Leg Stabilizer	6	6	8	12	12	12	12	12

OVERALL PARTS WITH ITEM CODE

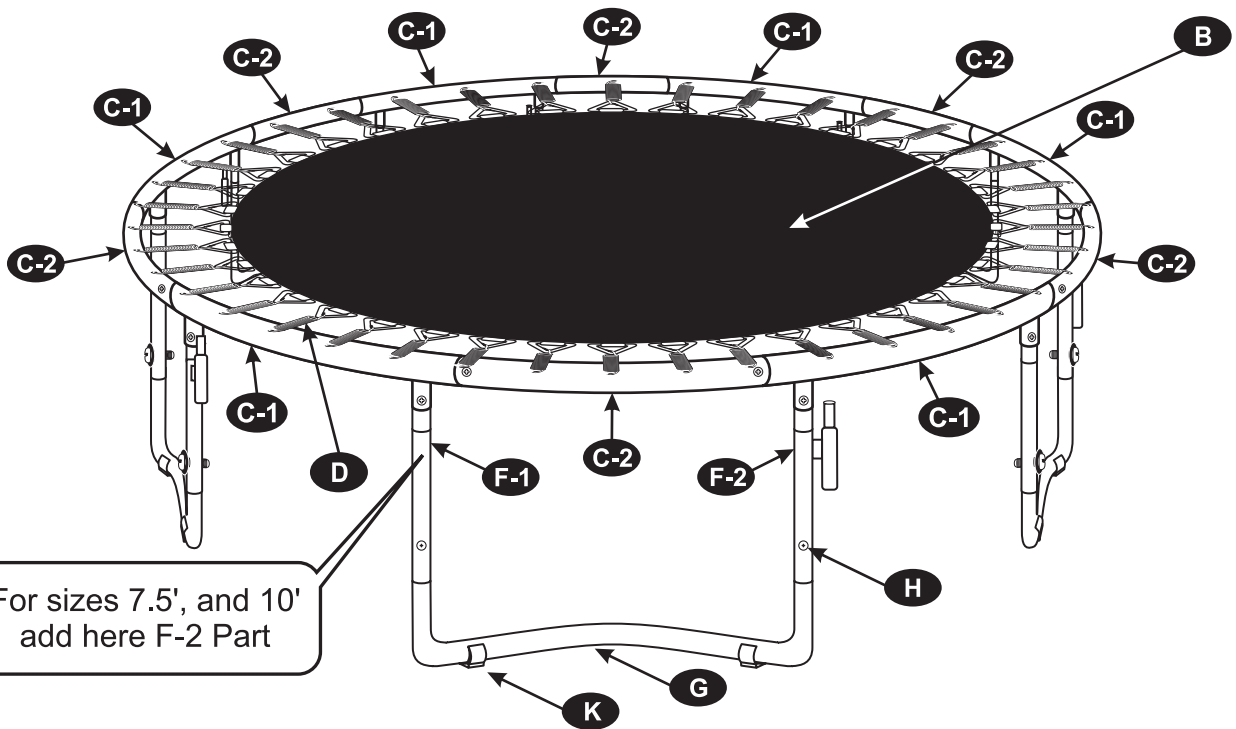
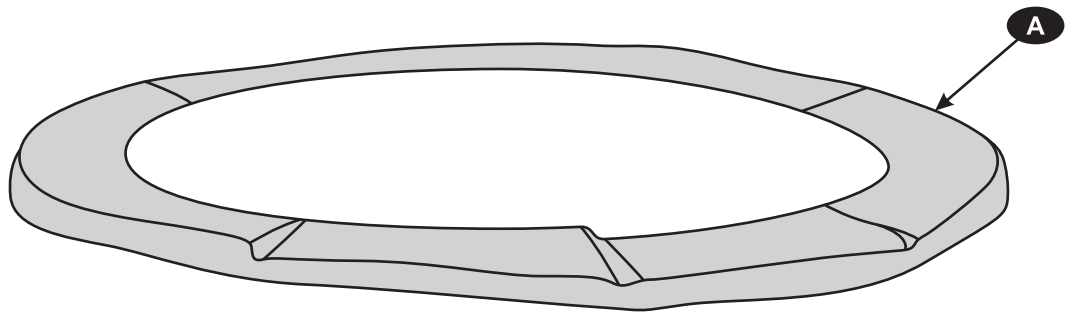
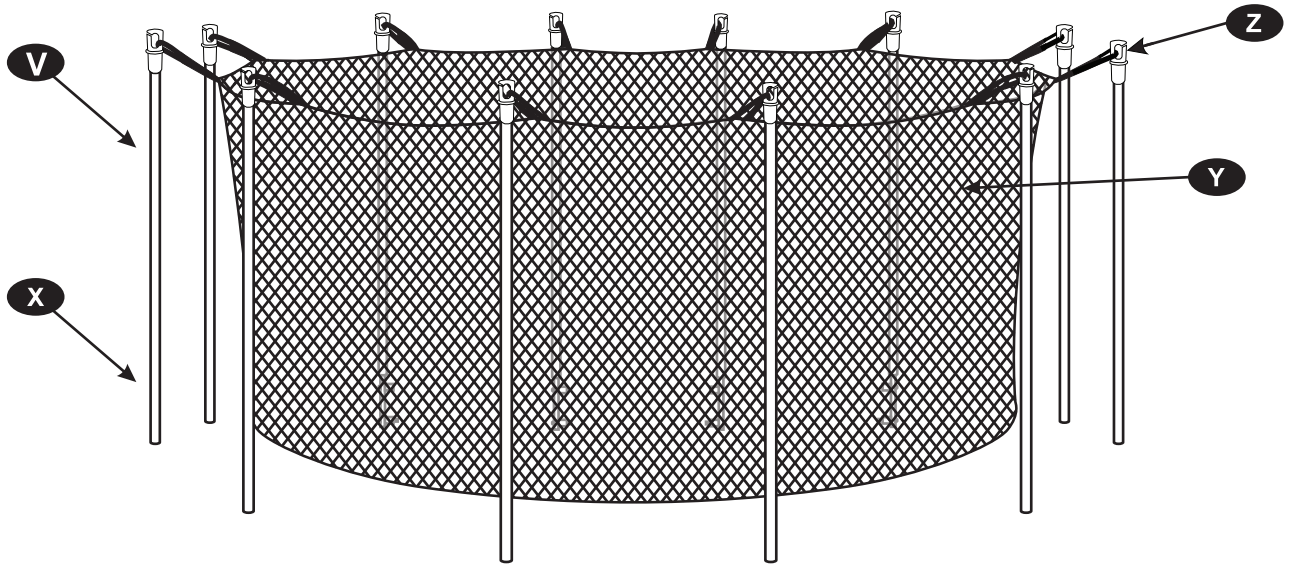

Note! This diagram is only for your reference. All Sizes have different quantity for specific parts, please refer to Parts list page for exact components per size.

TRAMPOLINE FRAME ASSEMBLY

Warning :

2 adults in good physical condition are required for the following assembly. Wear proper shoes and maintain balance to prevent a fall. Failure to follow all instructions and warnings exactly may result in serious injury.

Step 1- Frame Layout

Lay out the trampoline parts on the ground so that you start to form a circle with the top rail sections. Make sure to keep all the tubes in the same direction all around the trampoline frame.

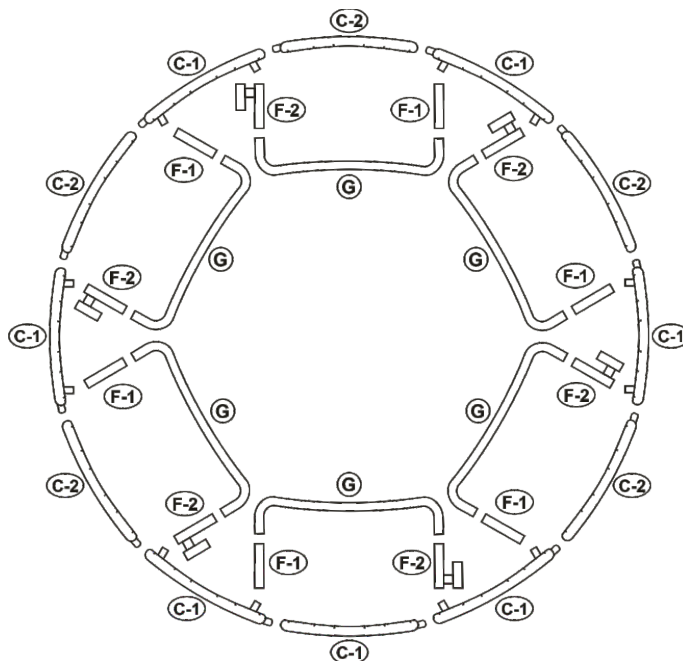

Step 2- Assemble The Rail with the Legs

Assemble each of the Leg base to the Leg Extension. Attach the leg extensions to the leg base and tightly secure together with the screws. one F- 1 and one F-2 to part G, (note: 7.5 and 10 ft. only has F-2 so you attach to both sides F2). Repeat this step for all legs.

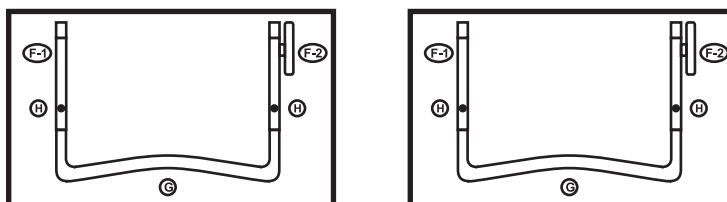

Step 3

Connect one C-1 and one C-2 together then continue the following pattern: 'C-1' + 'C-2' + 'C-1' + 'C-2' continue until you form a large circle. Joining the last bar may require two or more adults in good physical condition. With a second person holding the opposite end, bring both sides of circle together and have them secured.

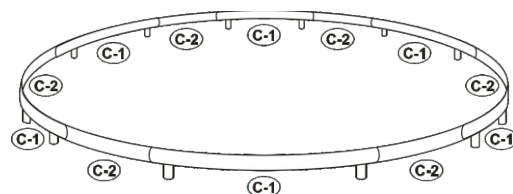

Note:

If your frame does not seem sturdy this should not worry you, for the trampoline mat will tighten it up.

Step 4 - Connect the legs bases to the top rail circle.

Attach the leg supports you assembled in step 2 to the top rails C-2 part like the picture shown. Repeat this step until you have the full frame standing.

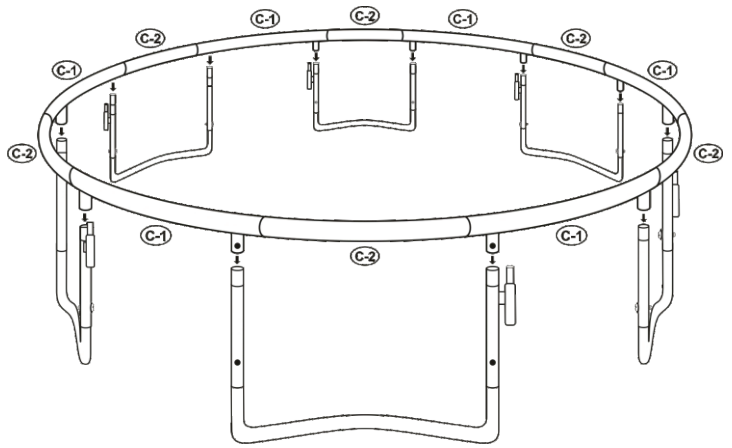

Step-5

Tightly Secure, the leg supports to the top rail frame with screws.

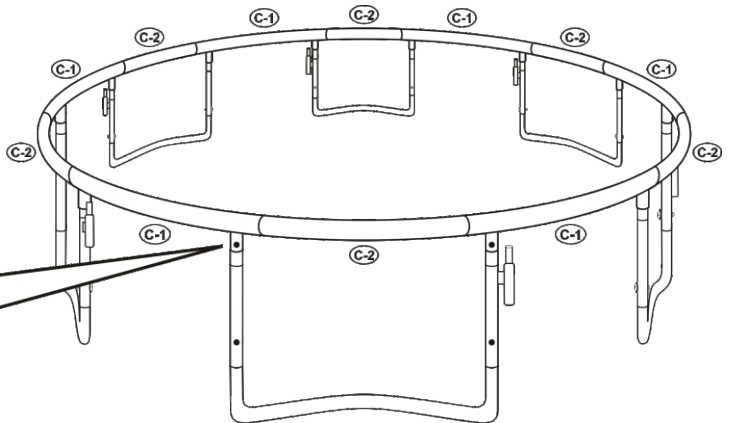
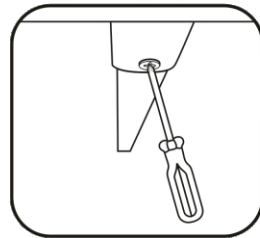

Step-6

Secure together with screws underneath the C-2 parts to hold together the top rail.

Note:
If you are unable to screw it together because the holes are not aligned please wait after installing the mat, it will stabilize then.

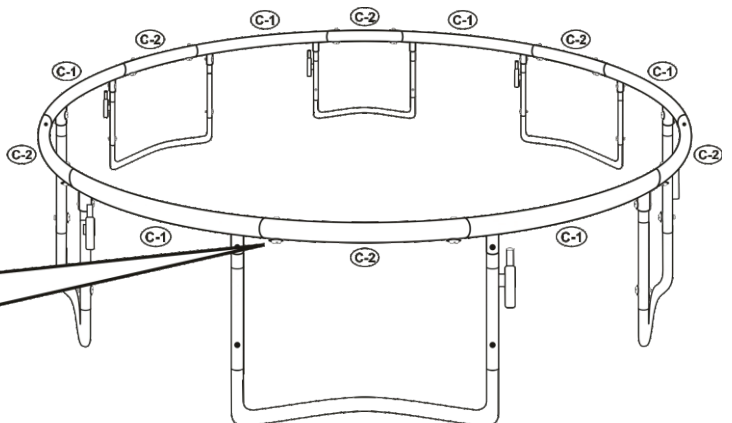
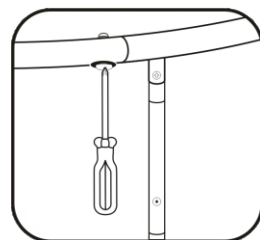

Add stabilizer Part K to bottom of the legs, 1 for each side of leg.

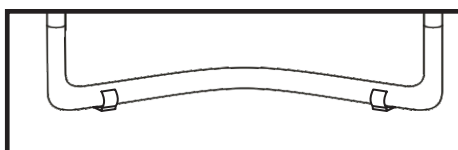

Now, the frame assembly is complete.

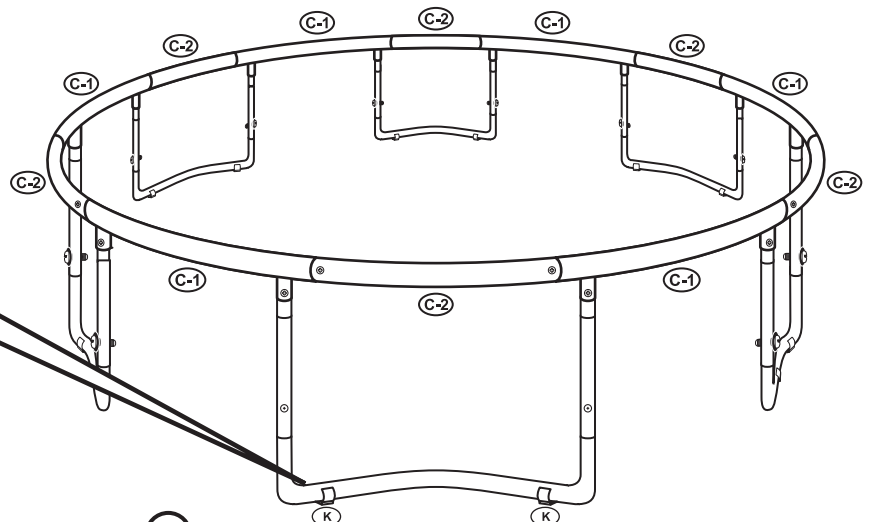

STEP 7 - Trampoline Mat Assembly

Warning: Be careful where you place your hands during spring assembly as connector points can pinch!

1. Lay out the Trampoline Mat inside the frame.

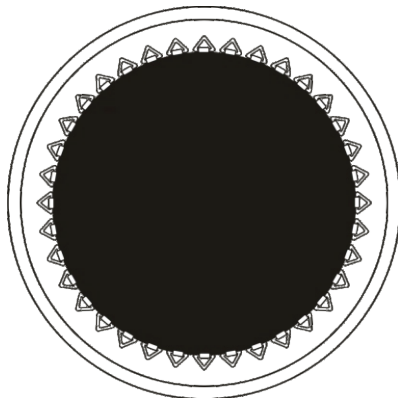

2. Connect 4 springs to top rail 1/4 circle apart from each other as figure below.

Note:

Make sure the difference from 1 spring to the other should be the same as the holes of the frame.

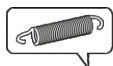
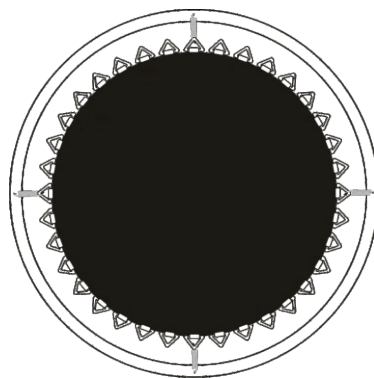

1

2

3

4

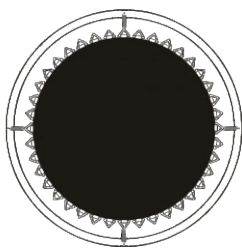

First connect the 4 springs 1/4 circle apart from each other

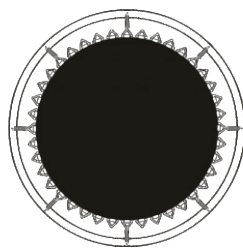

Connect all middle springs as figure

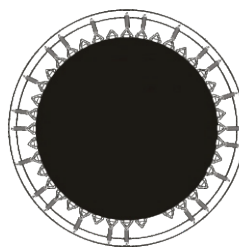

Then continue, connecting every few springs

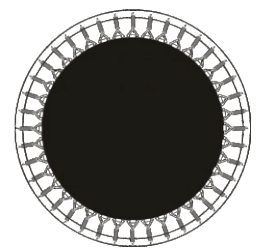

Complete the rest of the springs

How to Use the Spring Pulling Tool

Step I: Hook the more rounded end of the spring onto the Trampoline mat's triangular rings.

Step II: Extend the spring pull tool and link it up with the other end of the spring. Pull the tool in the direction of the trampoline frame until the spring head is lined up with the hole in the trampoline frame. Slide the spring end into the hole as you remove the tool.

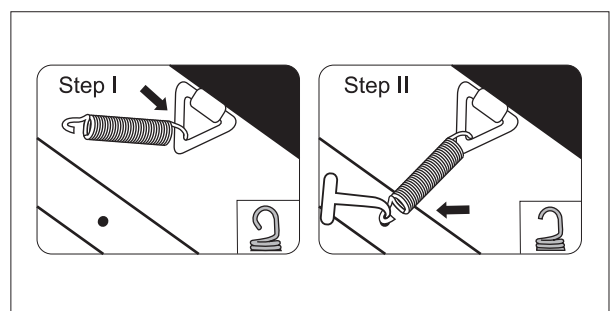

STEP 8 Cover Pads Assembly

1. Lay out the safety pad around the outer edge covering all the springs as shown on right.

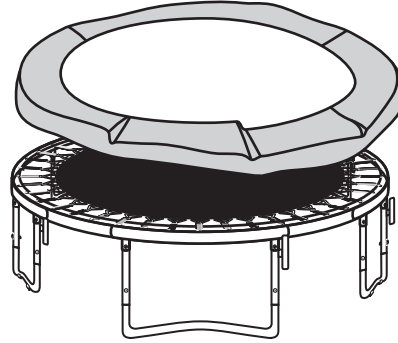

2. The safety pad has a few sets of strings with two S-shaped hooks at the end, all around the pad. Attach the S shaped hooks to the V-rings of the mat. Attach the hooks from underneath the pad. Refer to the figure at the side to see how to attach it correctly.

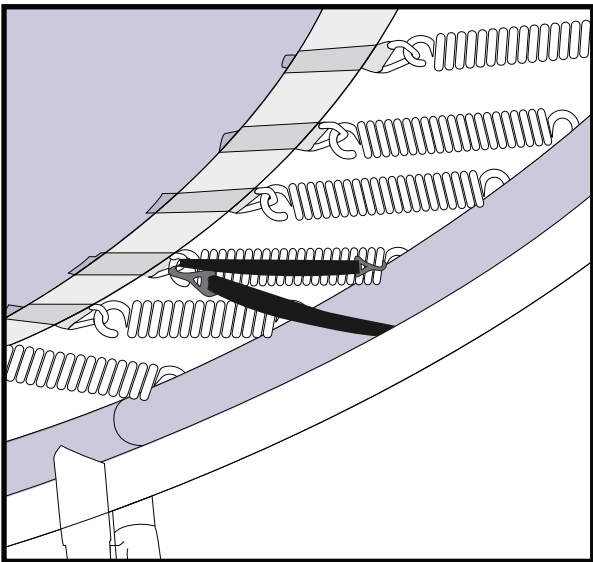

Note:

Model UB03EC-15E has single straps that must be tied to the trampoline frame by making a knot around the frame pole using the two ends of the strap. See the figure below for clarification.

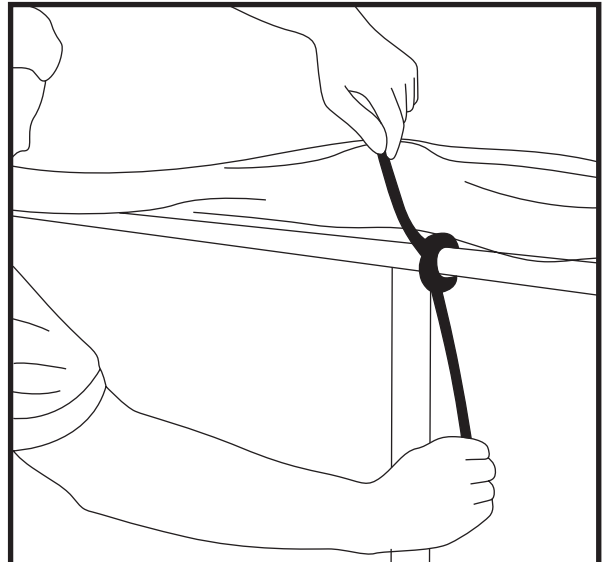



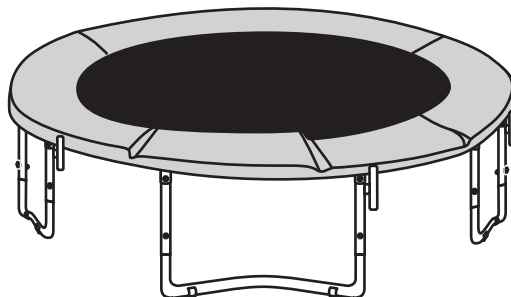

This is how your trampoline should look now

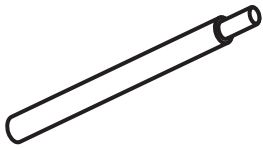
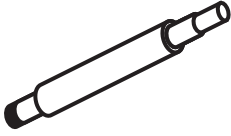
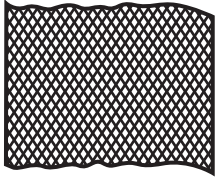

Please refer to next steps to install the enclosure Set.

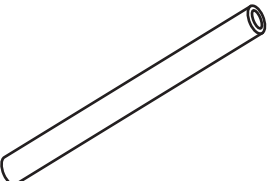
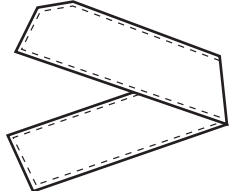
ENCLOSURE PARTS LIST

ITEM	PART IMAGE	MODEL	7.5 FT	9 FT	10 FT	12 FT	13 FT	14 FT	15 FT	16 FT
V		Upper Net Pole With Foam Sleeve	6	6	8	6	6	6	6	6
W		Lower Net Pole With Foam	6	6	8	6	6	6	6	6
X		Enclosure Net	1	1	1	1	1	1	1	1
Y		Pole Cap	6	6	8	6	6	6	6	6
Z		Rope	1	1	1	1	1	1	1	1
U		Foam Sleeve	6	6	8	6	6	6	6	6
T		Sleeve	6	6	8	6	6	6	6	6
S		Push button	12	12	16	12	12	12	12	12

ENCLOSURE POLE ASSEMBLY

Warning :

2 adults in good physical condition are required for the following assembly. Wear proper shoes and maintain balance to prevent a fall. Failure to follow all instructions and warnings exactly may result in serious injury.

Step-1 Insert the push button into part F2, the button should pop out through the hole. You can then attach the lower enclosure pole to the part F2.

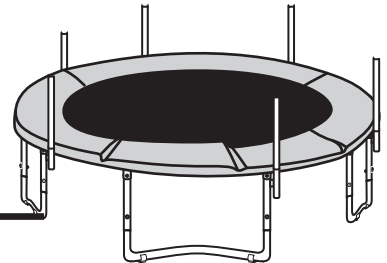

Note: For the lower pole use the poles that are tapered/narrow at both ends.

Step-2 Once the lower pole is attached to the part F2, insert the pushbutton on the opposite end of the lower pole, the button should pop out of the hole. You can then attach the upper pole to the lower pole. Continue this step to all the poles.

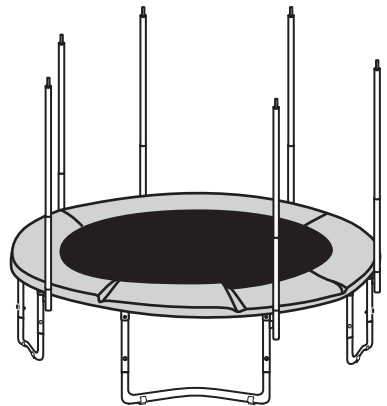

New Feature!

Step-3 The PVC sleeves should be used to cover all the poles. Once the upper and lower poles are connected to the trampoline frame, cover the poles with the PVC sleeves (Part T) as shown in the picture.

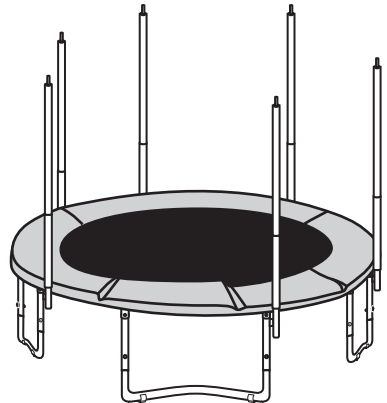

Step-4 After connecting all enclosure poles insert the Pole caps. Have all poles caps set in place on top of the trampoline poles.

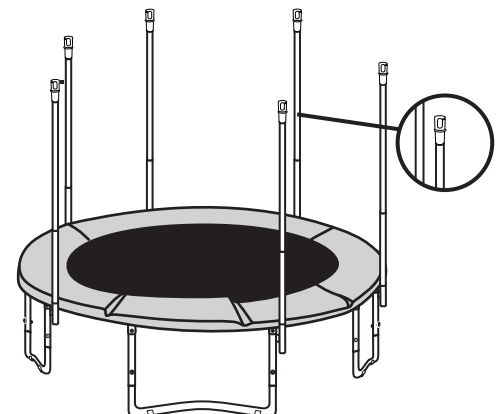

Step-5 Clip and adjust all buckles of the safety net to the "C" shaped part of the pole cap

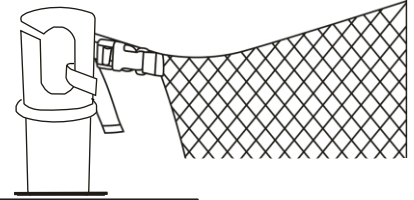

SECURING THE BOTTOM OF THE NET

1. Connect the net to the V-rings of the trampoline mat using the attached clips, securing at regular intervals. This holds the net in place for you to complete the attachment with rope.
2. Secure one end of the rope by knotting it to the V-ring closest on one side to the trampoline entrance zipper.
3. Weave the rope through the net and every second v-ring successively, moving around the trampoline in the direction away from the entrance zipper.
4. When you complete the weaving and reach the other side of the entrance zipper, secure the other end of the rope also by knotting it to the V-ring closest to the entrance on that side.

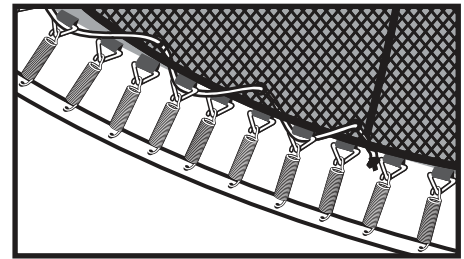
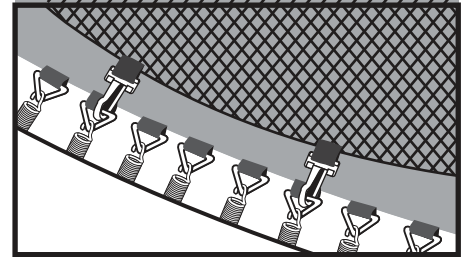

Your trampoline safety net is now fully secured. Follow the safety checks in the 'Testing the Trampoline' section before using the trampoline net.

Put warning label here

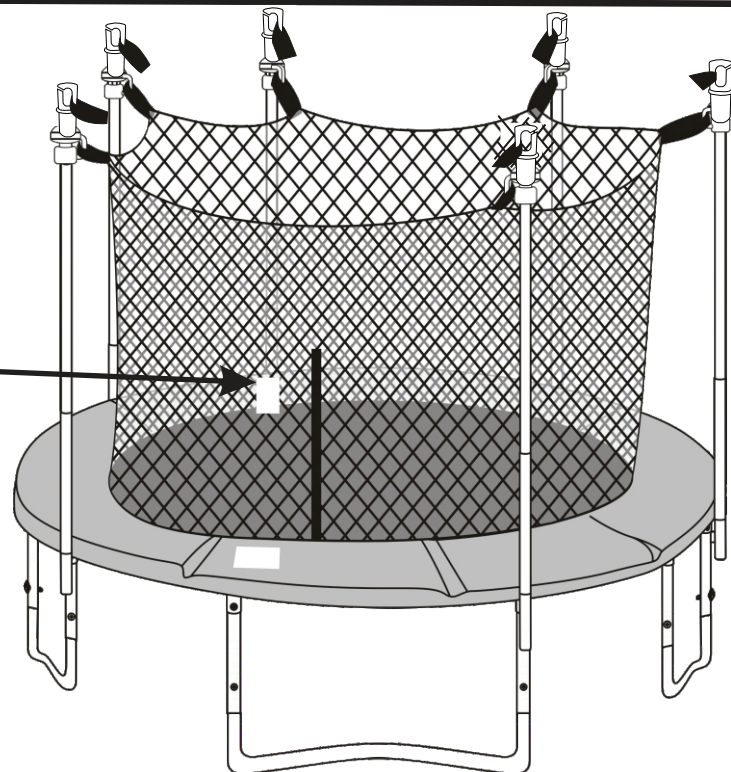

Your Upper Bounce Trampoline is now assembled and ready to be used.

Please attach the warning label included in the box to the enclosure net and safety pad. Make sure labels are placed at the trampoline entrance to avoid misuse of the trampoline

ENCLOSURE POLE DISASSEMBLY

The Upper Bounce Trampoline is specially designed to easily disassemble the Enclosure Set while its not in use for a longer period such as during the winter. Here you will find the instructions how to disassemble it. Please Note! That this instruct you only how to take apart the Enclosure Set and cover it with a weather cover (Not Included in the trampoline purchase).

1. Remove the bottom poles while its connected to the top poles Continue removing all the poles while being connected with the net and the upper poles.

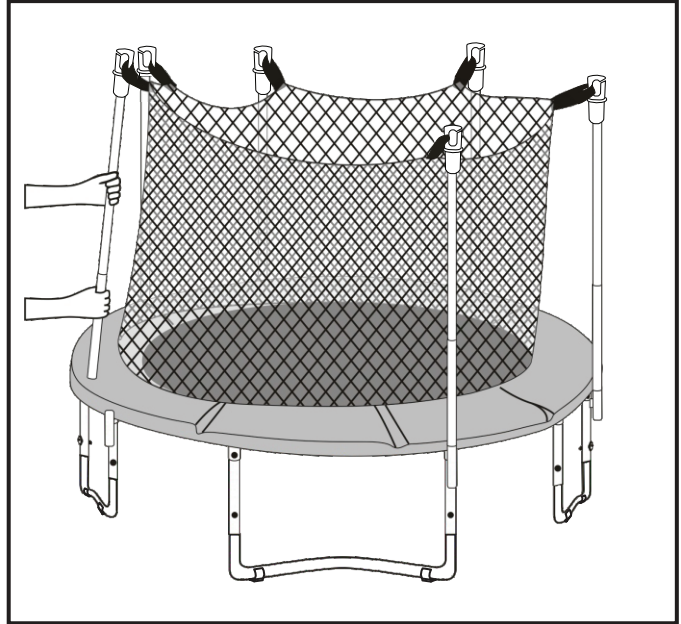

2. After removing lay it on the trampoline as shown in fig.

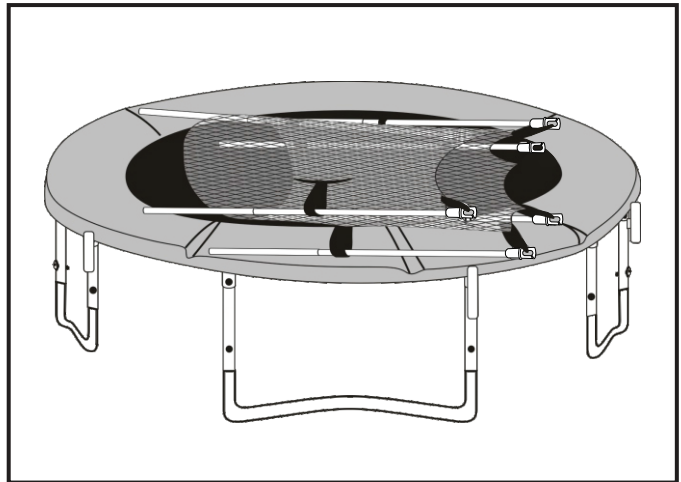

3. Now put the weather cover on the top of the trampoline. (This is not included in the purchase)



TESTING THE TRAMPOLINE

After assembling the trampoline, it is important that you perform the following safety checks:

Trampoline Safety Checks:

- Using a screw driver, check if all the screws are tightly secured.
- Look under the trampoline and check if all the springs are hooked securely to the frame and triangular rings.
- Move the trampoline around to check the sturdiness of the frame.
- Using your two hands, put your body weight on one section of the trampoline and release to ensure that the floor is even.
- Inspect the cover pads and check if they completely cover the springs and frame.
- Make sure the strings of the pads are tied securely.

Enclosure Net Safety Checks:

- Hold onto pole net jacket and check that all the enclosure poles are sturdy by shaking it.
- Inspect the enclosure net and pole jacket for any tearing in the stitching or material.
- Ensure that the enclosure net zipper and entrance hooks function properly.
- Check to see if all safety enclosure hook are attached to the triangular rings under the trampoline.

After the above checks are performed have one person test the trampoline by continuously jumping in the center for 5 minutes. If the trampoline feels sturdy, your trampoline passed the test! Congratulations.... you have completed the trampoline assembly! Remember to abide by all the safety rules. Have fun, play safe...

FUNDAMENTAL BOUNCE TECHNIQUES

All trampoline users are recommended to understand and perfect these fundamental bounces.

THE BASIC BOUNCE

- Start from a standing position, feet shoulder width apart with head and eyes on the mat.
- Swing your arms forward and up and around in a circular motion.
- Bring feet together while in mid-air and point toes downward.
- Keeping feet shoulder width apart when landing on mat.

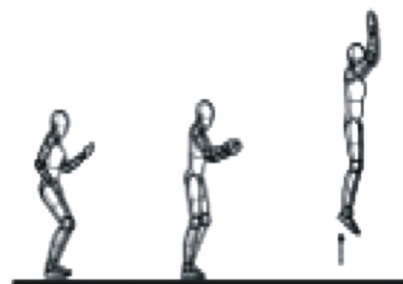

THE BREAKING MANEUVER

- Occasionally they may lose control of their jump and bounce wildly. Performing the braking manoeuvre will allow the user to regain control of the jump and their balance.
- Start with a basic bounce.
- As you land, bend your knees sharply and this will allow you to stop your jump.



THE HANDS AND KNEES BOUNCE

- Start with a low controlled basic bounce.
- Land on your hands and knees keeping your back straight.
- Emphasis should be directed at a good four-point landing. And not on jumping height.



KNEE BOUNCE

- Start with a low controlled basic bounce.
- Land on your knees keeping back straight, body erect and use your arms to maintain balance.
- Bounce back to the basic bounce position by swinging your arms up.





SEAT BOUNCE

- Land in a flat sitting position.
- Place hands on mat beside your hips.
- Return to erect position by pushing with your hands.



REPLACEMENT PARTS LIST

If you need to replace any part of your trampoline, you can look for the Upper Bounce parts list below for each item model name :

SIZE	JUMPING MATS  Example UBMAT-7.5 (Frame size) -42 (Amt of springs) -5.5 (Spring size)	SAFETY PADS  Example UBPAD-S (Super) -7.5(Frame size) -B(Blue) / P(Premium) / G(Green) / BG(Blue Green)	SAFETY NETS				WEATHER COVERS 
			Strap Type Net (Inside) Example UBNET-7.5(Frame size) -6(Amount of poles)-IS	Strap Type Net (Outside) Example UBNET-7.5(Frame size) -6(Amt of poles)-OS	Sleeves on Top - Net (Arch) Example UBNET-7 (Frame size) -3(Amt of arches)-AST	For Curved Poles Example UBNET-8FG(Frame size) -6(Amount of poles)	
SIZE 6							
SIZE 7			UBNET-7.5-6-IS	UBNET-7.5-6-OS	UBNET-7-3-AST		
SIZE 7.5	UBMAT-7.5-42-5.5	UBPAD-S-7.5-B				UBWC-7.5	
SIZE 8	UBMAT-8-48-5.5 UBMAT-8-56-5.5 UBMAT-8-60-5.5	UBPAD-S-8-B	UBNET-8-6-IS UBNET-8-4-IS		UBNET-8-2-AST	UBWC-8	
SIZE 10	UBMAT-10-56-5.5 UBMAT-10-64-5.5	UBPAD-S-10-B	UBNET-10-4-IS UBNET-10-6-IS UBNET-10-8-IS	UBNET-10-8-OS		UBWC-10	
SIZE 11	UBMAT-11-60-5.5 UBMAT-11-72-5.5				UBNET-11-3-AST	UBWC-11	
SIZE 12	UBMAT-12-60-7 UBMAT-12-72-5.5 UBMAT-12-72-7 UBMAT-12-80-5.5	UBPAD-S-12-B UBPAD-S-12-G UBPAD-S-12-BG UBPAD-P-12-B	UBNET-12-8-IS UBNET-12-4-IS UBNET-12-6-IS	UBNET-12-4-OS UBNET-12-6-OS	UBNET-12-2-AST UBNET-12-3-AST UBNET-12-4-AST	UBWC-12-BK	UBWC-12-BL
SIZE 13	UBMAT-13-72-5.5 UBMAT-13-80-5.5 UBMAT-13-80-7	UBPAD-S-13-B	UBNET-13-6-IS UBNET-13-8-IS	UBNET-13-6-OS UBNET-13-8-OS	UBNET-13-2-ASTR UBNET-13-3-AST UBNET-13-4-AST	UBWC-13	
SIZE 14	UBMAT-14-72-5.5 UBMAT-14-72-7 UBMAT-14-80-5.5 UBMAT-14-80-7 UBMAT-14-84-7	UBPAD-S-14-B UBPAD-S-14-G UBPAD-S-14-BG UBPAD-P-14-B	UBNET-14-4-IS UBNET-14-6-IS UBNET-14-8-IS	UBNET-14-6-OS UBNET-14-8-OS	UBNET-14-3-AST UBNET-14-4-AST	UBWC-14-BK	UBWC-14-BL
SIZE 15	UBMAT-15-84-6.5 UBMAT-15-90-7 UBMAT-15-96-7	UBPAD-S-15-B UBPAD-S-15-G UBPAD-S-15-BG UBPAD-P-15-B	UBNET-15-6-IS UBNET-15-8-IS	UBNET-15-6-OS UBNET-15-8-OS	UBNET-15-3-AST UBNET-15-4-AST	UBWC-15-BK	UBWC-15-BL
SIZE 16	UBMAT-16-108-7.5	UBPAD-S-16-B	UBNET-16-6-IS			UBWC-16	
SIZE 17					UBNET-17FG-8		
		Safety Pads Square	Arch Net - Square	Oval Net	Universal Net Type		
	Square Mat	UBPADSQ-13	UBNETSQ-1313-4	UBNETO-1614 UBNETO-1715	UBNETFU1 UBNETFU2		
	Oval Mats	UBMATO-1614-96-7 UBMATO-1715-96-7					
	Band Mats	UB-BMAT-1273 UB-BMAT-1378 UB-BMAT-1484 UB-BMAT-1590					