

Metal/Glass 3-Tier Console Table

Assembly Instructions

Support loading capacities

Top: max lbs



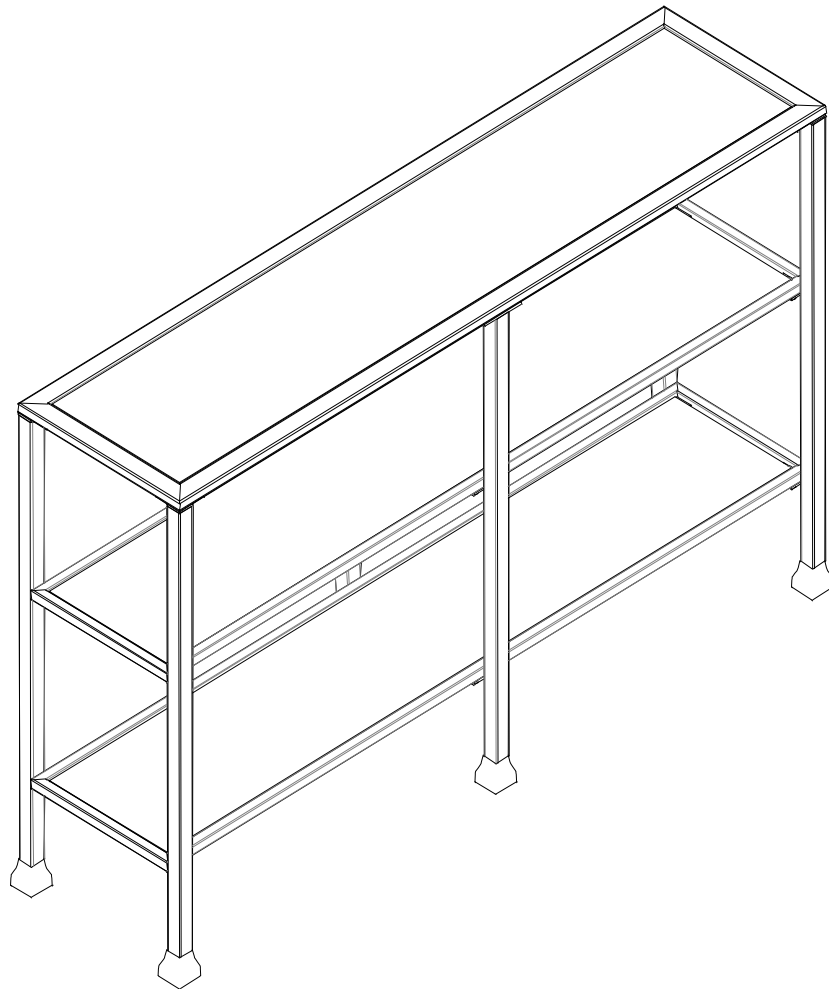



Shelf: max lbs

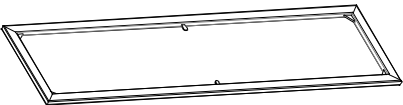
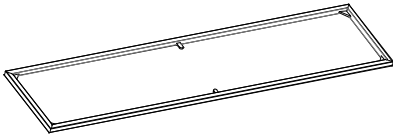

Metal/Glass 3-Tier Console Table

Parts List

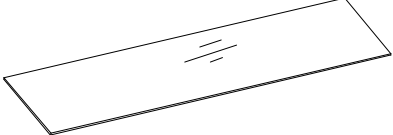
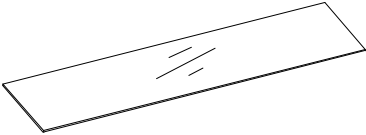
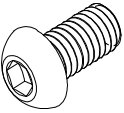
Please review all parts and hardware before disposing of any packaging.
 Before beginning assembly, separate each type of hardware. Carefully study the diagrams below and check that you have all parts indicated. Call Customer Service if missing hardware. Using the incorrect hardware will cause damage. You may receive extra hardware with your unit.

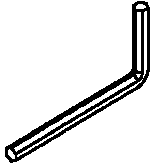
<p>1. 1PC</p>  <p>Top Frame</p>	<p>2. 2PCS</p>  <p>Shelf Frames</p>	<p>3. 2PCS</p>  <p>Legs - 3</p>
<p>4. 2PCS</p>  <p>Legs - 4</p>	<p>5. 2PCS</p>  <p>Middle Legs - 5</p>	<p>6. 1PC</p>  <p>Glass Top</p>
<p>7. 2PCS</p>  <p>Glass Shelves</p>		
<p>A. 28PCS</p>  <p>Bolts 1/4"x1/2"</p>	<p>B. 28PCS</p>  <p>Flat Washers</p>	<p>C. 18PCS</p>  <p>Glass Pads</p>
<p>D. 1PC</p>  <p>Wrench</p>		

Care and Cleaning Instructions:

Before using, wipe with a clean, dry cloth.
 Avoid rubbing or scratching the surface with rough or abrasive objects.

For replacement parts or questions, please call Customer Service.

Metal/Glass 3-Tier Console Table

Assembly Instructions

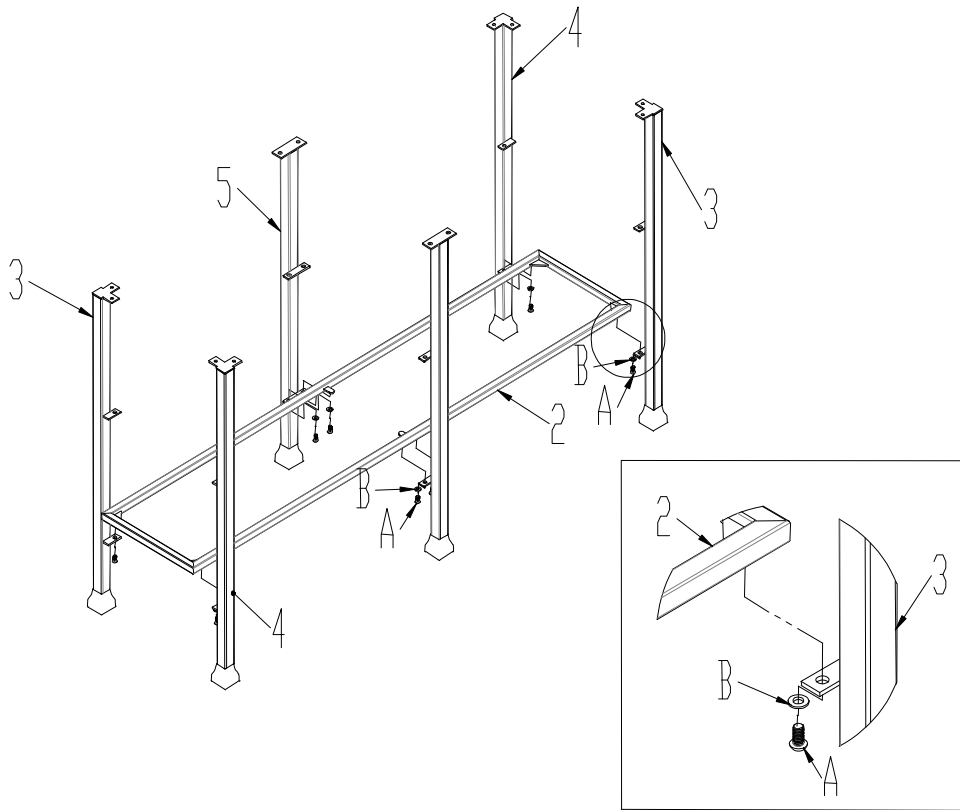

Figure 1

Note: Do not tighten bolts completely until all the bolts are in place.

Step 1:

Attach Legs-3 (3), Legs-4 (4), and Middle Legs-5 (5) to Bottom Shelf Frame (2) using Bolts (A) and Flat Washers (B) as Figure 1 shows.

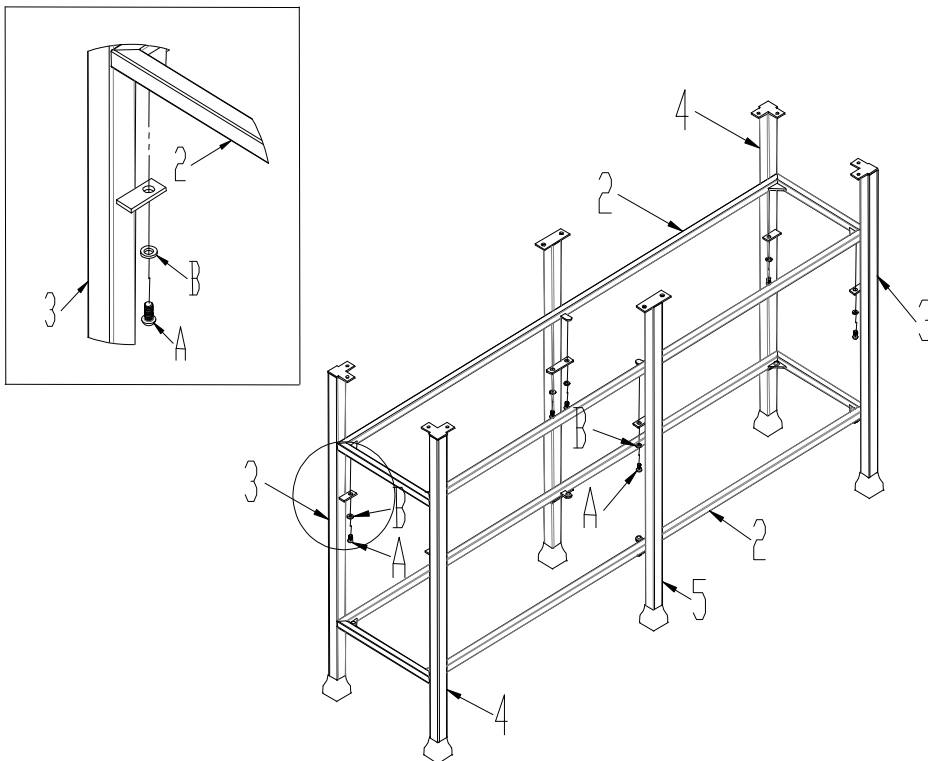

Figure 2

Step 2:

Attach Middle Shelf Frame (2) to Legs-3 (3), Legs-4 (4), and Middle Legs-5 (5) using Bolts (A) and Flat Washers (B) again as Figure 2 shows.

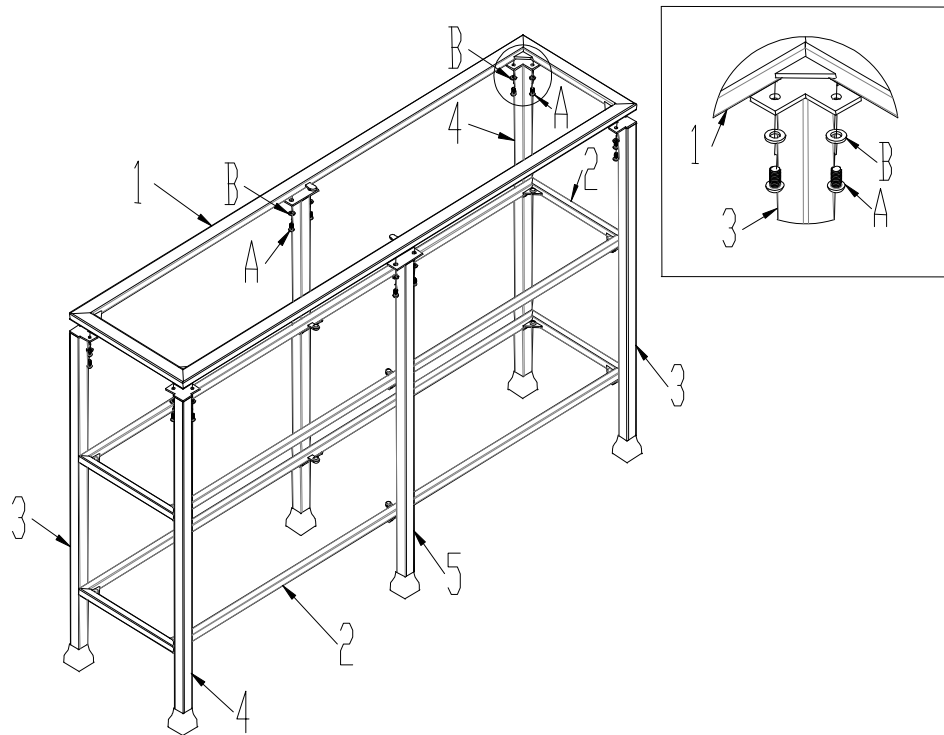

Figure 3

Step 3:

Attach Top Frame (1) to assembled unit using Bolts (A) and Flat Washers (B) as shown.

Tighten all bolts with Allen Wrench (D).

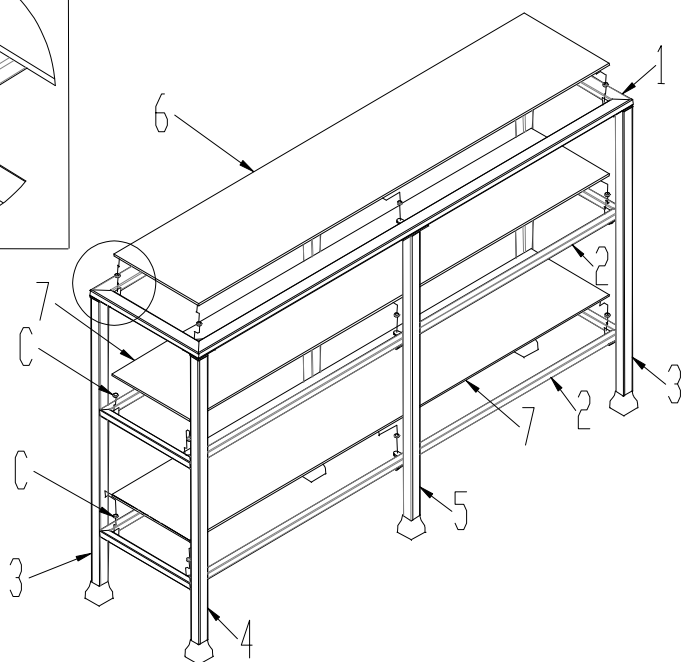
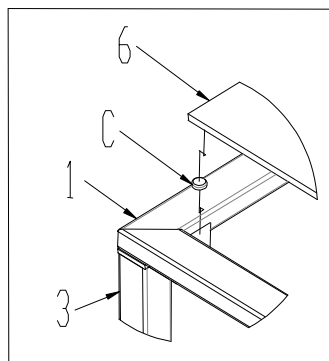

Figure 4

Step 4

Attach Glass Pads (C) to brackets on Top Frame (1) and Shelf Frames (2).

Carefully place Glass Top (6) onto brackets of Top Frame (1) and place Glass Shelves (7) onto brackets of Shelf Frames (2) as shown.

Now your Metal/Glass 3-Tier Console Table is ready to use!

Parts Replacement Form

Customer Information

Name

Address

City/State/Zip Code

Phone Number

Please indicate where you purchased this item: Store/Website/Catalog

Please indicate color/size/style number:

Style No

Parts Letter

Parts Description

Quantity Needed

Please immediately examine this product carefully. Any request for missing parts or damage replacement must be received within 90 days of your receipt of the product. Replacement, if available, will be honored within this time frame. Parts will not be available for items arriving fully assembled. We do not recommend modifying product(s) and we are not responsible for any damages due to product modification(s). If damages or missing parts are not reported within 90 days of your receipt, we are under no obligation to provide parts or replacement merchandise.

Please ask for customer service representative for issues involving damages or replacement parts. Please ask for technical assistance representative for any issues with product and assembly/construction.

Please contact the retailer that you purchased from for returns.