

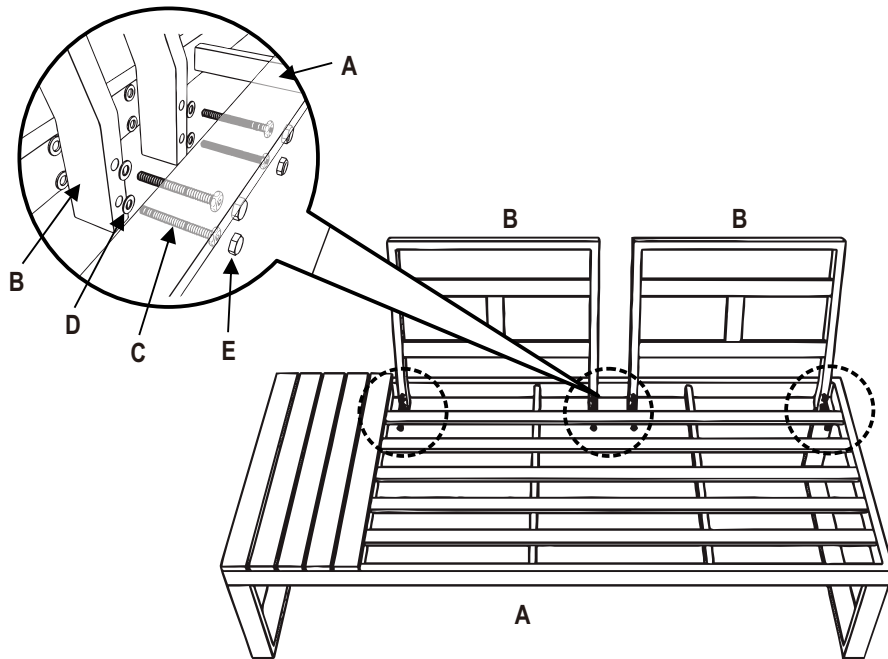







IMPORTANT!! PLEASE READ ENTIRE INSTRUCTION SHEET BEFORE ASSEMBLY!!

Id

Step 1

Carefully put the Chair Seat Part (A) on a non-abrasive surface, attach the Chair Back (B) to the Chair Seat Part (A) with Bolt (C) and Washer (D). Once the alignment is correct, tighten all the bolts (C) and then cover all the bolts (C) with Plastic Cap (E).



PARTS LIST							
A	SEAT PART		1	B	BACK		2
C	BOLT(M6*60)		8	D	METAL WASHER		8
E	CAP		8	F	SEAT CUSHION		2
G	BACK CUSHION		2	H	ALLEN WRENCH		1

Step 2

Put on the Cushion (F&G).
Now your Chair is ready for your enjoyment.

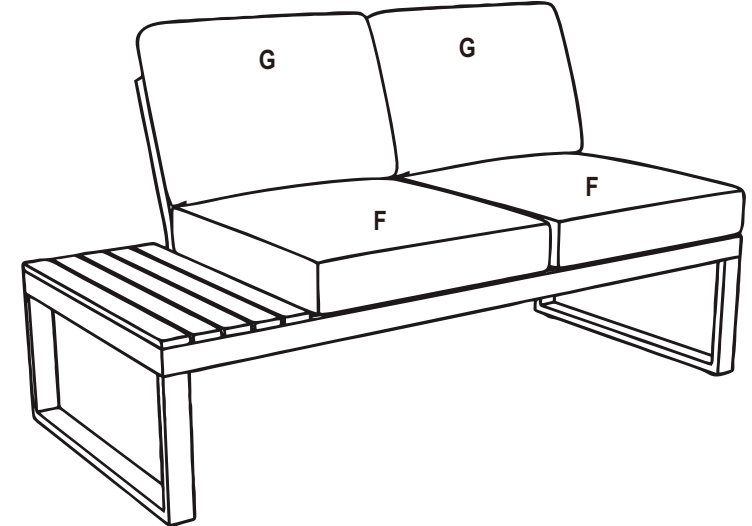







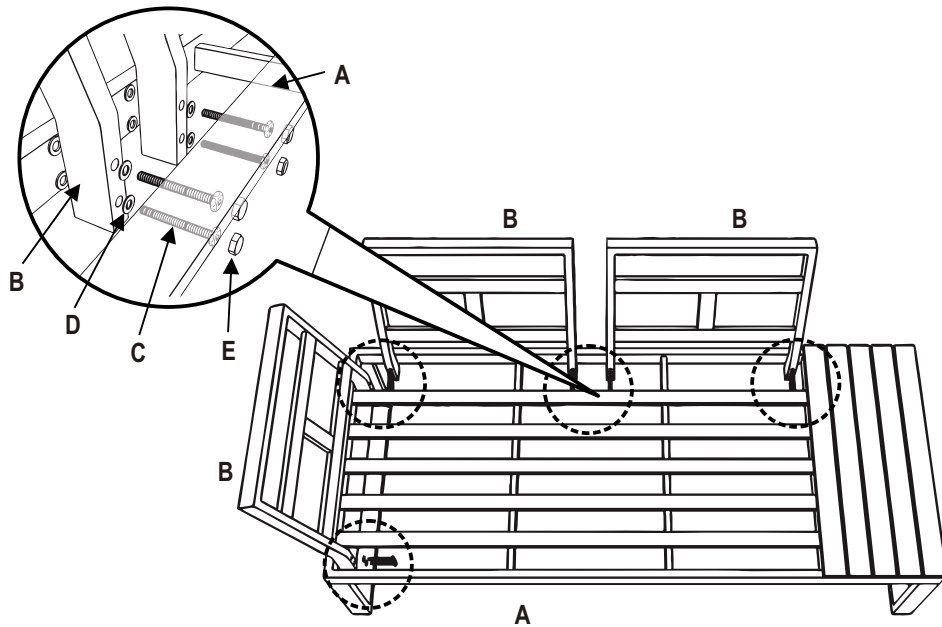



IMPORTANT!! PLEASE READ ENTIRE INSTRUCTION SHEET BEFORE ASSEMBLY!!

Step 1

Carefully put the Chair Seat Part (A) on a non-abrasive surface, attach the Chair Back (B) to the Chair Seat Part (A) with Bolt (C) and Washer (D). Once the alignment is correct, tighten all the bolts (C) and then cover all the bolts (C) with Plastic Cap (E).







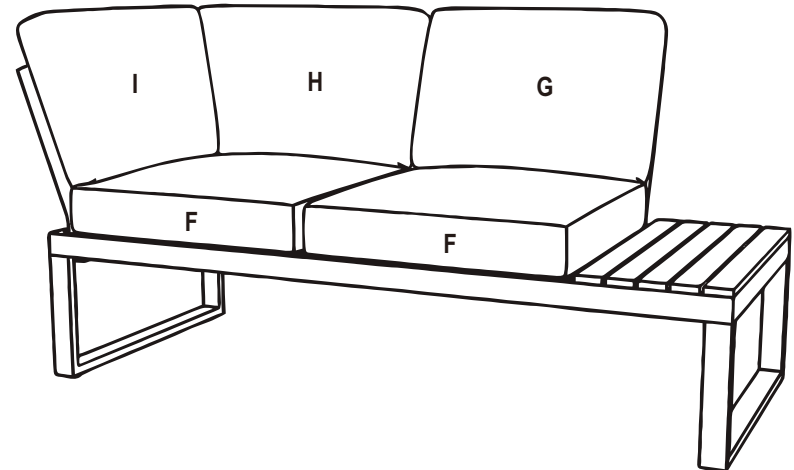

PARTS LIST							
A	SEAT PART		1	B	BACK		3
C	BOLT(M6*60)		12	D	METAL WASHER		12
E	CAP		12	F	SEAT CUSHION		2
G	BACK CUSHION		1	H	BACK CUSHION		1
I	BACK CUSHION		1	J	ALLEN WRENCH		1

Step 2

Put on the Cushion (F&G&H&I)
Now your Chair is ready for your enjoyment.



IMPORTANT!! PLEASE READ ENTIRE INSTRUCTION SHEET BEFORE ASSEMBLY!!

PARTS LIST							
A	TABLE TOP		1	B	TABLE LEG		2
C	CONNECTOR BAR		2	D	BOLT(M6*16)		12
E	METAL WASHER		12	F	CAP		12
G	ALLEN WRENCH		1				

Step 1

Assemble the Connector Bar (C) to the Table Leg (B) with Bolt (D) and Washer (E).

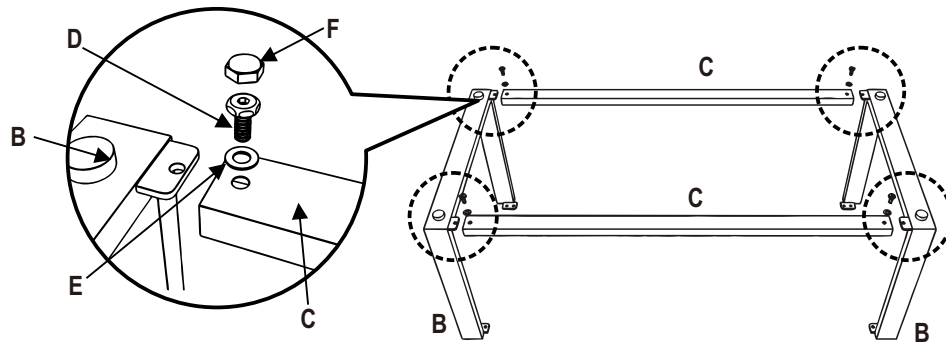

Step 2

Carefully turn the Table Top (A) upside down on a non-abrasive surface, attach the figure 1 to the Table Top (A) with Bolt (D) and washer (E). Once the alignment is correct, tighten all the bolts (D) and then cover all the bolts (D) with Plastic Cap (F).

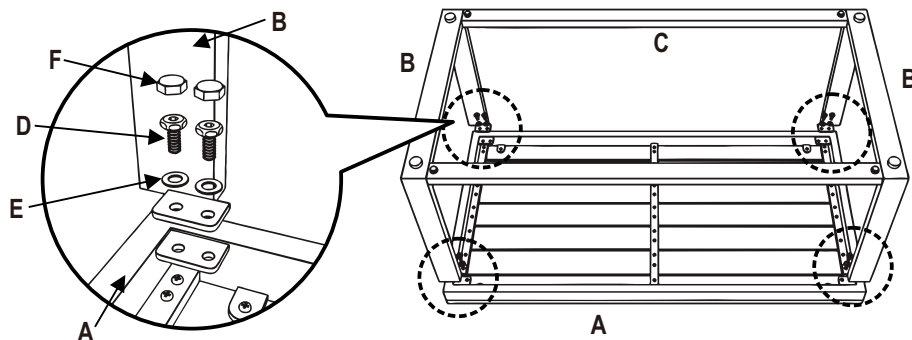

Step 3

Turn your table right side up .Now your Table is ready for your enjoyment.

