

# **ASSEMBLY INSTRUCTION**

**ITEM NO. THKFBV170WH1B2**

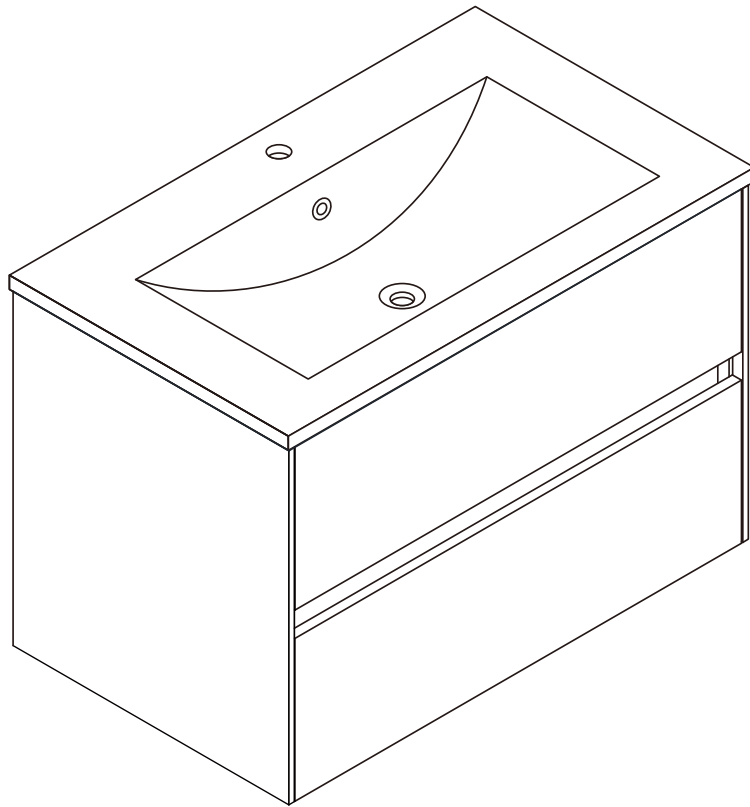

# IMPORTANT NOTICE

## Workspace Safety

Keep the workspace clear of clutter and ensure it's well-lit. A clean, flat surface is essential.

## Read Instructions

Read the entire assembly guide before starting. Skipping steps can compromise safety.

## Use Proper Tools

Use the tools provided or recommended. Avoid overtightening screws.

## Secure Furniture

Anchor tall or heavy furniture to the wall to prevent tipping. This is crucial in homes with children or pets.

## Handle Small Parts

Keep small parts away from children and pets to avoid choking hazards.

## Get Help

Don't hesitate to ask for help with heavy or complex pieces.

## Inspect Regularly

Periodically check for loose screws or wobbly parts and tighten as needed.

Follow these tips for a safe assembly process.

 <b>WARNING</b>	
	<p><b>Serious or fatal crushing injuries can occur from furniture tip-over. To help prevent tip-over:</b></p> <ul style="list-style-type: none"><li>• Install tipover restraint provided.</li><li>• Place heaviest items in the lowest drawers.</li><li>• Do not set TV's or other heavy objects on top of this product, unless the product is specifically designed to accommodate them.</li><li>• Never allow children to climb or hang on drawers, doors or shelves.</li><li>• Never open more than one drawer at a time</li></ul>
	<p>Use of tip-over restraints may only reduce, but not eliminate, the risk of tip-over.</p> <p>This is a permanent label. Do not remove!</p>

# ASSEMBLY DIAGRAM

1. Refer to the exploded view below for the approximate location of each component.
2. Each part is labeled for easy identification.
3. Follow the assembly instructions carefully to ensure proper installation.

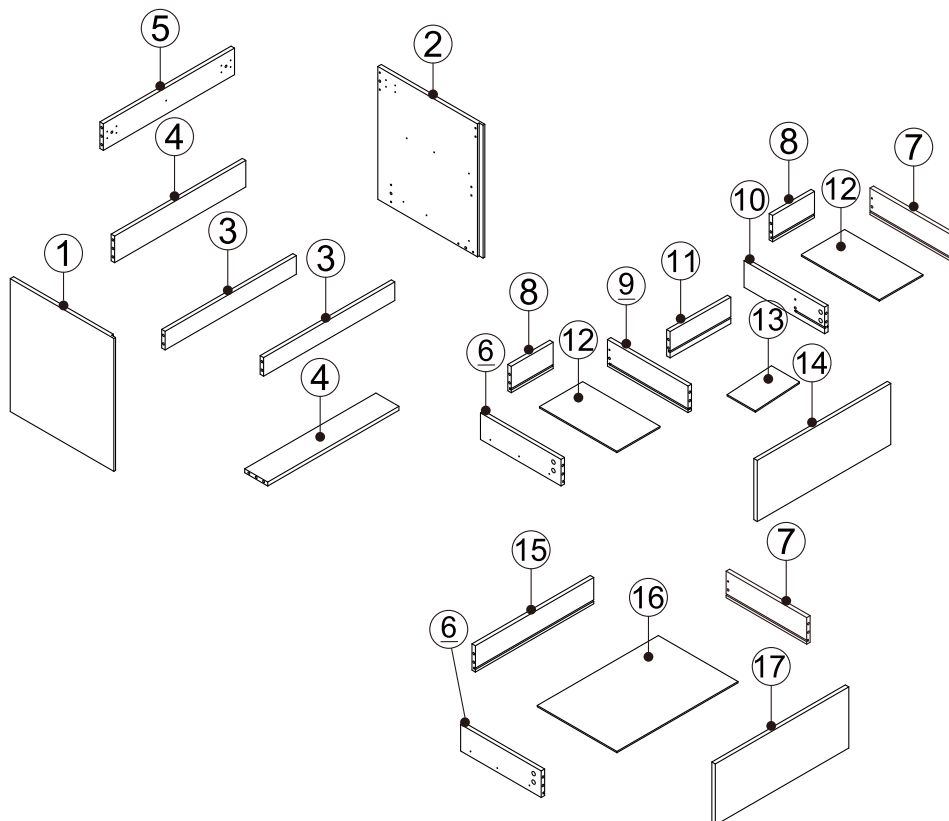
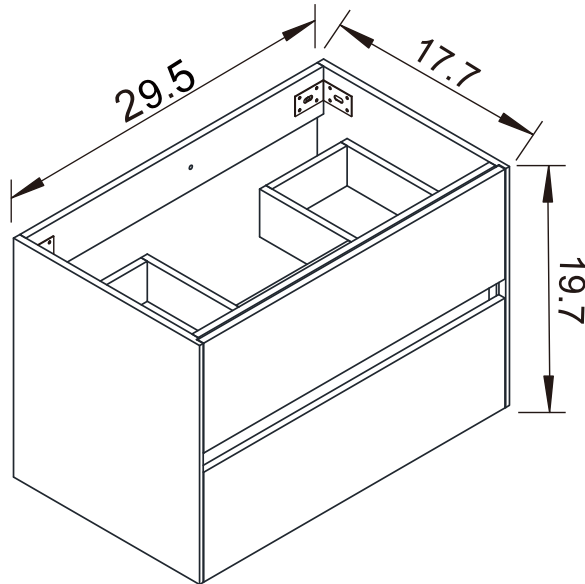







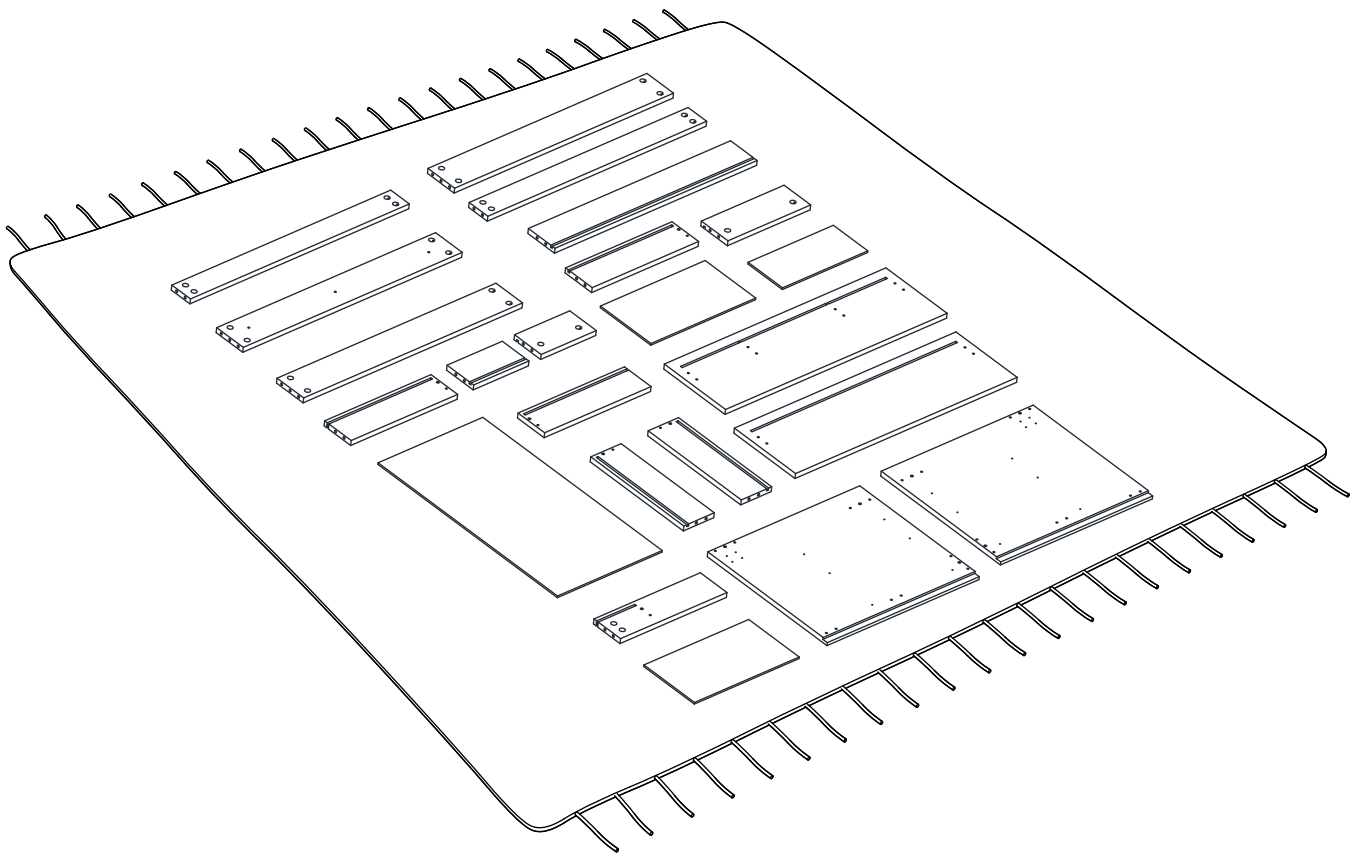



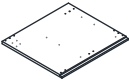
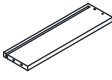
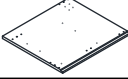
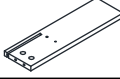

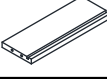
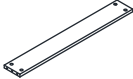
## PRE-ASSEMBLY PREPARATION

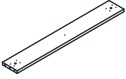

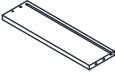
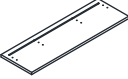
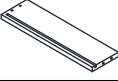

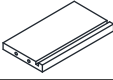

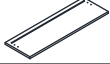
Before assembly, place all furniture parts on a soft surface, such as a blanket or the original packaging cardboard, to prevent damage to the floor or components from accidental drops and to avoid scratching the surfaces.

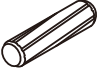

# PARTS LIST

No.	Description	QTY	No.	Description	QTY
1		1	9		1
2		1	10		1
3		2	11		1
4		2	12		2
5		1	13		1
6		2	14		1
7		2	15		1
8		2	16		1
17		1			

# HARDWEAR LIST

No.	Description	QTY	No.	Description	QTY
A		40			
B	 7X30mm	14			
C	 4X14mm	40			
D		4			
E		3			
F		2			
G		1			

**CAUTION:** Please confirm the parts list before installtion

# YOU MAY NEED (NOT SUPPLIED)

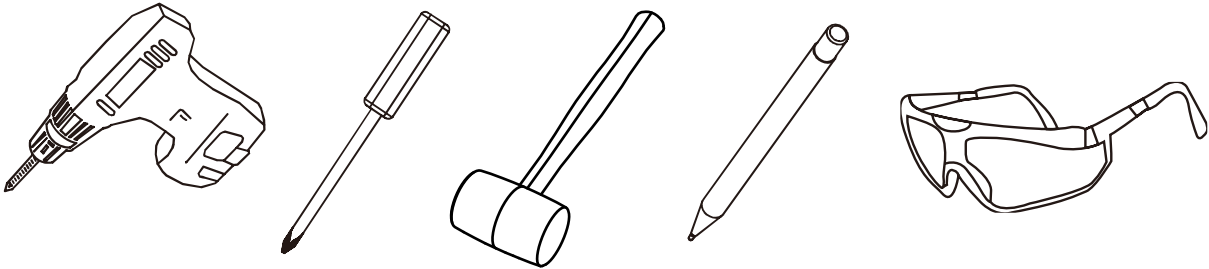

1

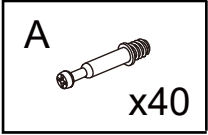

● Insert the Cam Screw into the shelves above.

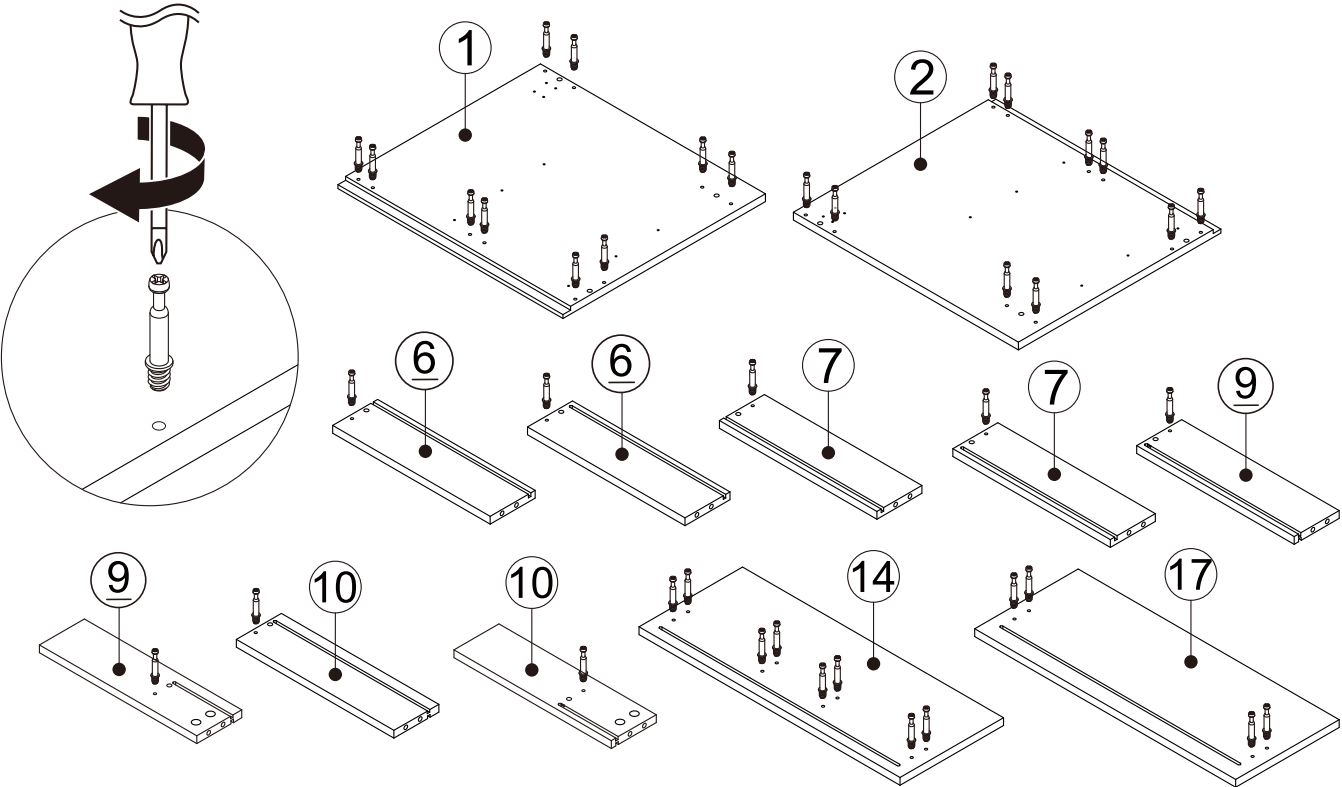

# 2

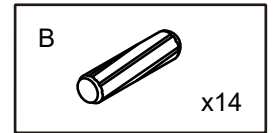

● Insert the wooden dowel pins into the shelves.

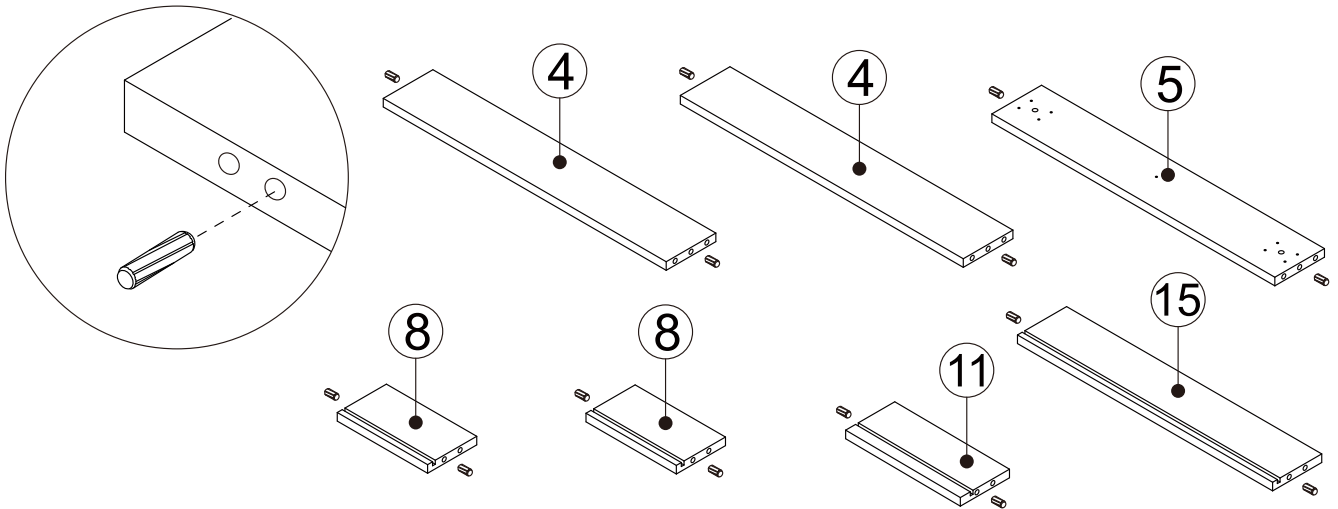

# 3

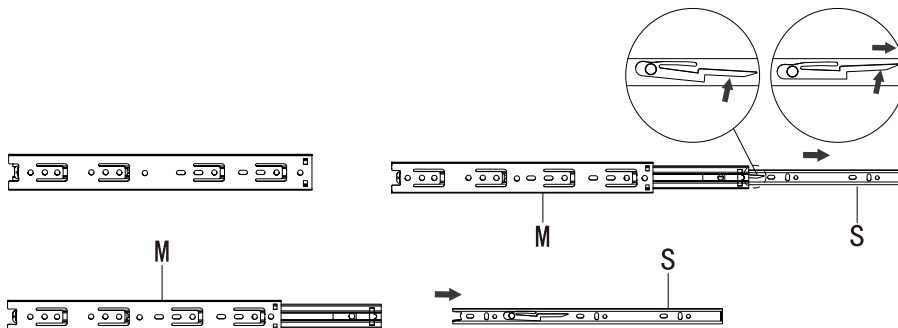
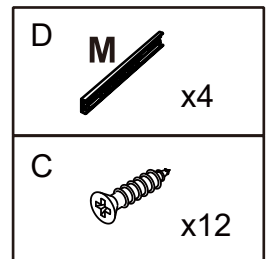

● Keep pressing here, then pull out to divide the slide.

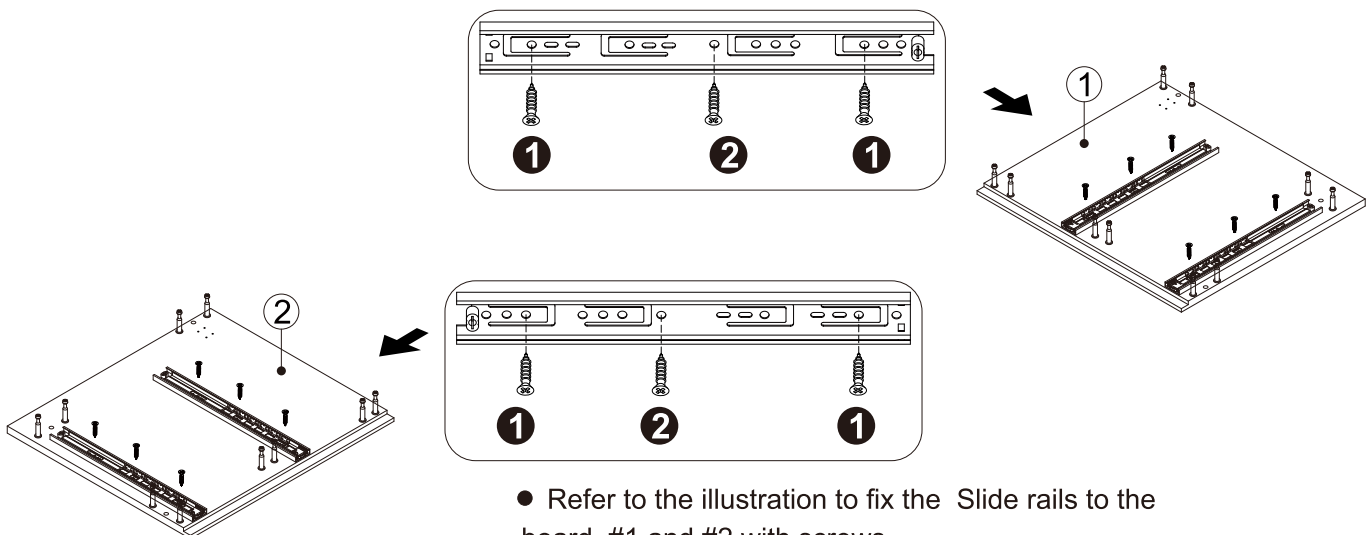

● Refer to the illustration to fix the Slide rails to the board #1 and #2 with screws.

# 4

● Refer to the illustration, insert the shelves #3,#4,#5 on the shelf #2. Then tighten the cam lock with the cover.

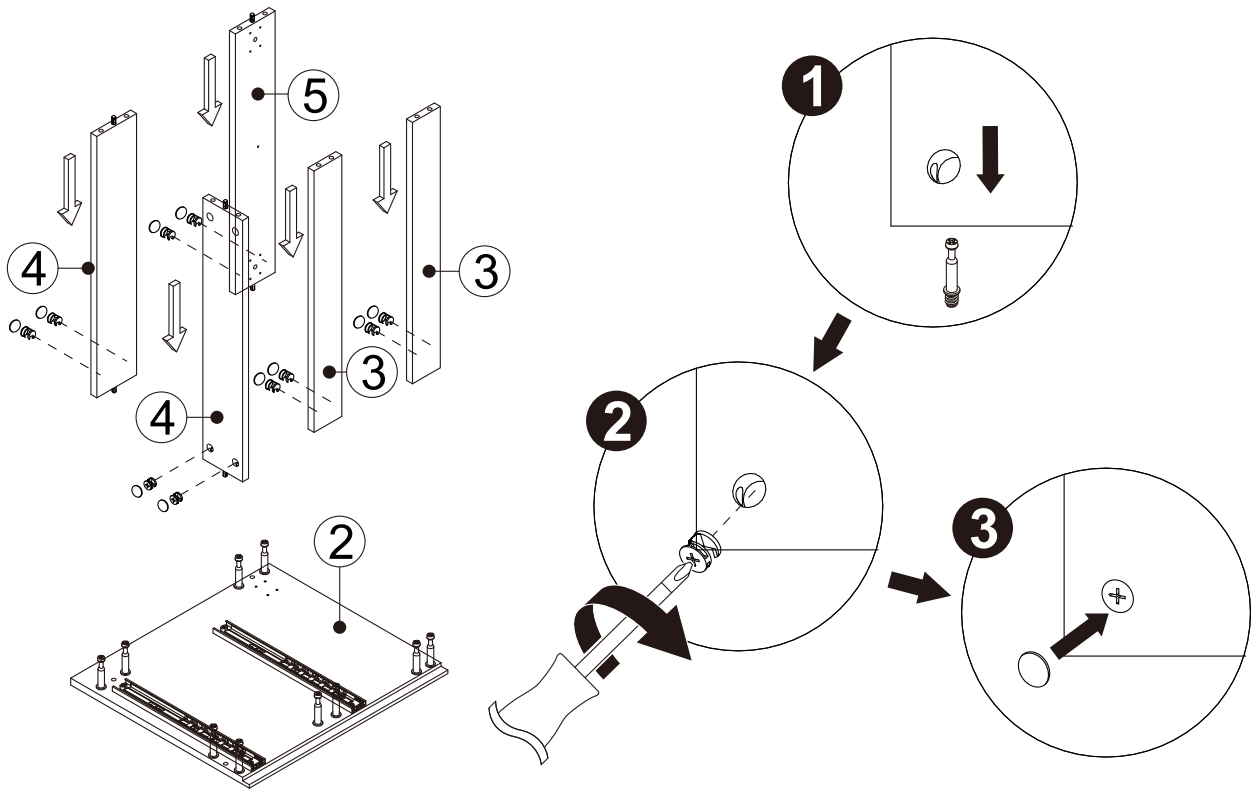
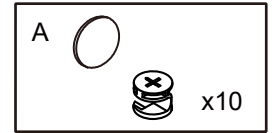

# 5

● Refer to the illustration, install shelf #1 on the cabinet. Then tighten the cam lock with the cover.

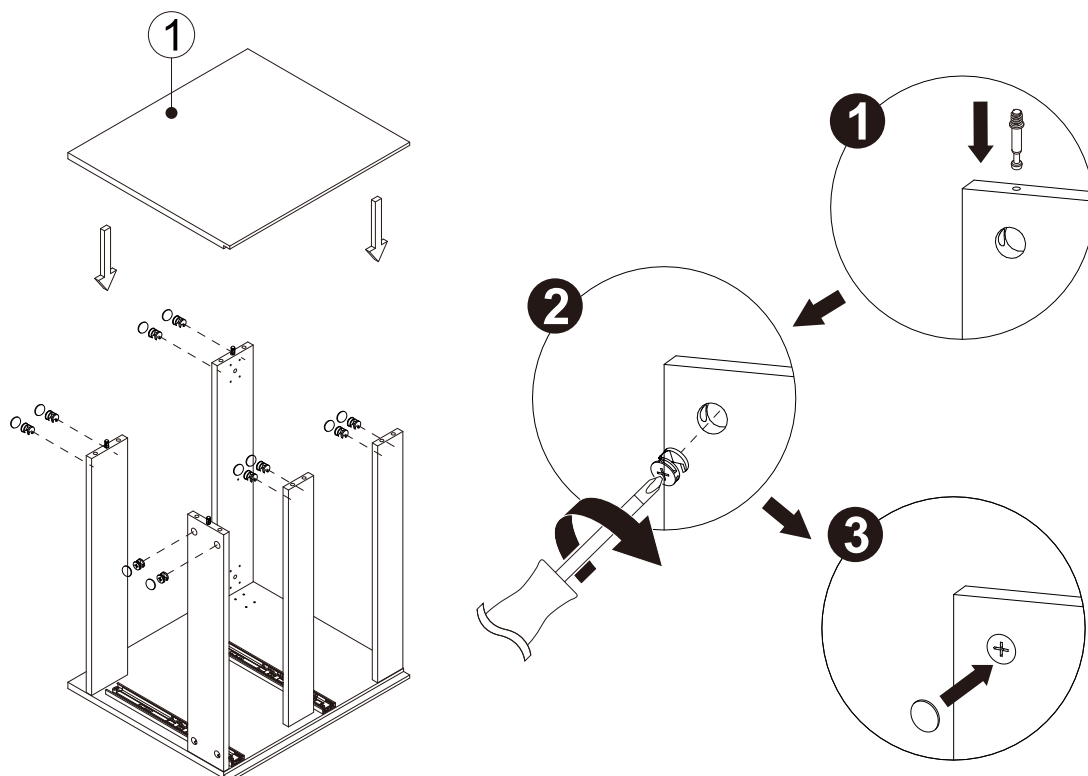
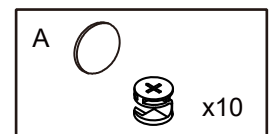

# 6

● Refer to the illustration, connect the plates #6,#8 #9 together,connect the plates #7,#8,#10 together, Then tighten the cam lock with the cover.Insert the plate #12 into the finished shelves.

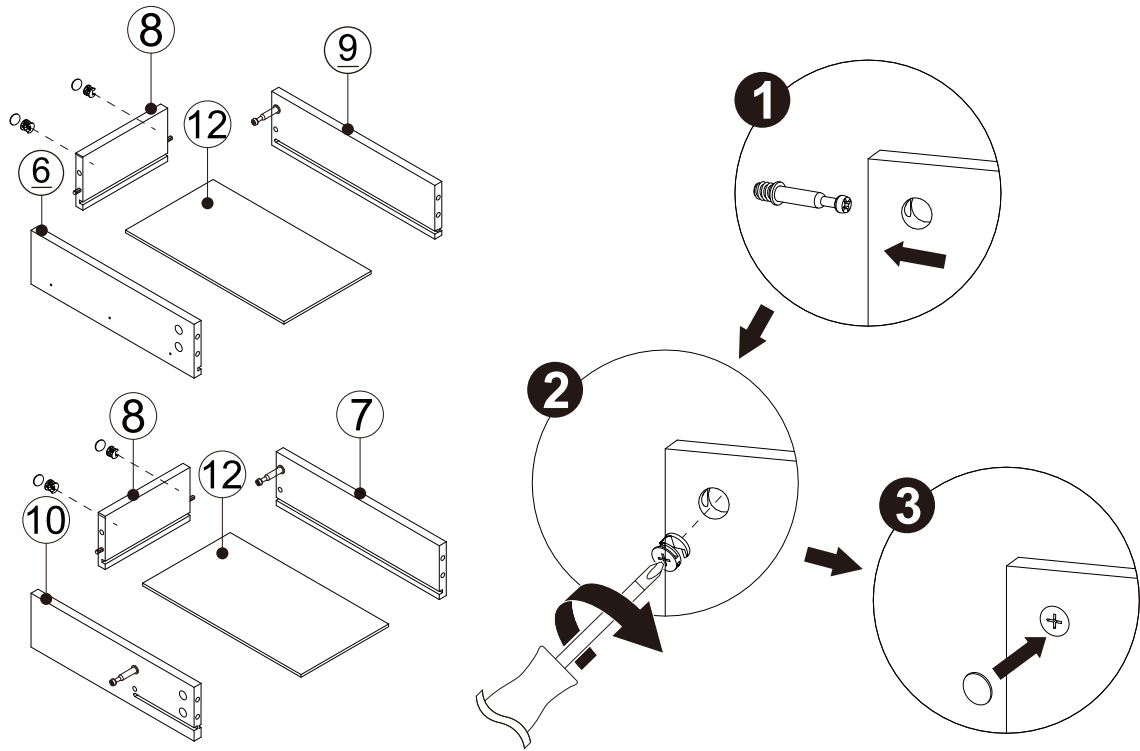
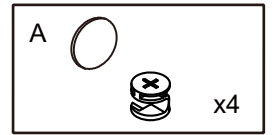

# 7

● Connect the assembled shelves to the plate #11 together,then tighten the cam lock with the cover. Insert the plate #13 into the finished shelf.

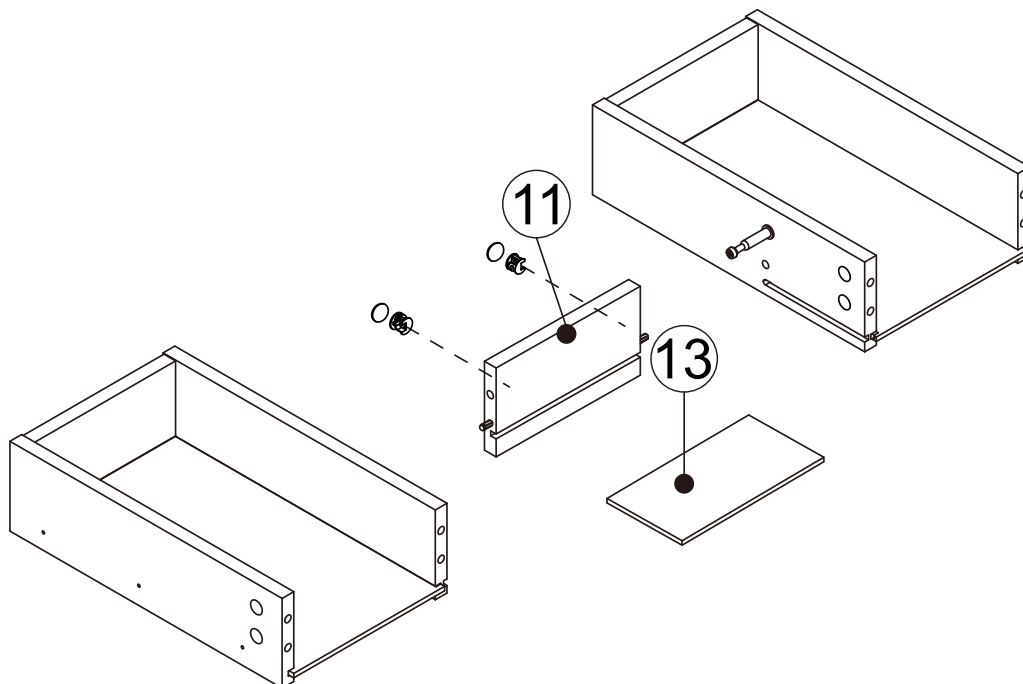
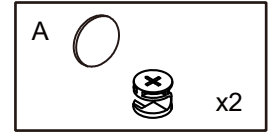

# 8

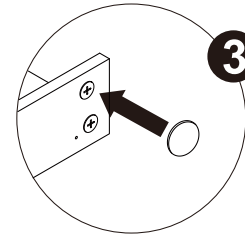
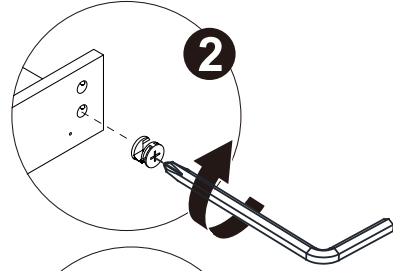
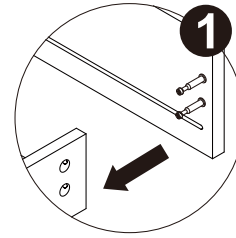
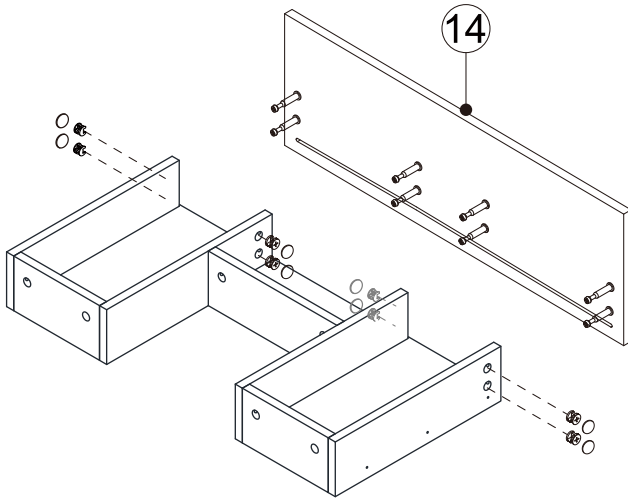
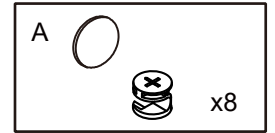

- Refer to the illustration, Draw the panel #14 is inserted into the prepared plate, Then tighten the cam lock with the cover.

# 9

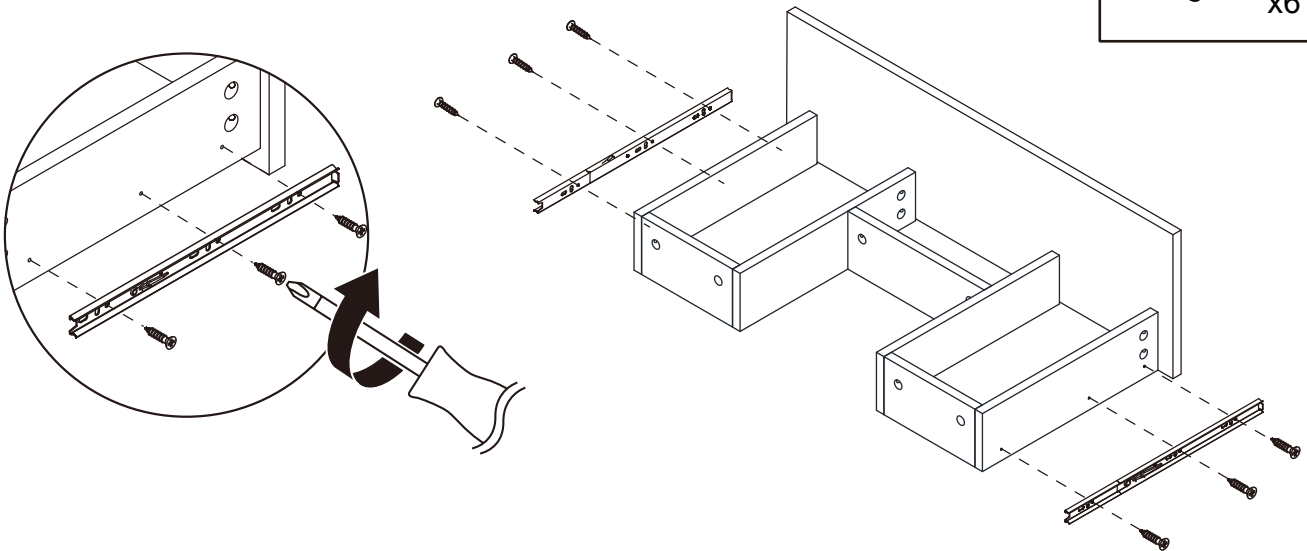
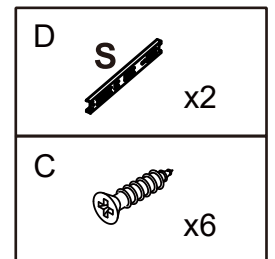

- Refer to the illustration, Apply screws to fix the slides on the boards #6,#7.

# 10

- Refer to the illustration, connect the plates #6,#7 #15 together, Then tighten the cam lock with the cover. Insert the plate #16 into the finished shelf.

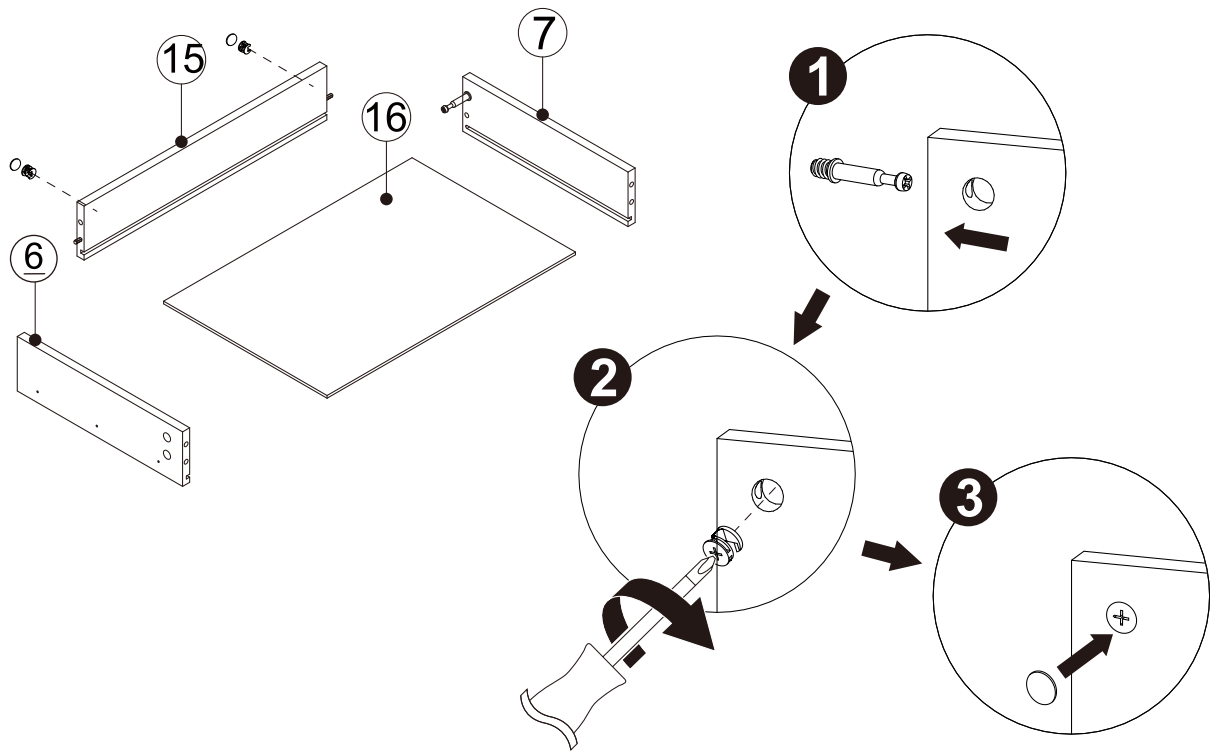
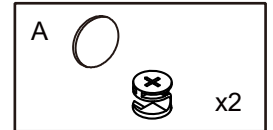

# 11

- Refer to the illustration, Draw the panel #17 inserted into the prepared plate, Then tighten the cam lock with the cover.

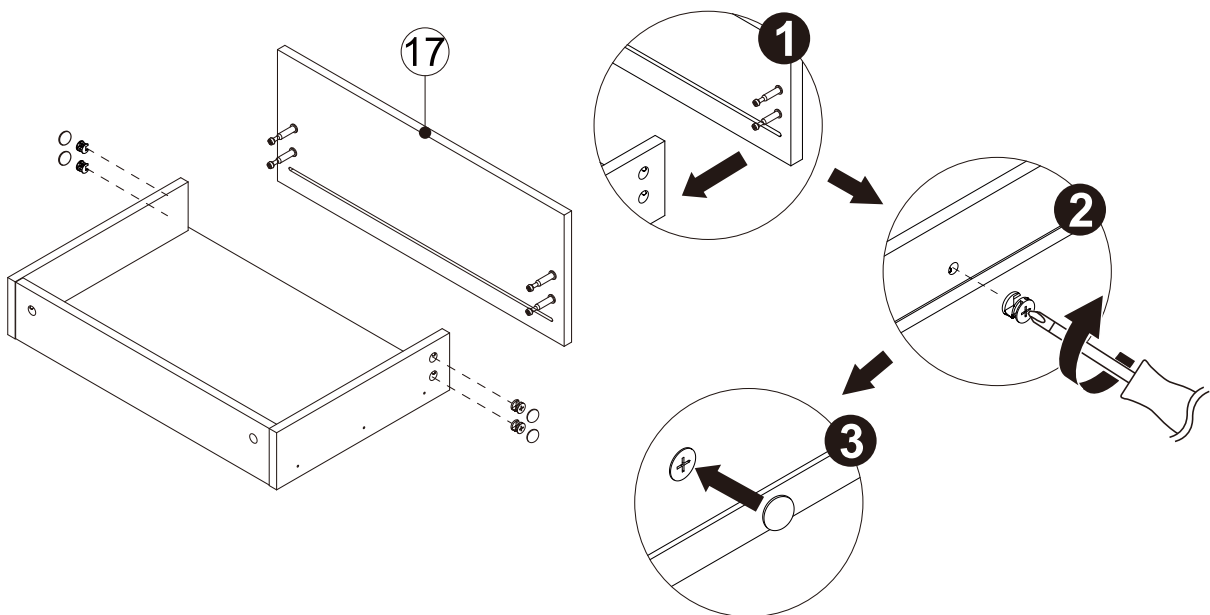
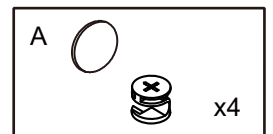

# 12

- Refer to the illustration, Apply screws to fix the slides on the boards #6,#7.

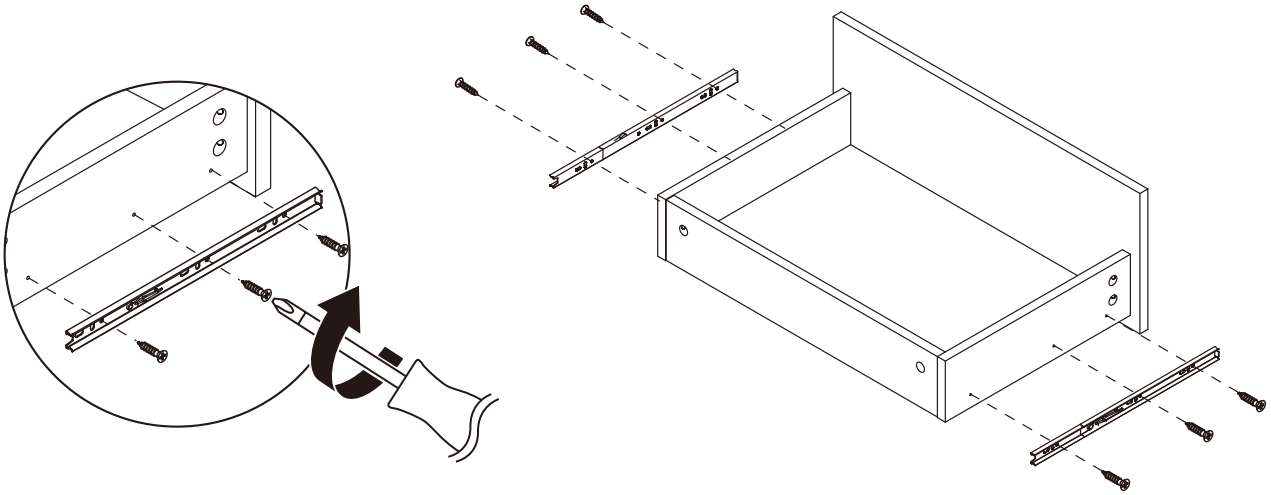
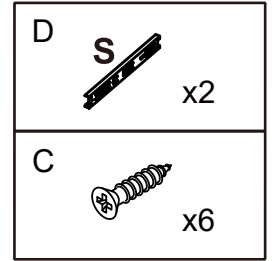

# 13

- Refer to the illustration,use screws to secure the bracket to the plate.

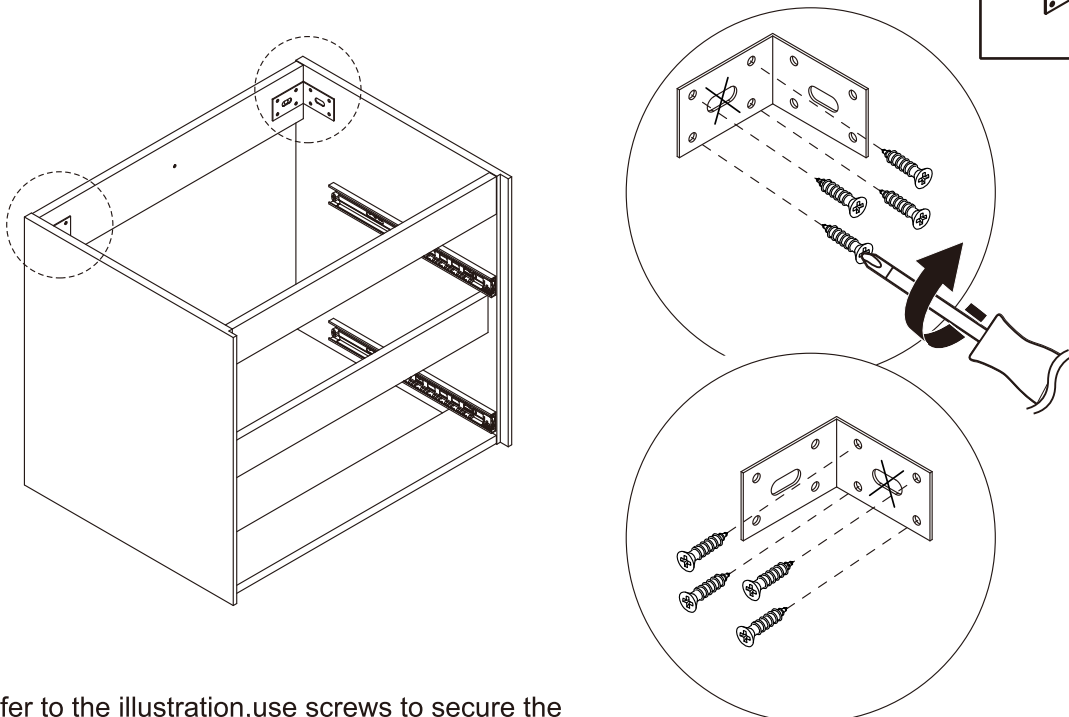
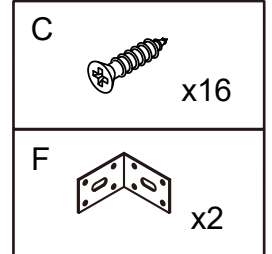

# 14

- Refer to the illustration, Draw the spacing between the walls on the cabinet, punch holes in the wall, and fix the cabinet to the wall with screws. Then tighten the nut cover.

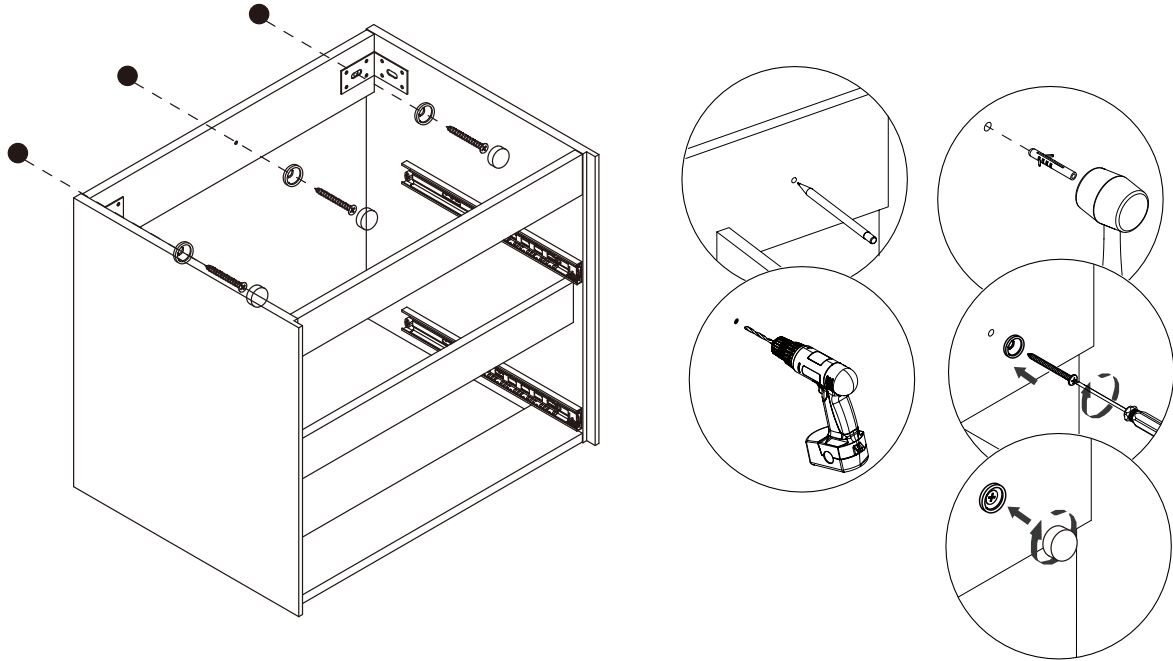
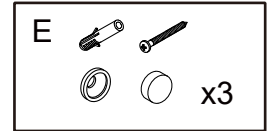

# 15

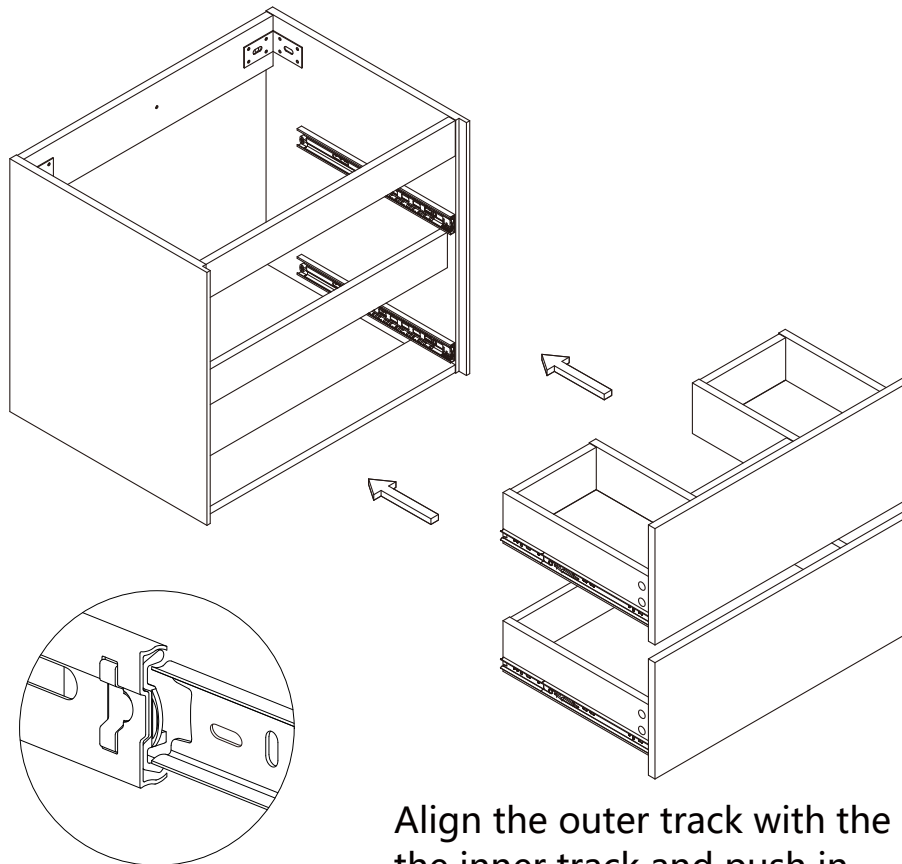

Align the outer track with the center of the inner track and push in.

# 16

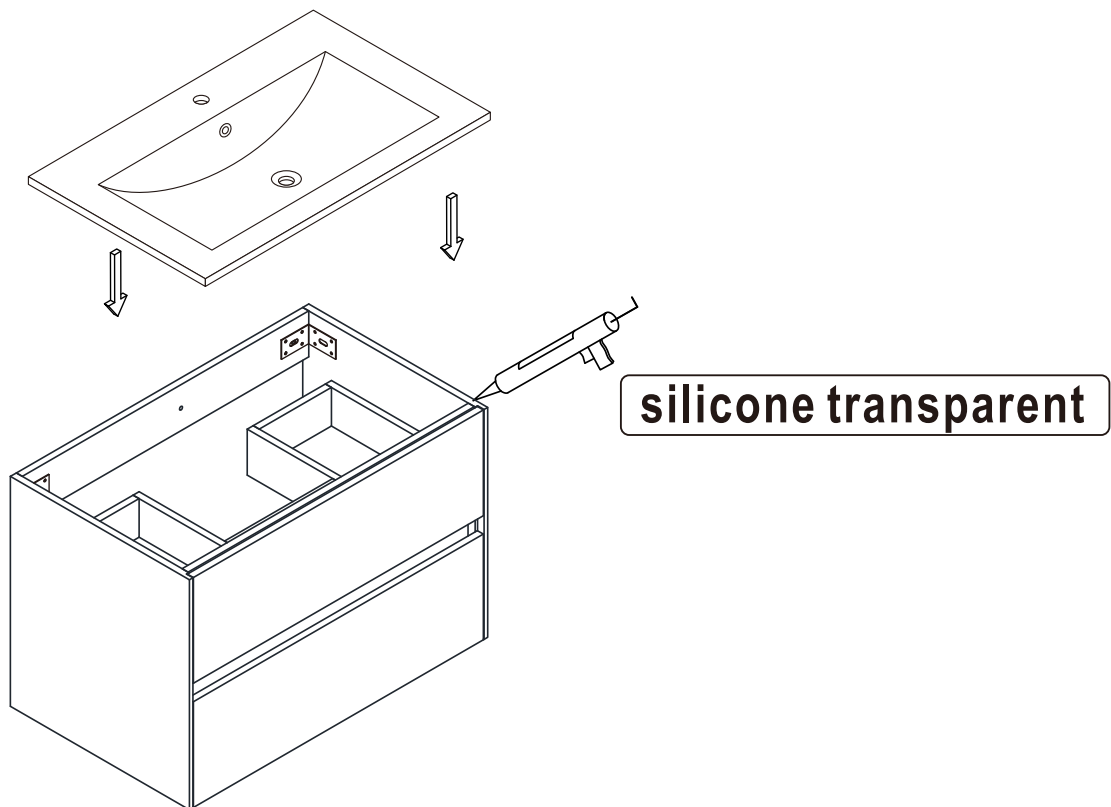

# 17

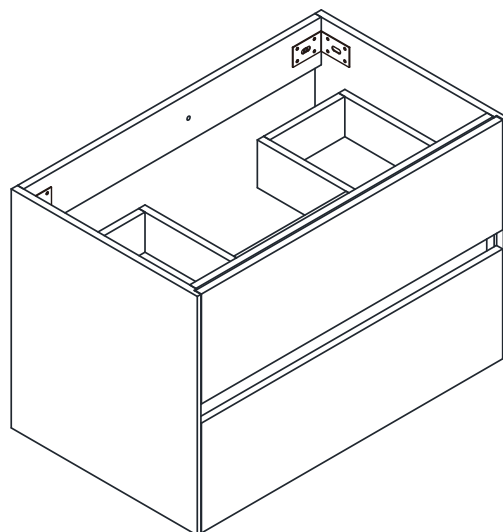

- To help prevent mildew, apply sealant to the space between the wall and the edge of the cabinet.

# THANK YOU

Thank you for choosing our product. We sincerely hope that the assembly process has been smooth and enjoyable for you. If you have any questions or suggestions during the use of the product, please feel free to contact us.

Contact number: (323)-393-8260 at EST 9AM-1PM

E-mail: [uev\\_eusupport@163.com](mailto:uev_eusupport@163.com)

