

NOTICE

- * Please make sure that you have all parts indicated and they are in good condition before you begin assembly of this item. Refer to part list and hardware list below for guidance.
- * This item should be assembled on a soft surface to prevent scratching the finish during assembly.
- * This item may require periodic tightening.
- * If you are having difficulty, our friendly Customer Care team is always here to help. Please

email customersupport@safavieh.com

PREPARATION





- * Before beginning assembly of product, make sure all parts are present. Compare parts with part contents list and hardware contents list.
- * If any part is missing or damaged, do not attempt to assemble the product.
- * Estimated Assembly Time: **10 minutes**
- * Tools Required for Assembly (included): **Allen Key**

CARE AND MAINTENANCE

Wipe spills immediately. Maintain with regular dusting and clean with mild soap and water, dry thoroughly and do not use a brass cleaner. Adhesive felt pads should always be used/applied in order to prevent damage to the furniture or surfaces on which the furniture is placed

To prevent overall soiling, frequent vacuuming or light brushing is recommended. Cushions and pillows should be turned on a weekly basis. Down-filled cushions should be brushed rather than vacuumed. Spot clean, using a mild water-free solvent or dry cleaning product. Only a professional cleaner should undertake a complete overall cleaning. The use of steam or water-based cleaners may cause excessive shrinking or staining.

Part List and Hardware List

PIECE	DESCRIPTION	PICTURE	QUANTITY
A	UPHOLSTERY TOP		1X
B	LEG		2X
C	STRECHER		1X
HW1	BOLT M6 x 12 MM		12X
HW2	ALLEN KEY 4 MM		1X



MODEL#BCH3704B

PRODUCT DIMENSION : 53"W X 16"D X 17"H

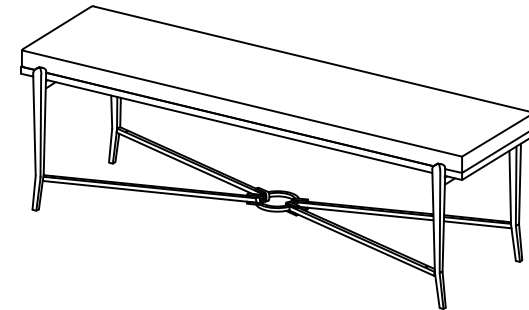

WEIGHT CAPACITY : 330 LBS

WARNING : DO NOT OVER TORQUE BOLTS/SCREWS .

WARNING : DO NOT STAND ON THE BENCH.

PREPARATION

- * Before beginning assembly of product, make sure all parts are present. Compare parts with part contents list and hardware contents list.
- * If any part is missing or damaged, do not attempt to assemble the product.
- * Estimated Assembly Time: 10 minutes.
- * Tools Required for Assembly (included): Allen Key
- * If you are having difficulty, our friendly Customer Care team is always here to help. Please email customersupport@safavieh.com

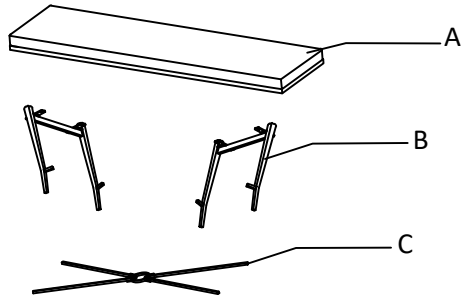

STEP 1: OPEN THE ZIPPER ATTACHED ON THE CARTON AND TAKE OUT UPHOLSTERY TOP (A) ,LEGS (B) , STRECHER (C) & HARDWARE BAG FROM THE CARTON.

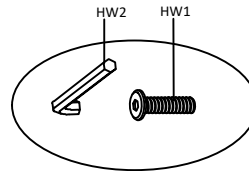

STEP 2: PUT THE ALLEN KEY (HW2) ON THE BOLT (HW1) IN THE ORDER AS SHOWN IN THE ABOVE PICTURE.

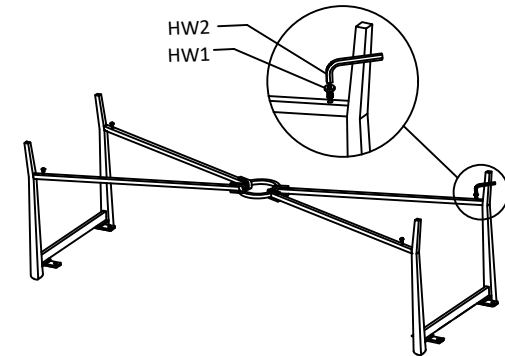

STEP 3: THERE AFTER SCREW BOLTS ALIGNED ON THE STRETCHER & TIGHTEN THEM USING ALLEN KEY AS SHOWN IN THE ABOVE PICTURE.

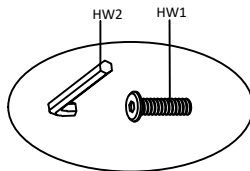

STEP 4: PUT THE ALLEN KEY (HW2) ON THE BOLT (HW1) IN THE ORDER AS SHOWN IN THE ABOVE PICTURE.

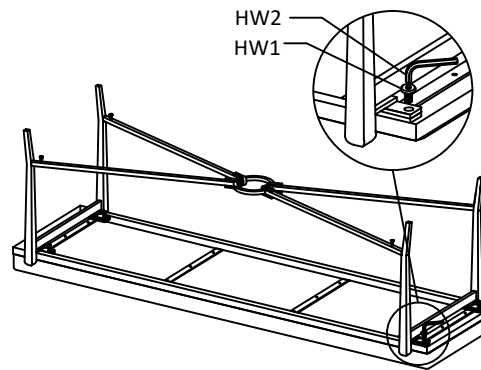

STEP 5: THERE AFTER SCREW BOLTS ALIGNED ON THE UPHOLSTERY TOP ON THE LEGS AS SHOWN IN THE ABOVE PICTURE.

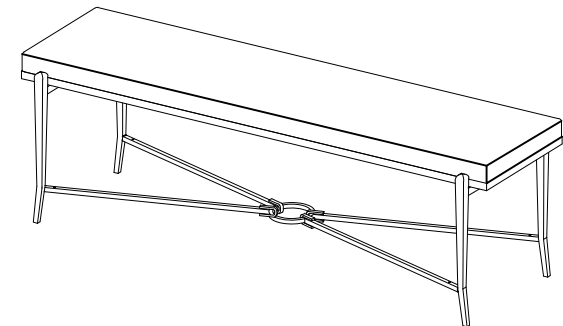

STEP 6: FINAL ASSEMBLED PIECE & IT IS READY TO USE.