

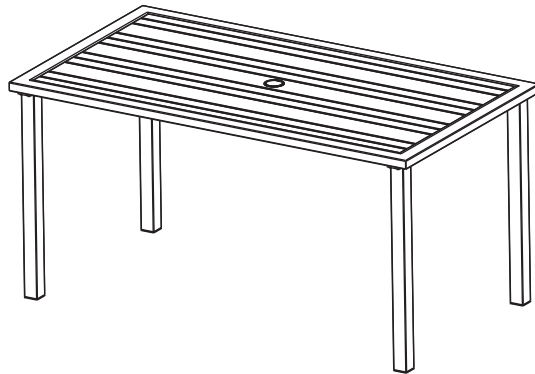

Assembly Instructions
Instructions de montage
Instrucciones de montaje

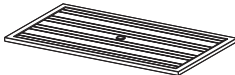



Table

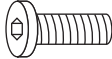

Parts List-Liste des pieces-Lista de partes

NO.	Picture	Description	Qty
A		Table Top	1
B		Table Leg	4

Hardware-Matériel-Hardware

NO.	Picture	Description	Qty
C		Bolt (6. 35MM X 20 MM)	16
D		Washer (Ø6.5 X 1.0 MM)	16
E		Hex Bolt Driver	1
		Adjustable Foot Factory Assembly	
		Umbrella Hole Protective Ring Factory Assembly	

Assembly Preparation-Preparación de montaje-Preparación de montaje

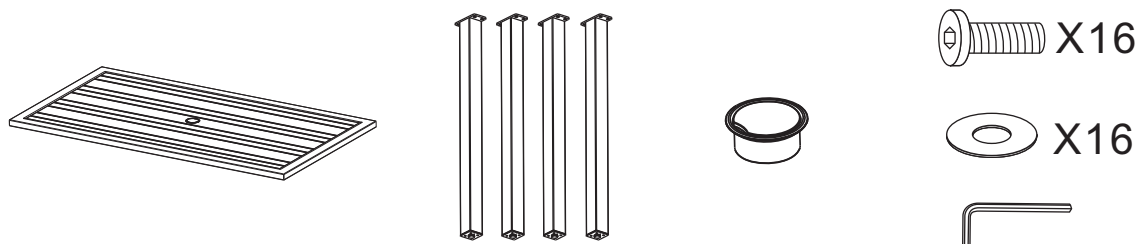

DO NOT FULLY TIGHTEN BOLTS UNTIL THE ITEM IS FULLY ASSEMBLED.

NE SERREZ PAS COMPLÈTEMENT LES BOULONS JUSQU'À CE QUE L'ARTICLE SOIT COMPLÈTEMENT ASSEMBLÉ.

NO APRIETE COMPLETAMENTE LOS PERNOS HASTA QUE EL ARTÍCULO ESTÉ COMPLETAMENTE MONTADO.

Assembly Steps-Étapes d'assemblage-Pasos de montaje

Overview

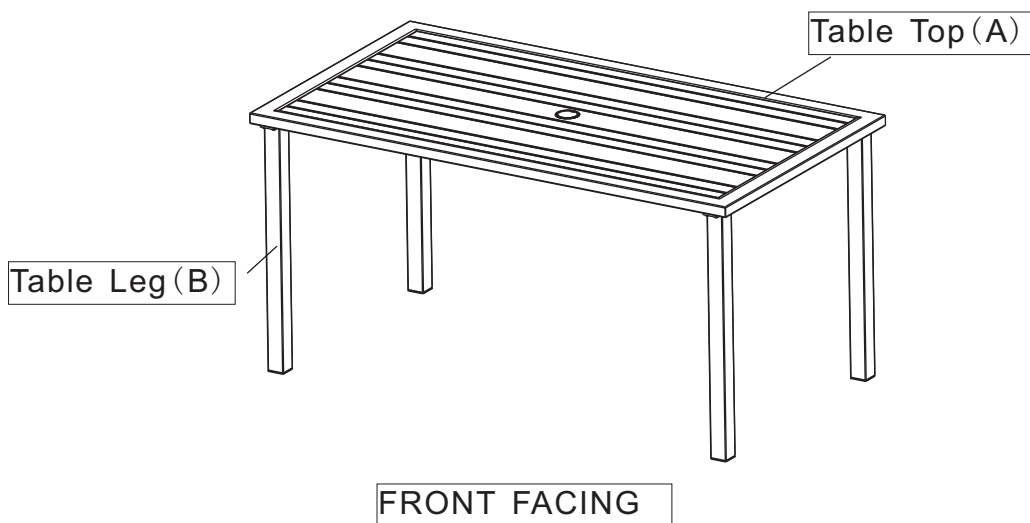

Step 1

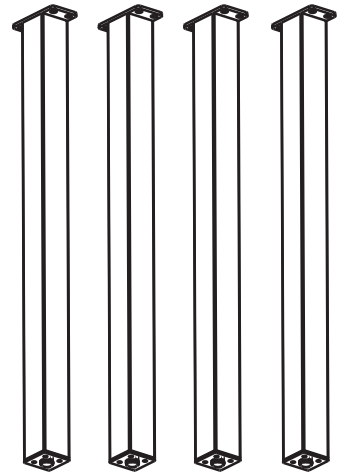
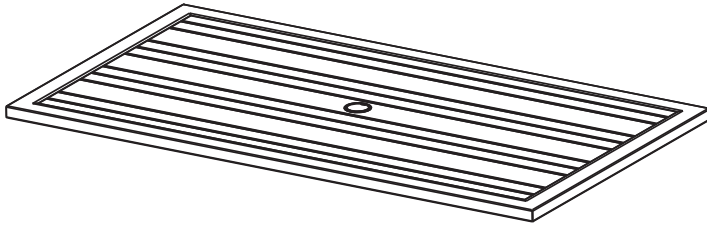

Step 2

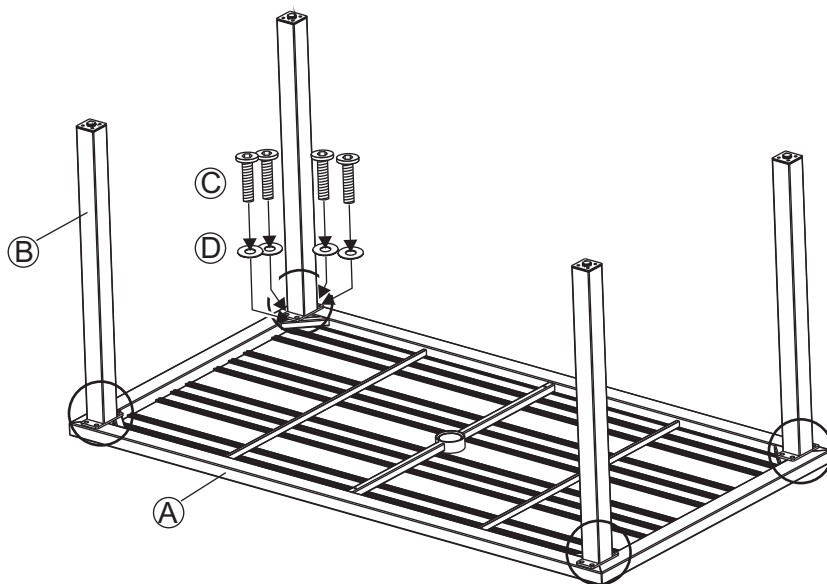

Step 3

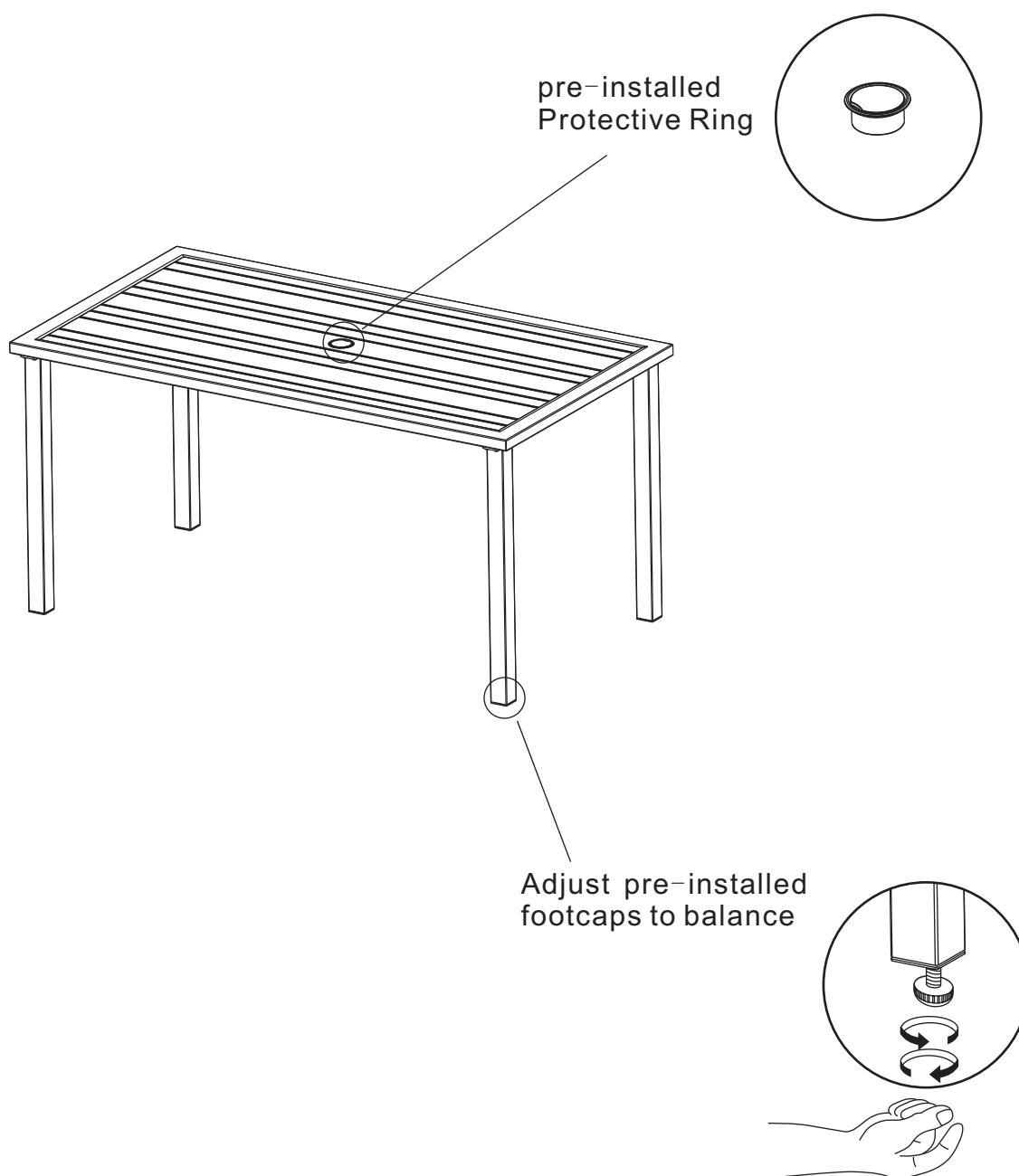

DO NOT FULLY TIGHTEN BOLTS UNTIL THE ITEM IS FULLY ASSEMBLED.

NE SERREZ PAS COMPLÈTEMENT LES BOULONS JUSQU'À CE QUE L'ARTICLE SOIT COMPLÈTEMENT ASSEMBLÉ.

NO APRIETE COMPLETAMENTE LOS PERNOS HASTA QUE EL ARTÍCULO ESTÉ COMPLETAMENTE MONTADO.