

# INSTALLATION & ASSEMBLY

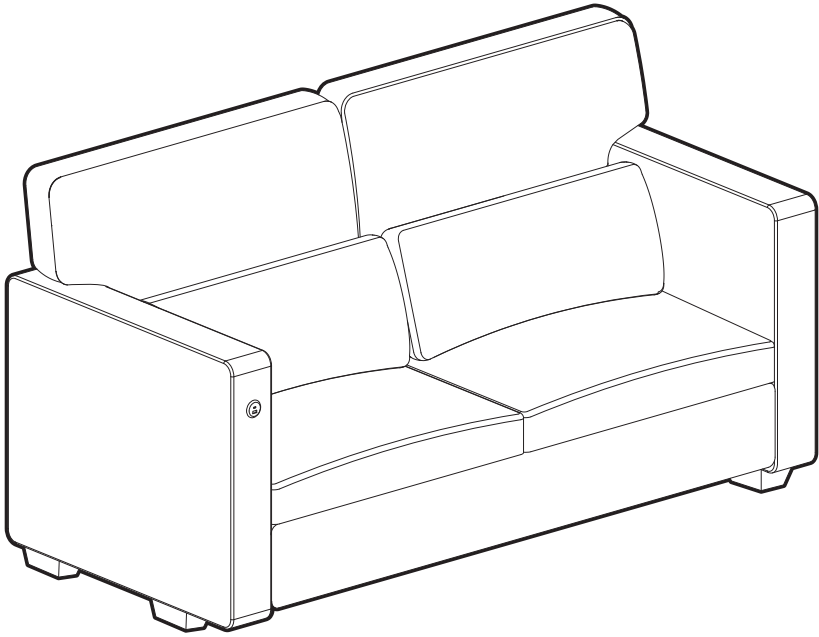

## IMPORTANT!

Product ships in  
TWO PACKAGES.  
PACKAGES may  
arrive separately.

The cushions ship vacuum sealed. To restore their original shape, follow the steps below.

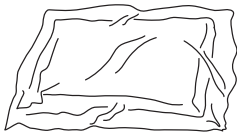

1. Carefully open the vacuum bag.

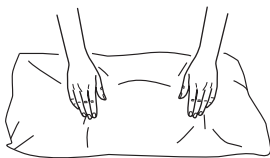

2. Press and pat to fluff the cushion.



3. Squeeze to distribute the filling evenly.

For optimal restoration, air the cushions for 72-96 hours and gently iron the fabrics at a low temperature.

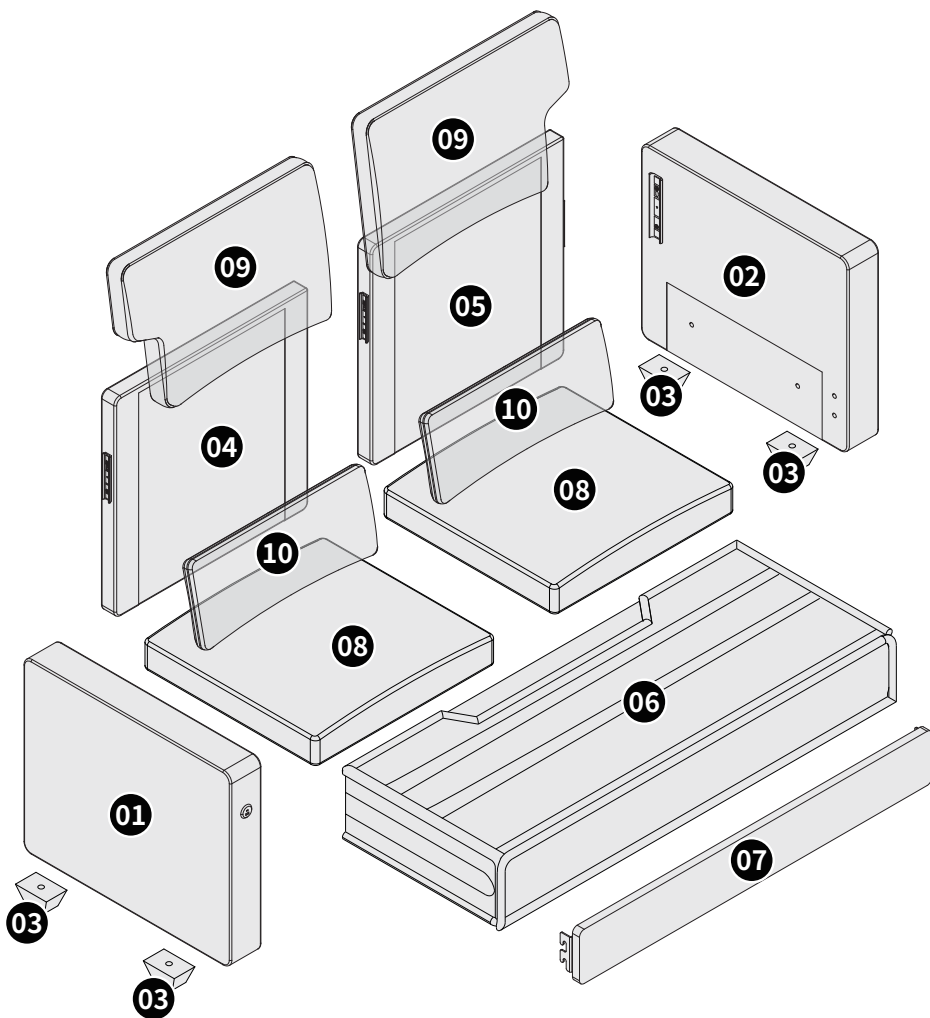

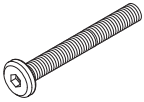
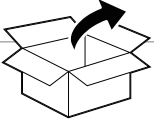
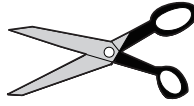
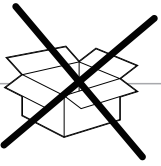

M6 x 60mm

**(A)** x 4



M8 x 25mm

**(B)** x 12

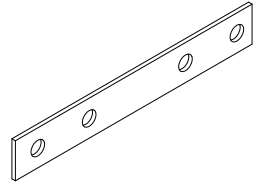

**(C)** x 1

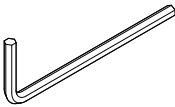

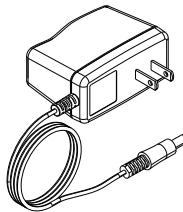

3/16" (5mm)

**(D)** x 1



**(E)** x 1

1

	
M6 x 60mm	3/16" (5mm)
(A) x 4	(D) x 1

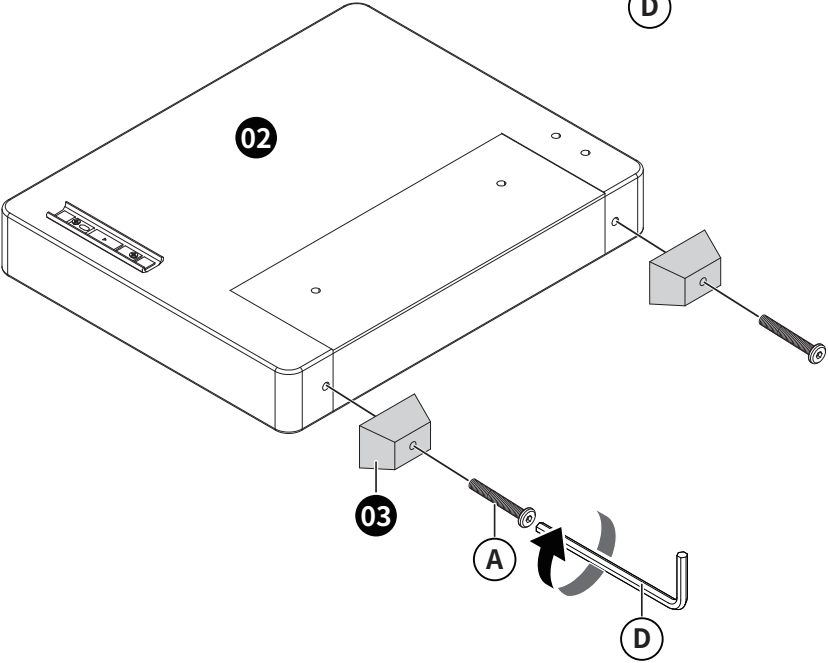
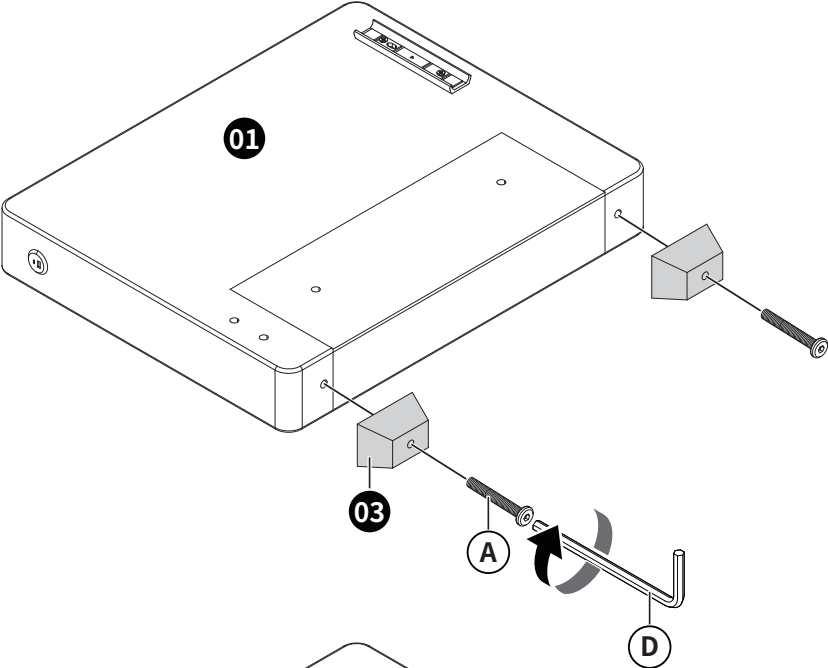

2

**Note:** Allow the bolt head to protrude 3/16" (5mm).



M8 x 25mm  
**B** x 8

3/16" (5mm)  
**D** x 1

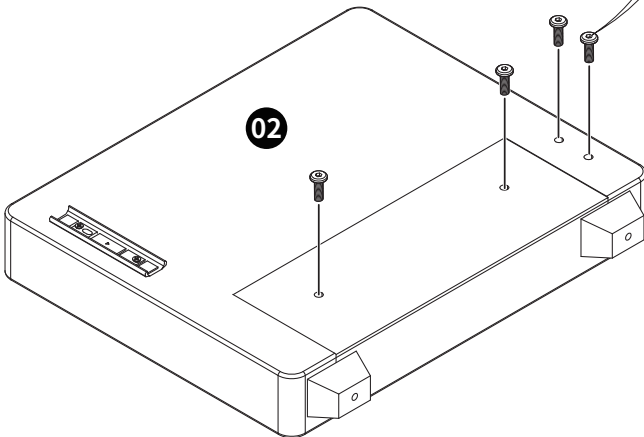
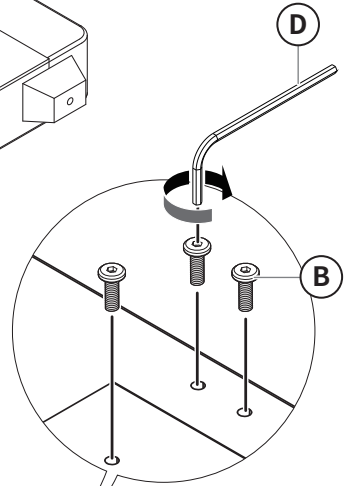
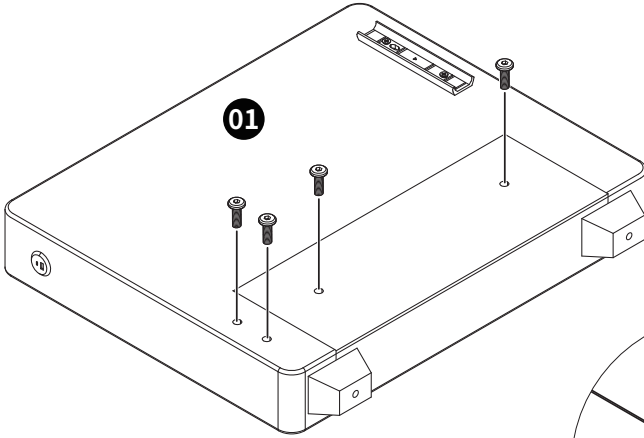

3

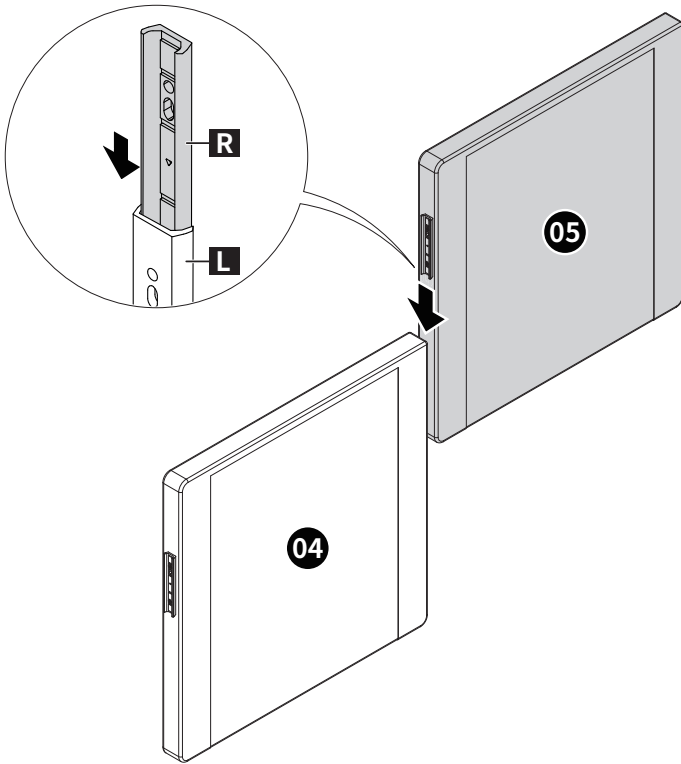

4

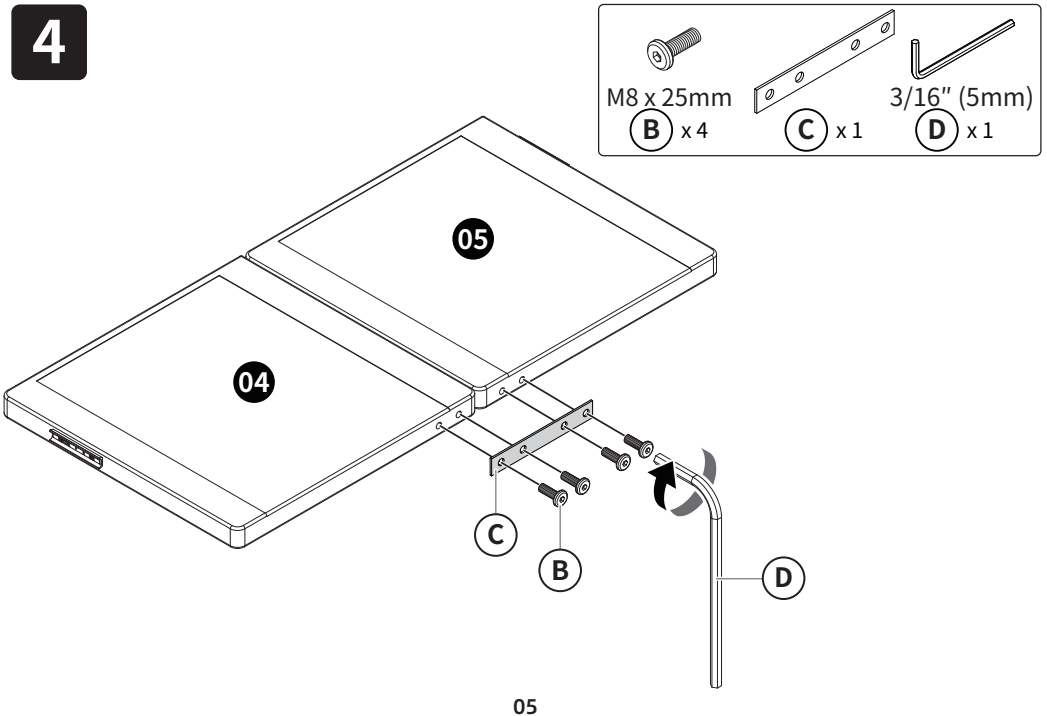

5

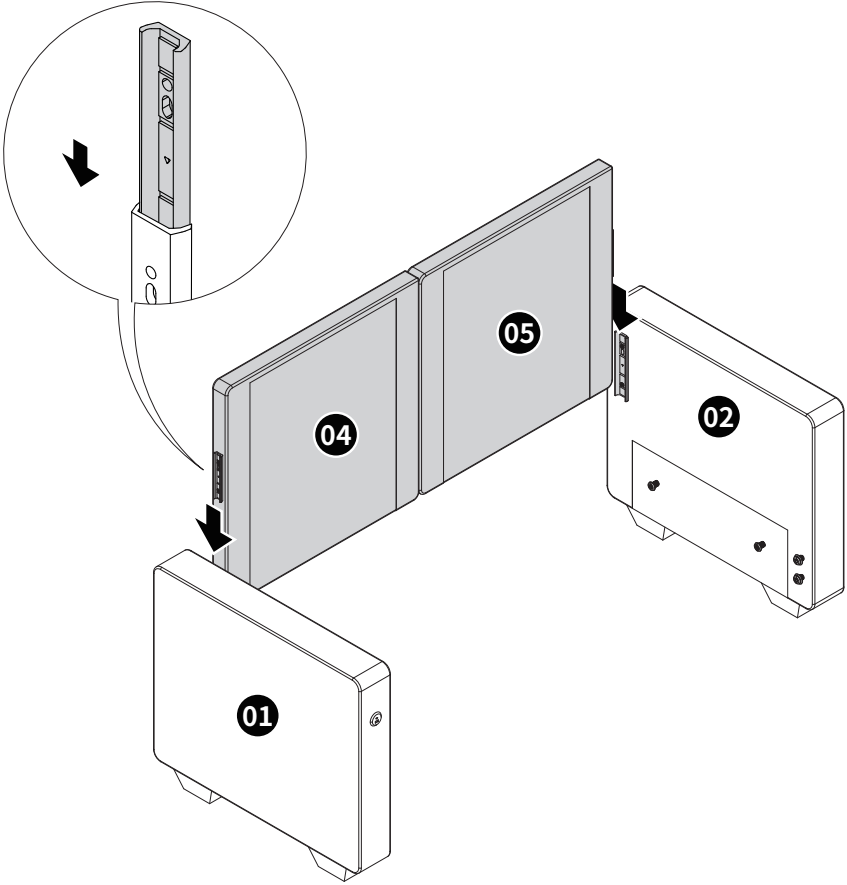
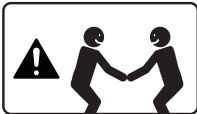

**6**

Carefully attach the base 06 to the assembled sofa frame.

First, align the inner bolts with the upper slots on both ends and snap them into place. Then, align the outer bolts with the bottom of the I-holes and snap them down into the upper holes. Ensure 4 bolts are fully seated in the holes shown before fully tightening.

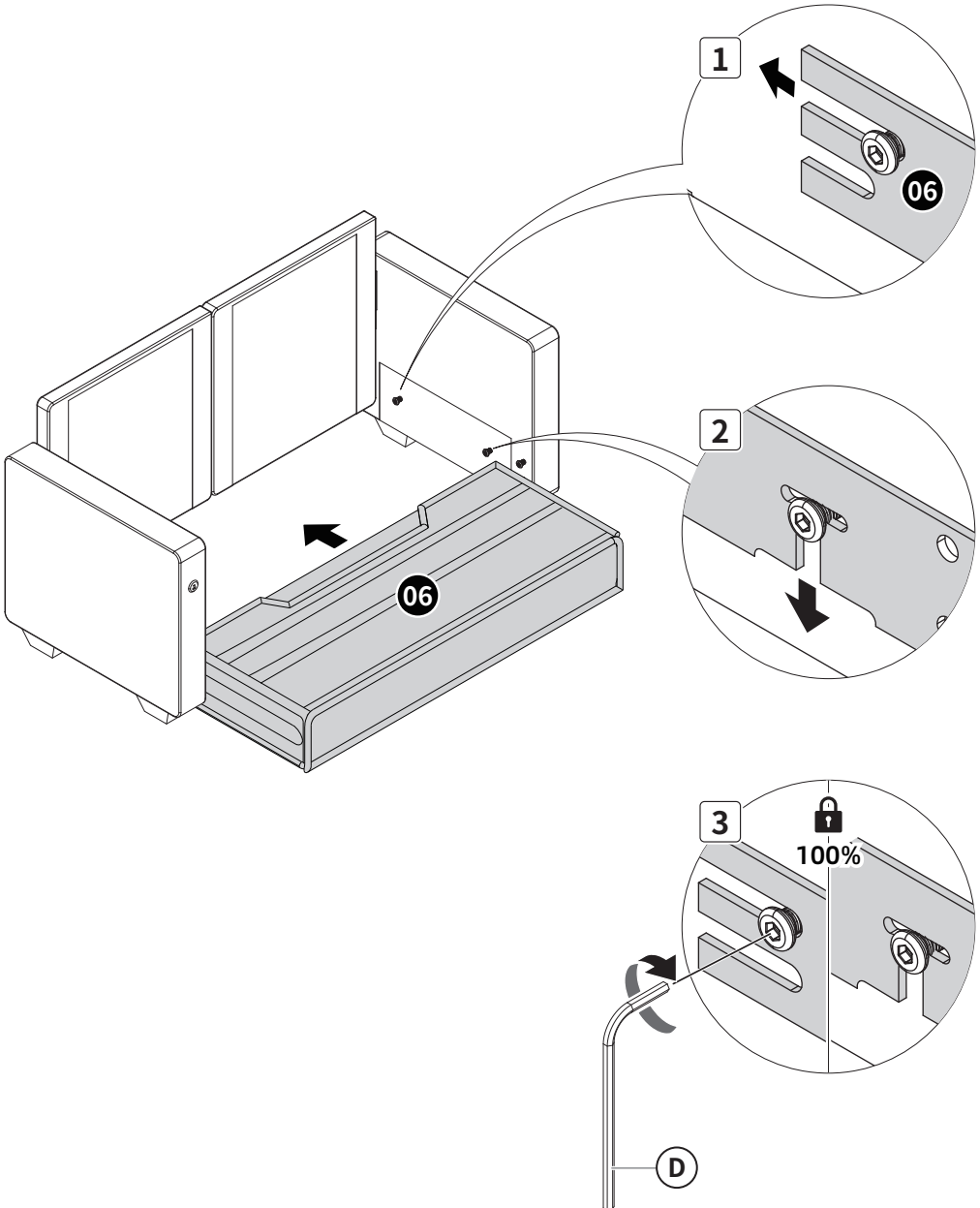
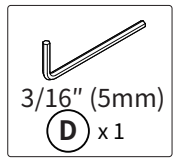
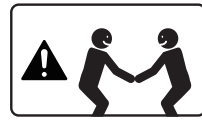

7

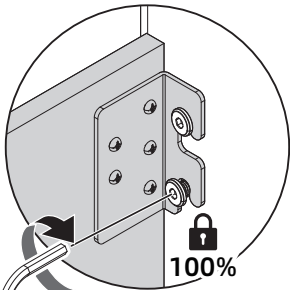
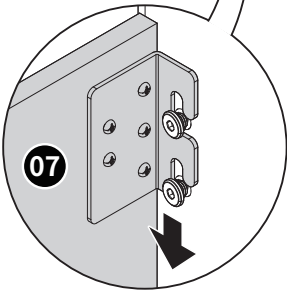
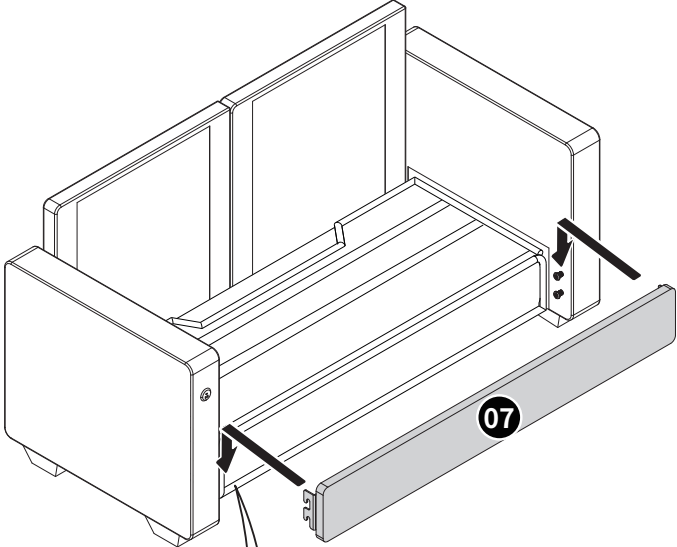
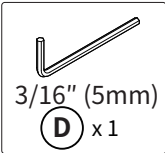

D

8

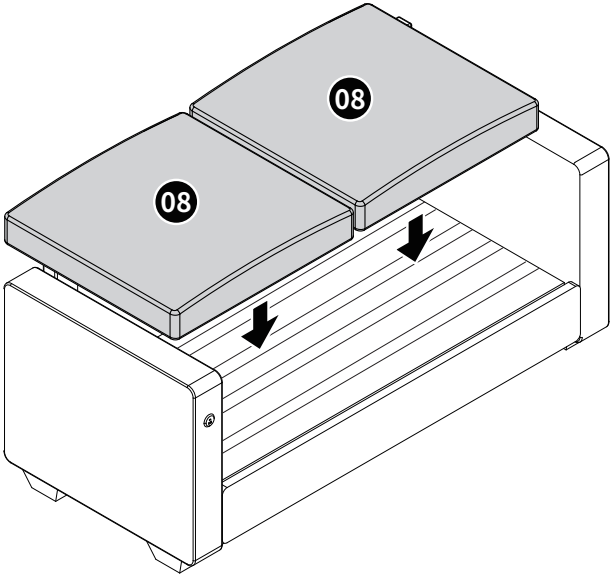

9

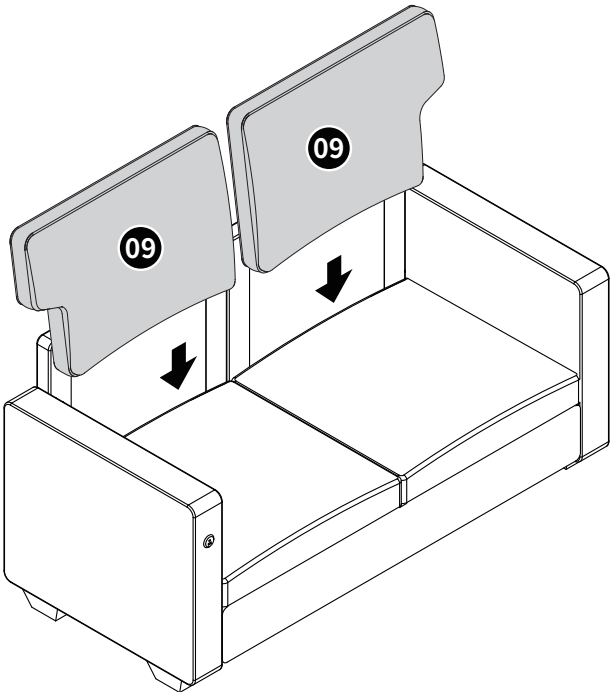

10

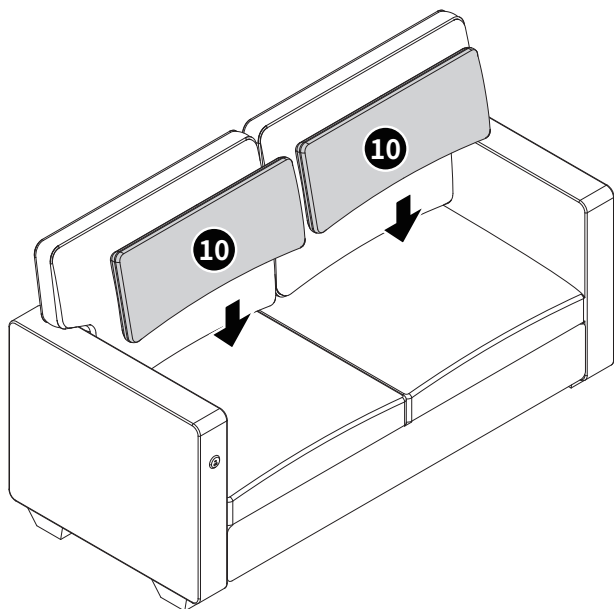

11

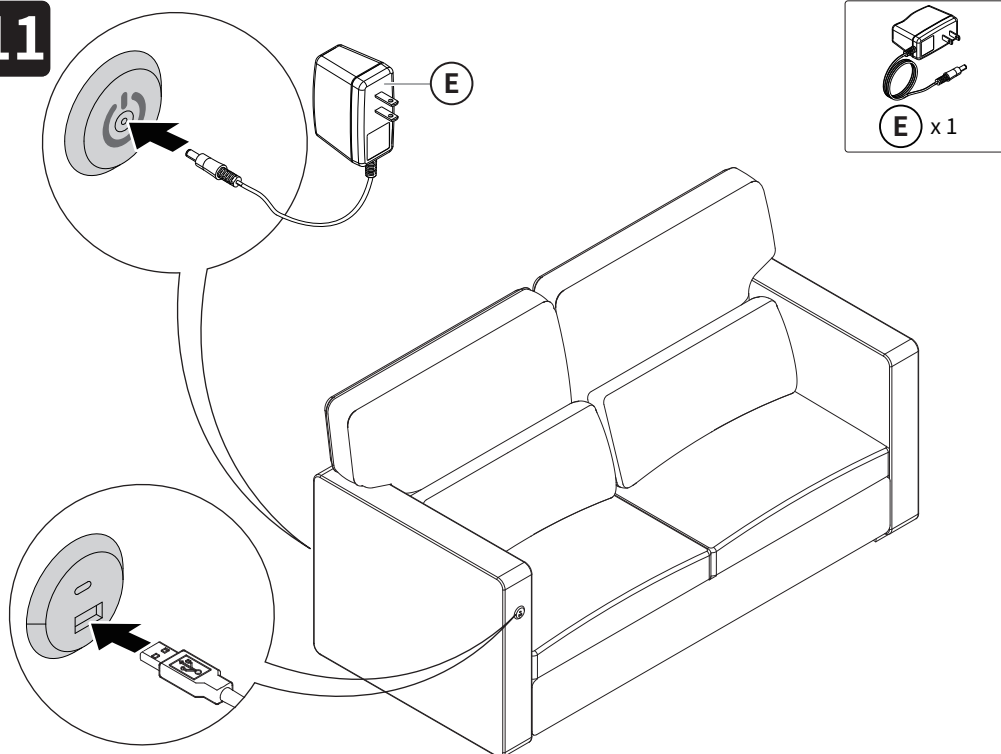

# Bed Setup

1

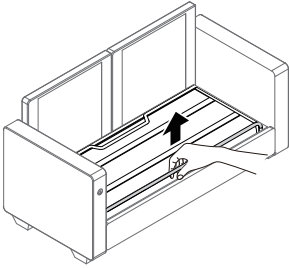

2

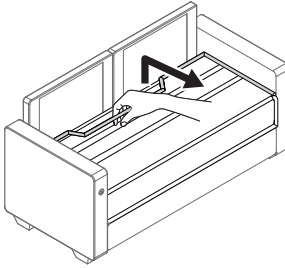

3

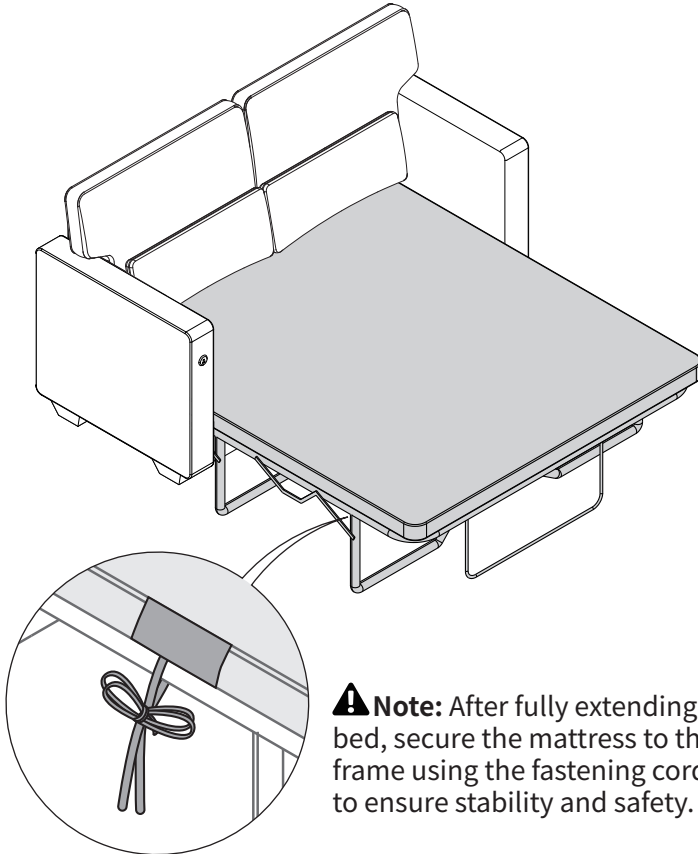
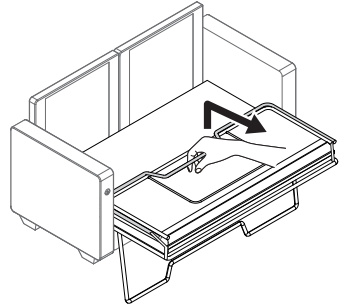

**⚠ Note:** After fully extending the bed, secure the mattress to the frame using the fastening cords to ensure stability and safety.