

# INSTRUCTION MANUAL

---

96"x28" Elevated Garden Bed

## **About Our Wood**

Our products uses only premium lumber, ensuring the safest product for your use. Although we take great care in selecting the best quality lumber available, wood is still a product of nature and susceptible to weathering which can change the appearance of your set.

What causes weathering? Does it affect the strength of my products?

One of the main reasons for weathering is the effects of water (moisture); the moisture content of the wood at the surface is different than the interior of the wood. As the climate changes, moisture moves in or out of the wood, causing tension which can result in checking and or warping. You can expect the following due to weathering. These changes will not affect the strength of the product:

1. Checking is surface cracks in the wood along the grain.
2. Warping results from any distortion (twisting, cupping) from the original plane of the board and often happens from rapid wetting and drying of the wood.
3. Fading happens as a natural change in the wood color as it is exposed to sun-light and will turn a grey over time.

How can I reduce the amount of weathering to my products ?

Sunlight will break down the wood or coating, applying a water repellent or stain on a yearly basis is important maintenance. (see your local stain and paint supplier for a recommended product)

1

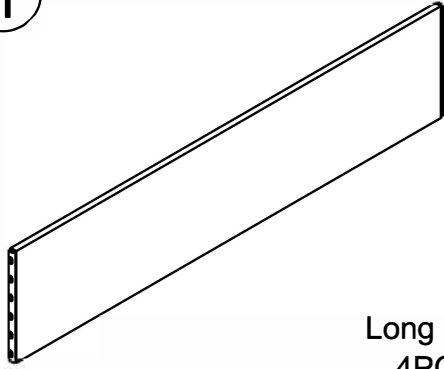

Long Panel  
4PCS

2

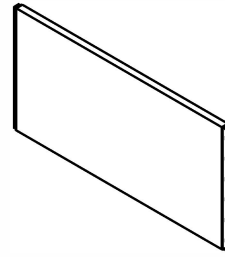

Short Panel  
3PCS

3

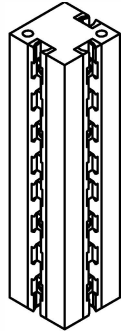

Middle Leg  
2PCS

4



End Leg  
4PCS

5

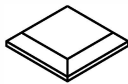

Leg Cap  
6PCS



Start the Assembly Where You Want to Used the Garden Bed



Ensure the Products Sited on Level Ground

1

Slide Four End Legs and Two Middle Legs into Short Panels



Make Sure all the Holes for the Cap FACE UP

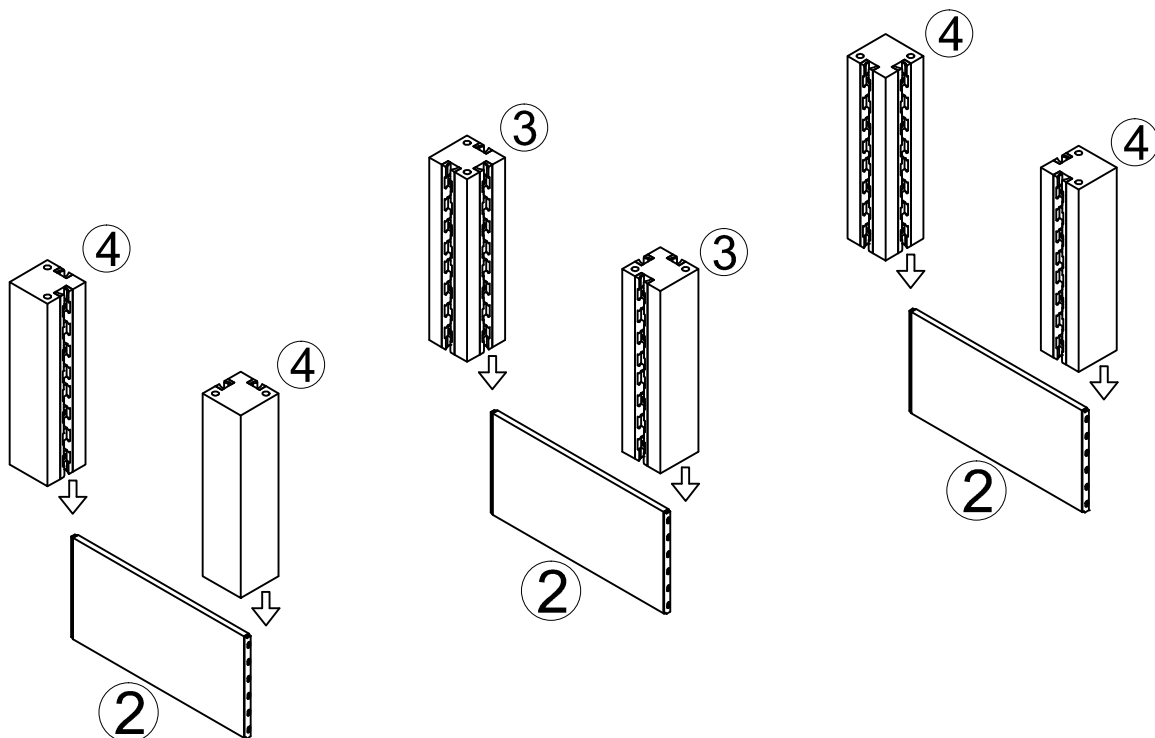

2

Slide Four Long Panels into the Legs

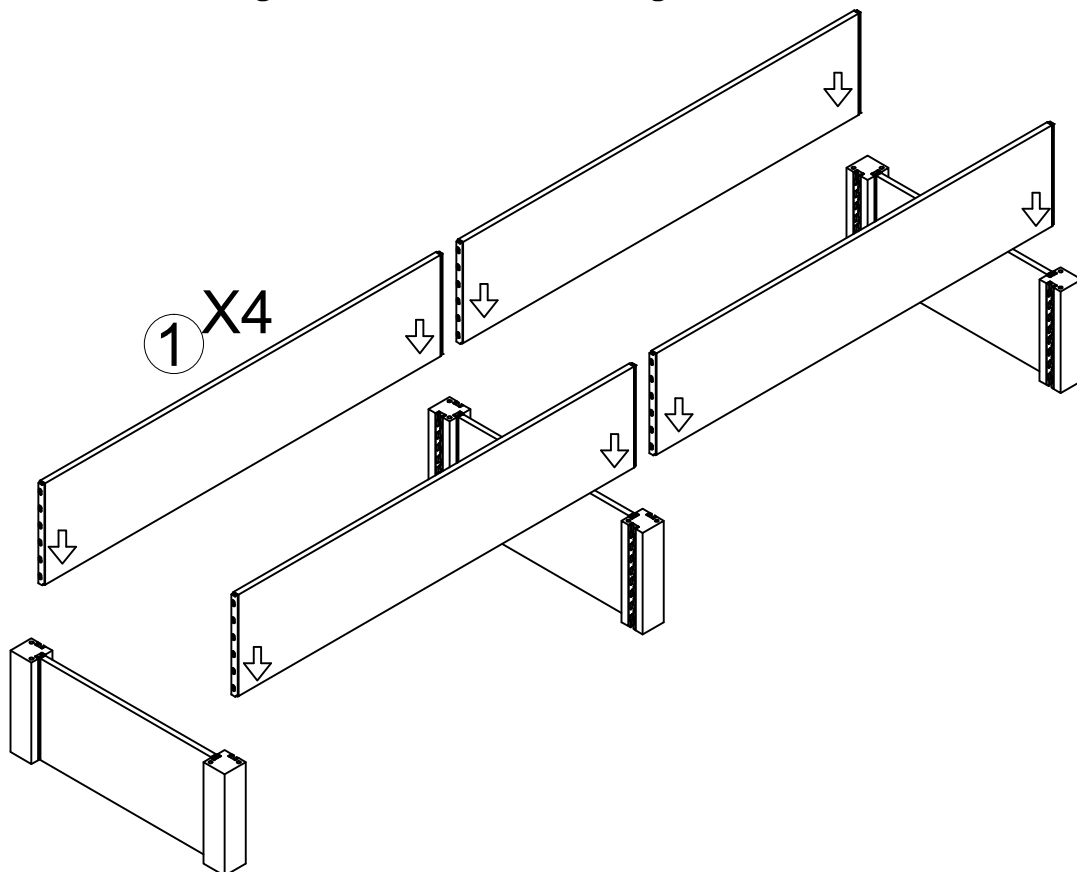

3 Put Six Leg Caps into the Legs

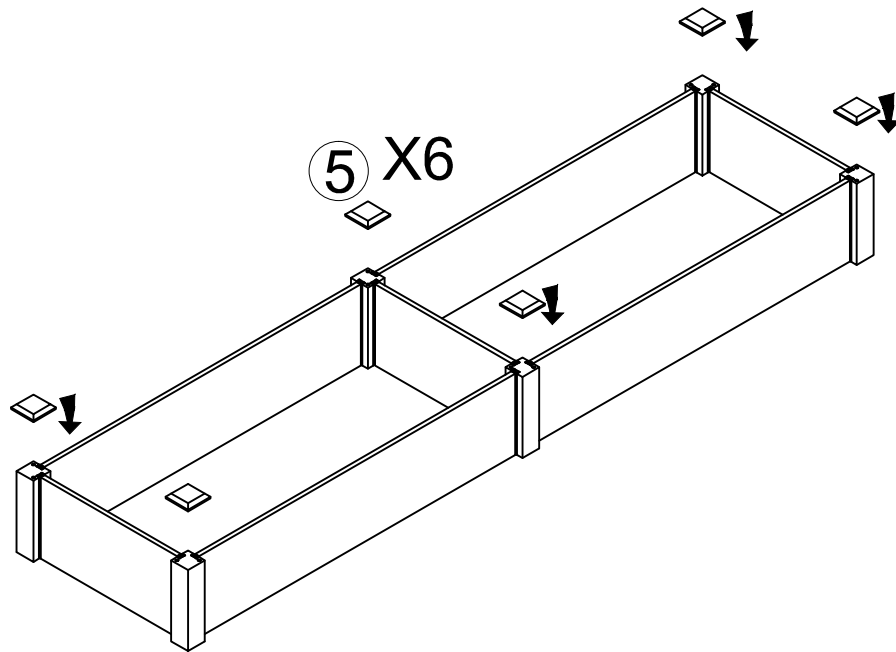

4

