

www.FlowWall.com

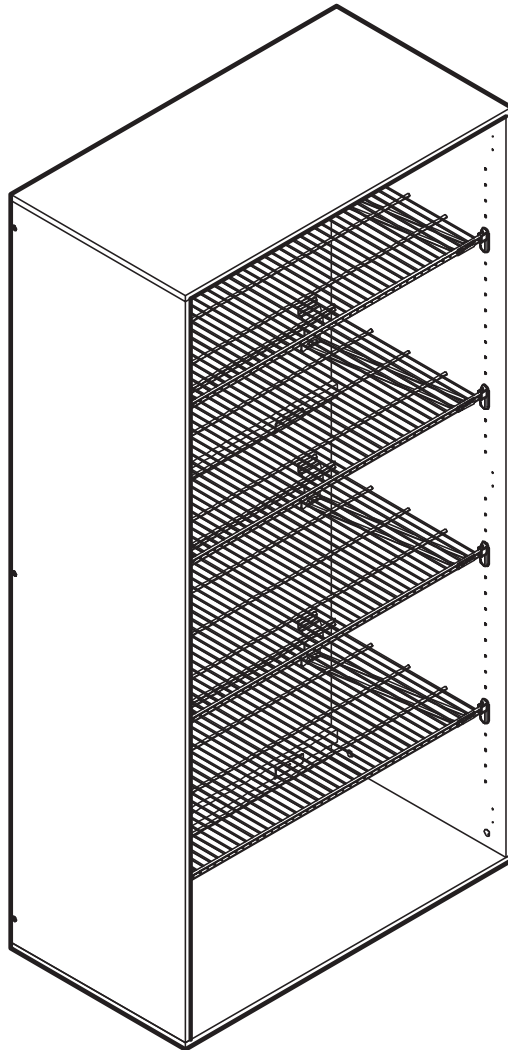

model number:

FWC-C04-G

Jumbo Cabinet Body

Distributed by:

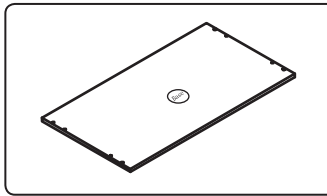

RST Brands / 1775 West 2300 South / Salt Lake City, Utah 84119
Ph: 877.924.2090 / www.rstbrands.com
Flow Wall is a registered trademark of Red Star Traders, LLC

Step 1.
Parts List - Review this parts list and reference for future assembly steps. If you find any parts are missing, please contact Flow Wall via phone or email.

1 Base
x1
Note: Thicker Waffle Board

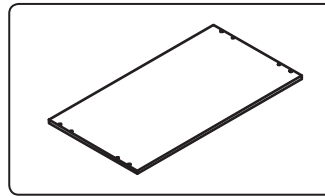

2 Top
x1

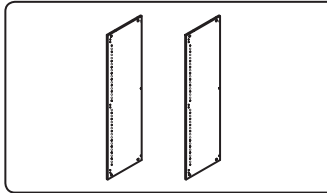

3 Sides
x2

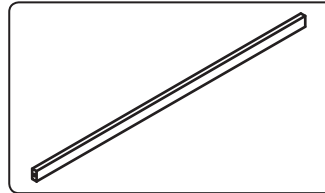

4 Spanner
x3

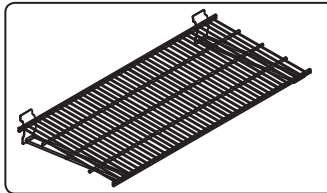

5 Metal Shelf
x4

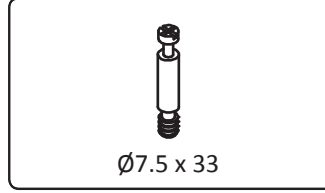

A Post
x8

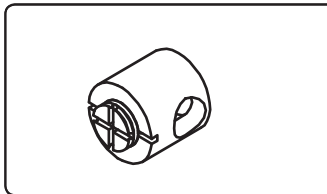

B Cam
x8

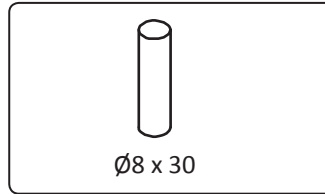

C Wood Dowel
x8

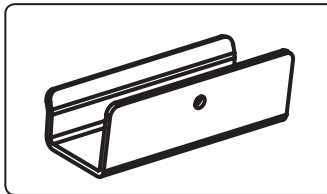

D Spanner Bracket
x6

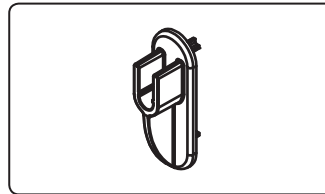

E Molded Clip
x8

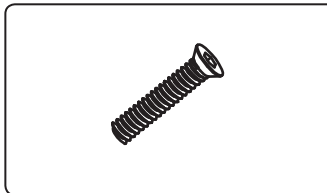

F Screw
x6

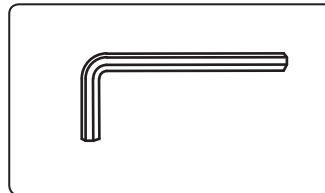

G Allen Wrench
x1

Step 2.

Mount Posts - ScREW post into reciever holes on Top & Bottom Panel.

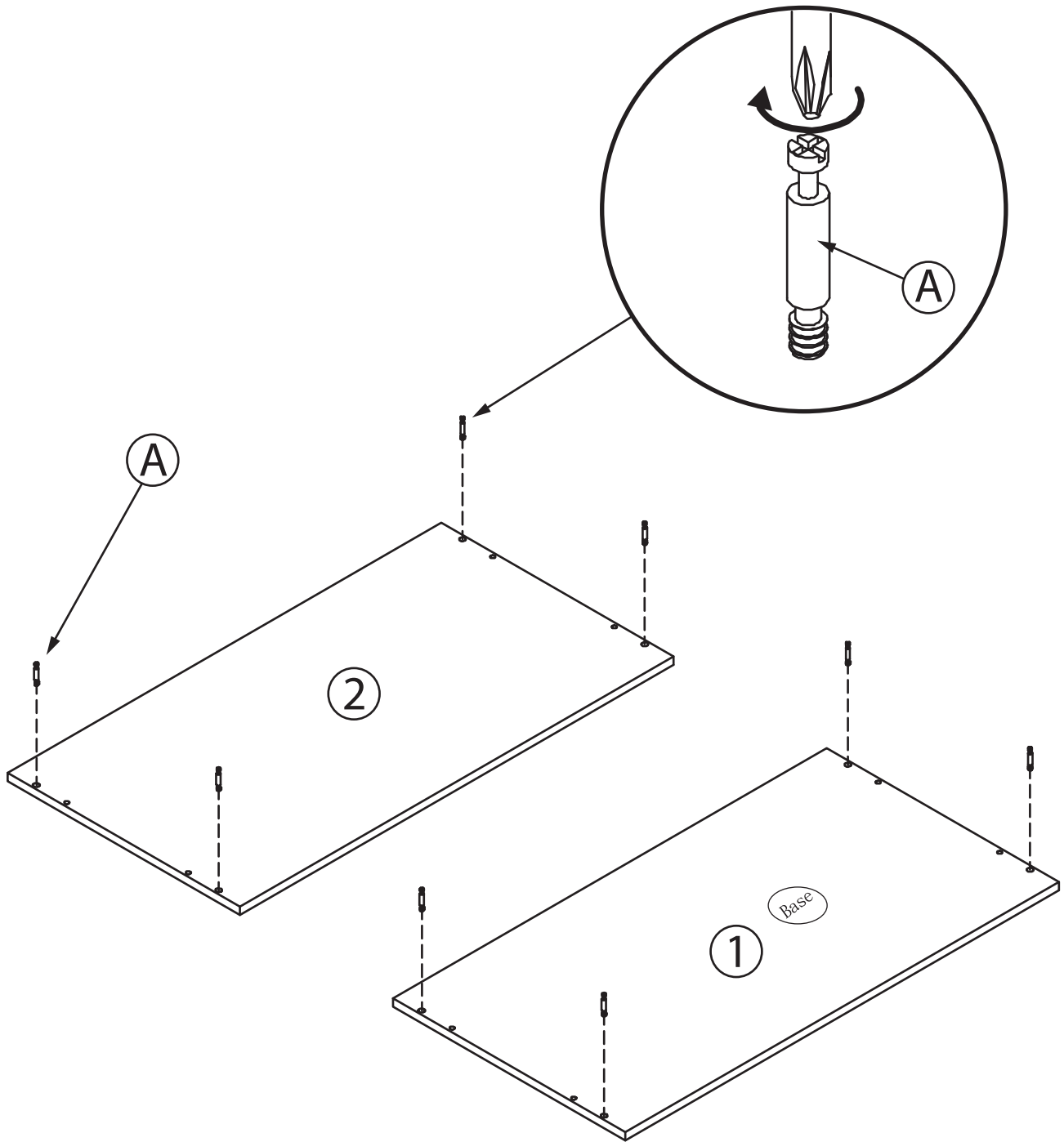



Step 3. Side Panel - Glue and insert dowels into side panel.

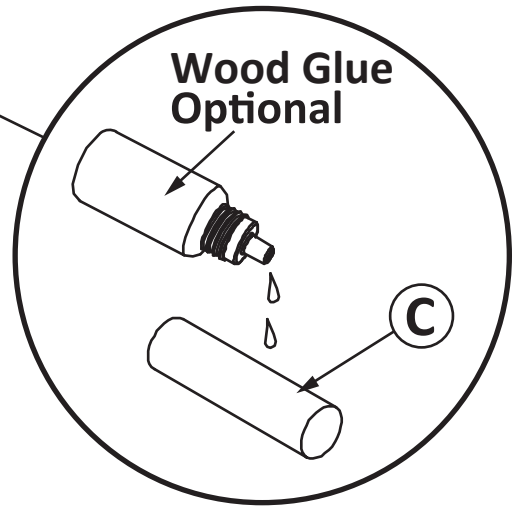
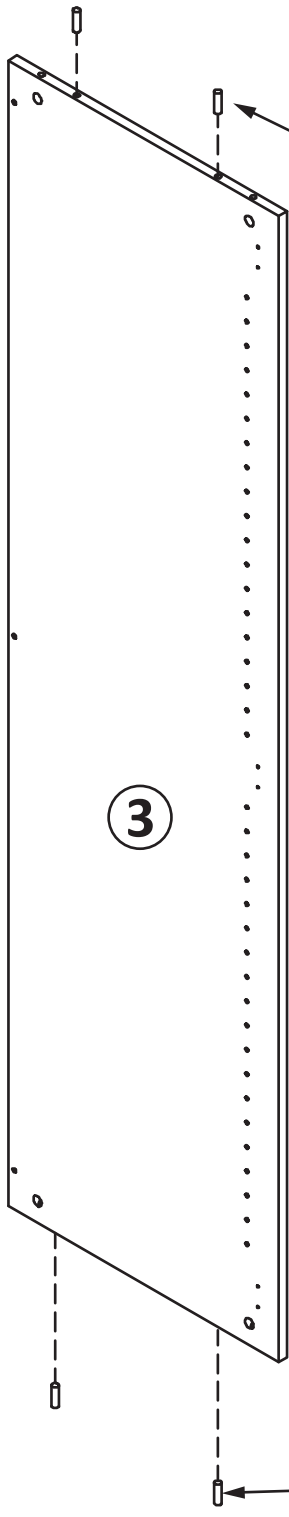
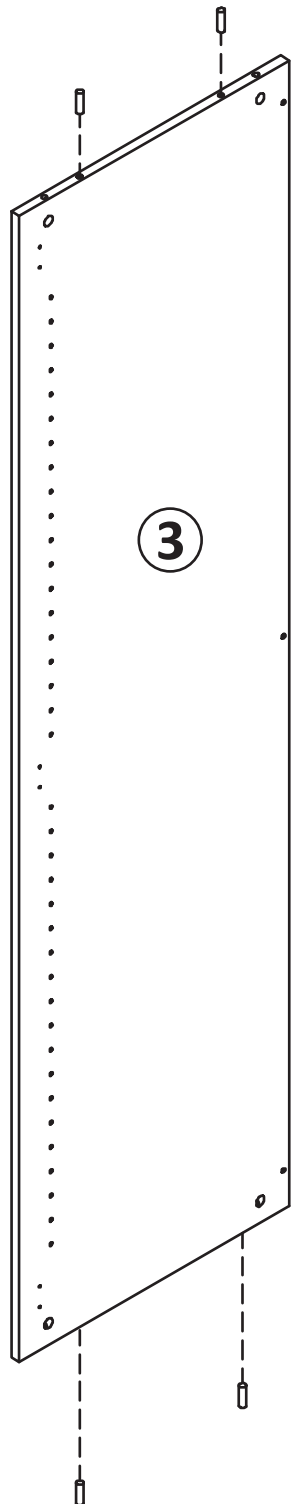



Step 4.

Assemble top/ bottom to side panels. Insert Cams (B) into holes on sides. Slide top and bottom panel together. Tighten Cams.

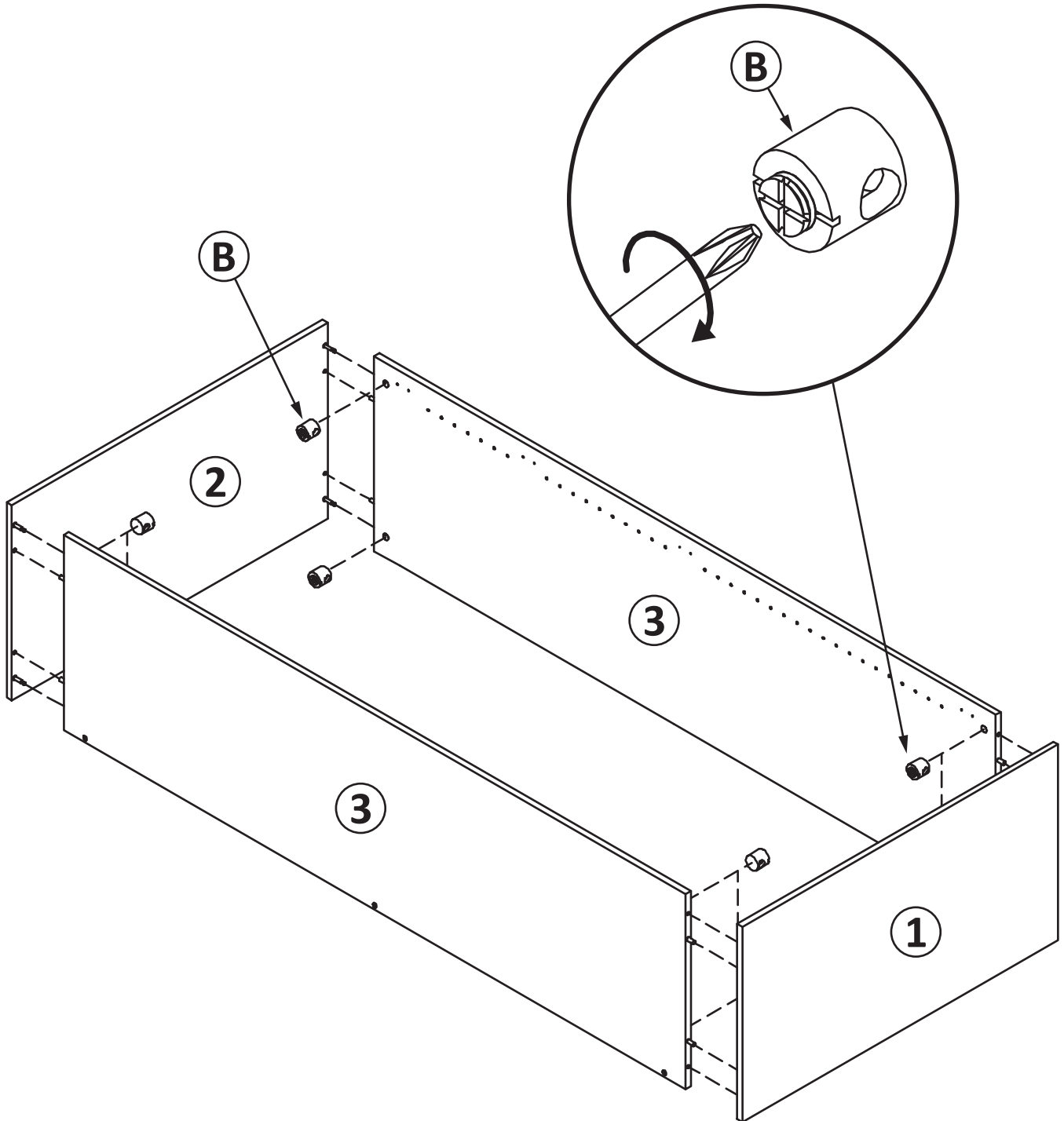

Step 5.

Spanner Bar - Screw Spanner Bars into side panel.

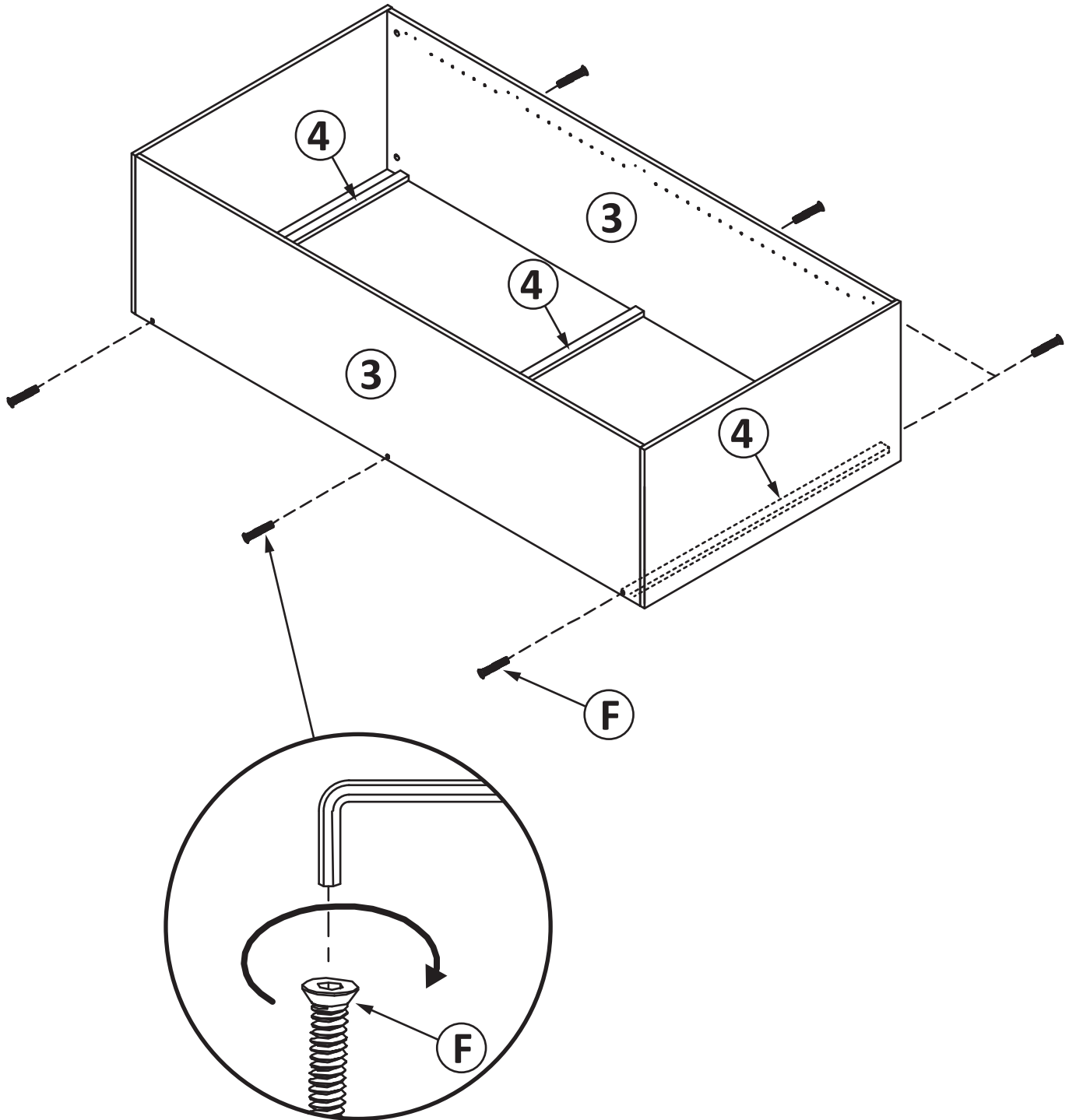



Step 6.

Hang the Cabinet - Hang the cabinet on the spanner brackets. After hanging, the cabinet can be adjusted side to side by sliding shell and brackets.

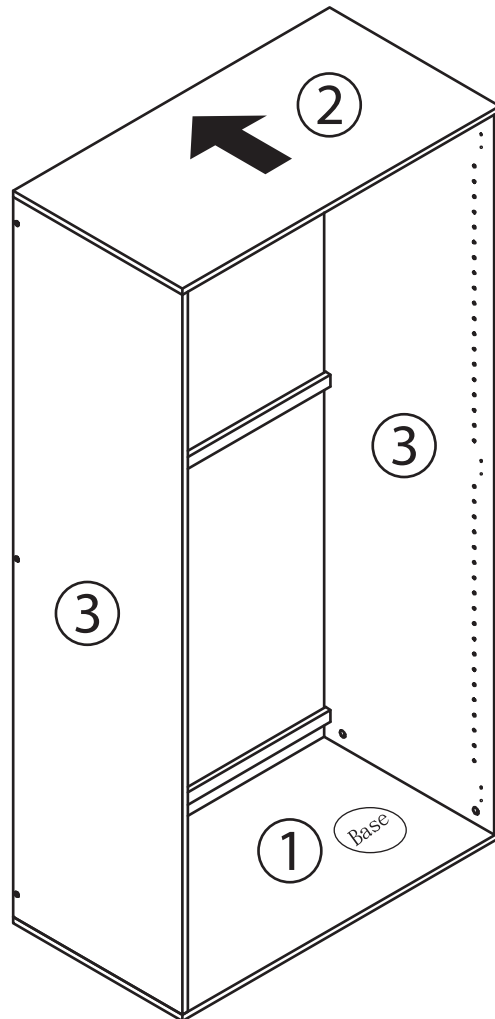
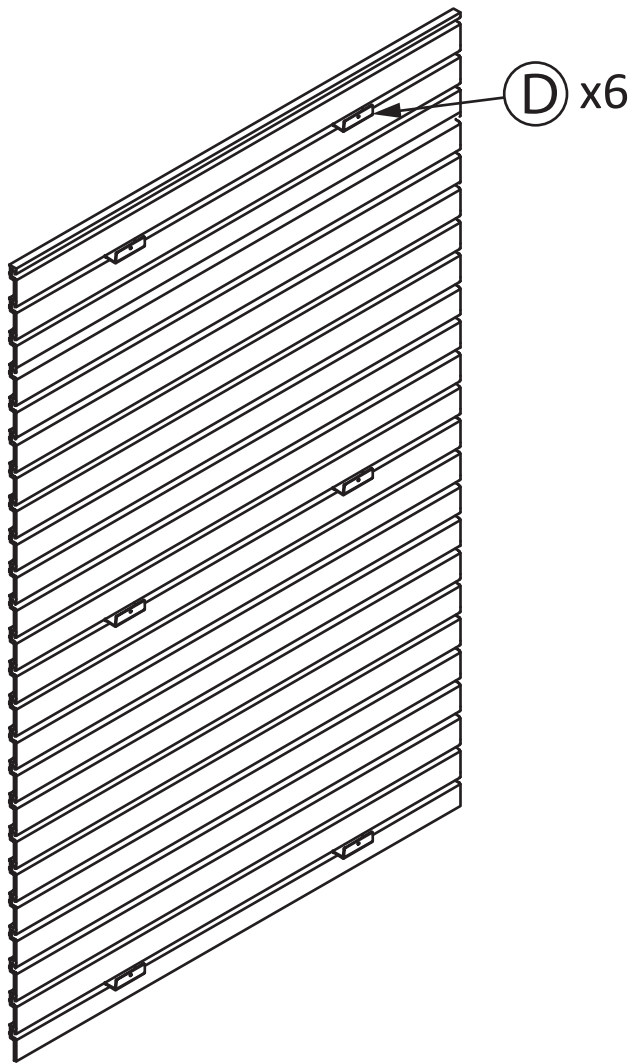
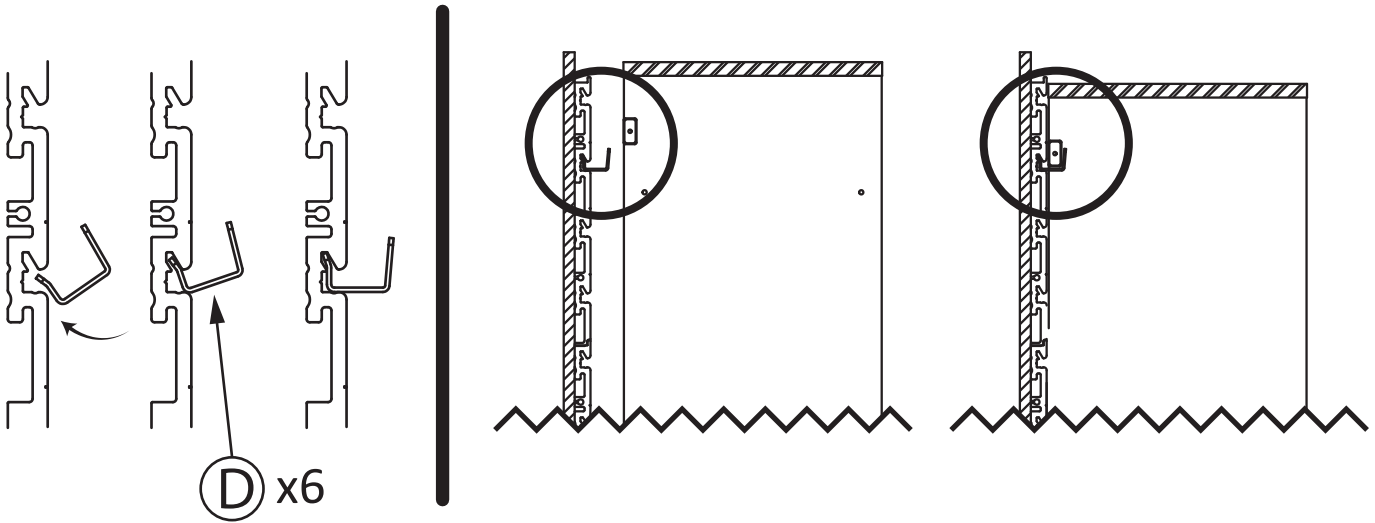



Step 7.

Hang Shelf - Attach molded shelf clip onto cabinet interior.

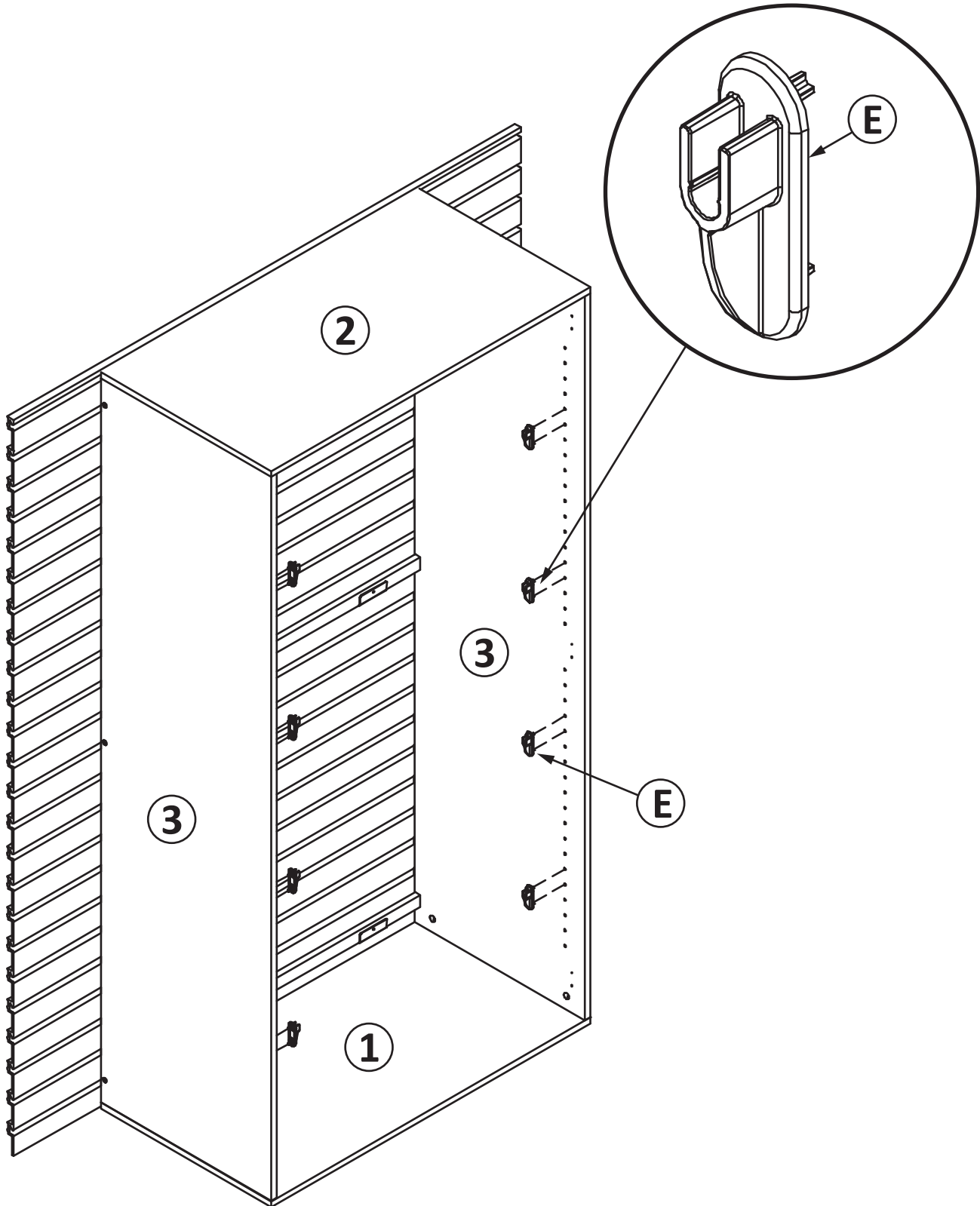



Step 8.

Hang Shelves - Attach shelf onto Flow Wall panel and slide down to molded shelf clip.

