

Assembly Instructions

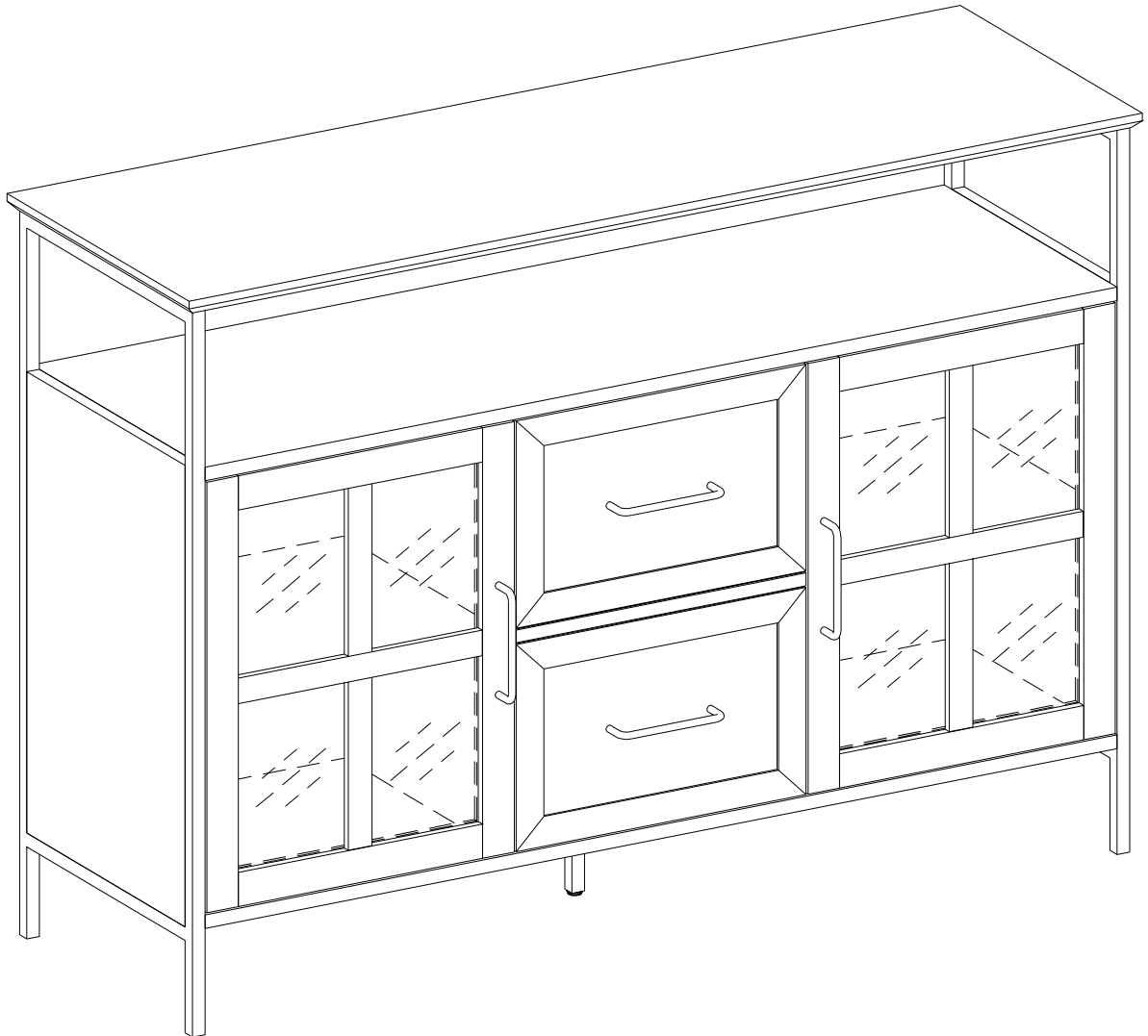

General Assembly Guidelines

- I. Ensure that all parts and hardware are available before beginning assembly.
- II. Follow each step carefully to ensure the proper assembly of this product.
- III. Two people are recommended for ease in the assembly of this product.
- IV. The three main types of hardware used to assemble this product are: wood dowels, screws and bolts.
- V. The provided glue is to secure wood dowels in place. When first inserting dowels, locate the appropriate hole for the dowel, place a small amount of glue in the hole and insert the dowel. Wipe away excess glue immediately.

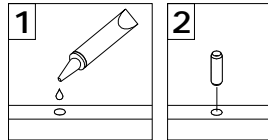

In future assembly steps when dowels are necessary to attach assembly parts together, place a small amount of glue on the end of the dowel before attaching parts together. Wipe away excess glue immediately.

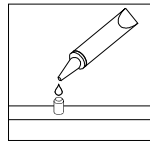

- VI. A Phillips head screwdriver is required for the assembly of this product.

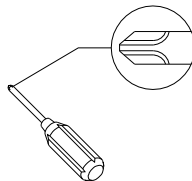

- VII. Power tools should not be used to assemble this product.

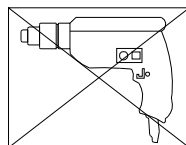

- VIII. Drill may be needed for securing product to wall.

- IX. Concealed hinges are three-way adjustable.

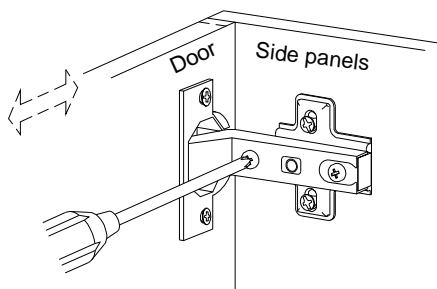

Horizontal
by screw adjustment

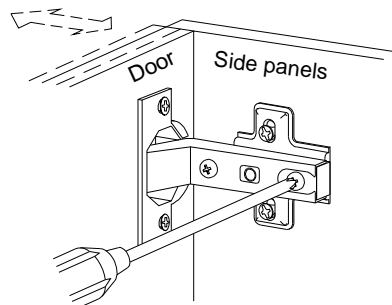

In-and-Out
by loosening the hinge-arm
mounting screw or via cam
adjustment

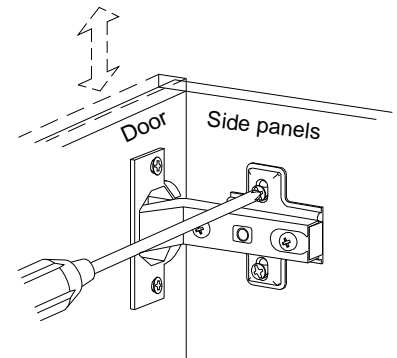





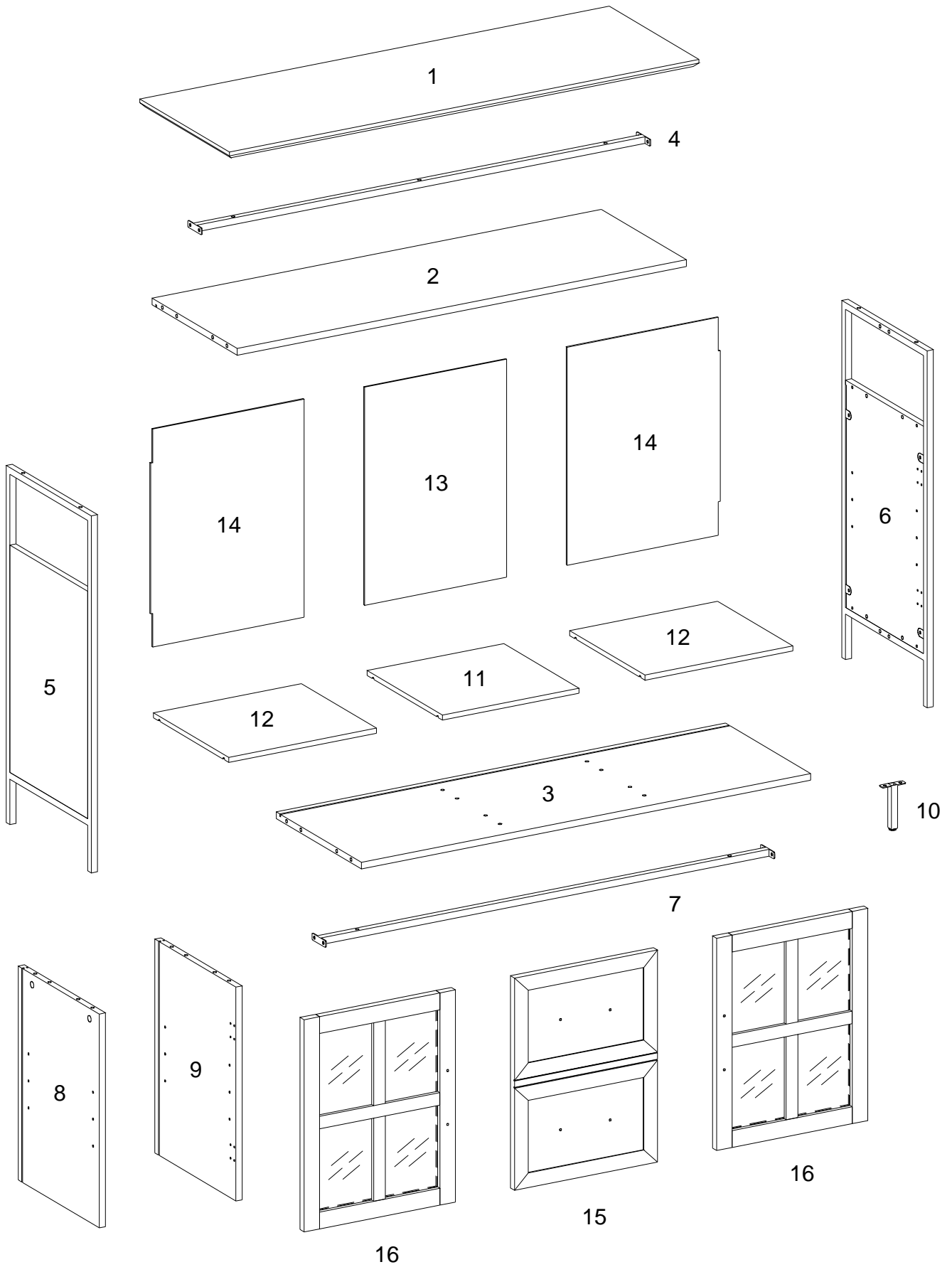





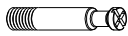









Vertical
Via slots in the mounting
plate or via cam adjustment

Parts List



Hardware List

A		Ø8x30mm	Wooden dowel	16 pcs
B		Ø15x11mm	Cam lock	12 pcs
C		Ø6x35mm	Cam bolt	12 pcs
D		Ø30mm	Sticker	12 pcs
E		Ø6x50mm	Bolt	4 pcs
F		M 4	Hex Key	1 pcs
G		Ø6x12mm	Bolt	10 pcs
H		Ø6x25mm	Bolt	9 pcs
J			Shelf support pin	12 pcs
K		Ø4x22mm	Bolt	8 pcs
L			Handle	4 pcs
M		Ø3x17mm	Screw	12 pcs
N			Plastic wedge	12 pcs
P			West hinge	2 pcs
Q			West hinge	4 pcs
R		Ø3.5x14mm	Screw	36 pcs
S			Screw	2 pcs
T			Screw	2 pcs
U			Plastic strap	2 pcs
V			Nut	2 pcs
W			Glue tube	1 pc

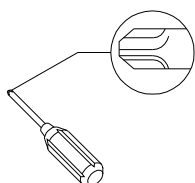

Philips head screwdriver required for assembly
(not included)

*The hardware quantities listed above are required for proper assembly.
Some extra hardware may also have been included.*

Step 1

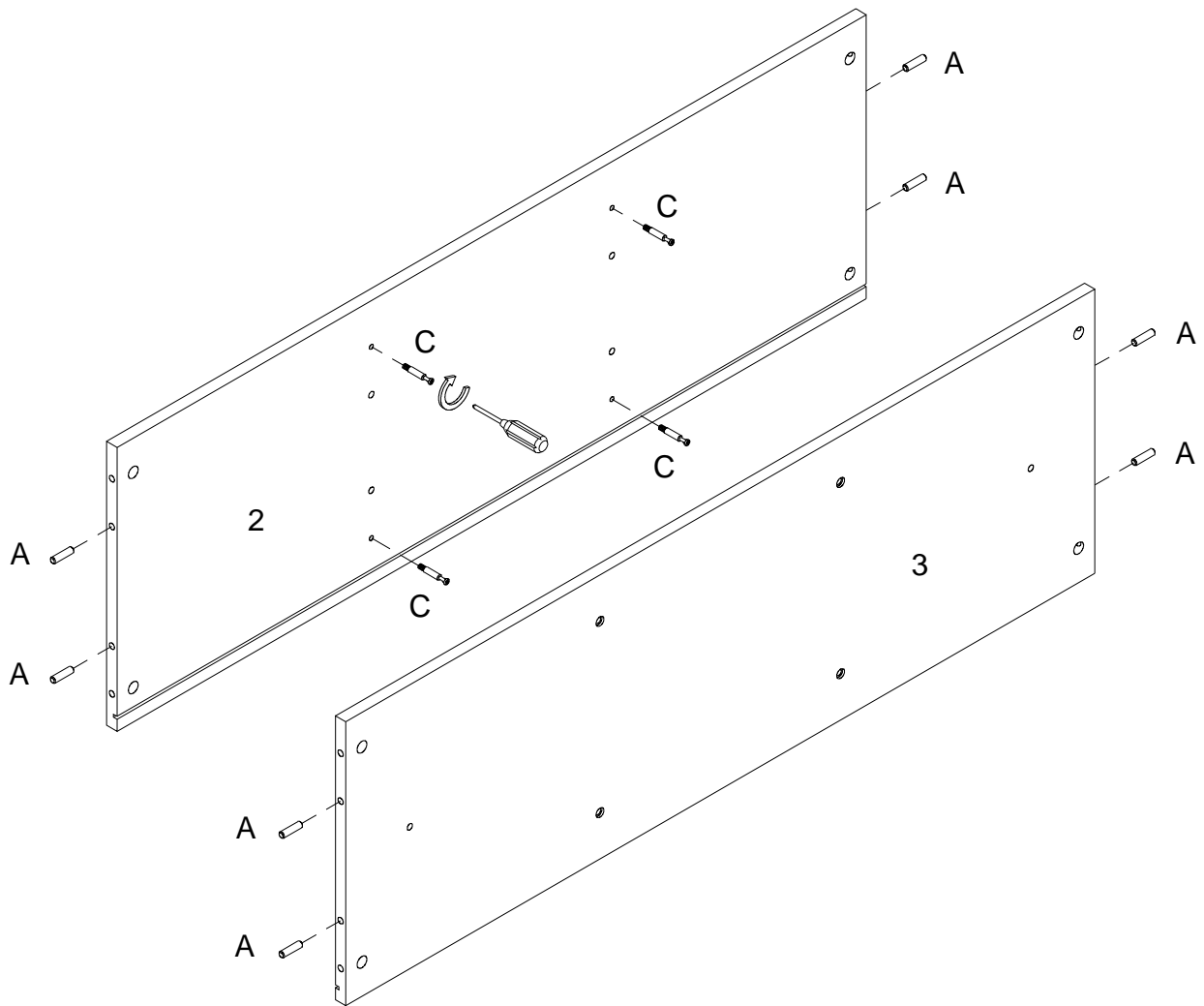

Insert wooden dowel (A) into parts (2,3), using cam bolt (C) secure part (2) with Philips head screwdriver as per diagram.

Step 2

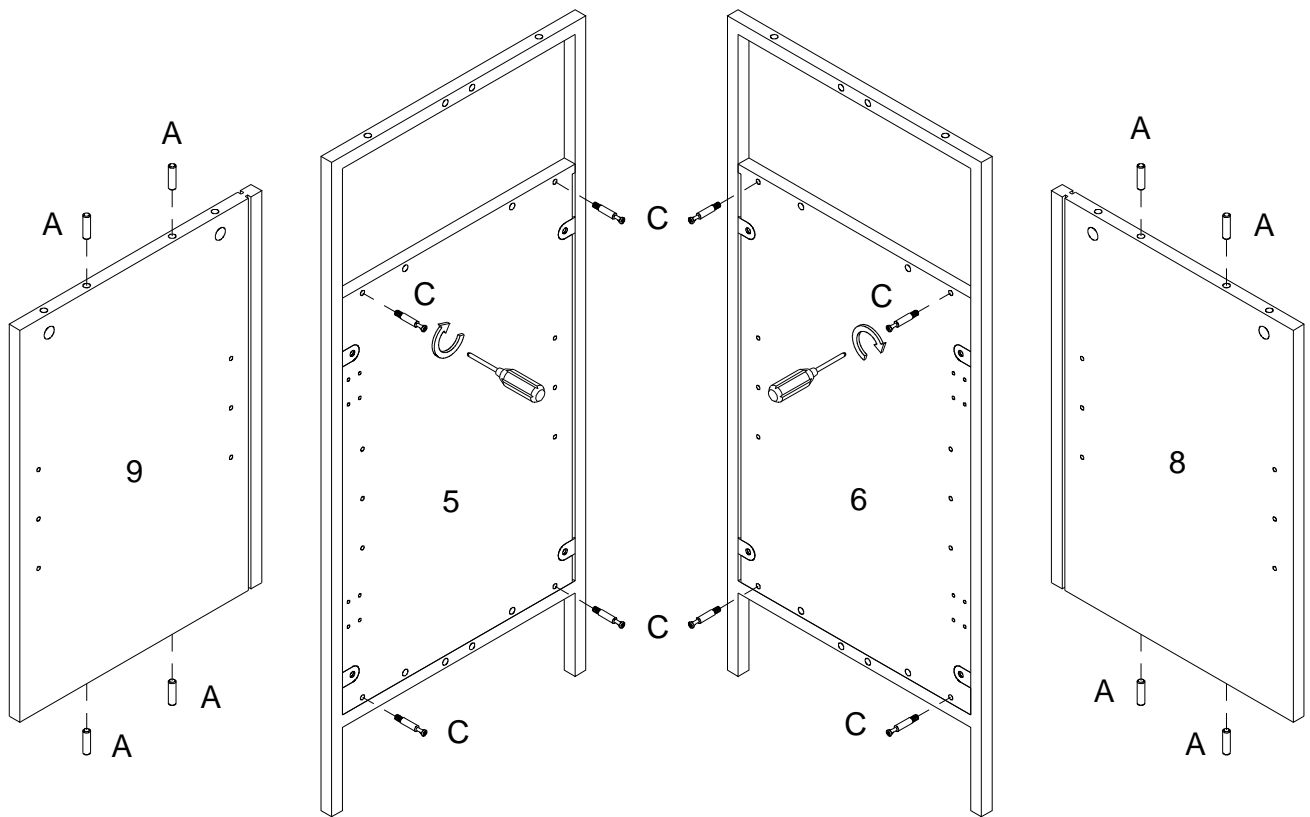

Insert wooden dowel (A) into parts (8,9), using cam bolt (C) secure parts (5,6) with Philips head screwdriver as per diagram.

Step 3

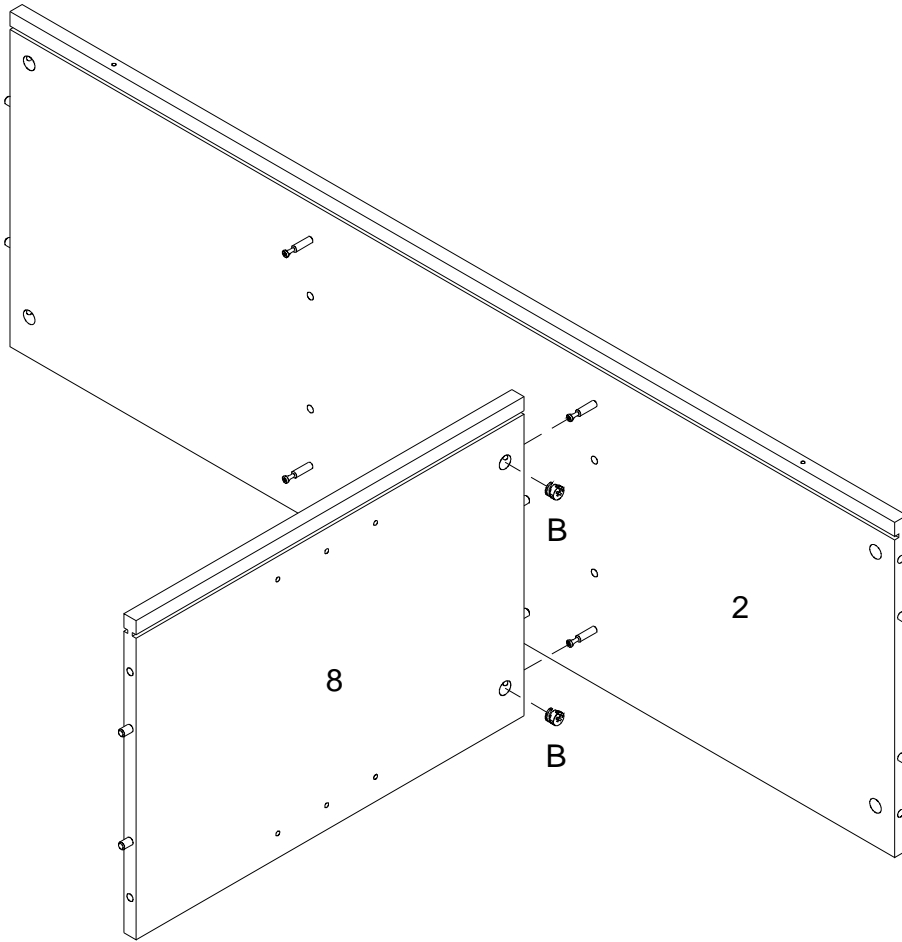
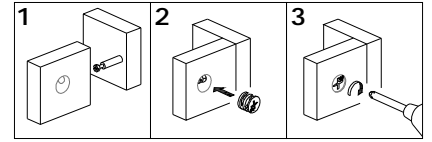

Using cam lock (B) secure part (8) to part (2) with Philips head screwdriver as per diagram.

Step 4

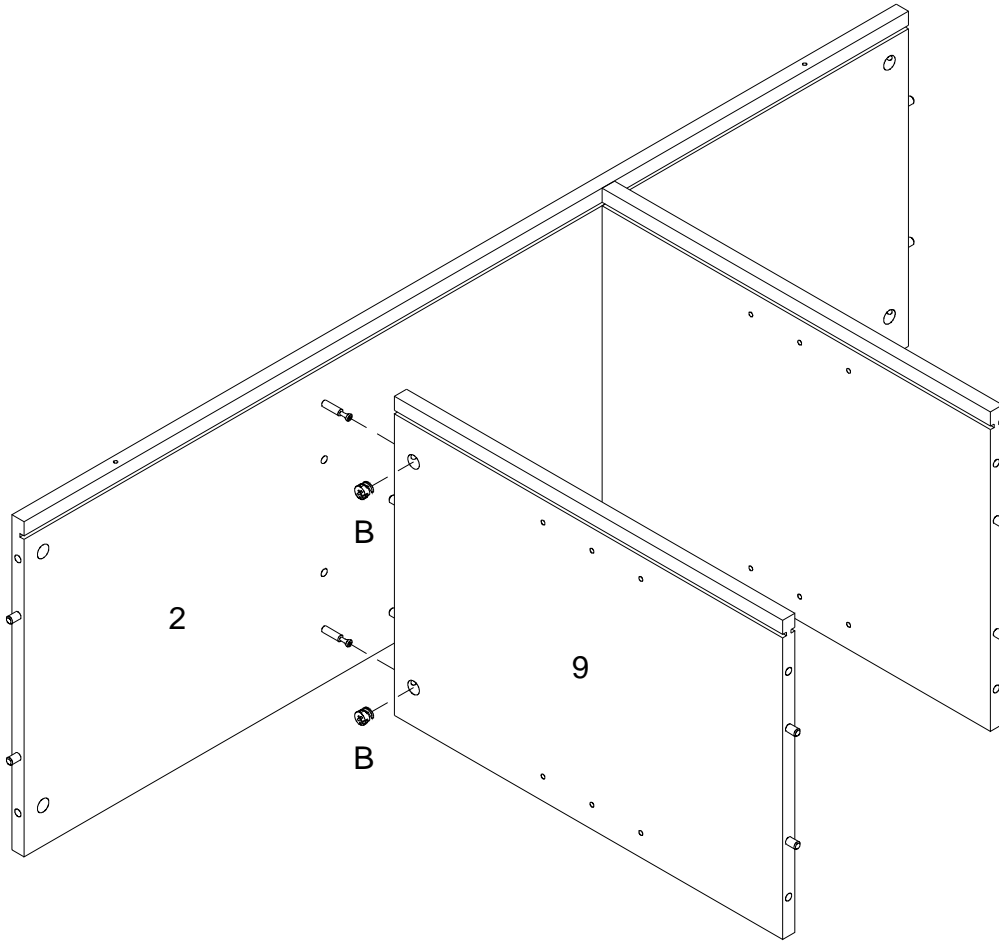
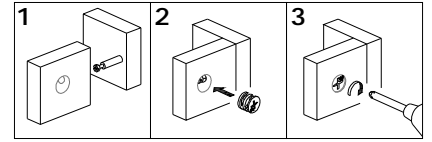

Using cam lock (B) secure part (9) to part (2) with Philips head screwdriver as per diagram.

Step 5

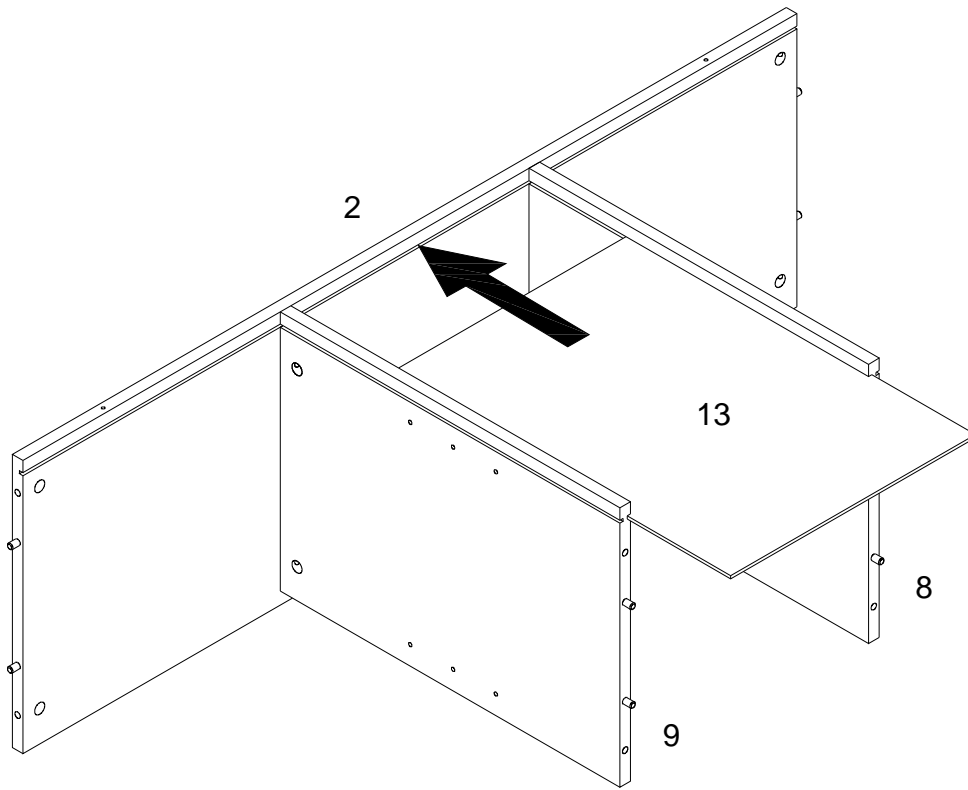

Insert part (13) into parts (2,8,9) as per diagram.

Step 6

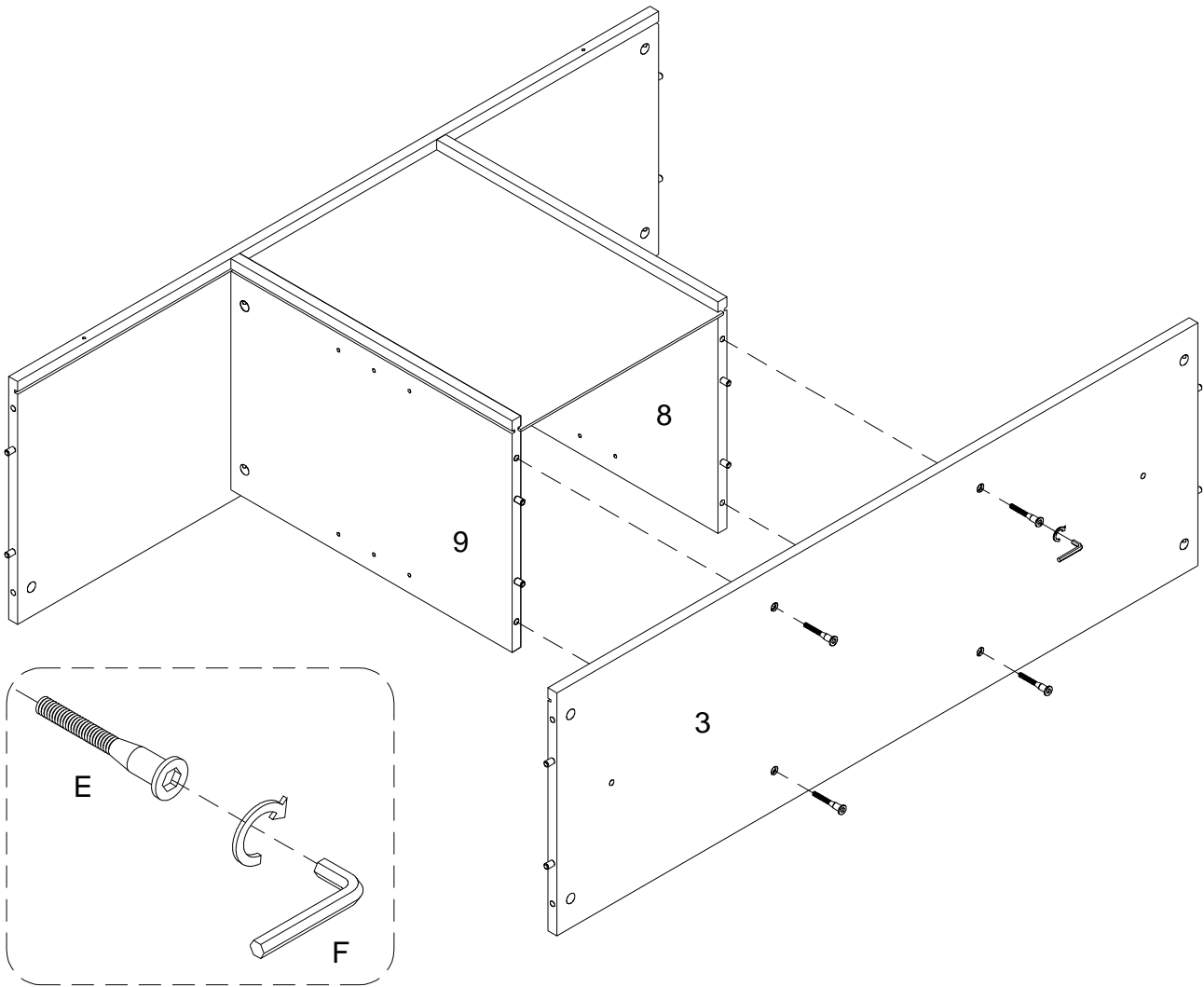

Using bolt (E) secure part (3) into parts (8,9) with hex key (F) as per diagram.

Step 7

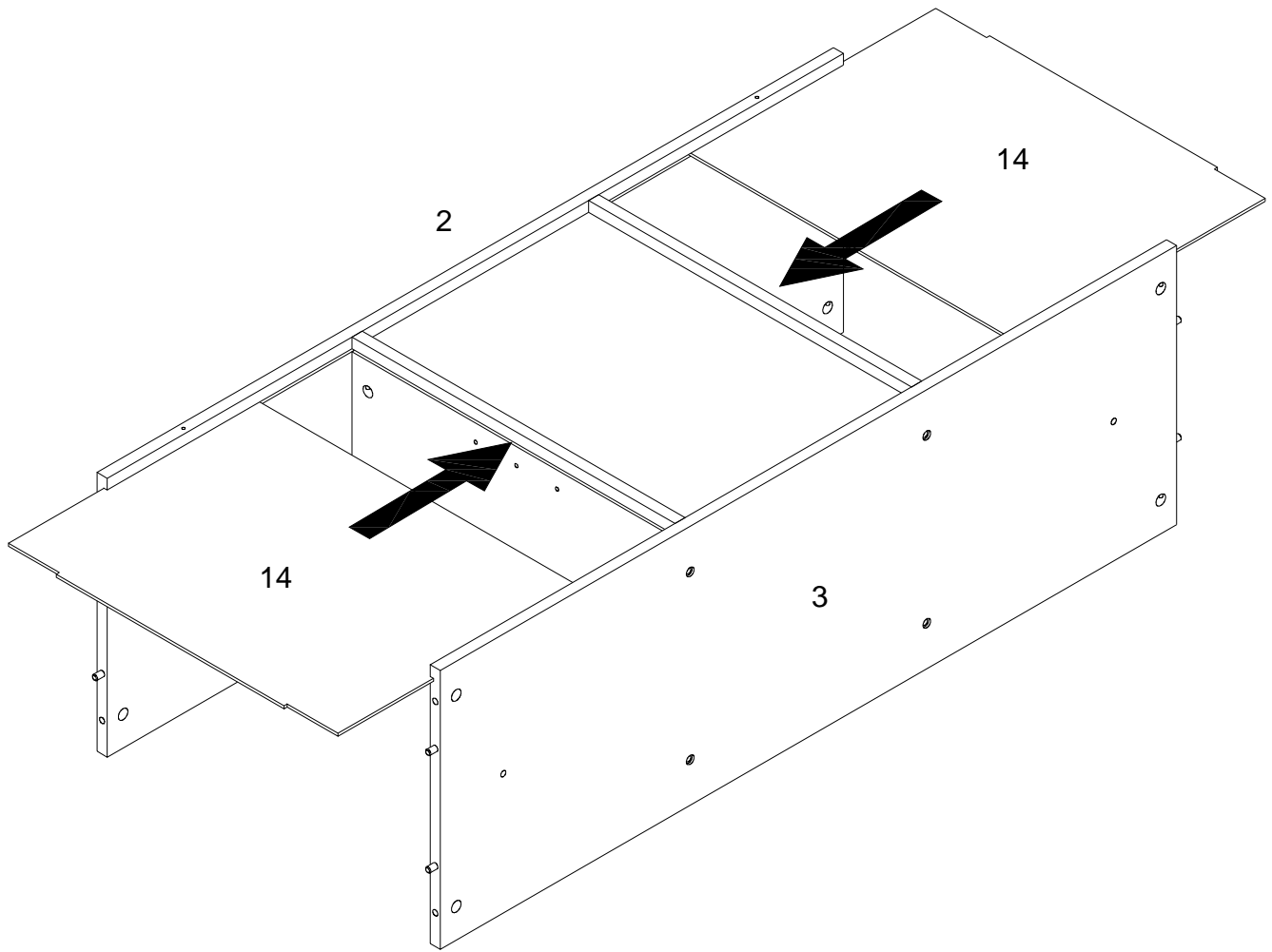

Insert part (14) into parts (2,3) as per diagram.

Step 8

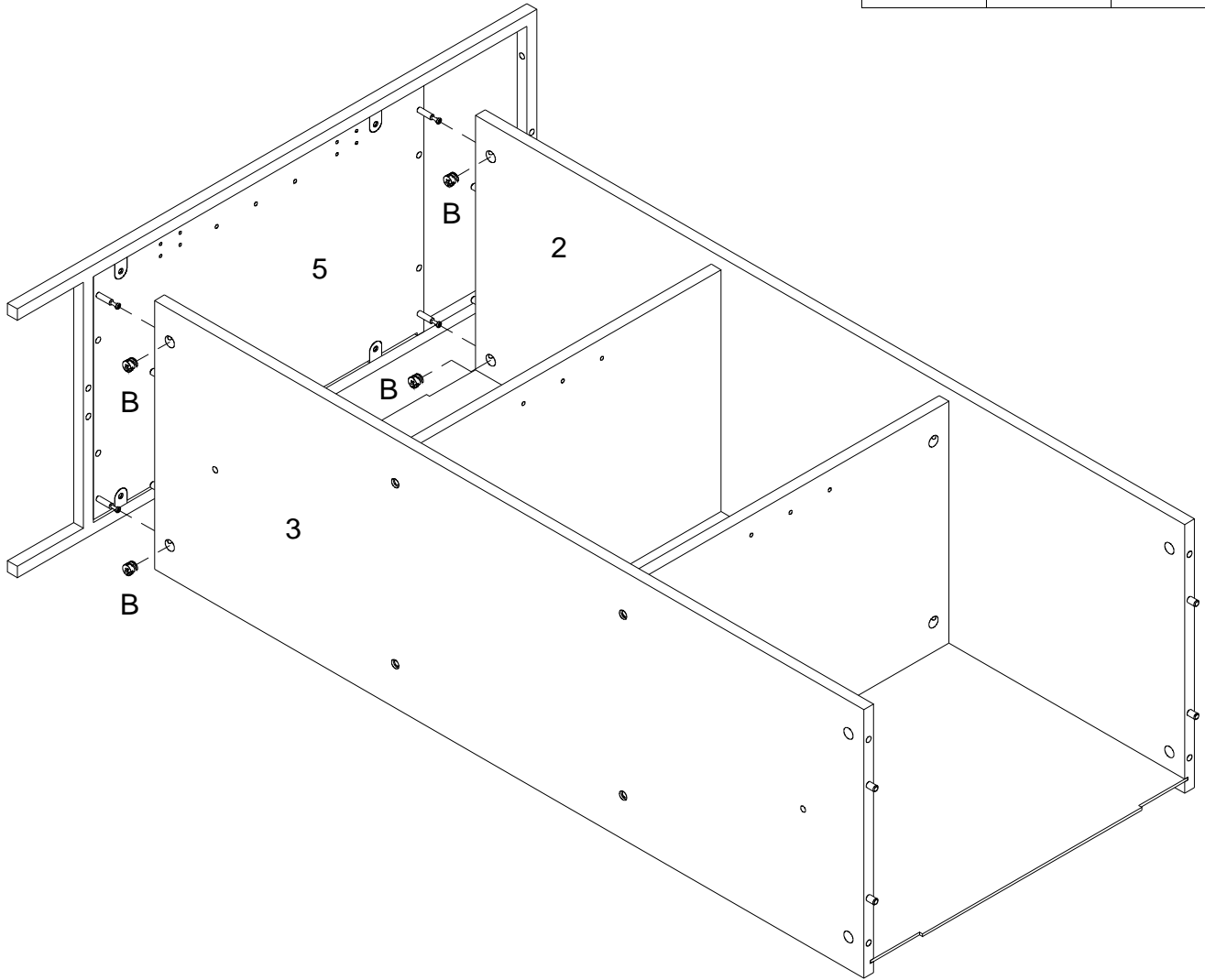
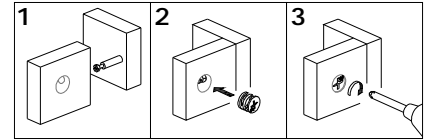

Using cam lock (B) secure parts (2,3) into part (5) with Philips head screwdriver as per diagram.

Step 9

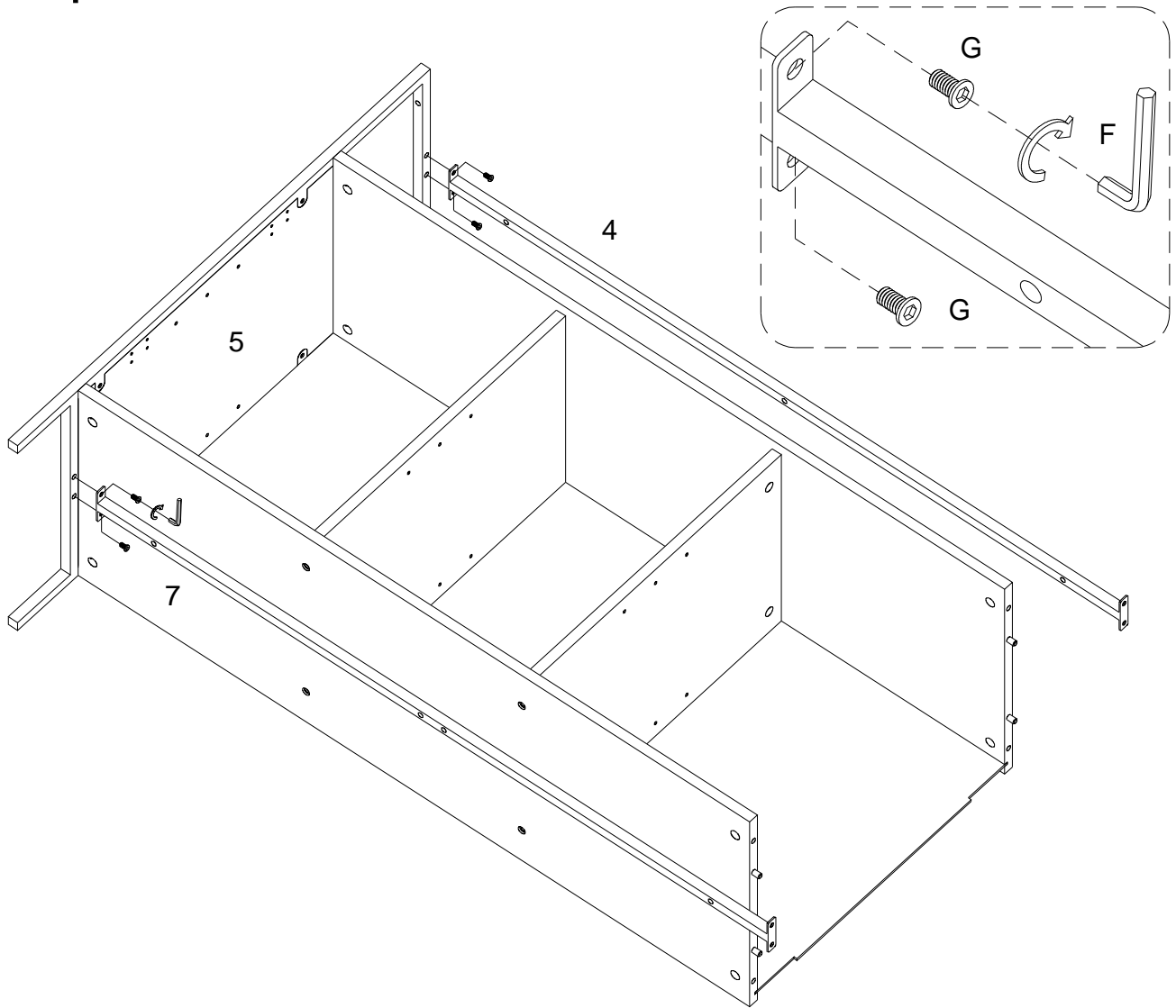

Using bolt (G) secure part (4,7) into part (5) with hex key (F) as per diagram.

Step 10

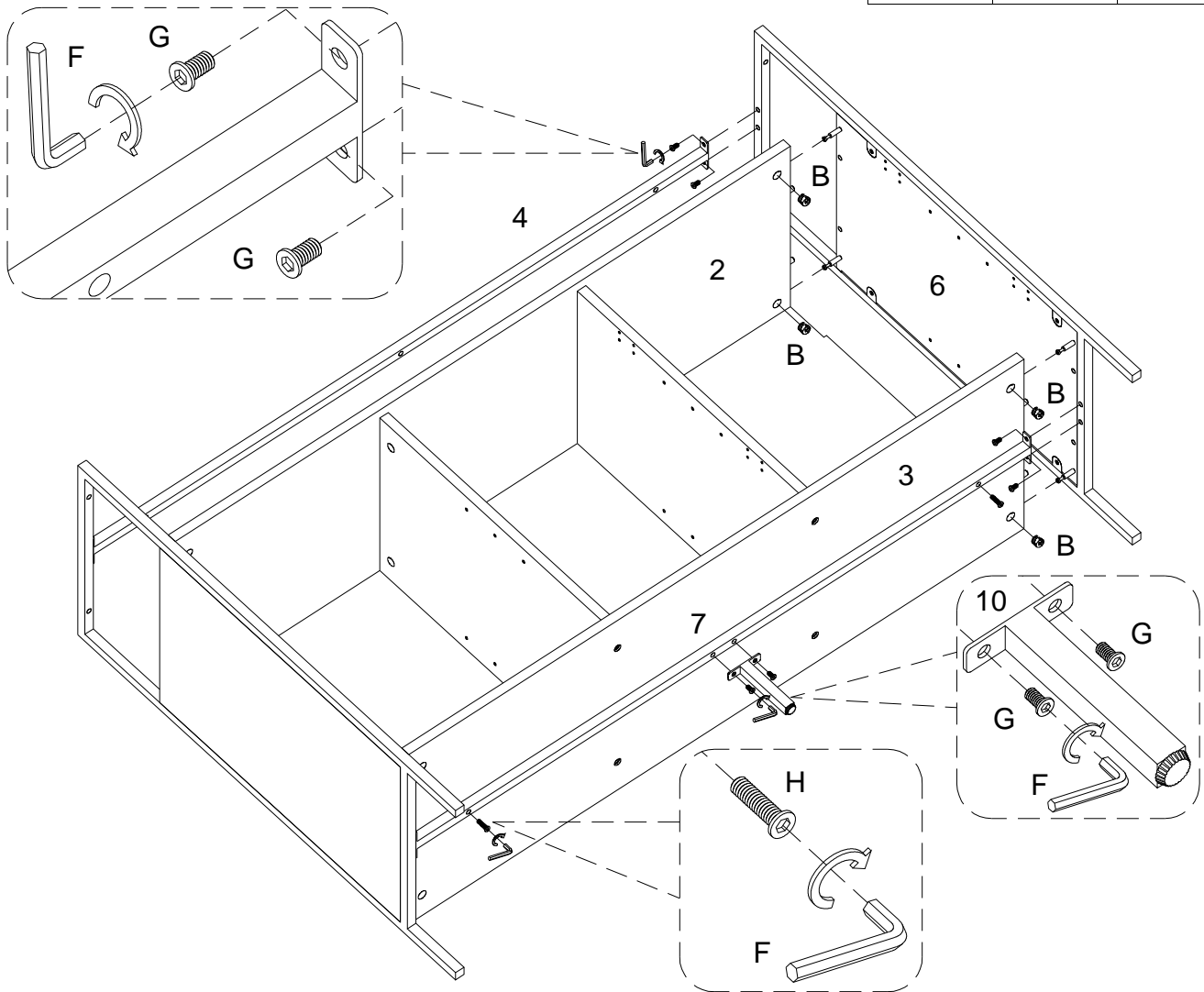
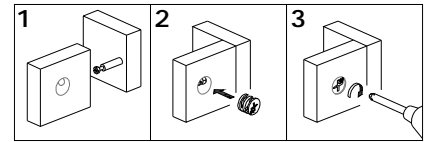

Using bolt (G) and cam lock (C) secure part (4,7) into parts (2,3,6) ,and using bolt (H) secure part (7) to part (3) with hex key (F) as per diagram.

Step 11

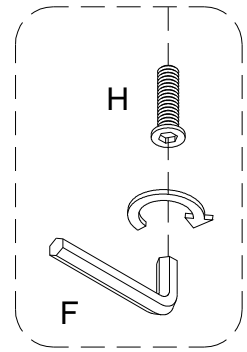
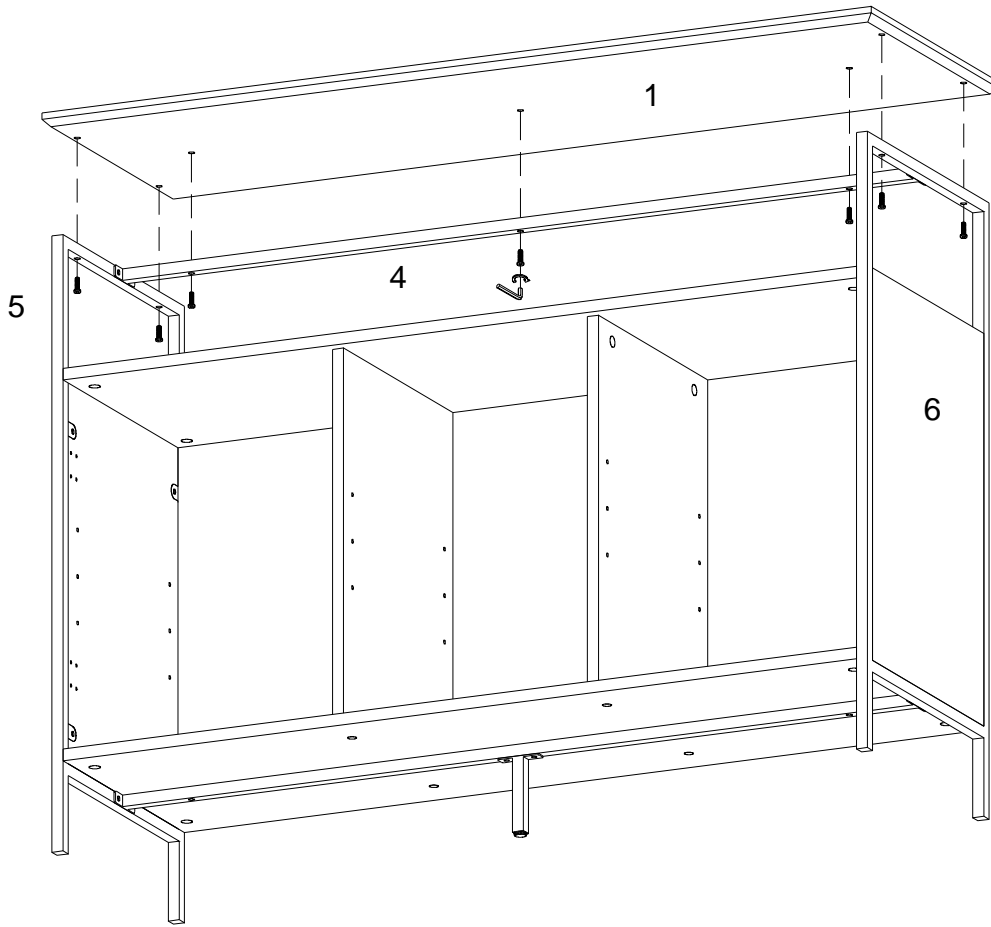

Using bolt (H) secure part (1) to parts (4,5,6) with hex key (F) as per diagram.

Step 12

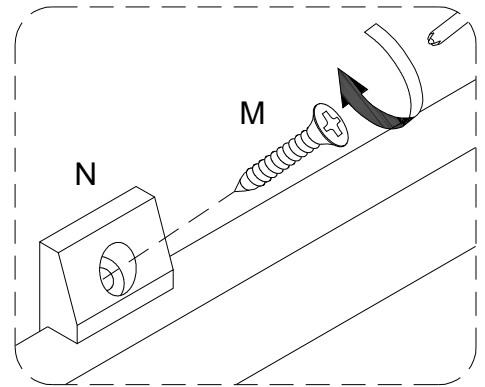
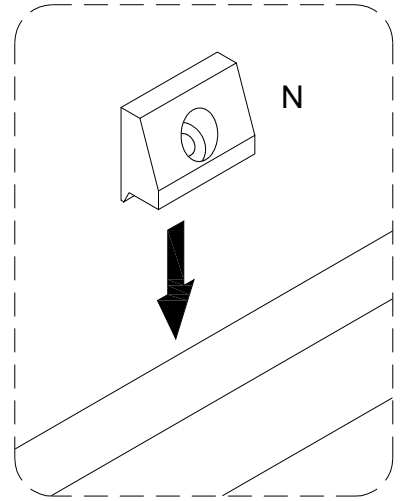
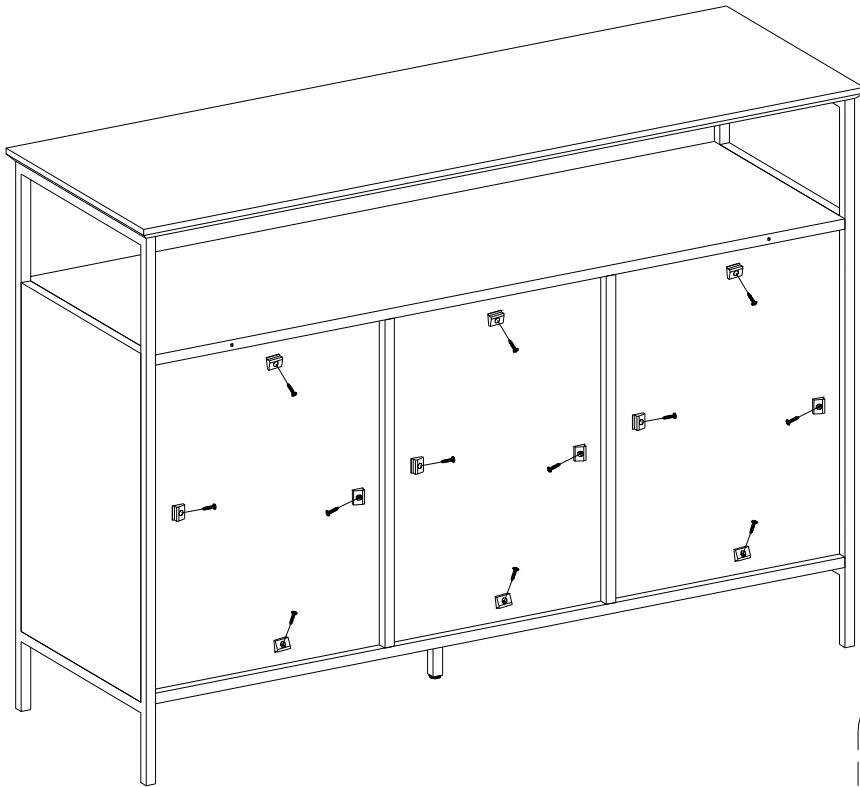

Using screw (M) secure plastic wedge (N) with Philips head screwdriver as per diagram.

Step 13

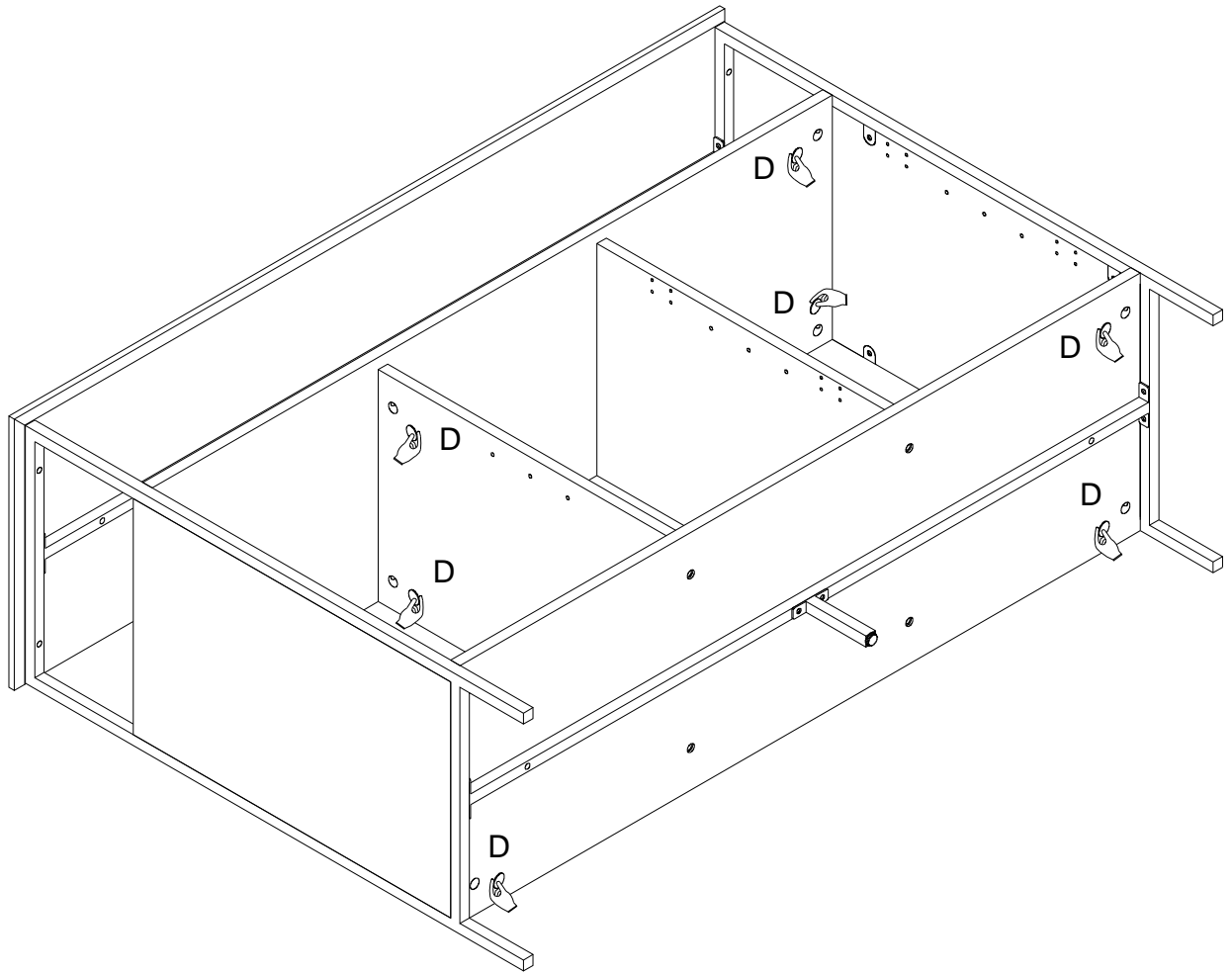

Put sticker (D) cover the holes as per diagram.

Step 14

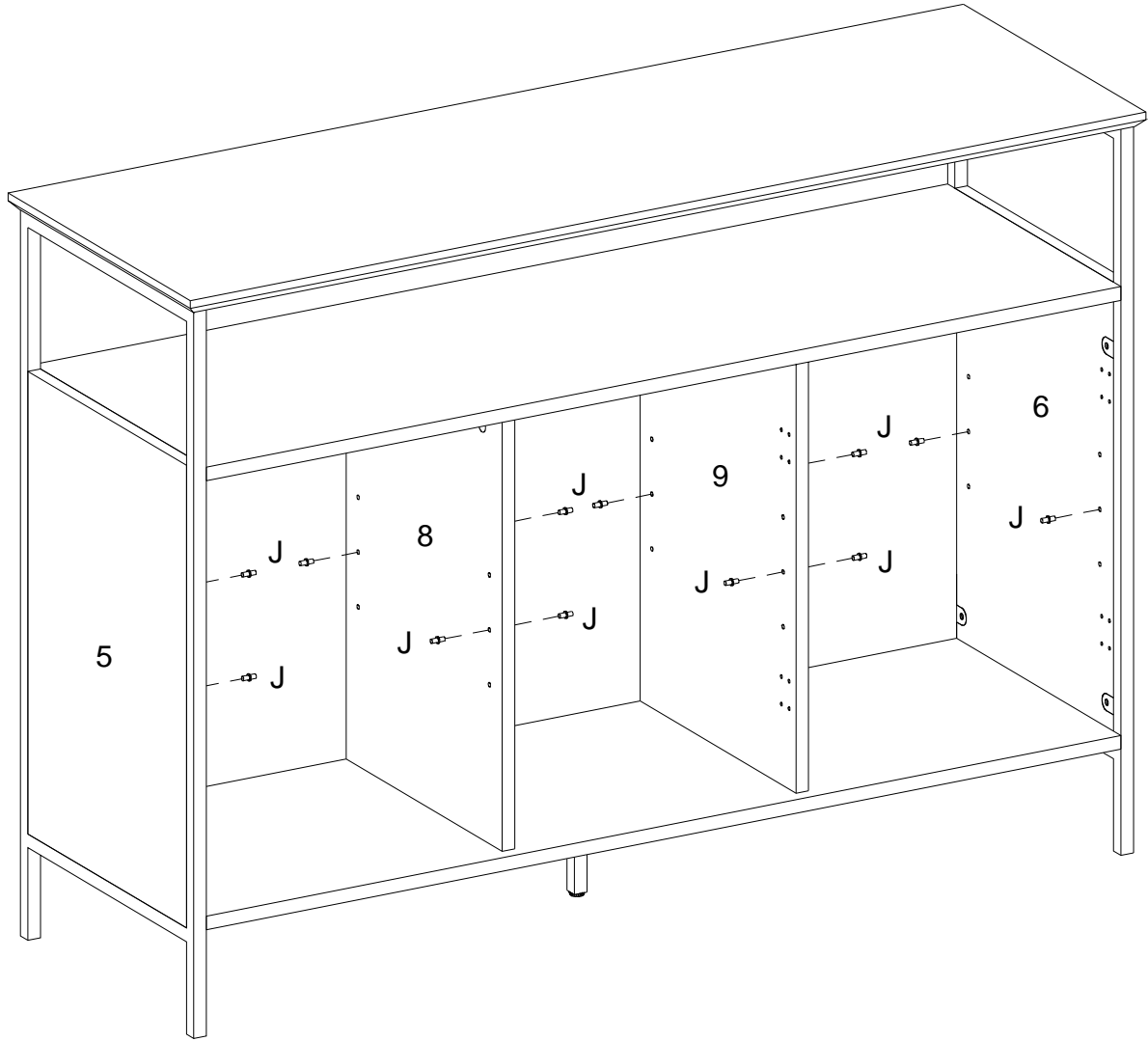

Insert shelf support pin into parts (5,6,8,9) as per diagram.

Step 15

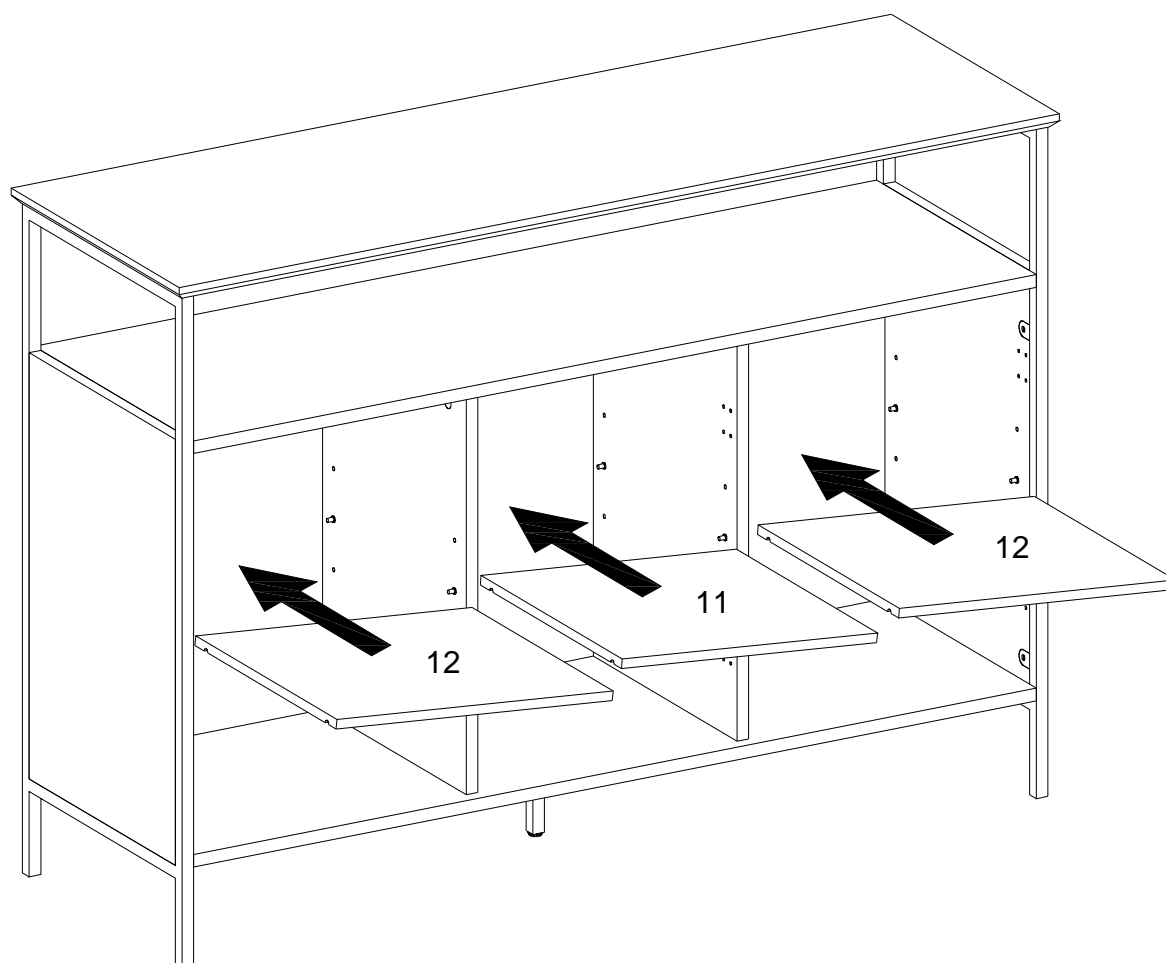

Put parts (11,12) as per diagram.

Step 16

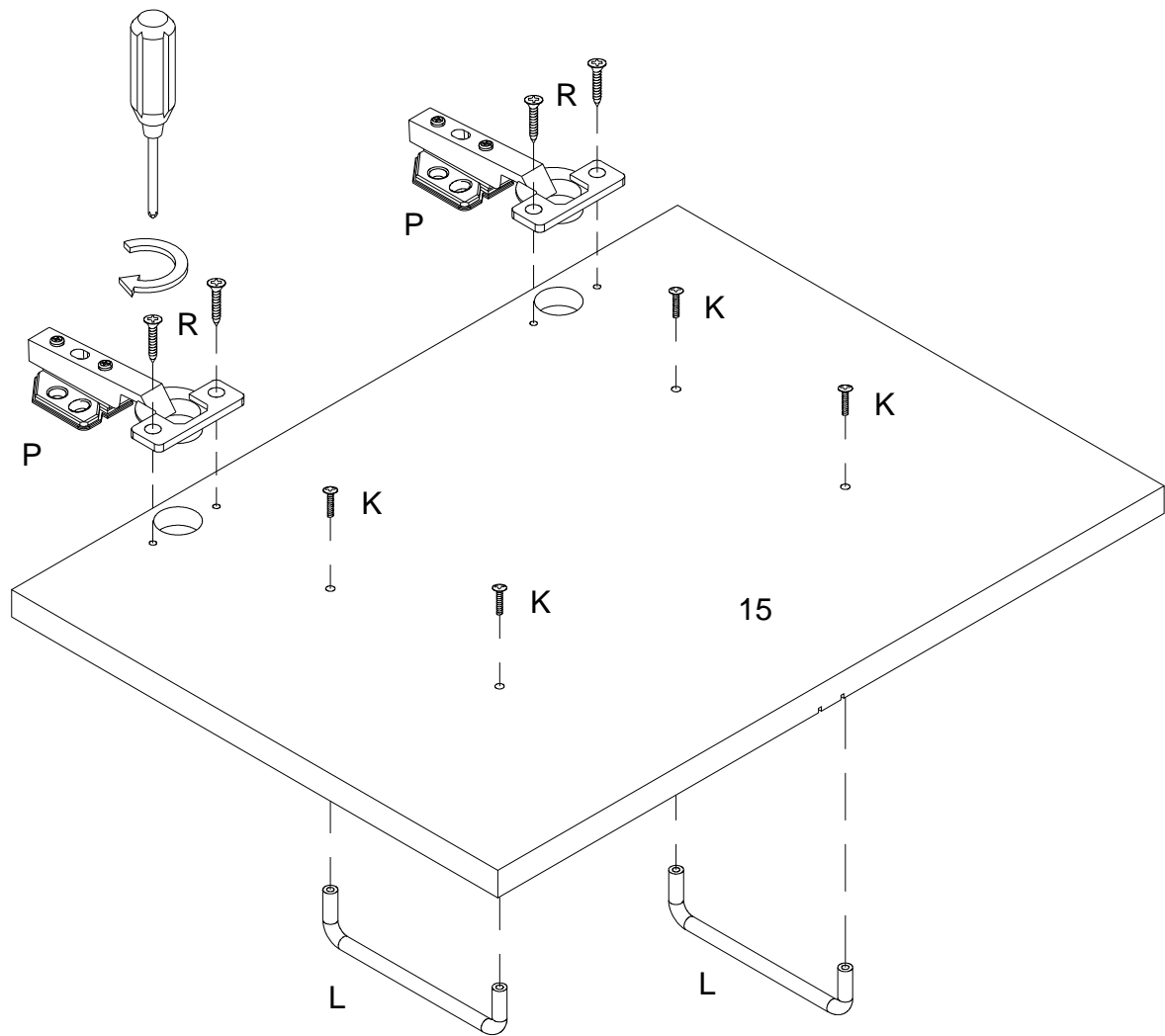

Using screw (R) secure west hinge (P) to part (15) , using bolt (K) secure part (15) to handle (L) with Philips head screwdriver as per diagram.

Step 17

x 2

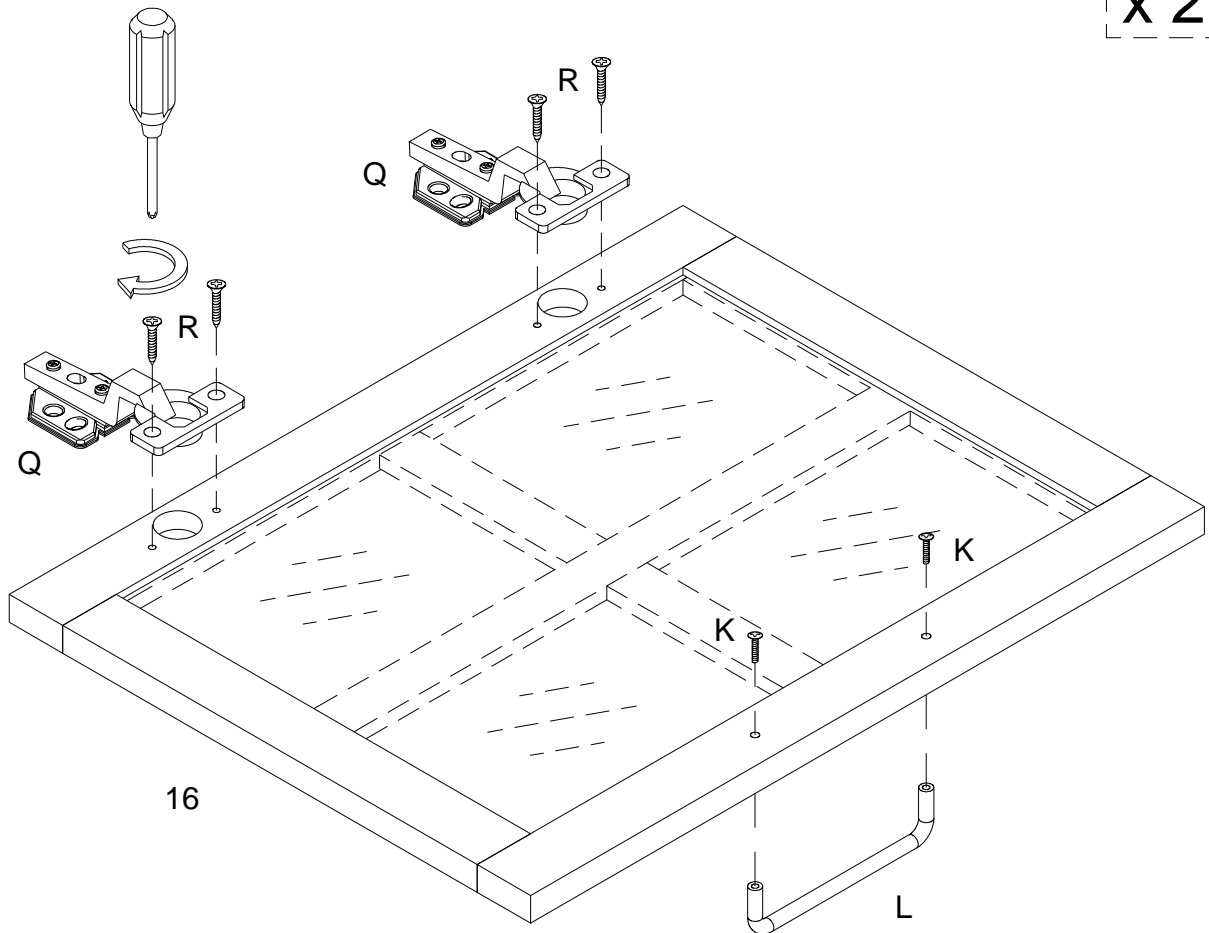

Using screw (R) secure west hinge (Q) to part (16) ,using bolt (K) secure part (16) to handle (L) with Philips head screwdriver as per diagram.

Step 18

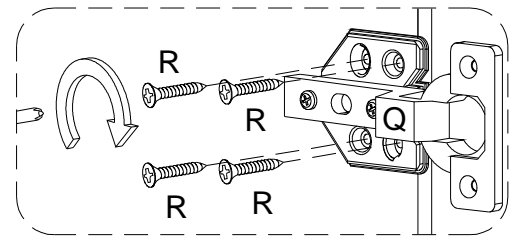
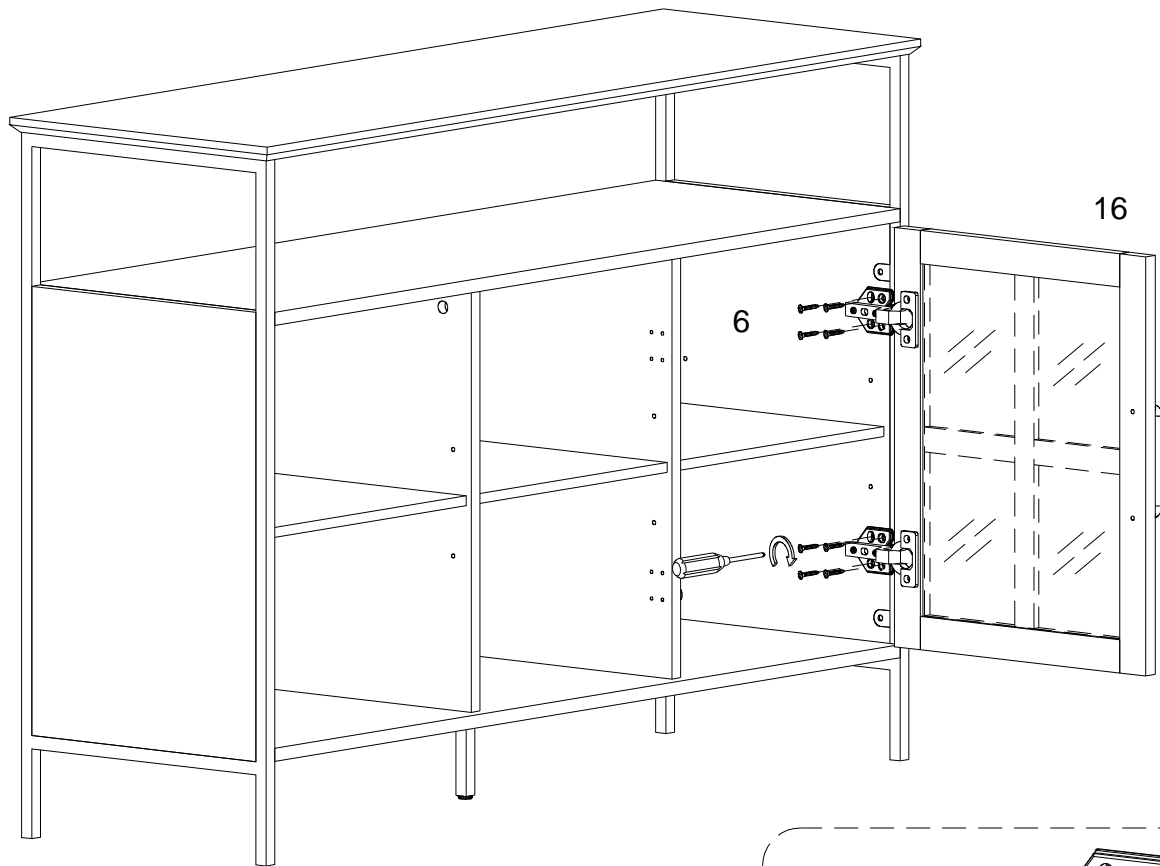

Using screw (R) secure west hinge (Q) to parts (6,16) with Philips head screwdriver as per diagram.

Step 19

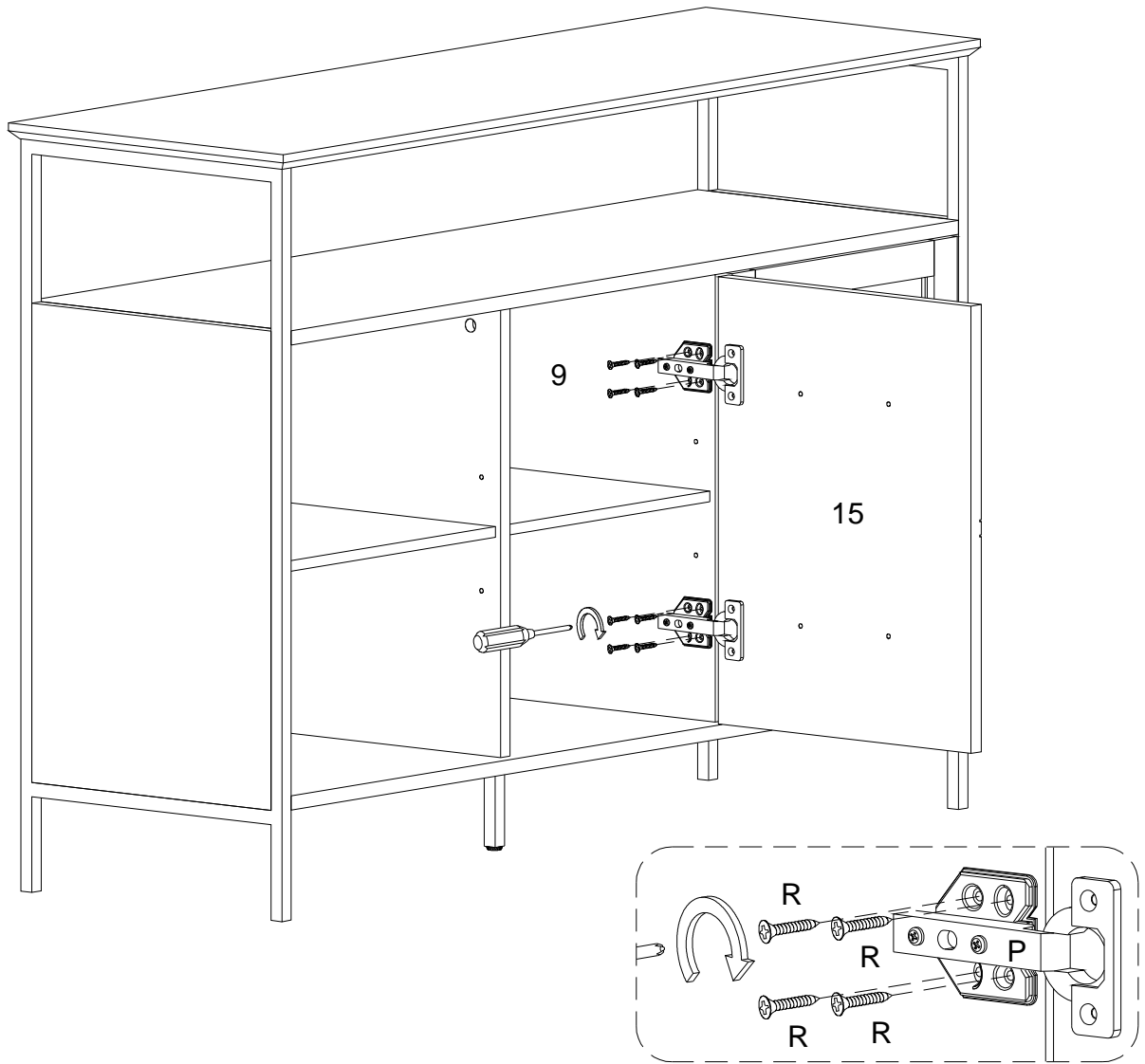

Using screw (R) secure west hinge (P) to parts (9,15) with Philips head screwdriver as per diagram.

Step 20

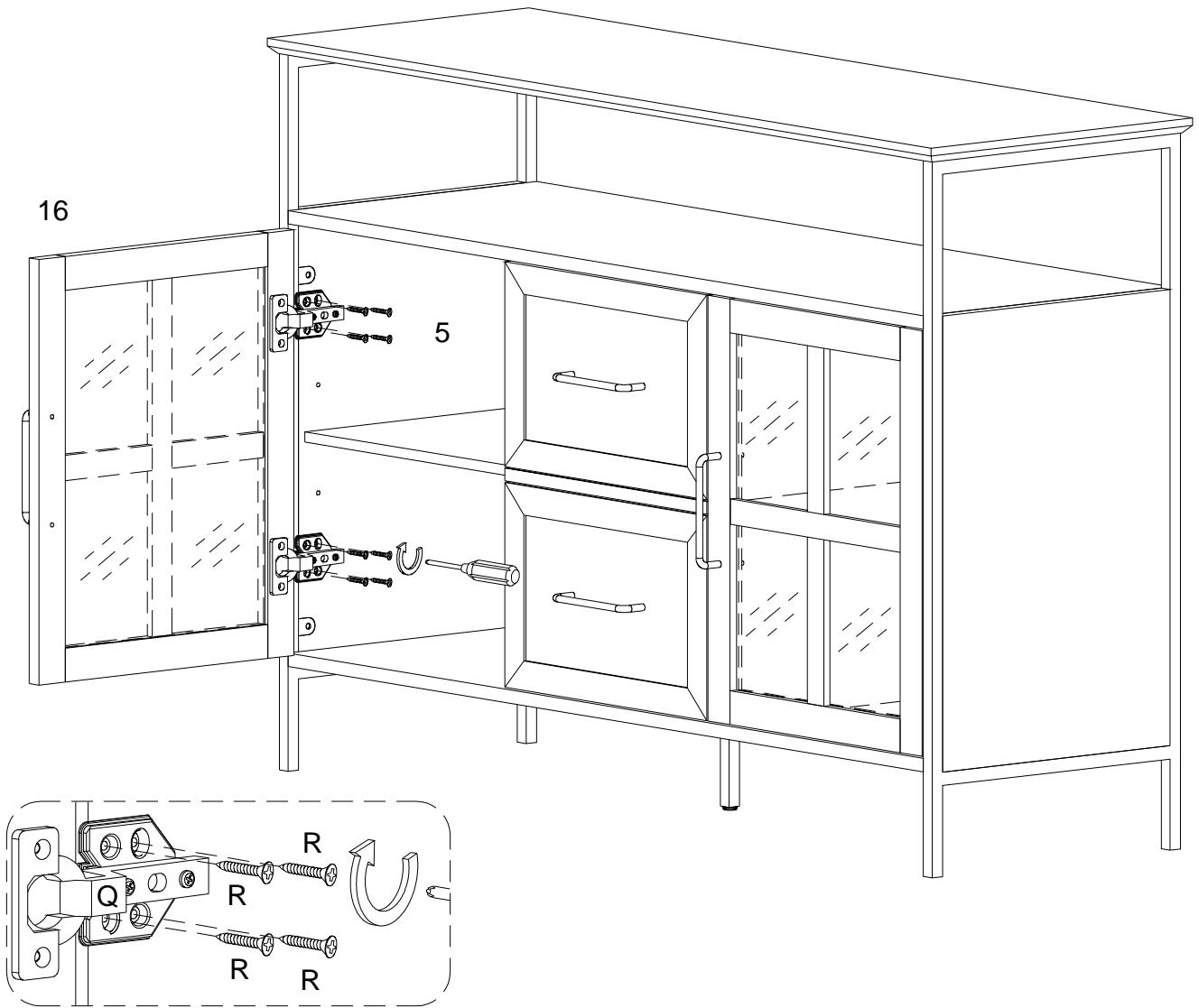

Using screw (R) secure west hinge (Q) to parts (5,16) with Philips head screwdriver as per diagram.

Step 21

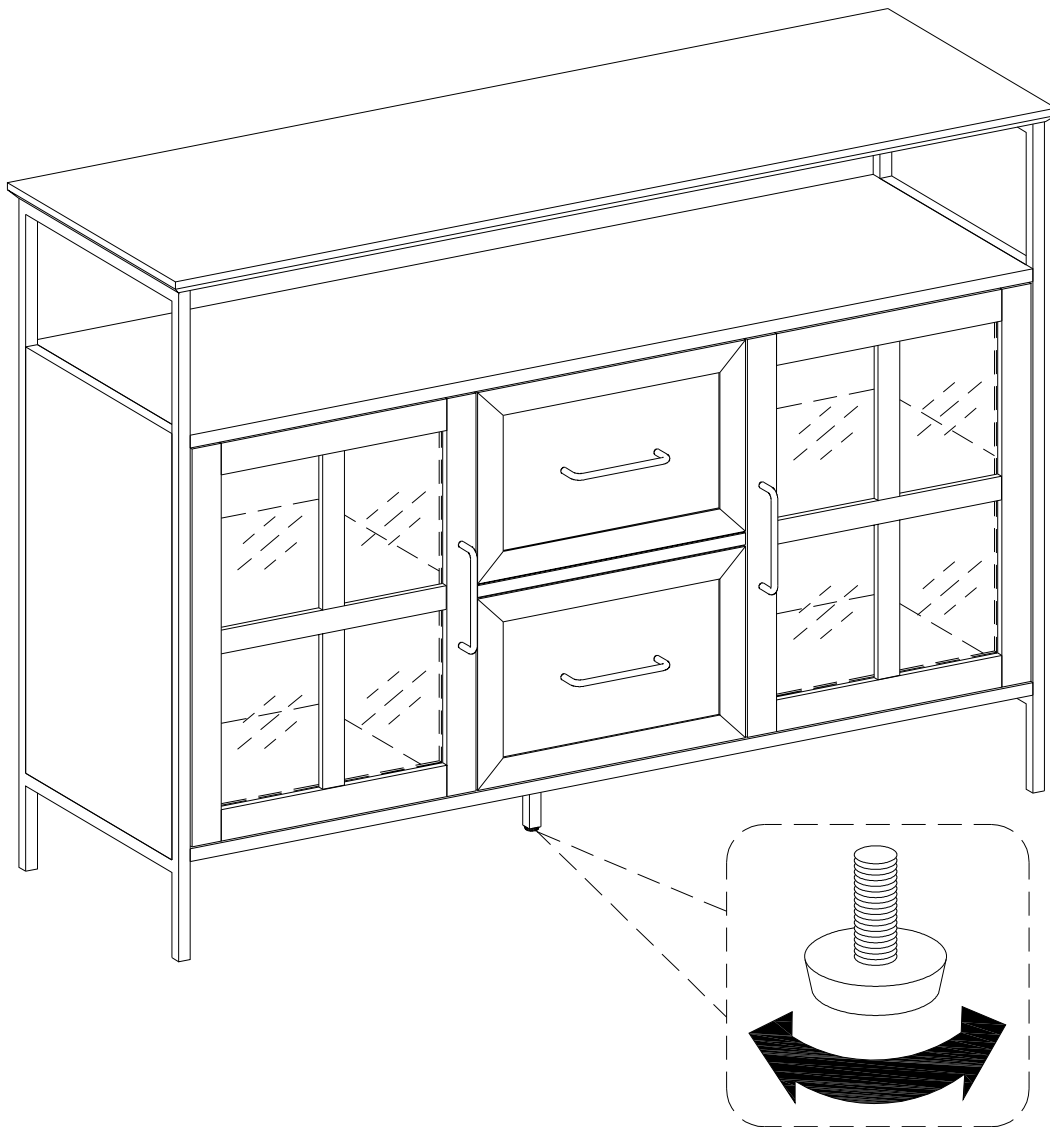

By adjusting the feet, ensure that the table is on the same level.

Step 22

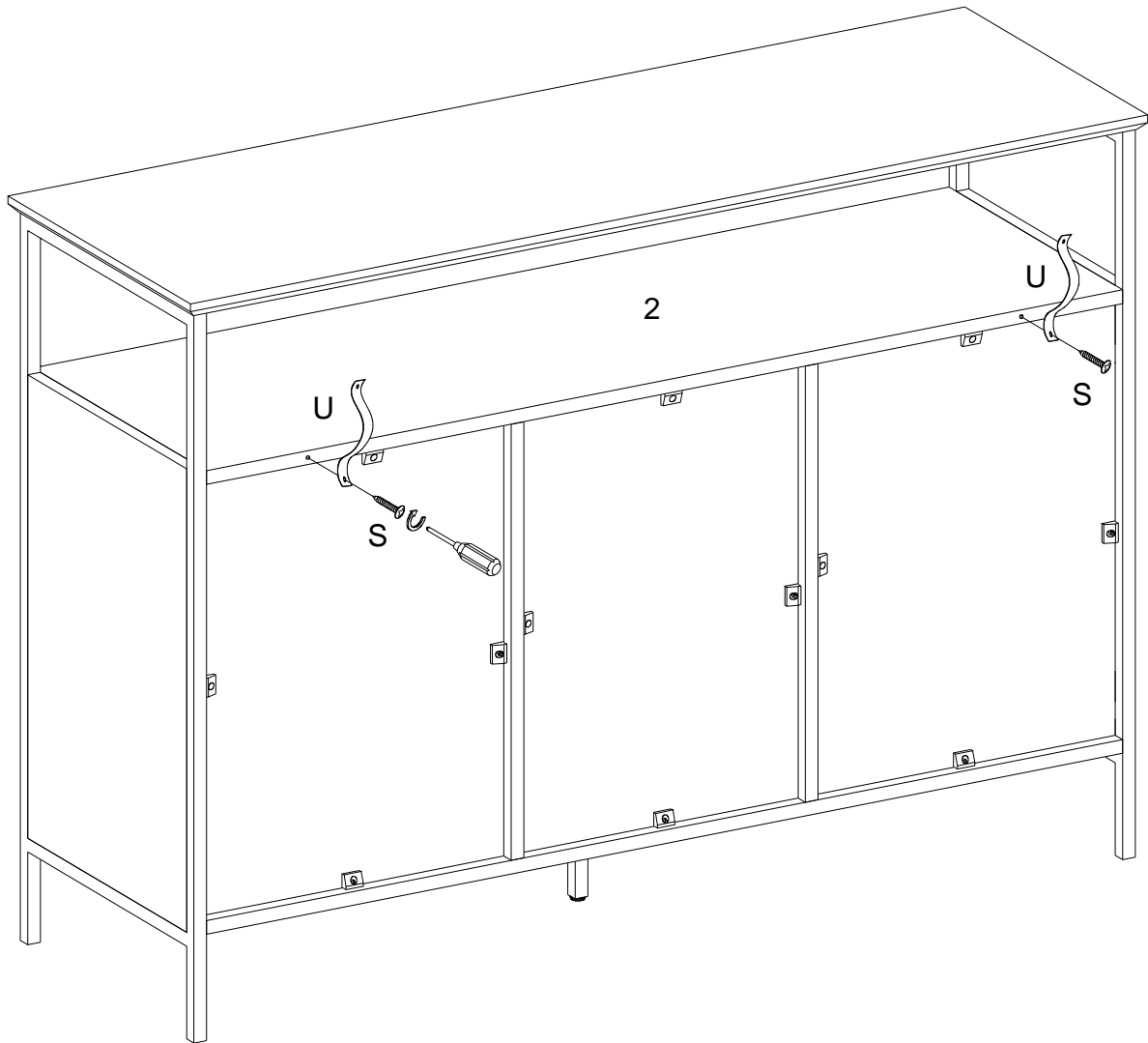

Using screw (S) secure plastic strap (U) into part (2) with Philips head screwdriver as per diagram.

Step 23

WARNING

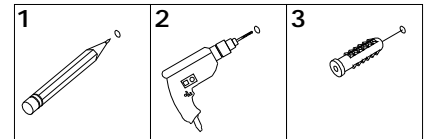

Serious or fatal injuries can occur from furniture tipping over. To prevent the furniture from tipping over we recommend that it is permanently fixed to the wall. Wall anchor and hardware are included with this product. Please make sure hardware is suitable for your walls before installing, as different wall materials may require different types of anchors.

Wall

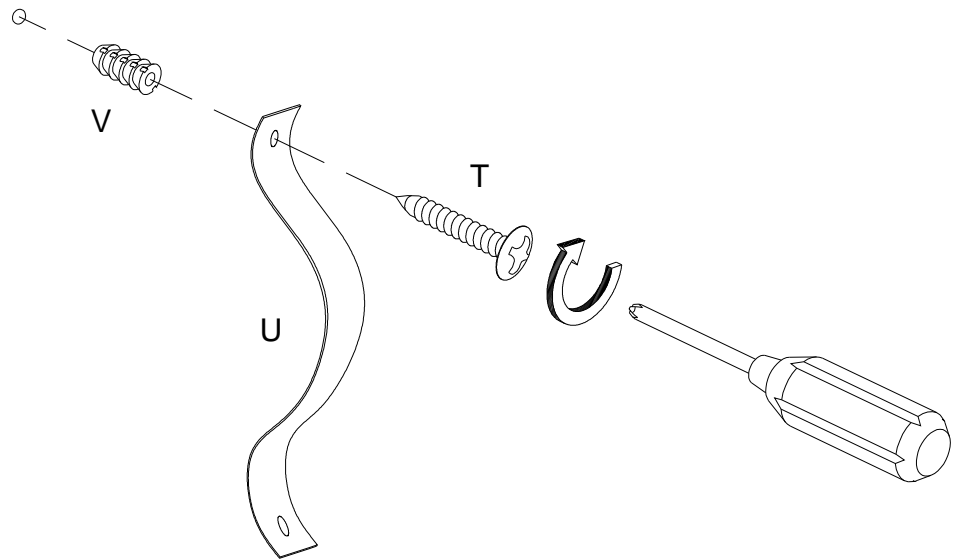

Using screw (T) secure plastic strap (U) and nut (V) into wall with Philips head screwdriver as per diagram.

Step 24

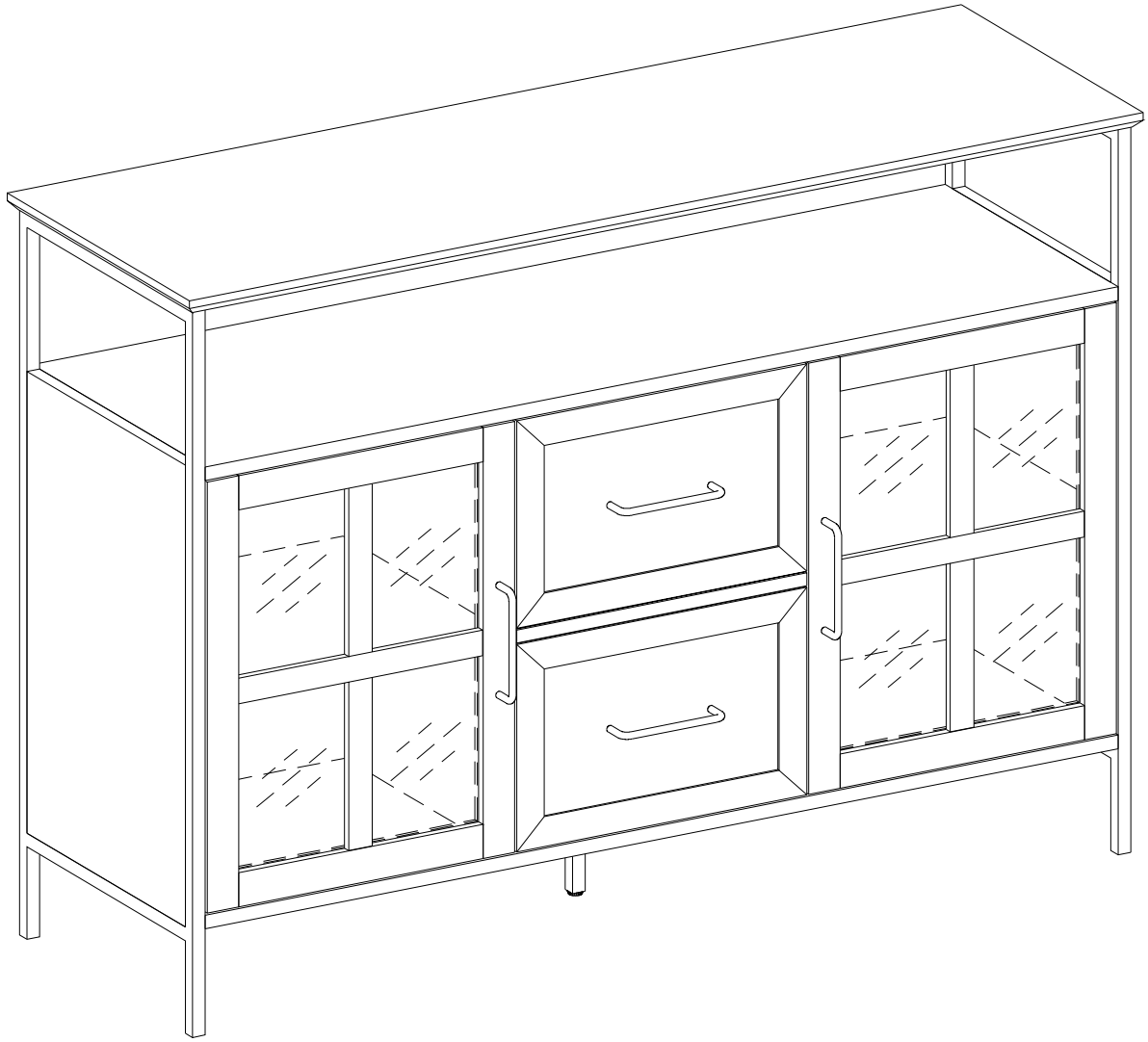

Final Assembly