

Upholstered platform bed

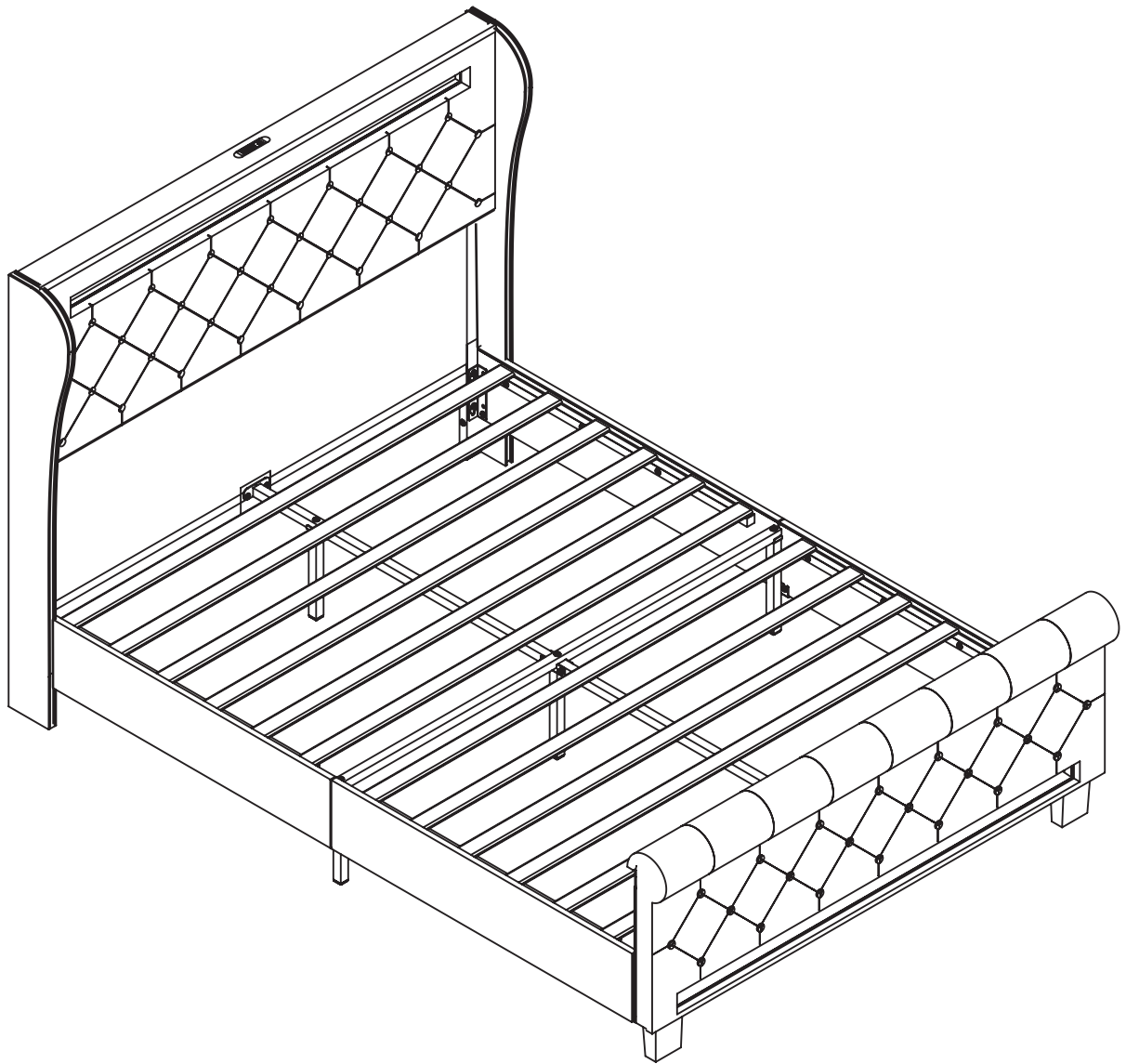

Dear Customers :

Thank you for purchasing our product. Please read this instruction manual carefully after receiving this product. It will help you assemble this product quickly, safely and correctly. You can keep this manual for future reference.

! IMPORTANT

Please follow the instruction manuals and use a pad to protect the product during your assembly.

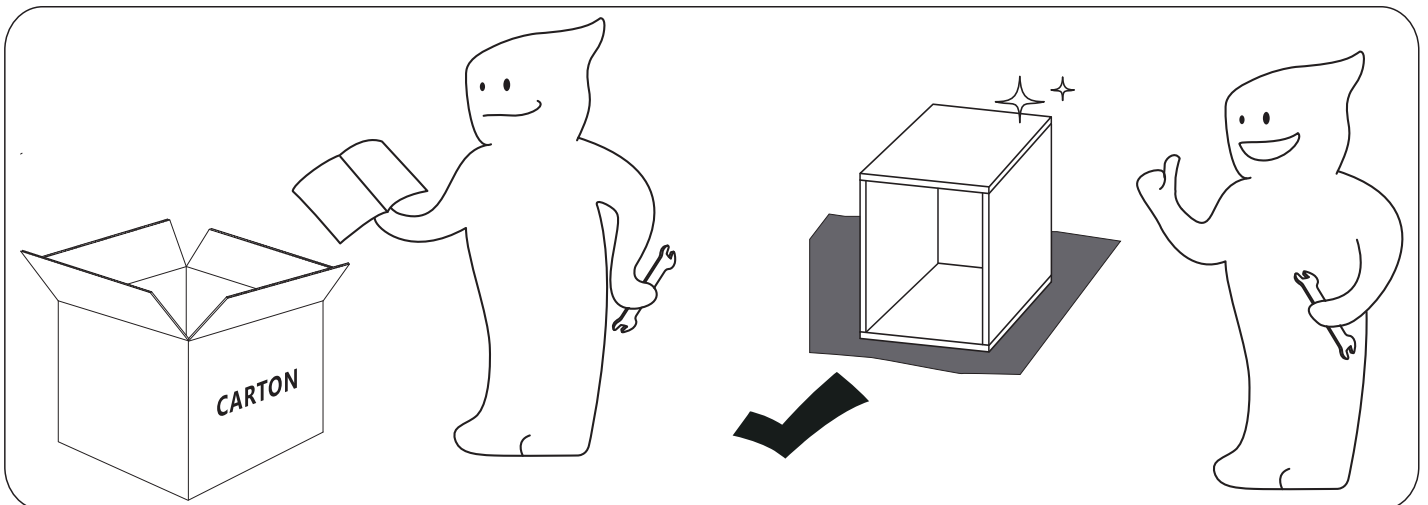
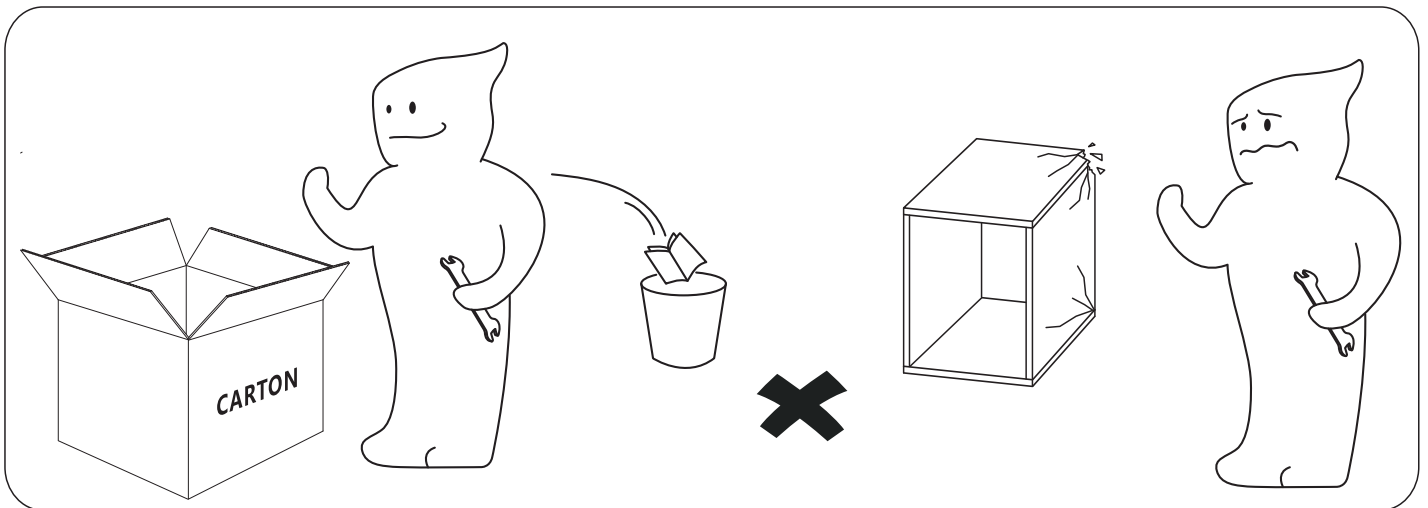

Note:

1. Should be assembled on flat ground to keep balance.
2. Before completing the installation, do not tighten the screws.

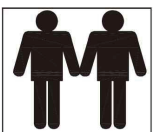

For easier and better assembly, **2** or more adults are required.

NOTICE:

-Please retain these instructions for future reference.

-Please read the instruction sheets completely before assembly. Remove all parts from the carton and ensure all components are included before assembly.

-Assemble the bed on a protected surface to avoid scratching the components of the bed. Be careful not to cross-thread screws. Please use a piece of the cardboard packaging to protect your floor and product.

-Two people are recommended for assembly!

-Don't tighten all screws before you have installed all the parts of the bed.

-When you assemble your bed, if you smell a weird smell of the material, please don't worry it's very Normal. What you should do is to air it for 1 or 2 days on your balcony, patio, or near your window. Our bed have been certified by the environment authority. So please don't worry it won't hurt your health, it's completely safe.

NOTICE:

RETURN/DAMAGE CLAIM INSTRUCTIONS:

-If the package is damaged, please contact us as soon as possible and attach the damaged photo.

-Return Policy: This item can be returned within 30 days without any reason. If you return this item for personal reasons, you need to bear the freight of returns and order processing fee (0-50% restocking fee based on the invoice price). If the product has quality issues (not caused by humans), we will bear the freight.

-If you need to return the goods, please keep the original box. Please make sure to use the return label provided by us and do not return it without permission. Please do not share a label with multiple boxes.

-If you return the product after 30 days from receiving it, we are afraid that your return application won't be accepted. We appreciate your understanding.



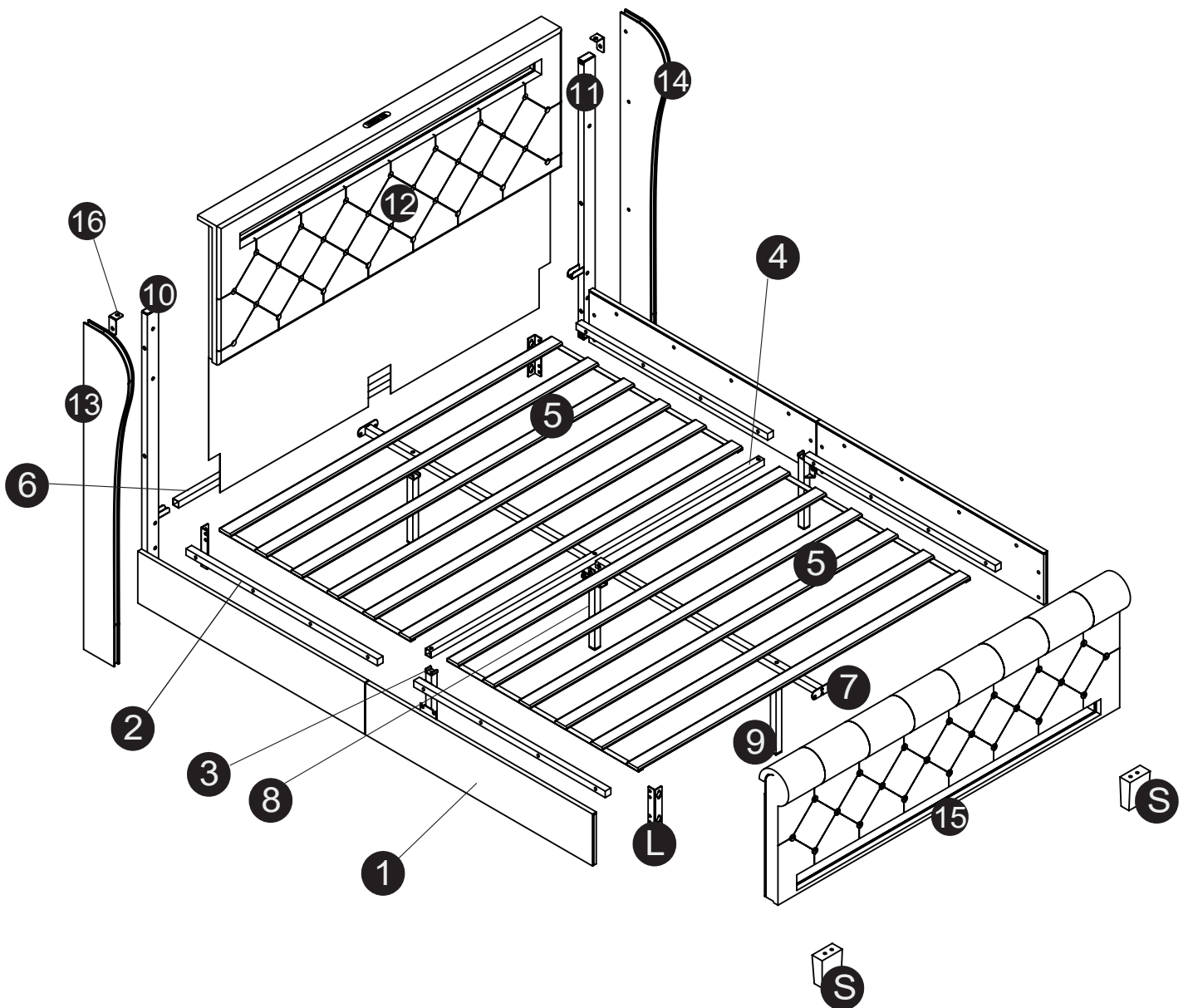

-The warranty product is one year. If this item is damaged within the warranty period we will arrange you the replacement parts free of charge. If the item is damaged for some personal reasons, we could also replace it for you, however you need to bear the transport fees.

ASSEMBLY INSTRUCTIONS



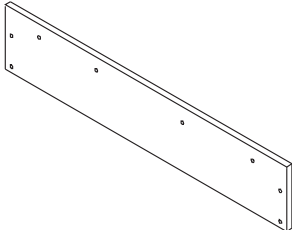

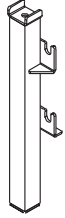
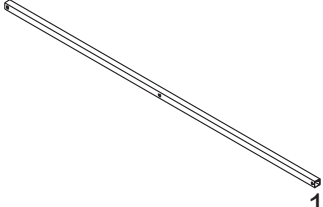
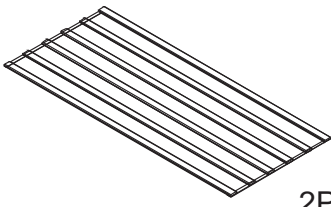
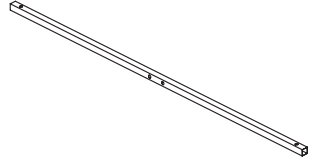
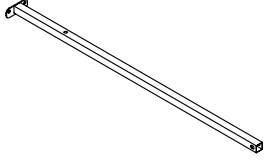
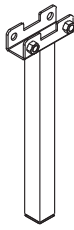

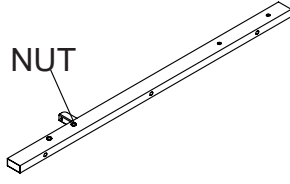
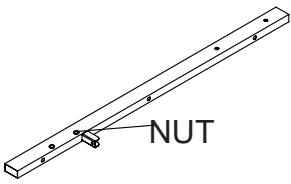
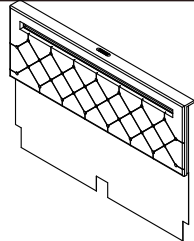
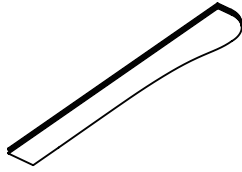
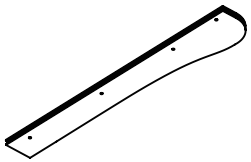
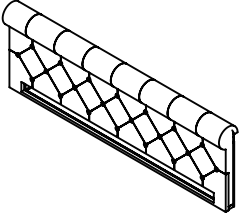
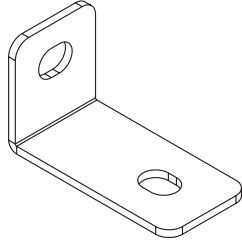
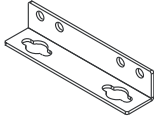
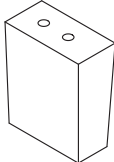
ASSEMBLY INSTRUCTIONS

PARTS LIST

1  4PCS	2  4PCS	3  2PCS
4  1PC	5  2PCS	6  1PC
7  2PCS	8  1PCS	9  2PCS
10  NUT 1PC	11  NUT 1PC	12  1PC
13  1PC	14  1PC	15  1PC
16  2PCS	L  4PCS	S  2PCS

ASSEMBLY INSTRUCTIONS

PARTS LIST

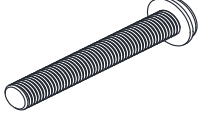
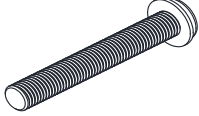
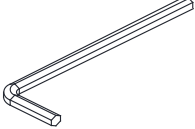
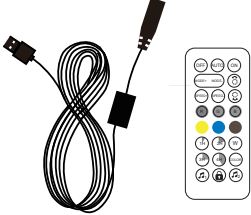
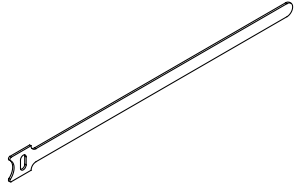
A  M8x18 24PCS	B  M8x28 6PCS	C  M8x38 26PCS
D  M8x45 4PCS	E  M8x70 7PCS	F  M6x70 4PCS
G  1PC	K  1PC	I  6PCS

ASSEMBLY INSTRUCTIONS

1

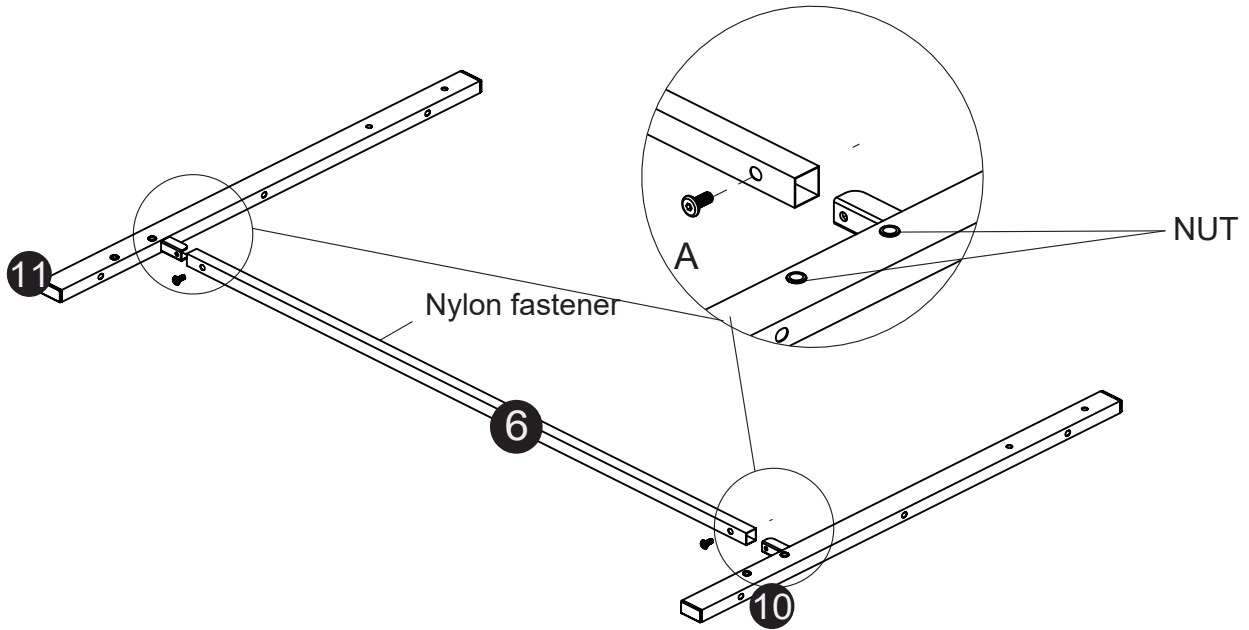

A	 M8x18	2PCS
---	---	------

2

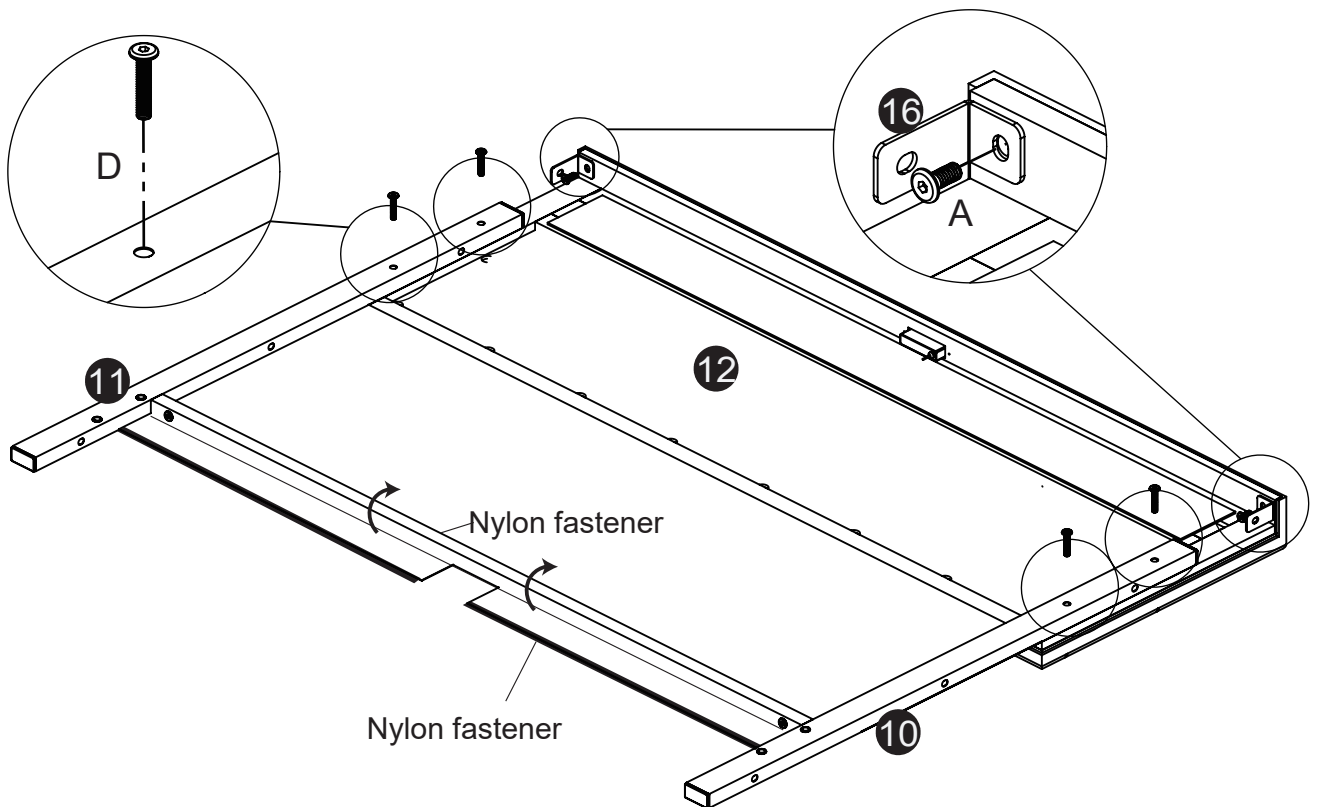

Move the fabric on the Nylon fastener for fixing

A	 M8x18	2PCS
D	 M8x45	4PCS

ASSEMBLY INSTRUCTIONS

3

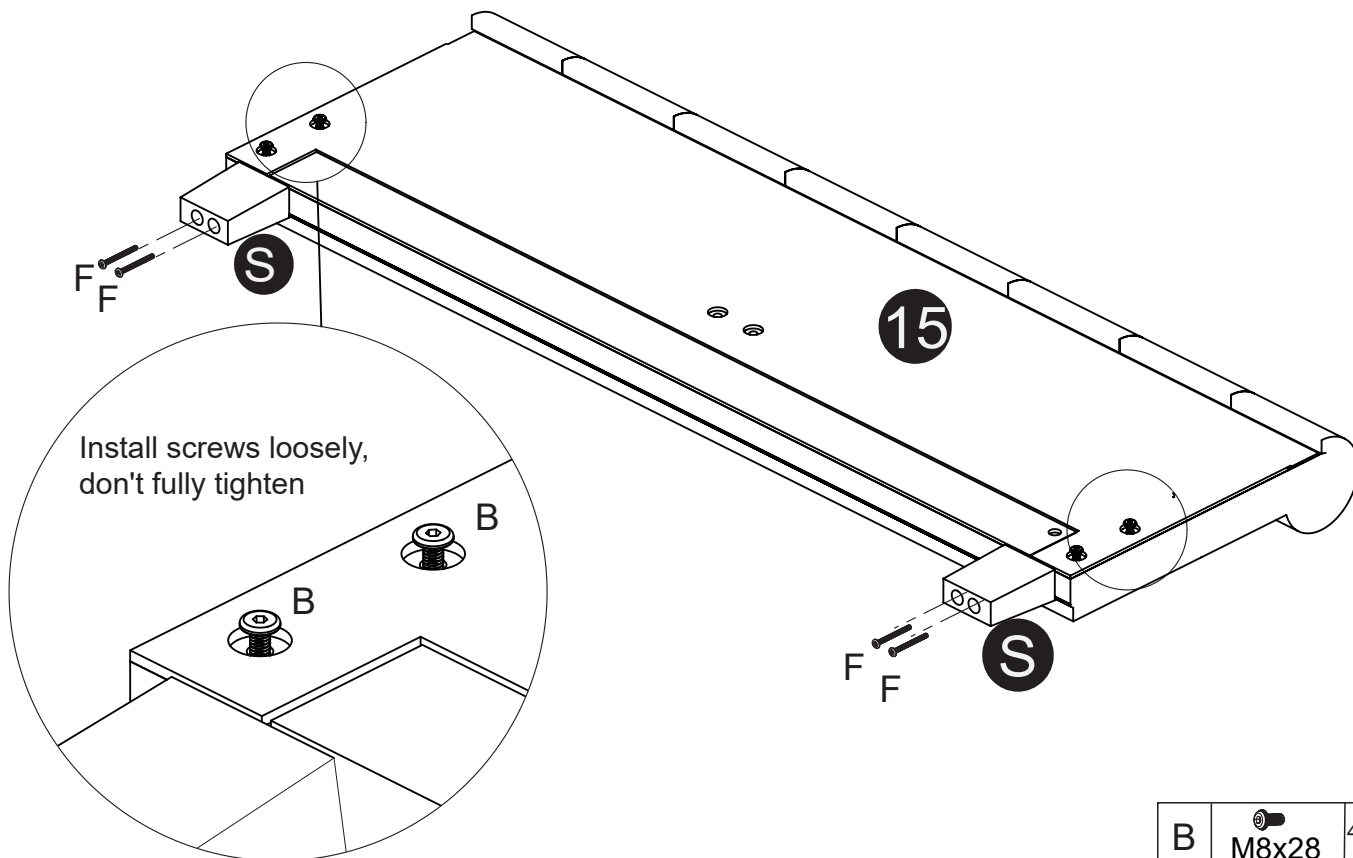

B	M8x28	4PCS
F	M6x70	4PCS

4

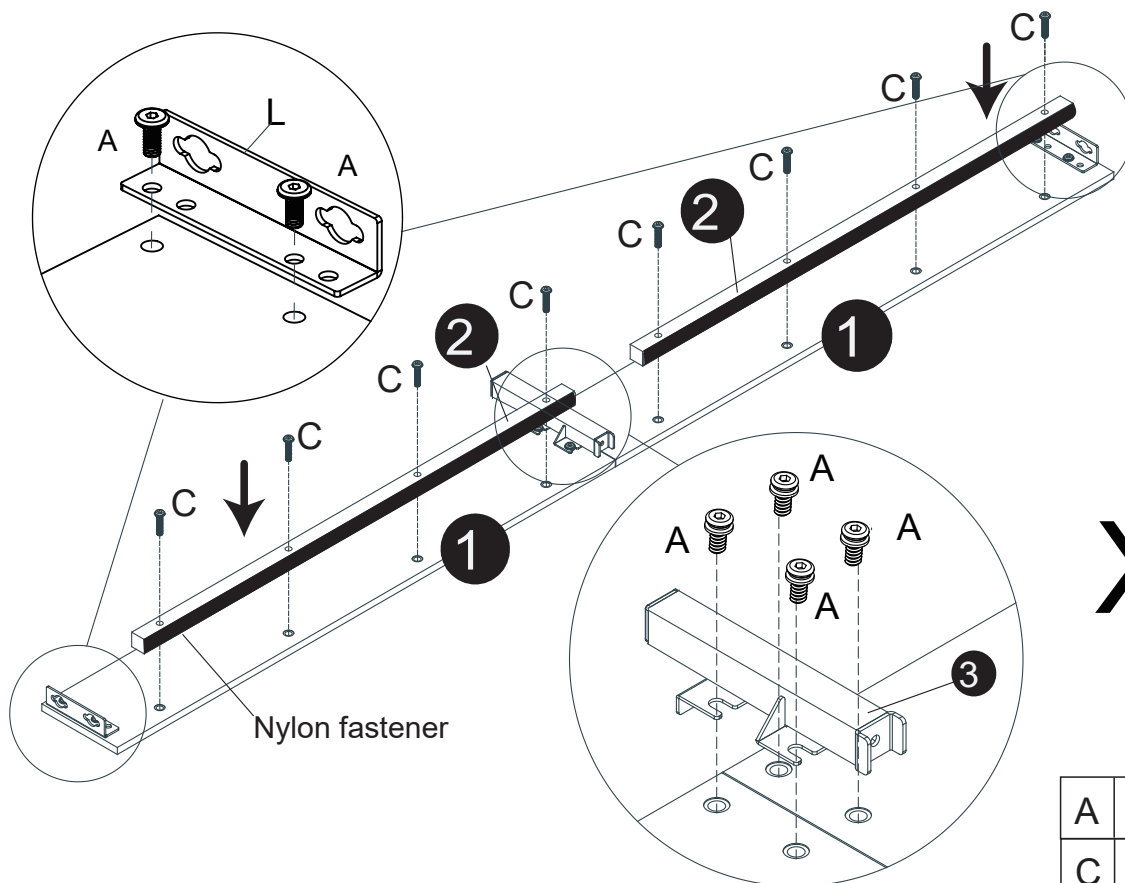

A	M8x18	16PCS
C	M8x38	16PCS

ASSEMBLY INSTRUCTIONS

5

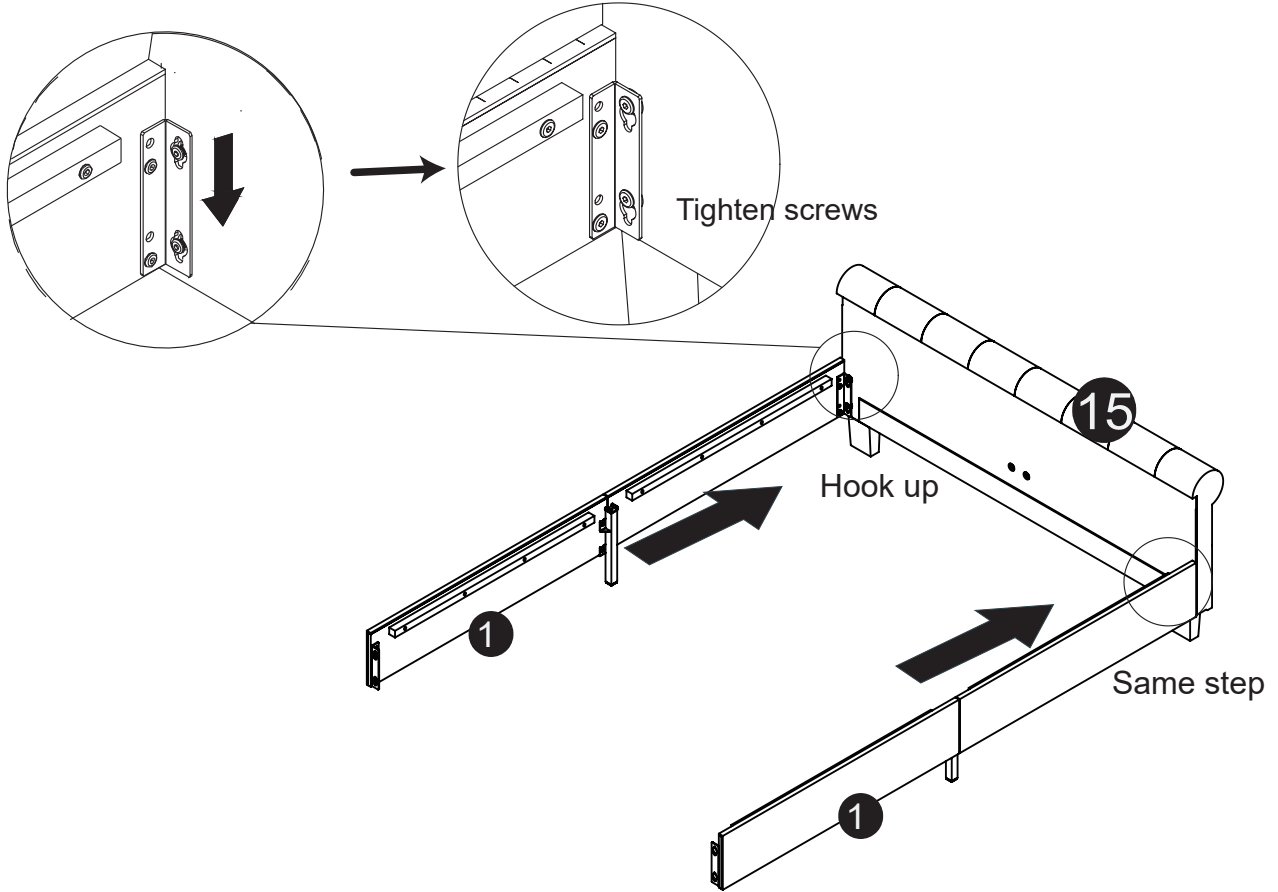

6

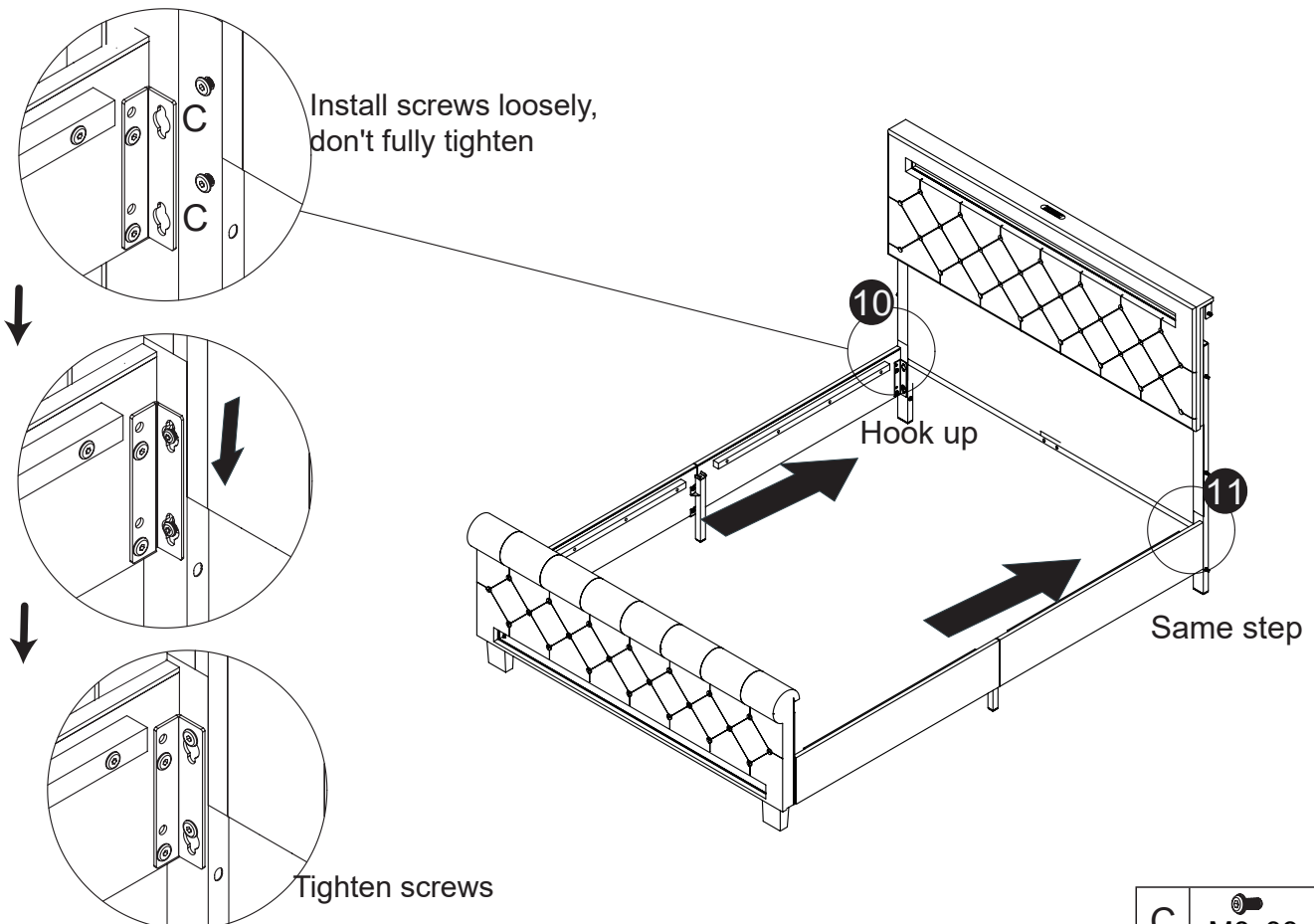

C	 M8x38	4PCS
---	---	------

ASSEMBLY INSTRUCTIONS

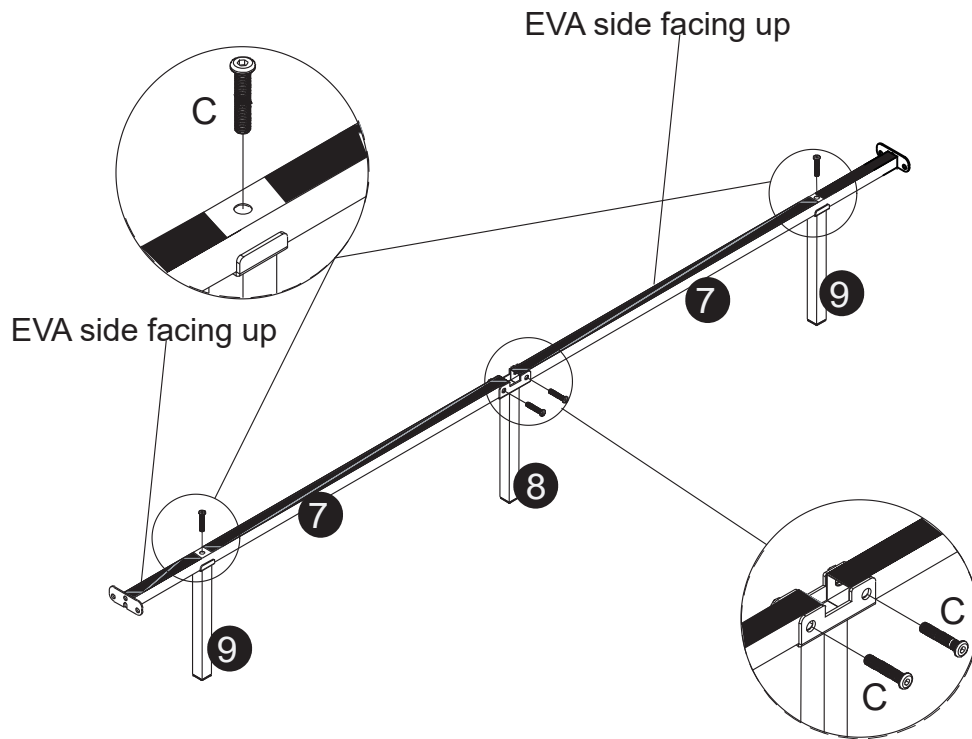

7

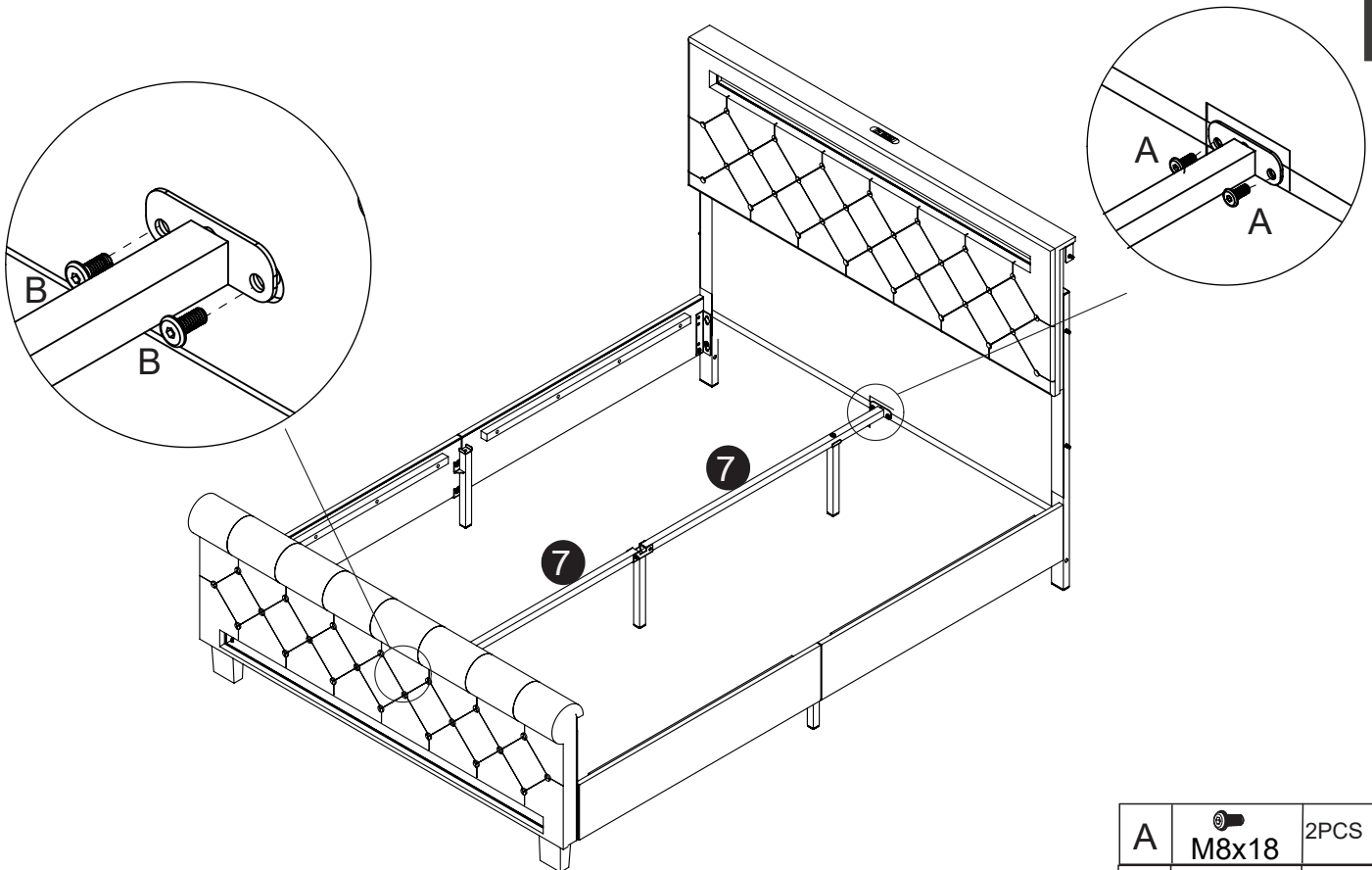

C	 M8x38	4PCS
---	--	------

8



A	 M8x18	2PCS
B	 M8x28	2PCS

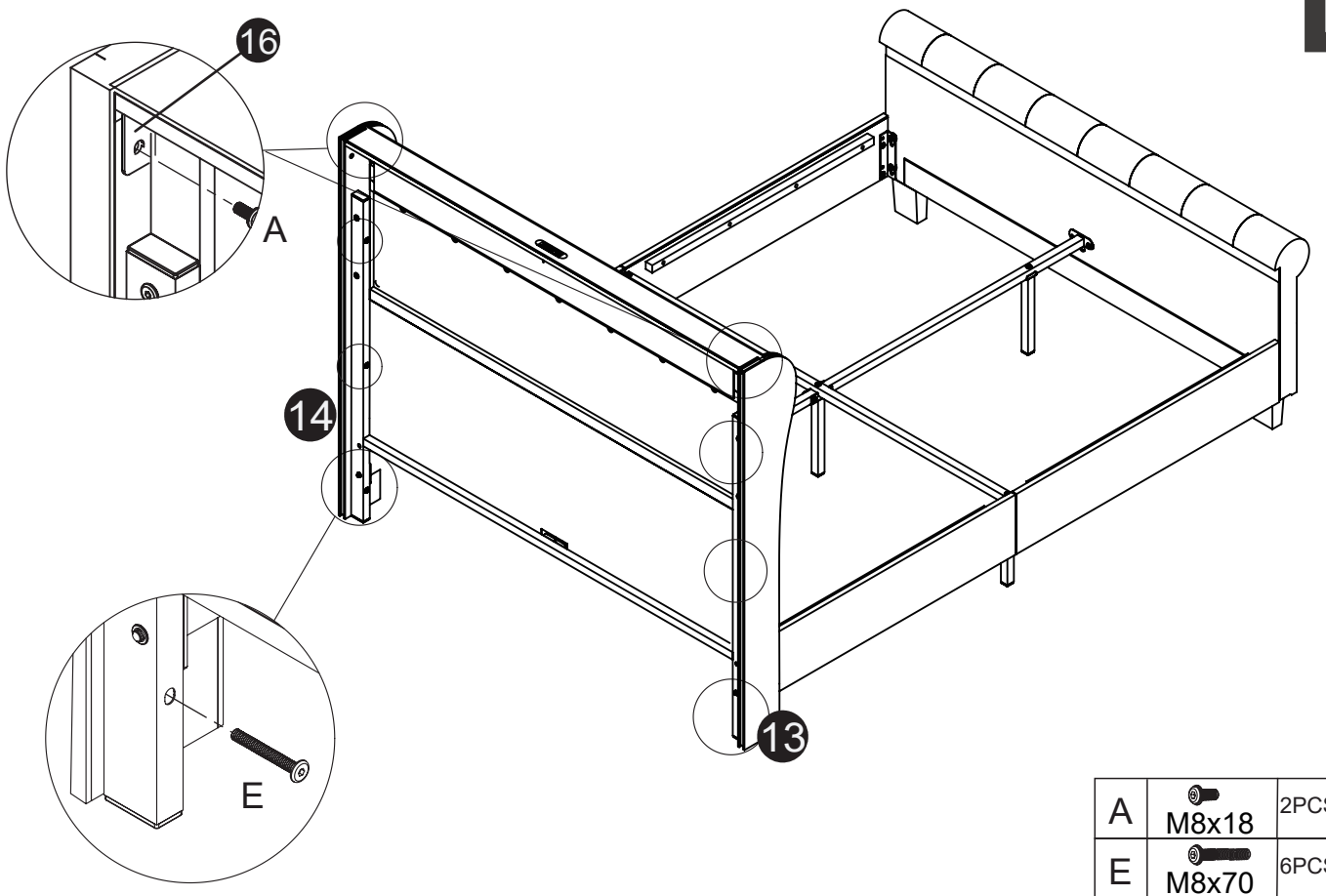
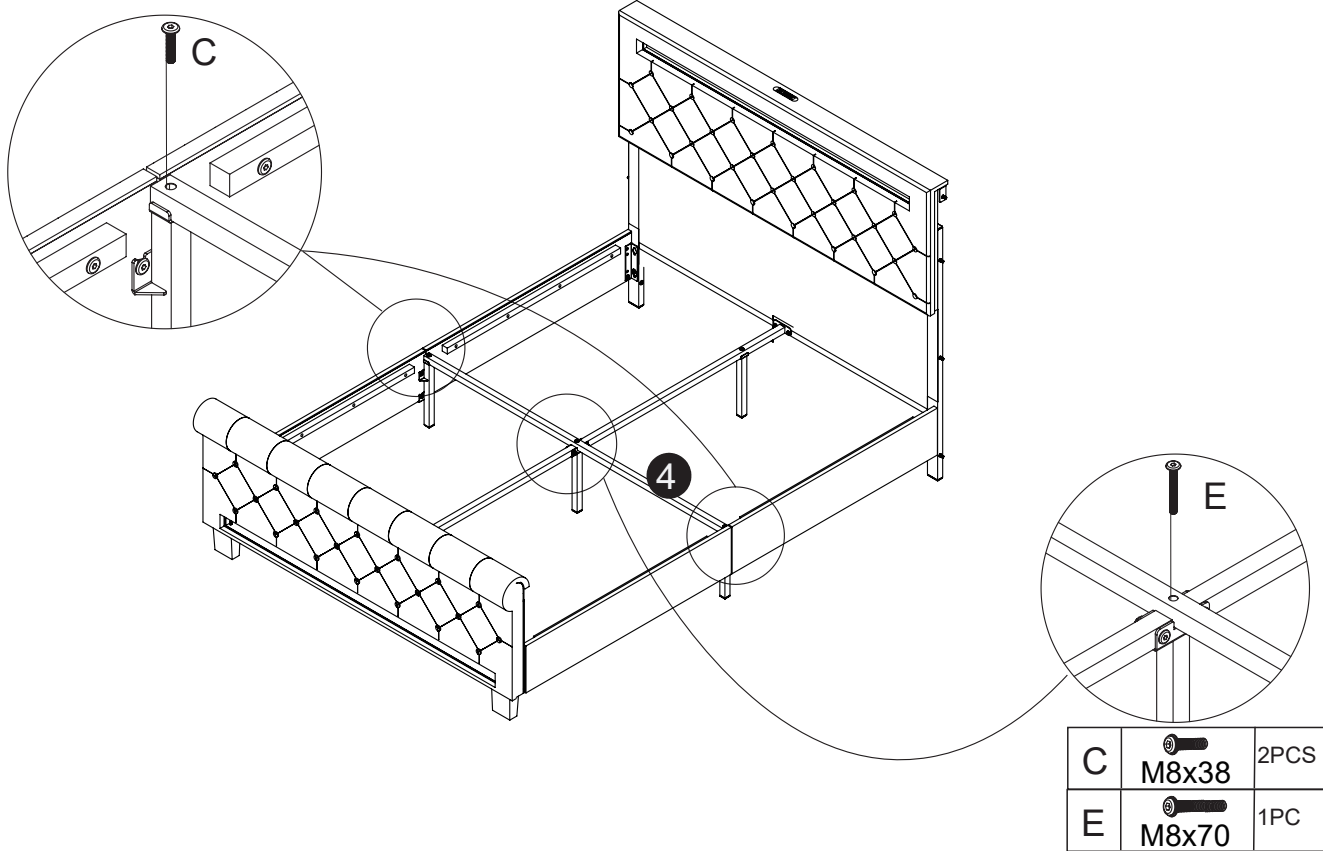

step 1

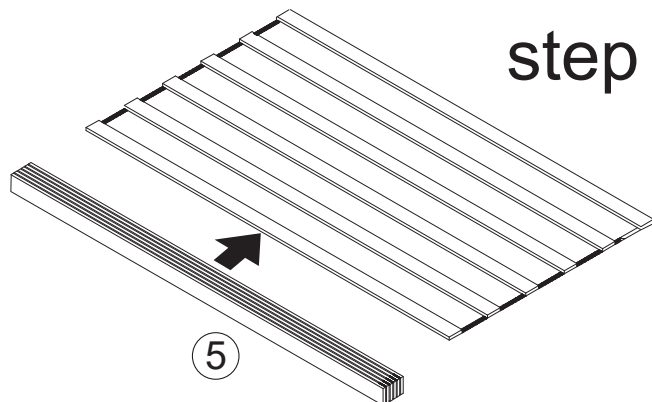

step 2

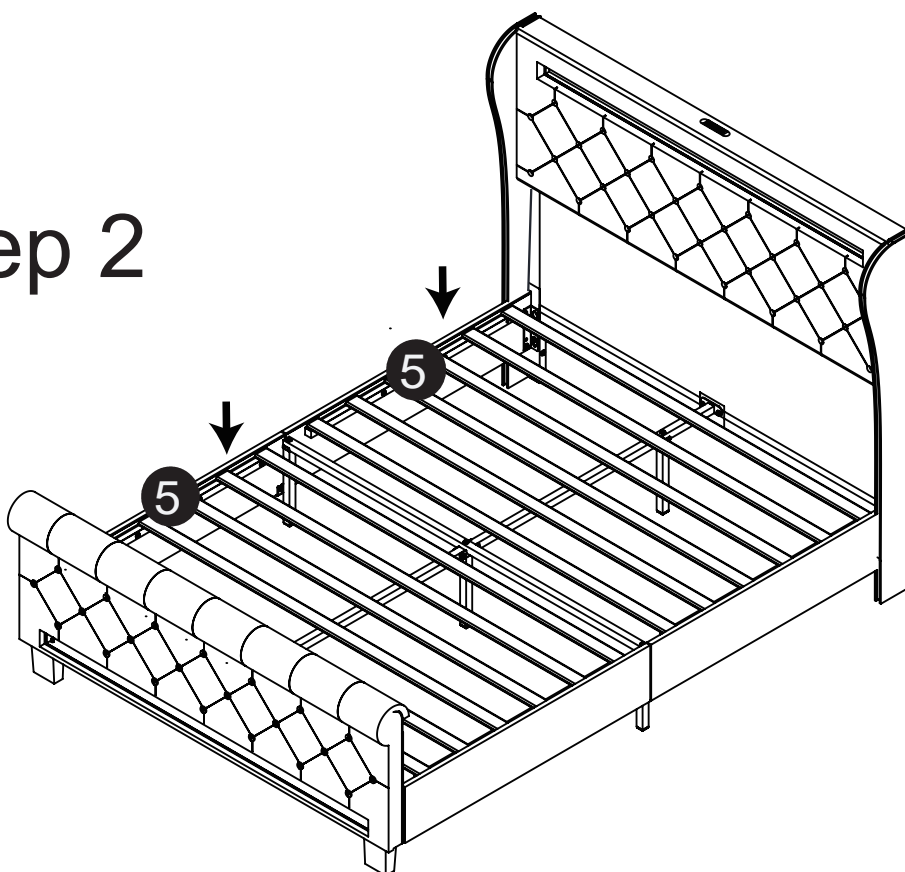

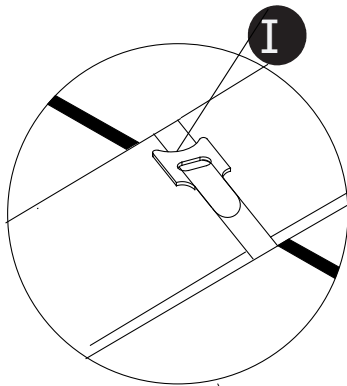

After threading the light strip wires at the bottom of the bed, fix the wires under the keel frame of the bed with bandages ①.

Connect cables from the lights on headboard and footboard with one power cable.

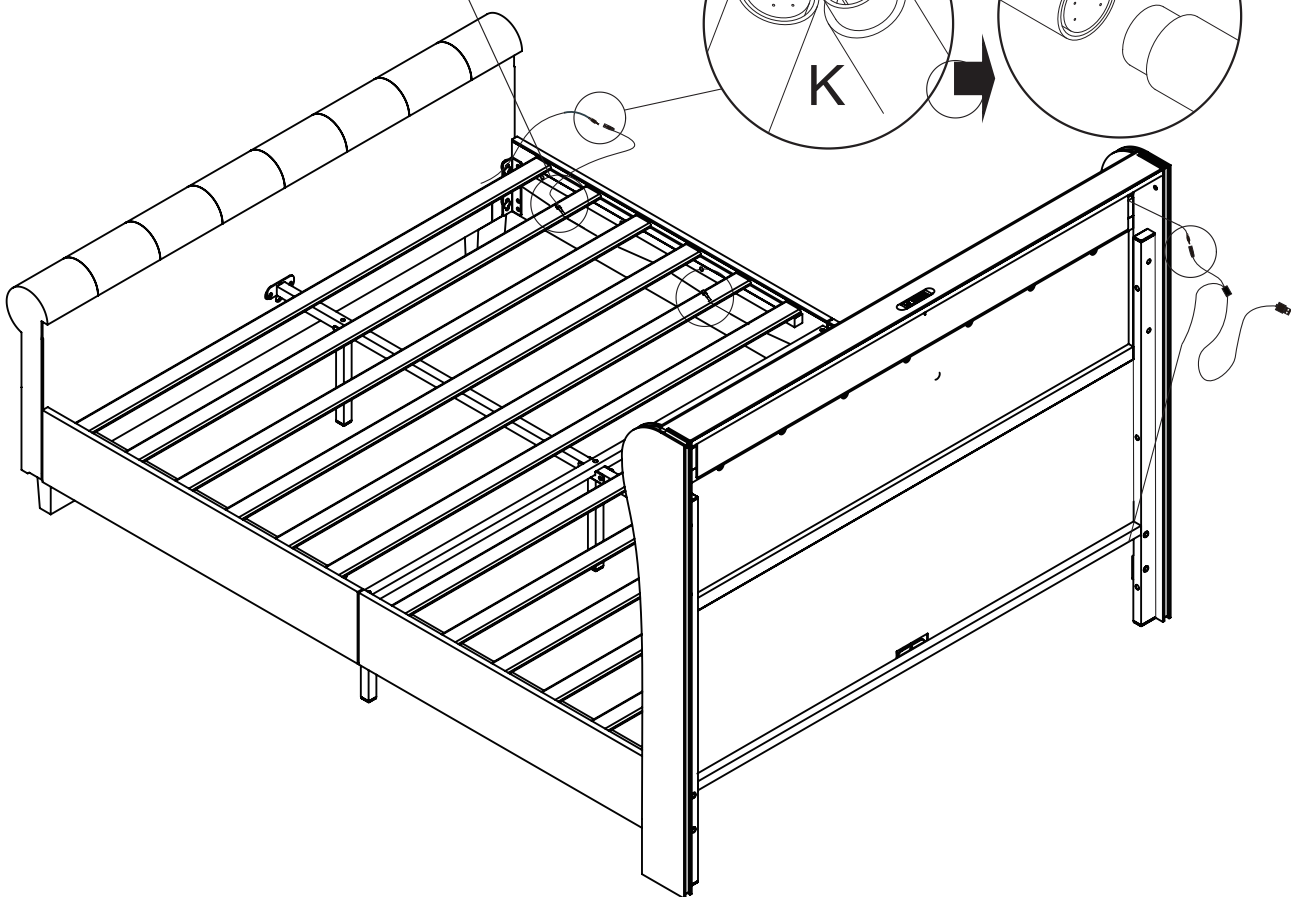
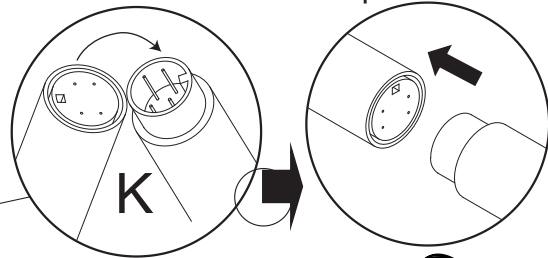

LIMITED WARRANTY

Our team would like to improve the quality of the customer service and make your experience as easy and smooth as possible.

Return Policy: This item could be returned within 30 days without any major reason. After we receive the returned item, we would check it and make sure that it is not damaged. Then we will process the refund. For more details, please remember to check the above terms of RETURN/DAMAGE CLAIM INSTRUCTIONS.

The warranty product is one year from the date of your purchase. If this item is damaged within the warranty period, we will arrange for you the replacement parts free of charge. If the item is damaged for some personal reasons, we could also replace it for you, however, you would need to bear the cost of the replacement parts and shipping fees.

The exceptions or exclusions to this warranty are as follows:

1. Any warranty claim that is submitted after the limited warranty period won't be taken into consideration. We wouldn't be able to replace the item for you even at your cost.
2. This warranty does not cover the products which have been purchased by mistake.

NOTICE:

RETURN/DAMAGE CLAIM INSTRUCTIONS:

-If the package is damaged, please contact us as soon as possible and attach the damaged photo.

-Return Policy: This item can be returned within 30 days without any reason. If you return this item for personal reasons, you need to bear the freight of returns and order processing fee (0-50% restocking fee based on the invoice price). If the product has quality issues (not caused by humans), we will bear the freight.

-If you need to return the goods, please keep the original box. Please make sure to use the return label provided by us and do not return it without permission. Please do not share a label with multiple boxes.

-If you return the product after 30 days from receiving it, we are afraid that your return application won't be accepted. We appreciate your understanding.

-The warranty product is one year. If this item is damaged within the warranty period we will arrange you the replacement parts free of charge. If the item is damaged for some personal reasons, we could also replace it for you, however you need to bear the transport fees.