

Assembly Instructions

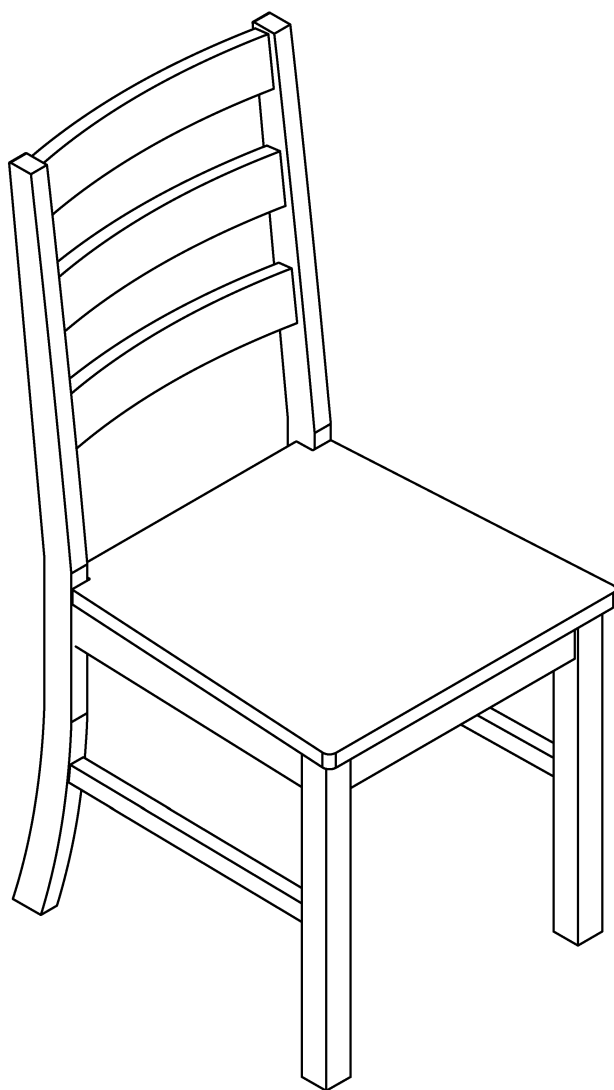

© 2010 The Home Depot. All rights reserved. Home Depot is a registered trademark of The Home Depot.

10-10-10

General Assembly Guidelines

- I. Ensure that all parts and hardware are available before beginning assembly.
- II. Follow each step carefully to ensure the proper assembly of this product.
- III. Two people are recommended for ease in the assembly of this product.
- IV. The three main types of hardware used to assemble this product are : wood dowels , screws and bolts.
- V. A Phillips head screwdriver is required for the assembly of this product .

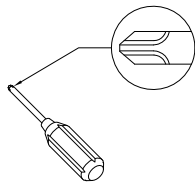



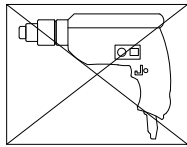

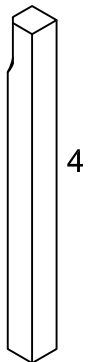
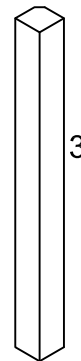
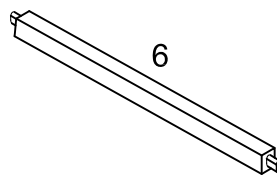
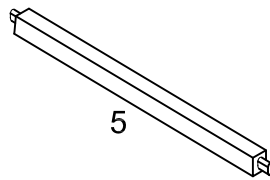
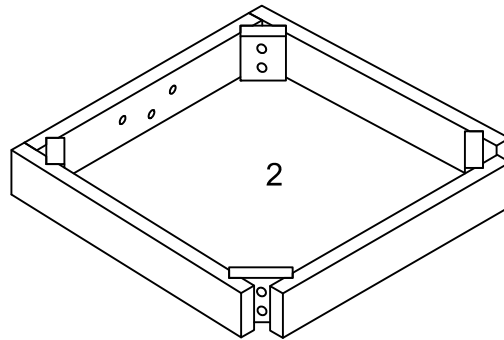
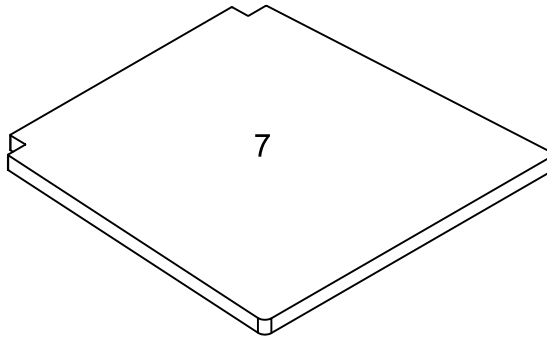
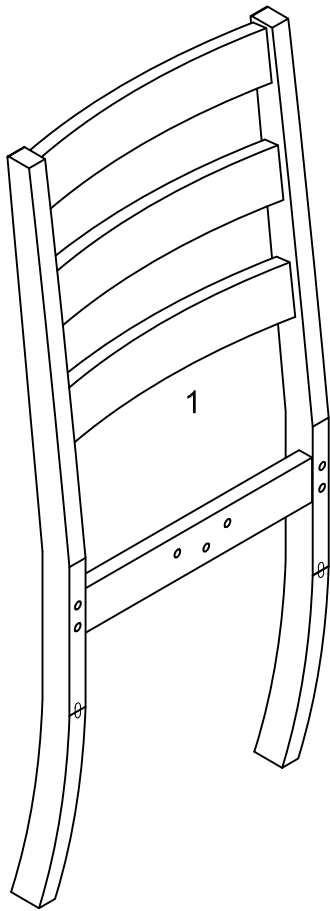

- VI. Power tools should not be used to assemble this product .



Parts List

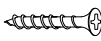

Hardware List

A		M6x80mm	Bolt	4 pcs
B		M6x60mm	Bolt	4 pcs
C		M6x35mm	Bolt	3 pcs
D		Ø1/4 "	Spring washer	11 pcs
E		Ø1/4 "	Washer	11 pcs
F		M4 x 32	Screw	8 pcs
G		M4	Wrench	1 pc

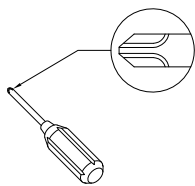

Philips head screwdriver required for assembly
(not included)

*The hardware quantities listed above are required for proper assembly.
Some extra hardware may also have been included.*

Step 1

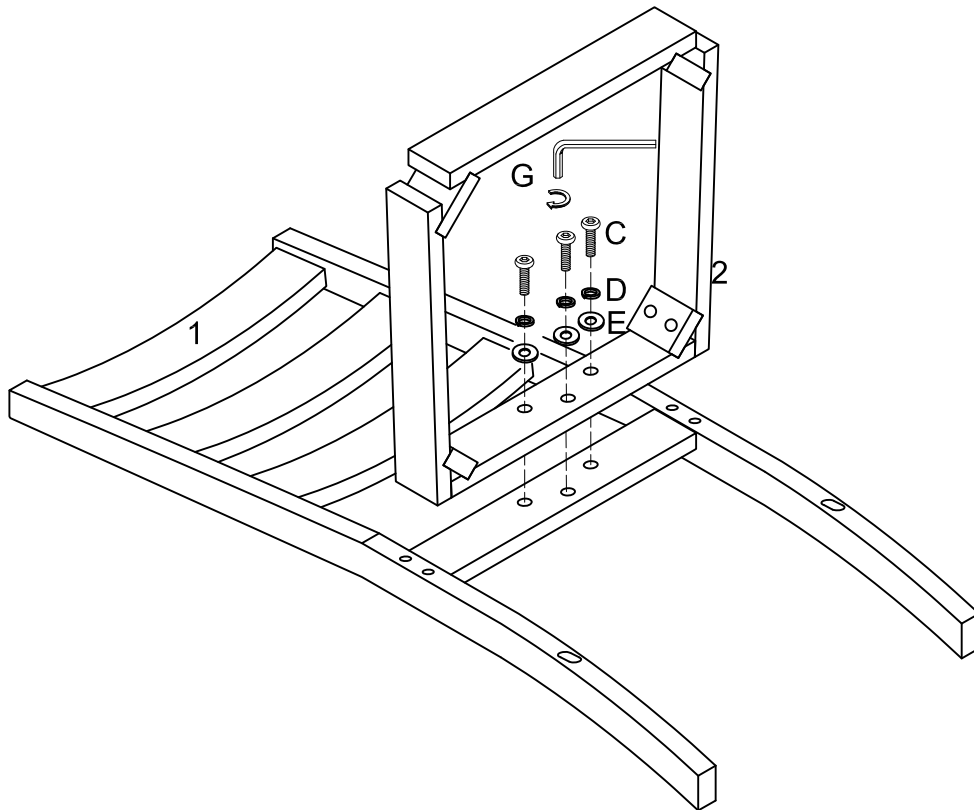

Use wrench (G) to secure seat frame (2) to back frame (1) with bolt (C), spring washer (D) and washer (E).

Step 2

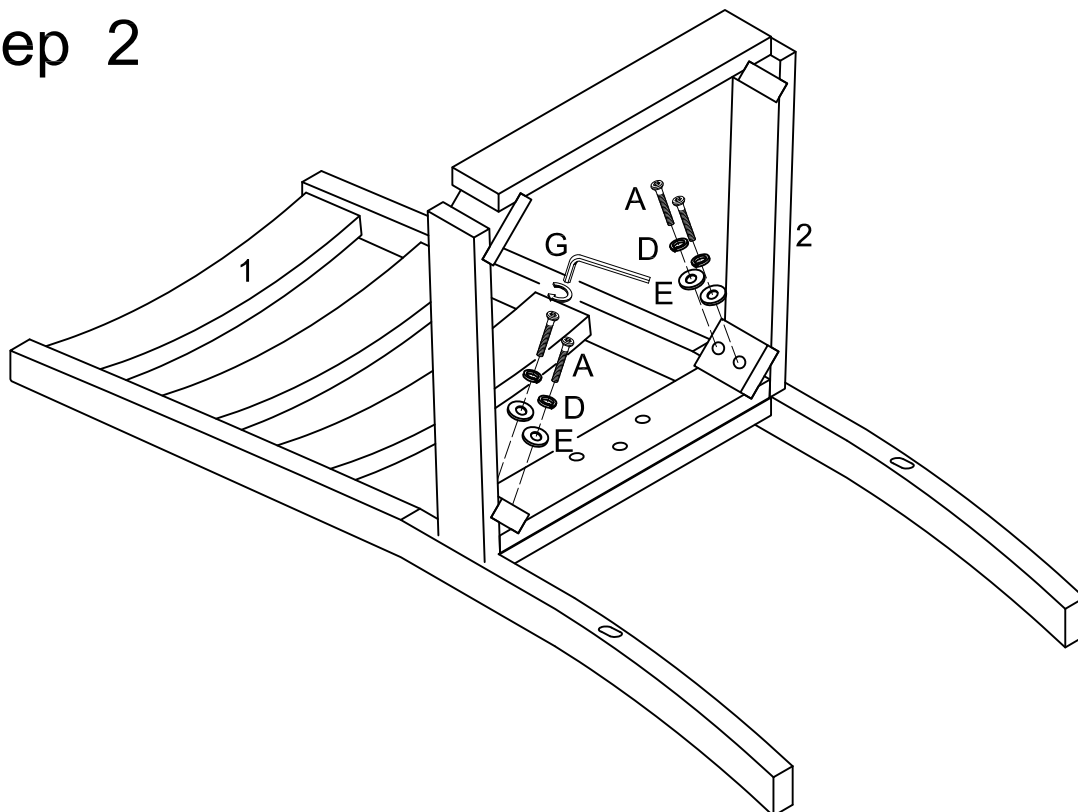

Use wrench (G) to secure seat frame (2) to back frame (1) with bolt (A), spring washer (D) and washer (E).

Step 3

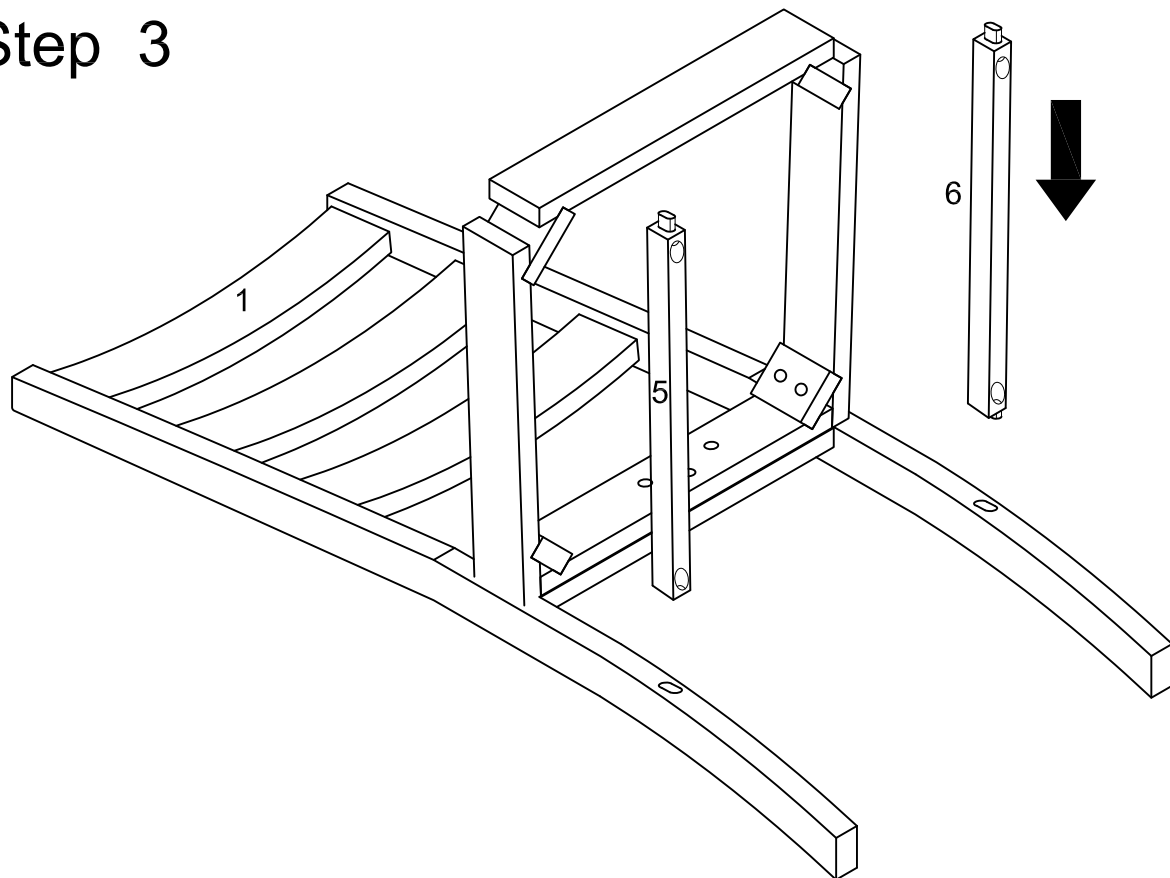

Insert support bar (5,6) into back frame (1).

Step 4

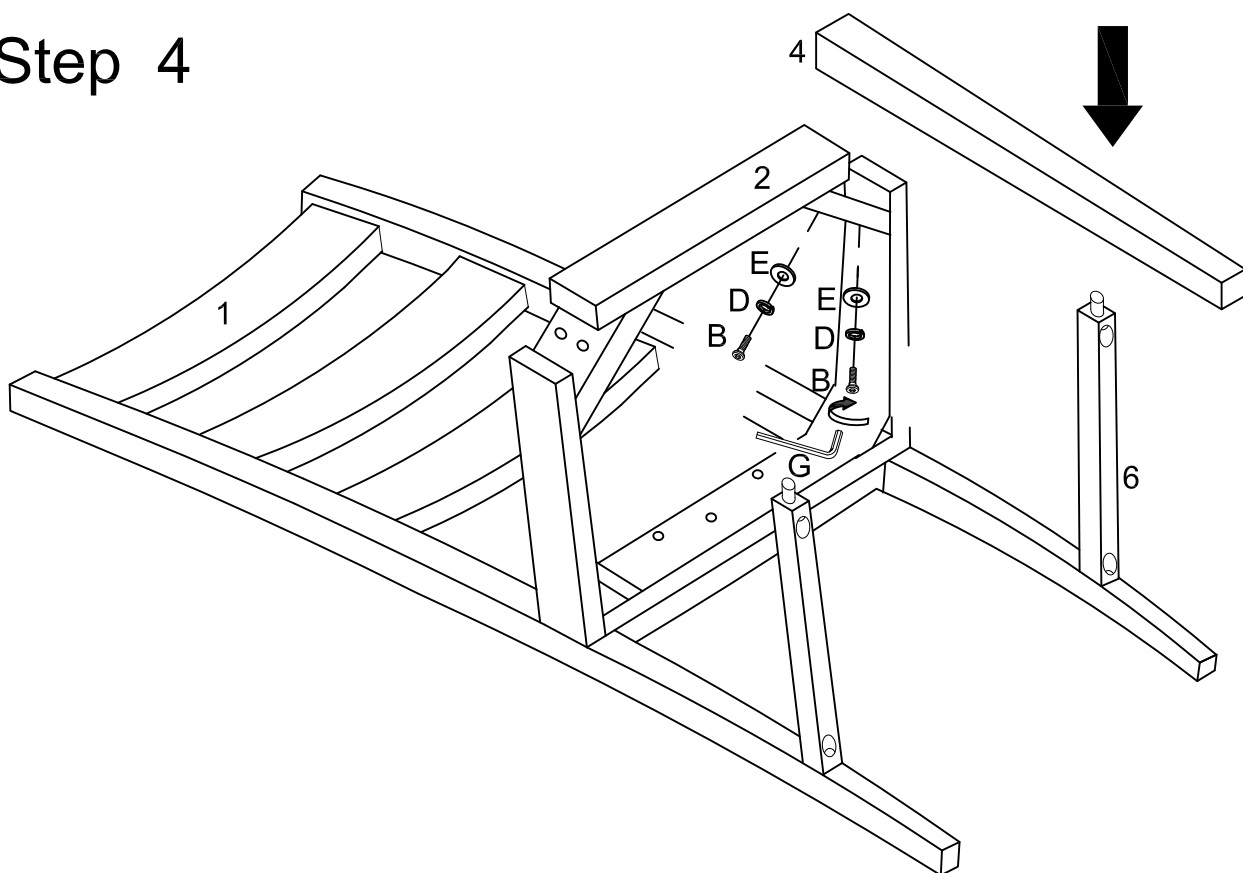

Insert leg (4) into support bar (6), use wrench (G) to secure seat frame (2) to leg (4) with bolt (B), spring washer (D) and washer (E).

Step 5

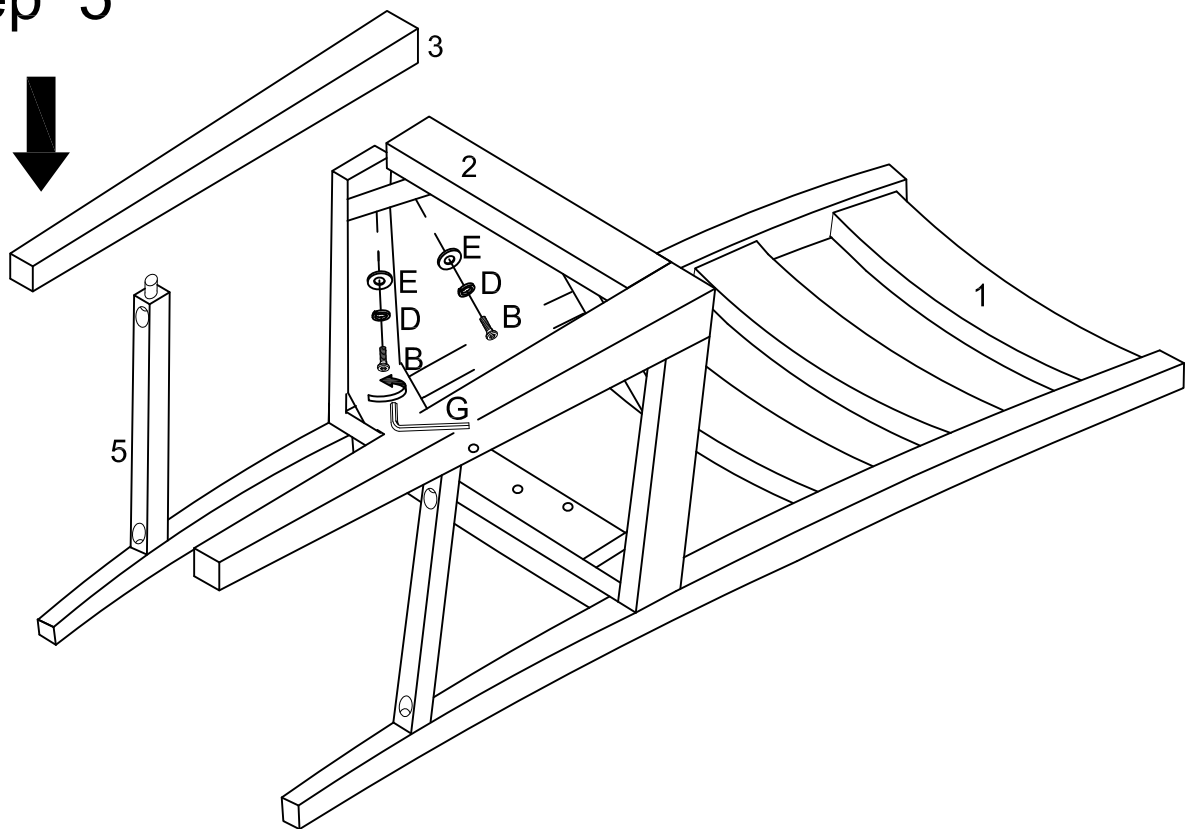

Insert leg (3) into support bar (5), use wrench (G) to secure seat frame (2) to leg (3) with bolt (B), spring washer (D) and washer (E).

Step 6

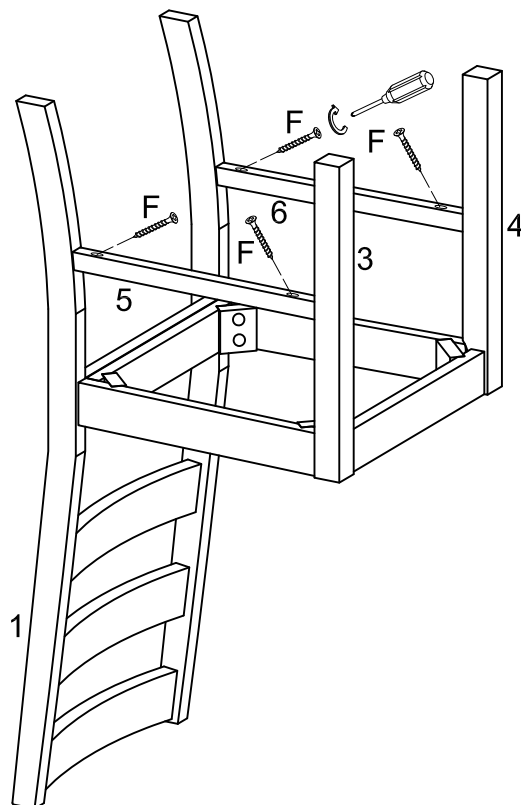

Secure support bar (5,6) to leg (3,4) with screw (F).

Step 5

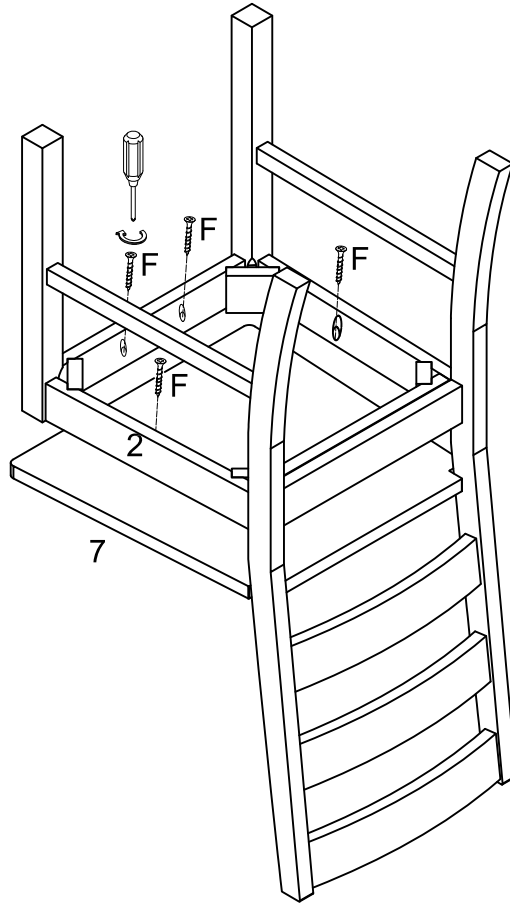

Secure seat frame (2) to seat panel (7) with screw (F).

Step 6

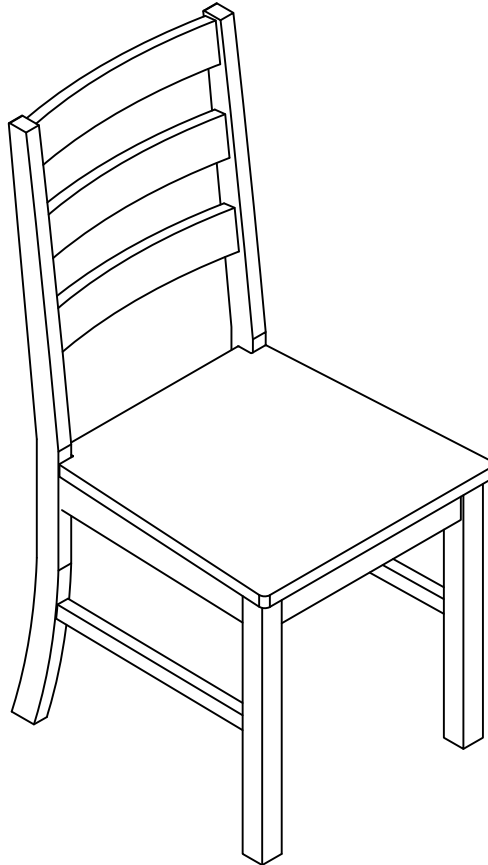

Final Assembly