

# ASSEMBLY INSTRUCTIONS

ITEM NO.:N719P380279

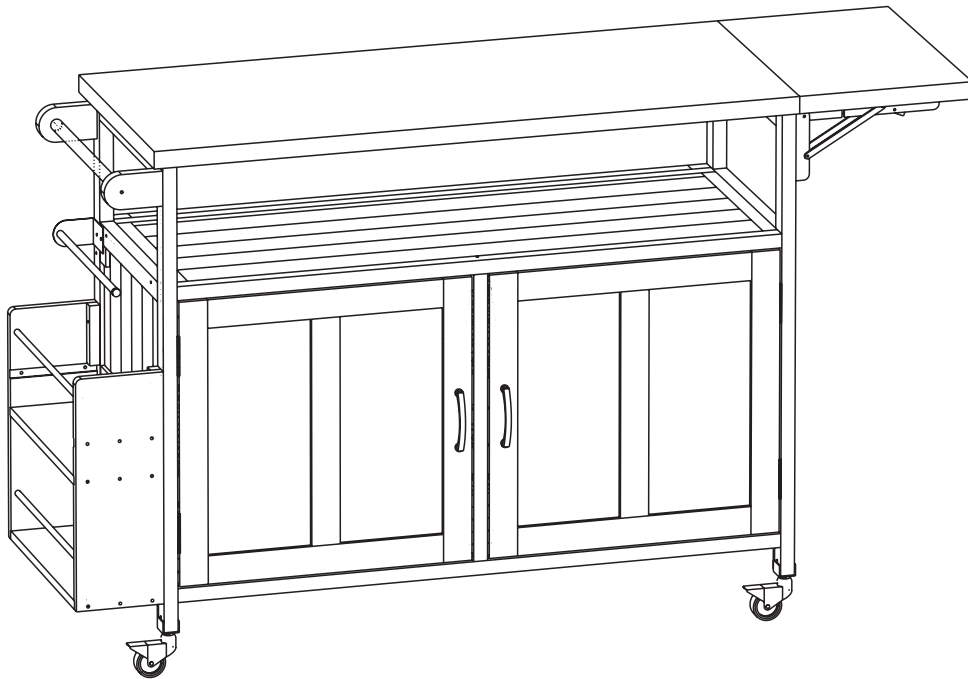





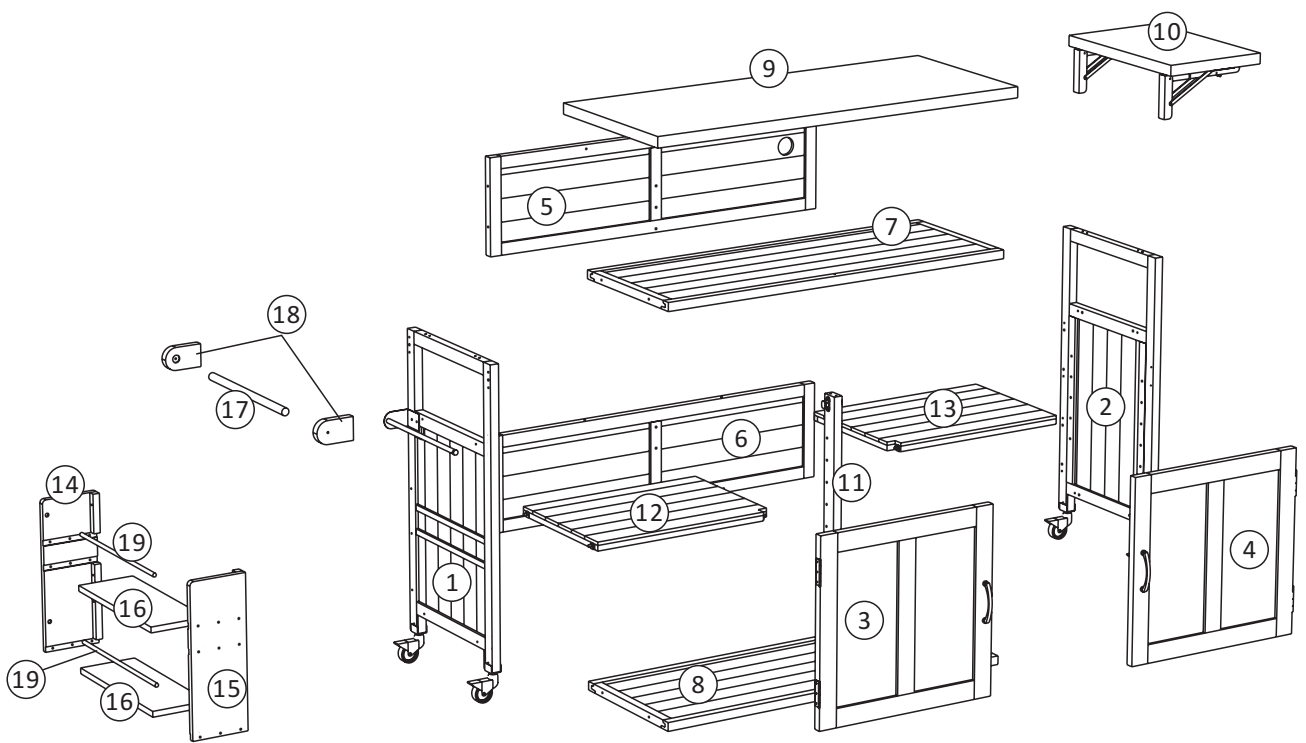

## IMPORTANT NOTE:

- ① PLACE ALL PARTS ON A CLEAN AND SMOOTH SURFACE SUCH AS A RUG OR CARPET TO AVOID THE PARTS FROM BEING SCRATCHED.
- ② BEFORE YOU BEGIN, KINDLY FOLLOW THE ASSEMBLY INSTRUCTIONS STEP BY STEP.
- ③ DO NOT TIGHTEN ALL SCREWS AND BOLTS UNTIL THIS ITEM IS FULLY SET-UP.

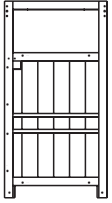
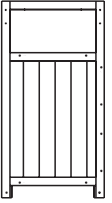
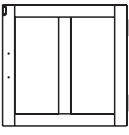
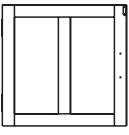
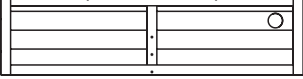
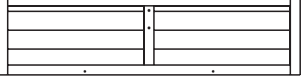
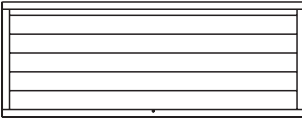
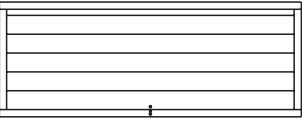



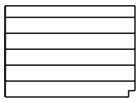
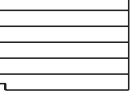
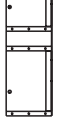
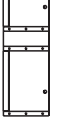
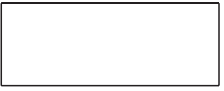
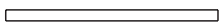











# Detail View



# N719P380279

1		2		3		4	
	1x		1x		1x		1x
5		6		7		8	
	1x		1x		1x		1x
9		10		11		12	
	1x		1x		1x		1x
13		14		15		16	
	1x		1x		1x		2x
17		18		19			
	1x		2x		2x		

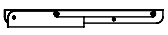
## Hardware List

A	 Ø 3.5*60 4x	B	 Ø 3.5*45 22x	C	 Ø 3.5*40 10x	D	 Ø 3.0*28 12x		
E	 Ø 3.5*25 10x	F	 Ø 3.0*16 12x	G	 Ø 3.0*18 2x	H	 Ø 4.0*35 4x		
I	 Ø 6.0*30 2x	J	 28x	K	 8x	L	 2x		
M	 1x	N	 4x	O	 2x	P	 1x	Q	 1x

ASSEMBLY TOOLS REQUIRED( NOT INCLUDED)



PLEASE BE CAREFUL DO NOT DAMAGE THE HOLE POSITION WHEN YOU USE POWERTOOLS !

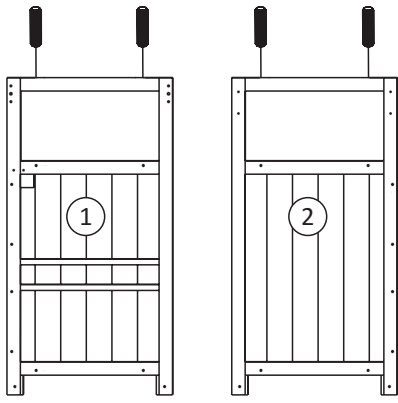

J\*10

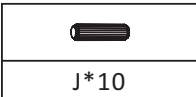
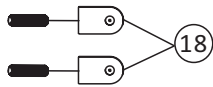
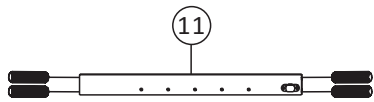

1

2

J\*8

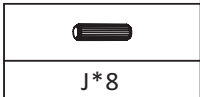
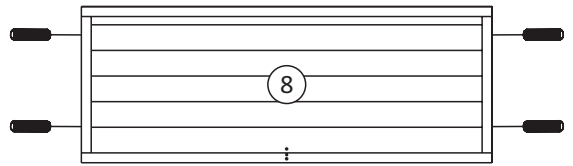
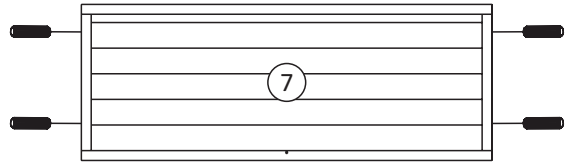

J\*8

J\*10

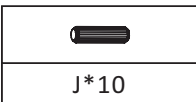
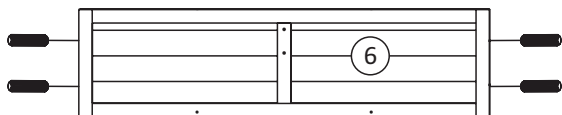
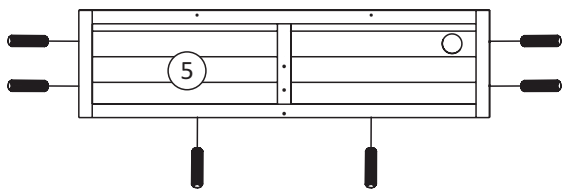

3

4

B\*4  
I\*2

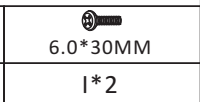
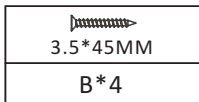
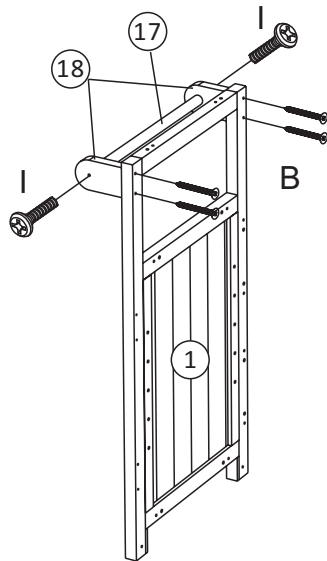

B\*2

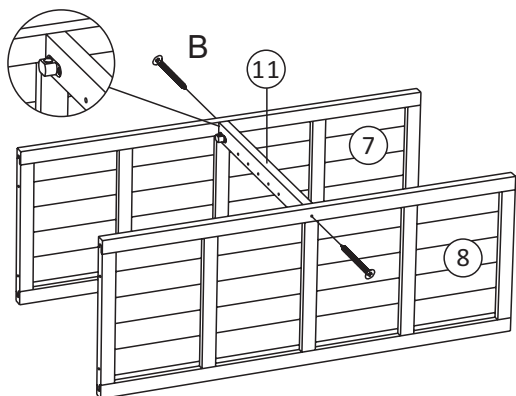

5

 3.5\*45MM

B\*2

B\*4

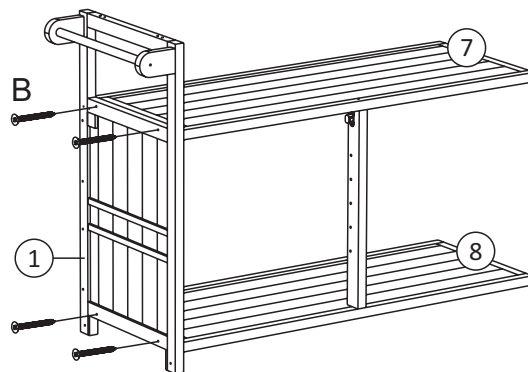

6

 3.5\*45MM

B\*4

B\*4  
C\*4  
M\*1

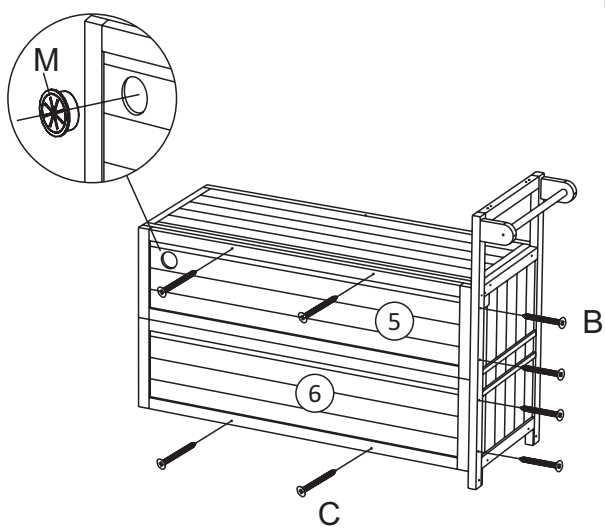

7

 3.5\*45MM

B\*4

 3.5\*40MM

C\*4



M\*1

B\*8

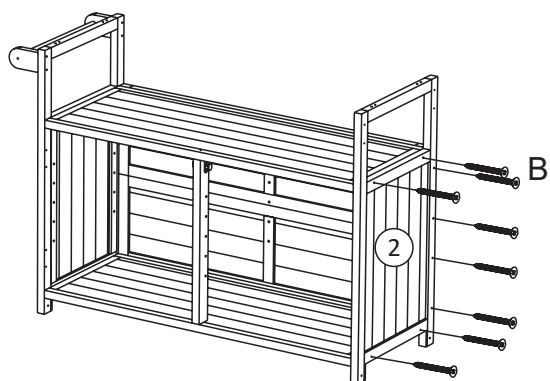

8

 3.5\*45MM

B\*8

K\*8

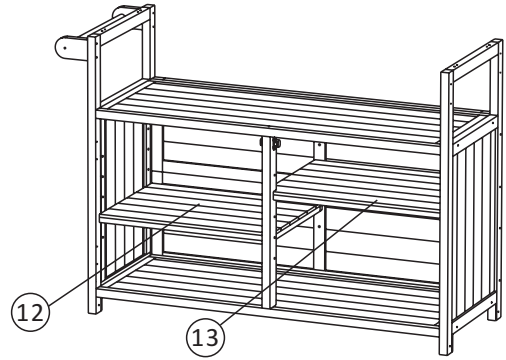
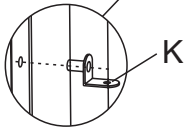
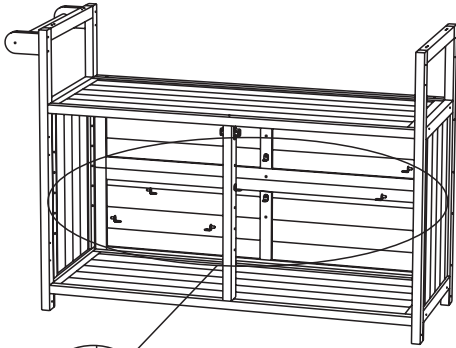

9



K\*8

10

F\*12  
L\*2

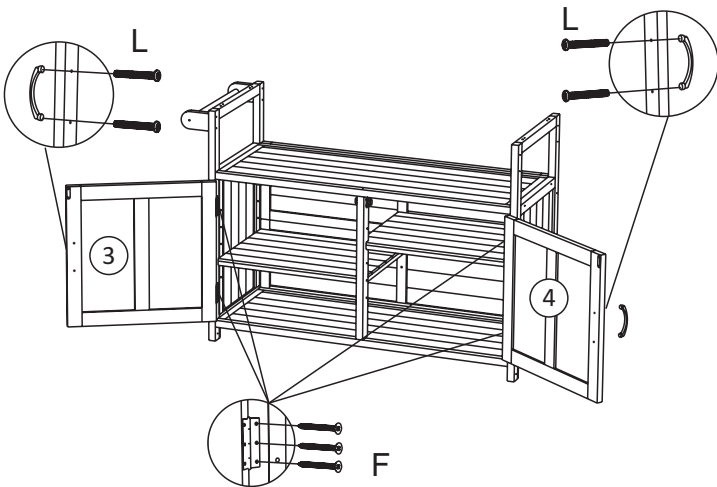

D\*12

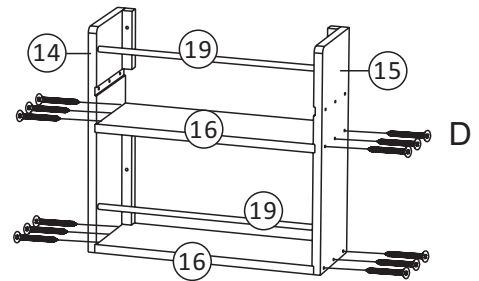

11

3.0\*16MM

F\*12



L\*2

12

3.0\*28MM

D\*12

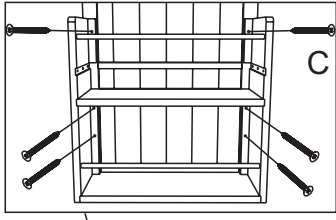

C\*6

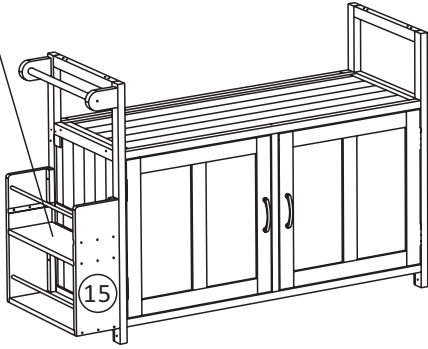

15

13

3.5*40MM
C*6

14

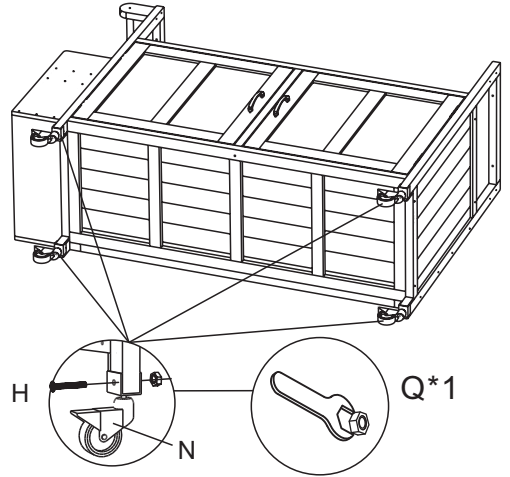

H\*4  
N\*4



H

N

Q\*1

		
4.0*35MM		
H*4	N*4	Q*1

A\*4

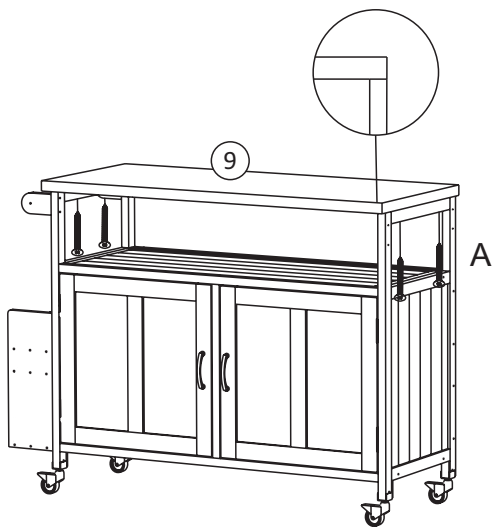

9

A

15

3.5*60MM
A*4

16

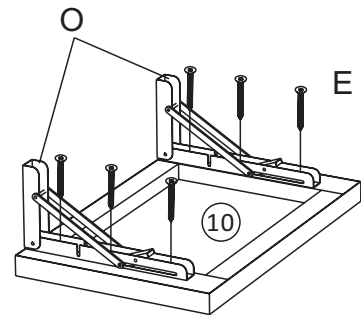

E\*6  
O\*2



O

E

10

	
3.5*25MM	
E*6	O*2

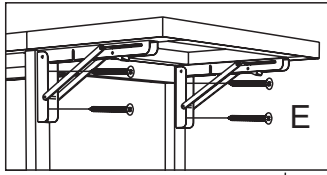

E\*4

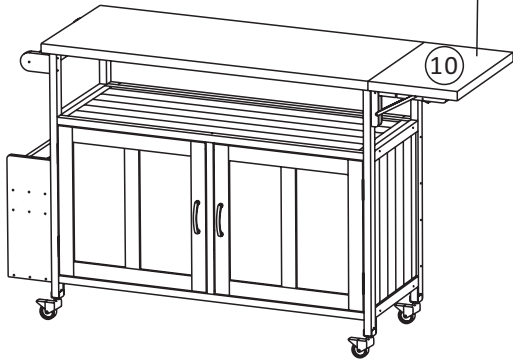

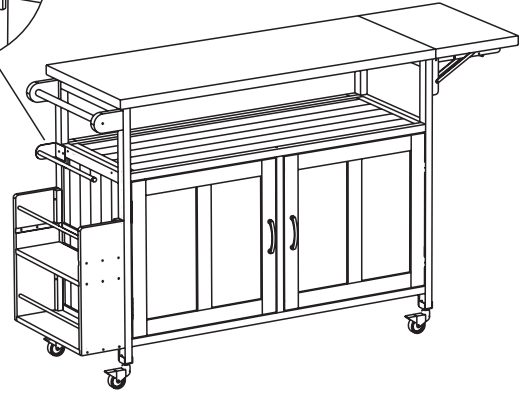
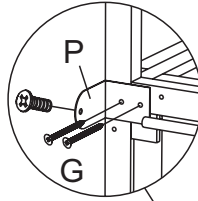

G\*2  
P\*1



18

3.5*25MM
E*4

18

	
3.0*18MM	
G*2	P*1

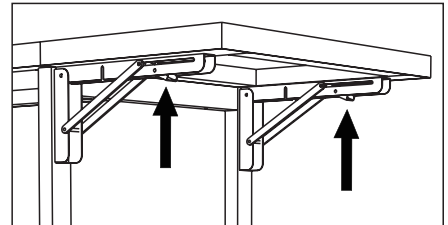
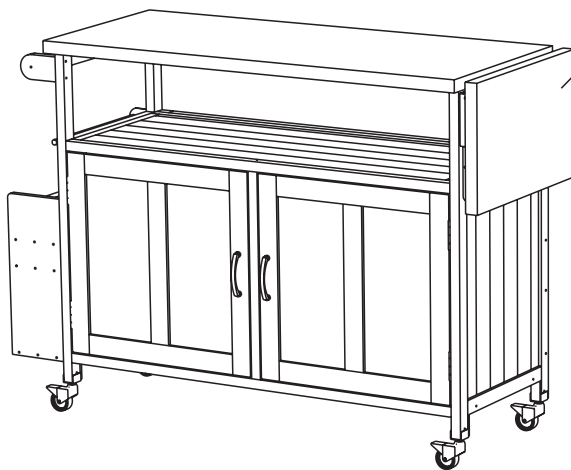

**Warning**  
Mind your hands.

19