

# Table

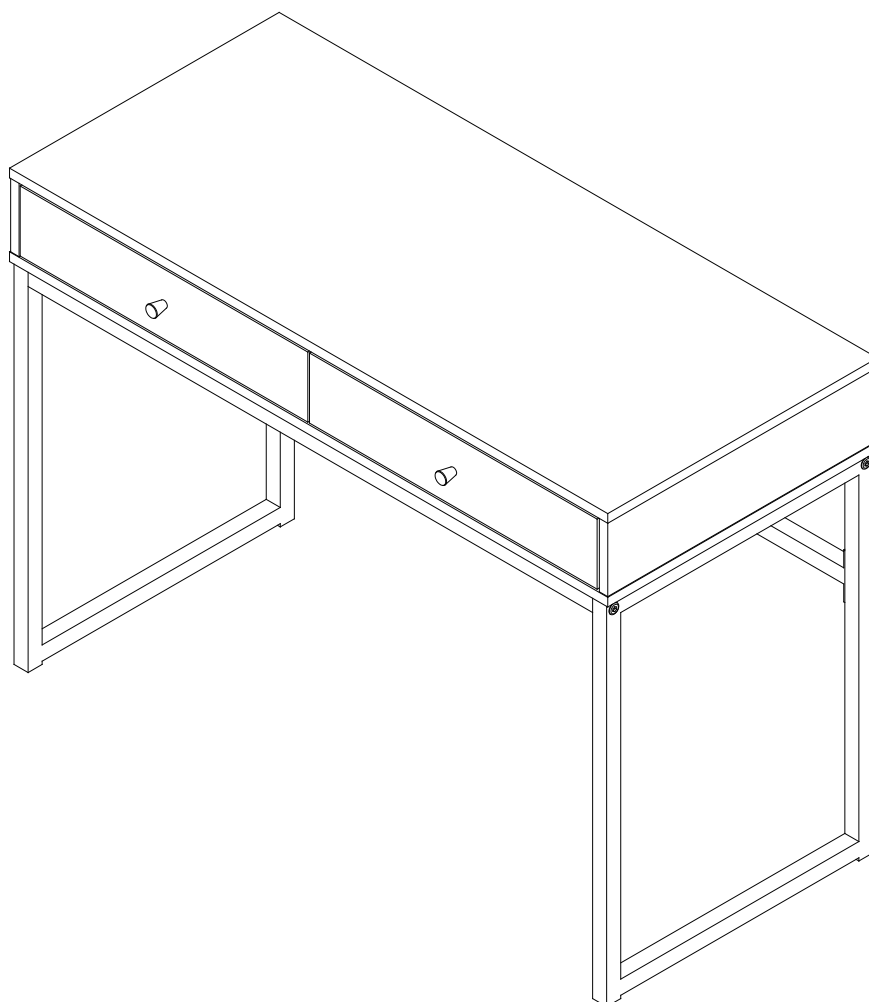



Estimated time for assembly:

**45 mins**



Weight limitations are as follows:

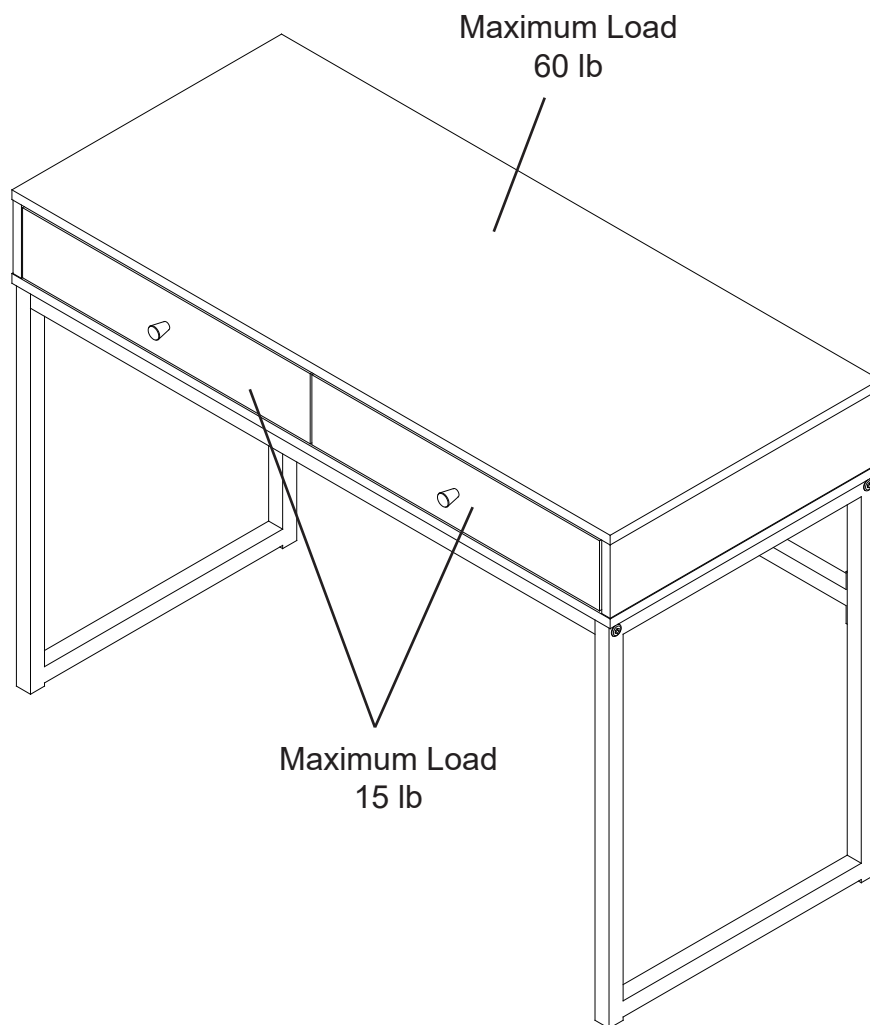

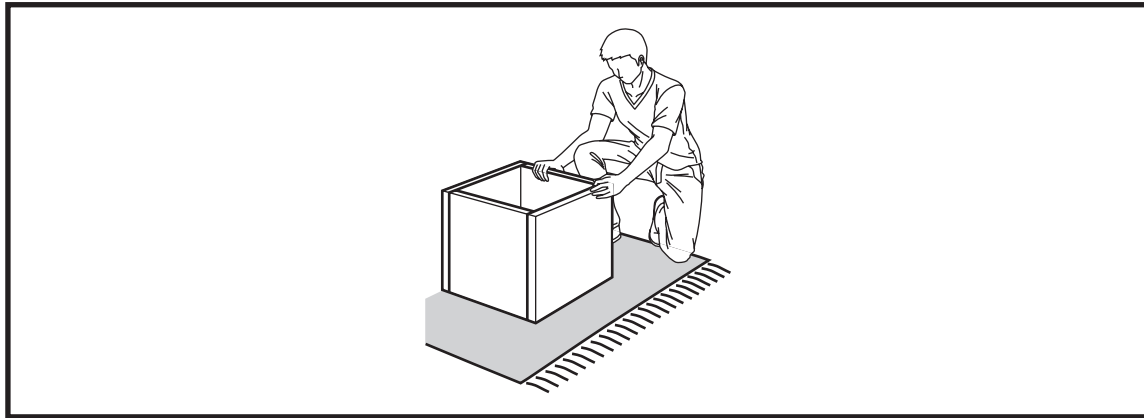

Assemble the furniture on an empty carton, carpet, or rug to prevent scratches or damage.

For safety, please keep pets and children away from the assembly area.

Ensure the product is fully assembled before use. If you are missing any hardware or products, do not use it until you have restored the missing parts.

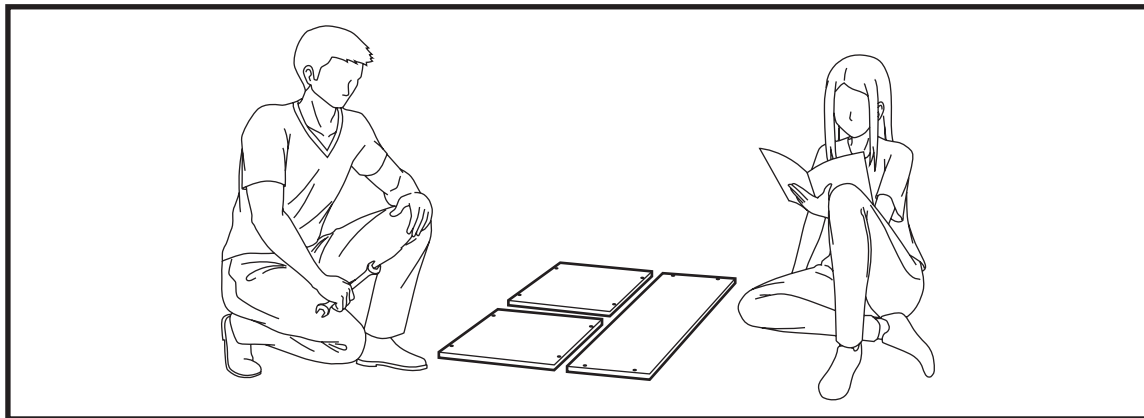

This furniture requires 2 people for assembly.

Read this instruction manual prior to assembly to familiarize yourself with the various steps.

Lay out all components and hardware separately on a flat surface and make sure that no parts are missing or damaged before assembly. Do not destroy or discard any packaging until you are certain that you have all the necessary parts for assembly.

Hand tight all hardware and careful not to over tighten to avoid damaging the product.

## **CAUTION**

There are small components used in the construction of this product. Loose items should be kept away from pets and children to avoid a choking hazard.

Keep all plastic bags and packaging film away from pets and children to avoid suffocation.

# PACKAGE CONTENTS

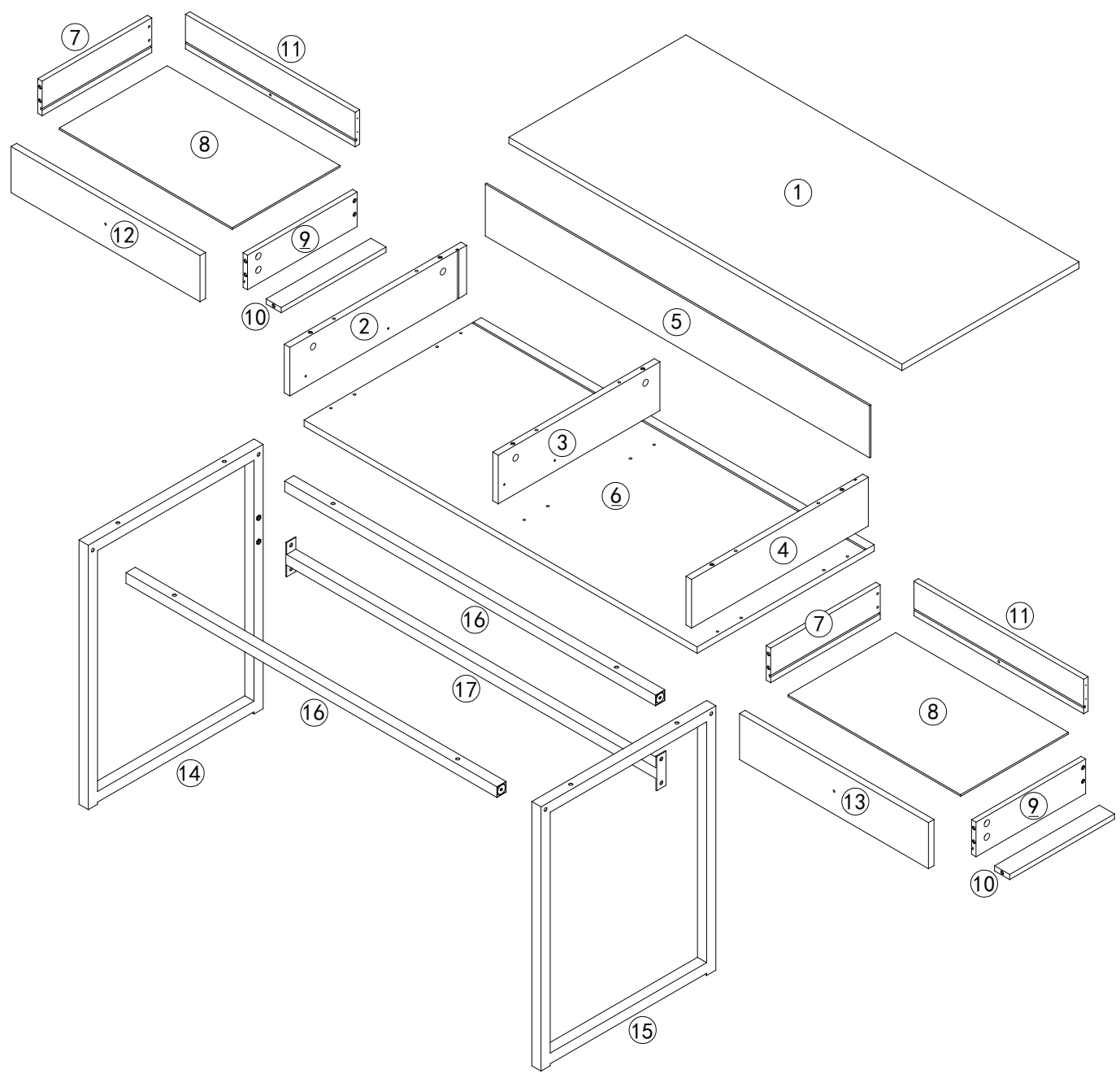

## PACKAGE CONTENTS

CODE	DESCRIPTION	QTY
1	Table Top	1
2	Left Panel	1
3	Divider Panel	1
4	Right Panel	1
5	Back Panel	1
6	Bottom Panel	1
7	Drawer Left Panel	2
8	Drawer Bottom Panel	2
9	Drawer Right Panel	2
10	Drawer Support Strip	2
11	Drawer Back Panel	2
12	Left Drawer Front Panel	1
13	Right Drawer Front Panel	1
14	Left Frame	1
15	Right Frame	1
16	Crossbar	2
17	Center Crossbar	1

# PACKAGE CONTENTS

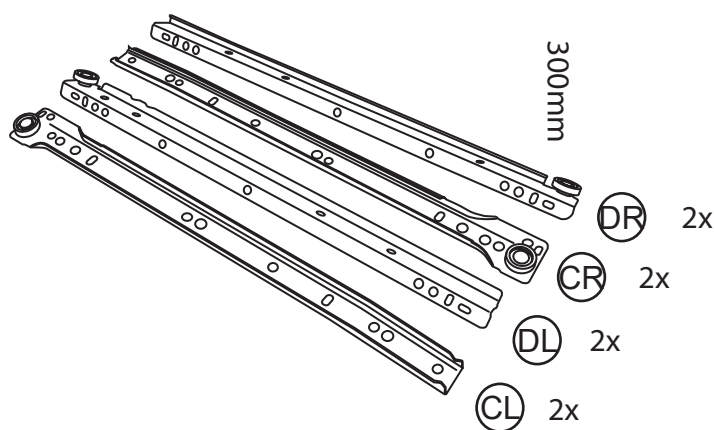
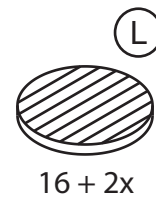
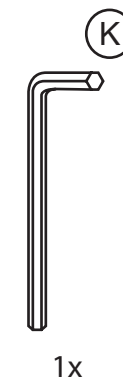
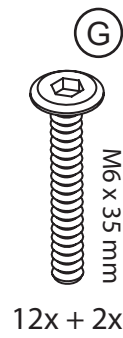
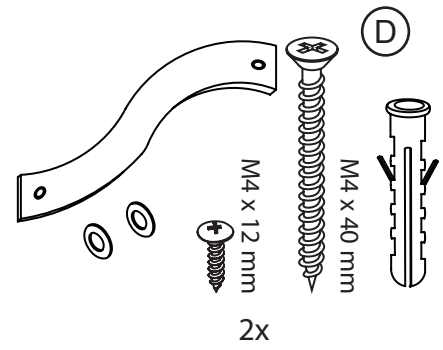
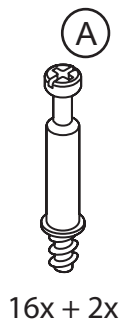

Install all hardware perpendicular to the opening.

Required tools for assembly (Not included)

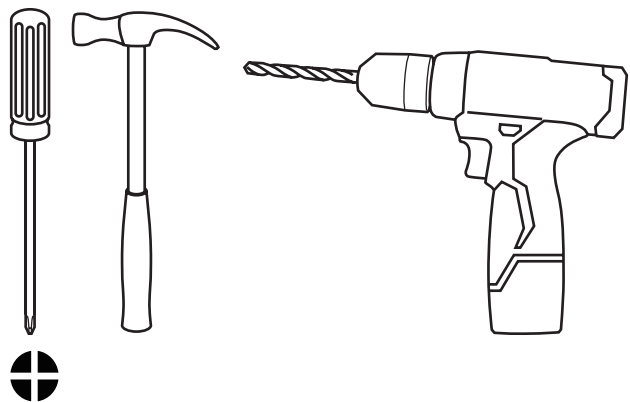

**1**

Attach cam bolts to the table top (1).

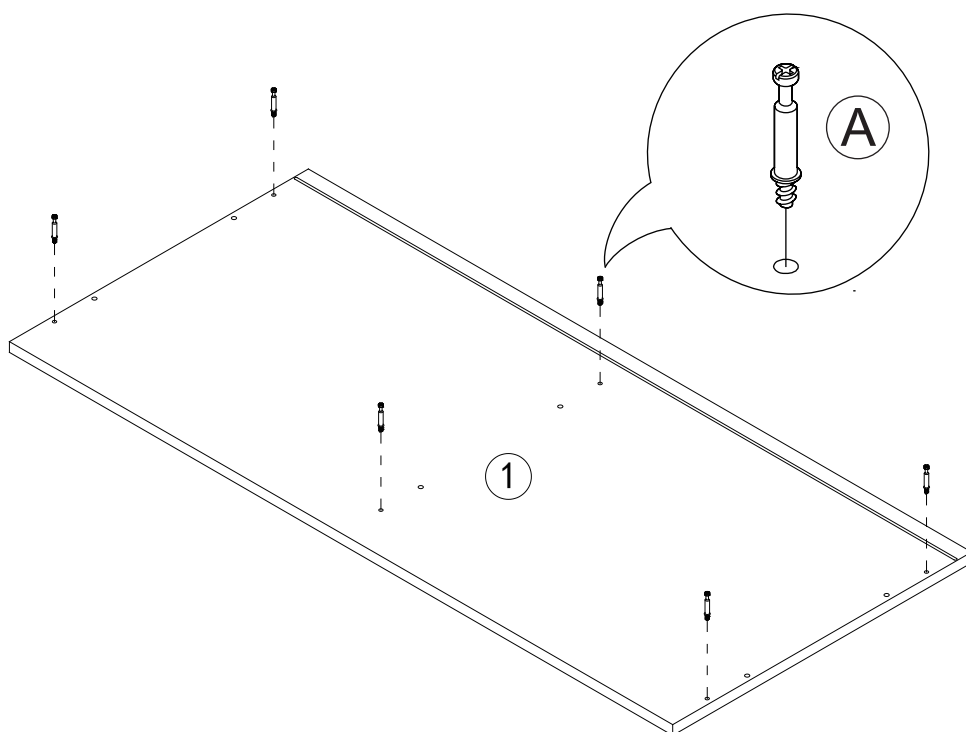
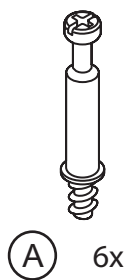

# 2

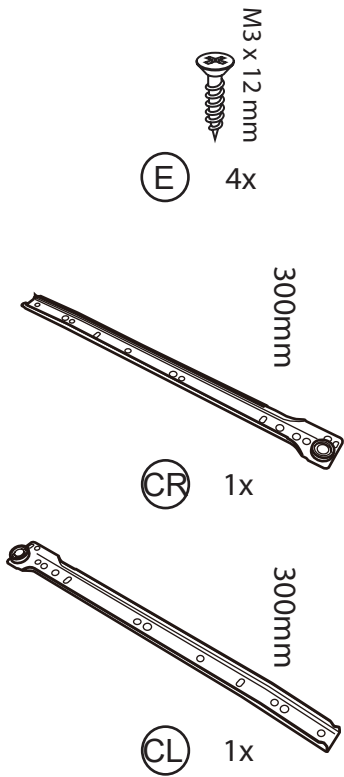

Attach drawer slide bracket to the left and right panels (2, 4).

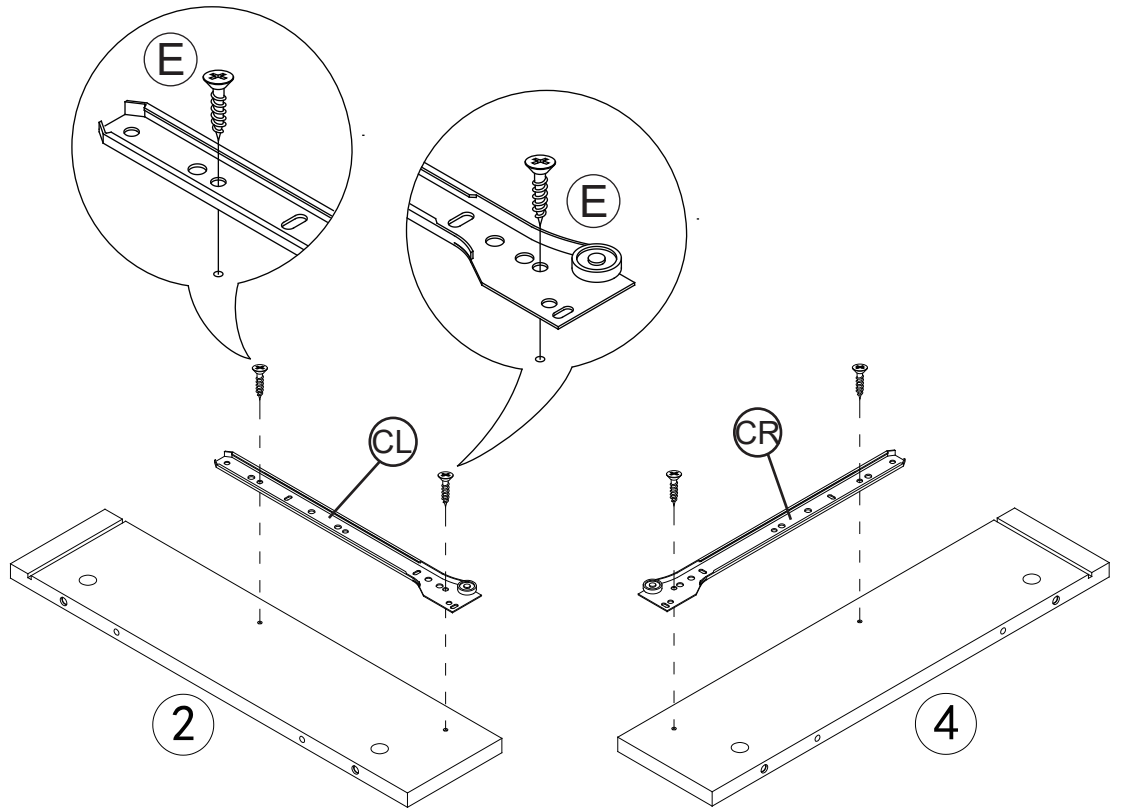

# 3

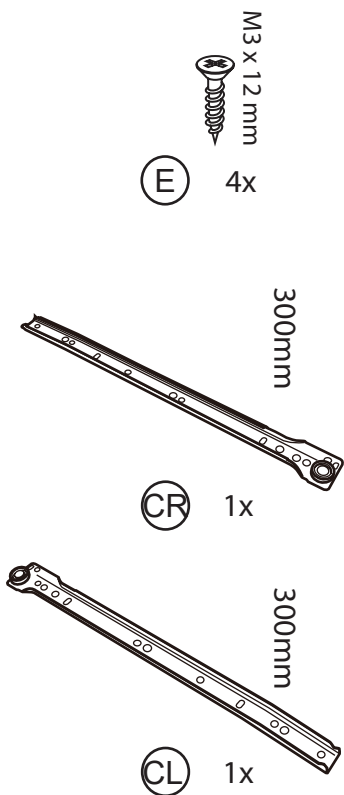

Attach drawer slide brackets to both sides of the divider panels (3).

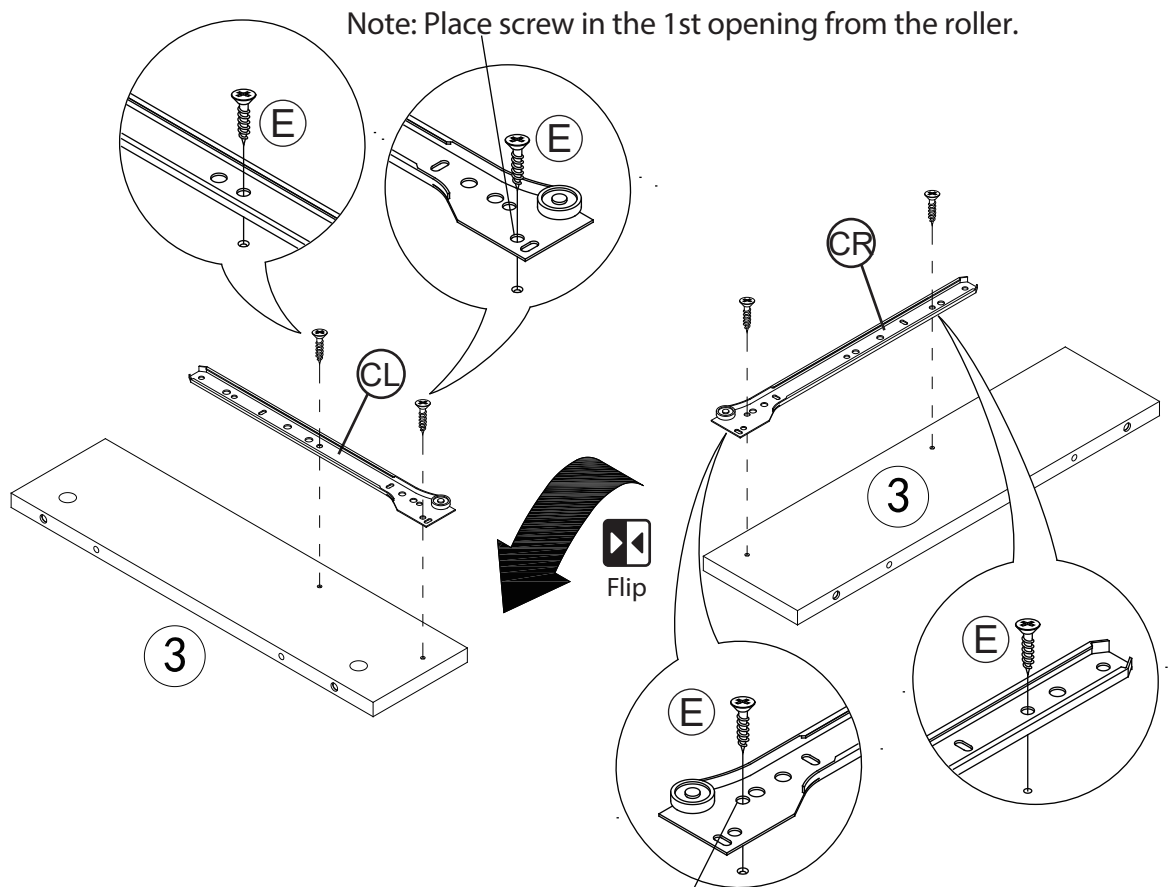

# 4



Insert wood dowels to the table top (1).

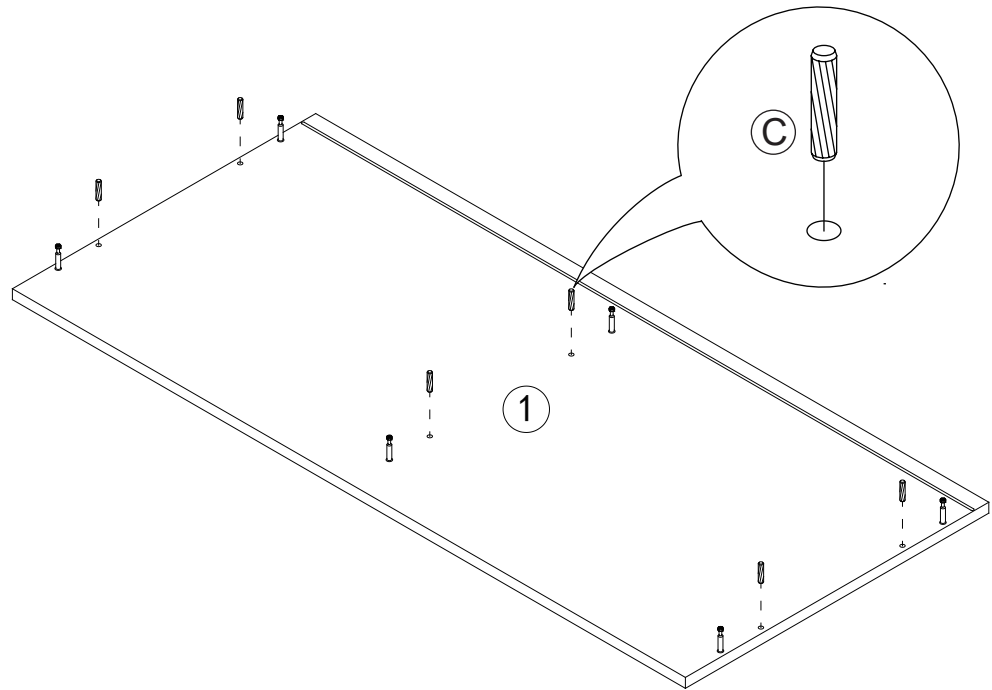

# 5

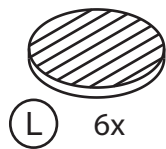

Assemble the left panel (2), divider panel (3), and right panel (4) to the table top (1).

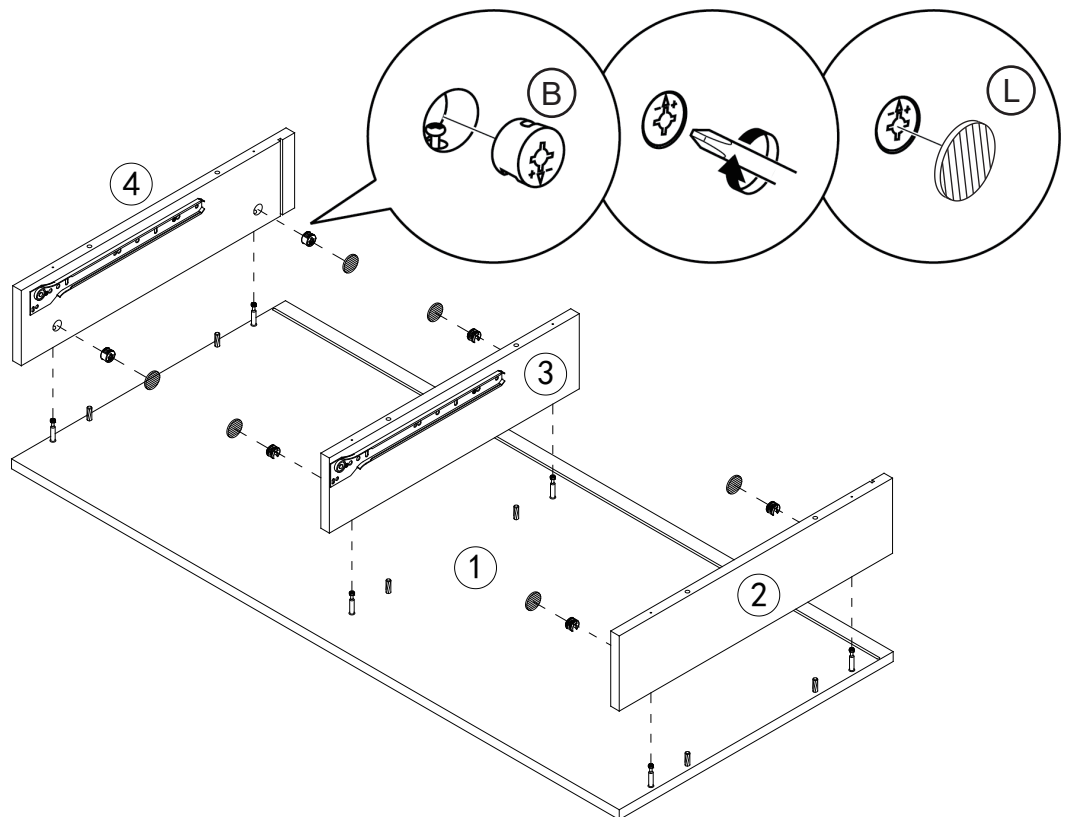

# 6

Slide the back panel (5) between the left and right panels (2, 4).

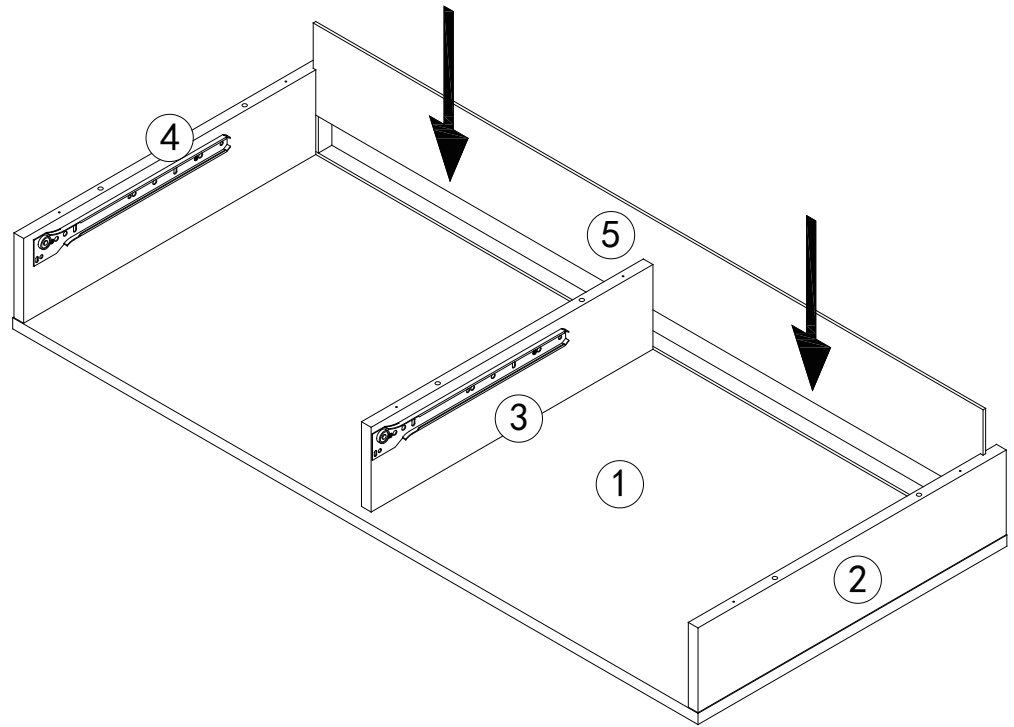

# 7

Insert wood dowels to the left panel (2), divider panel (3), and right panel (4).

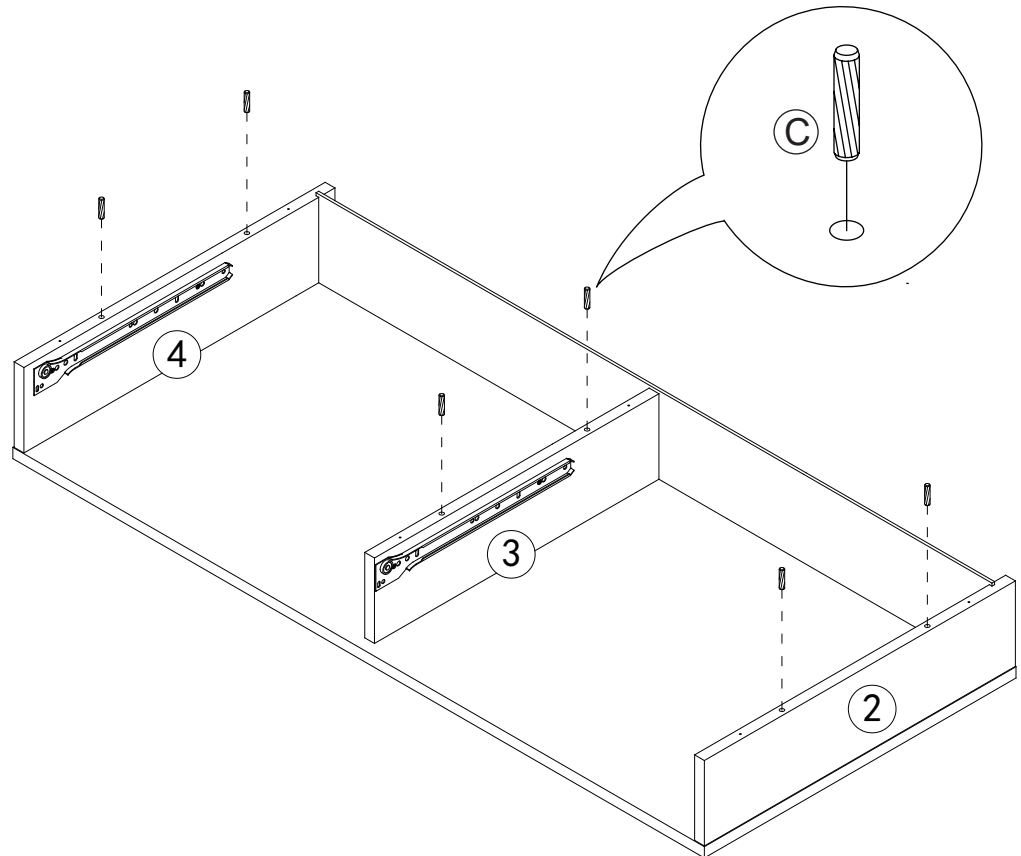

# 8

Assemble the bottom panel (6) to the table assembly.

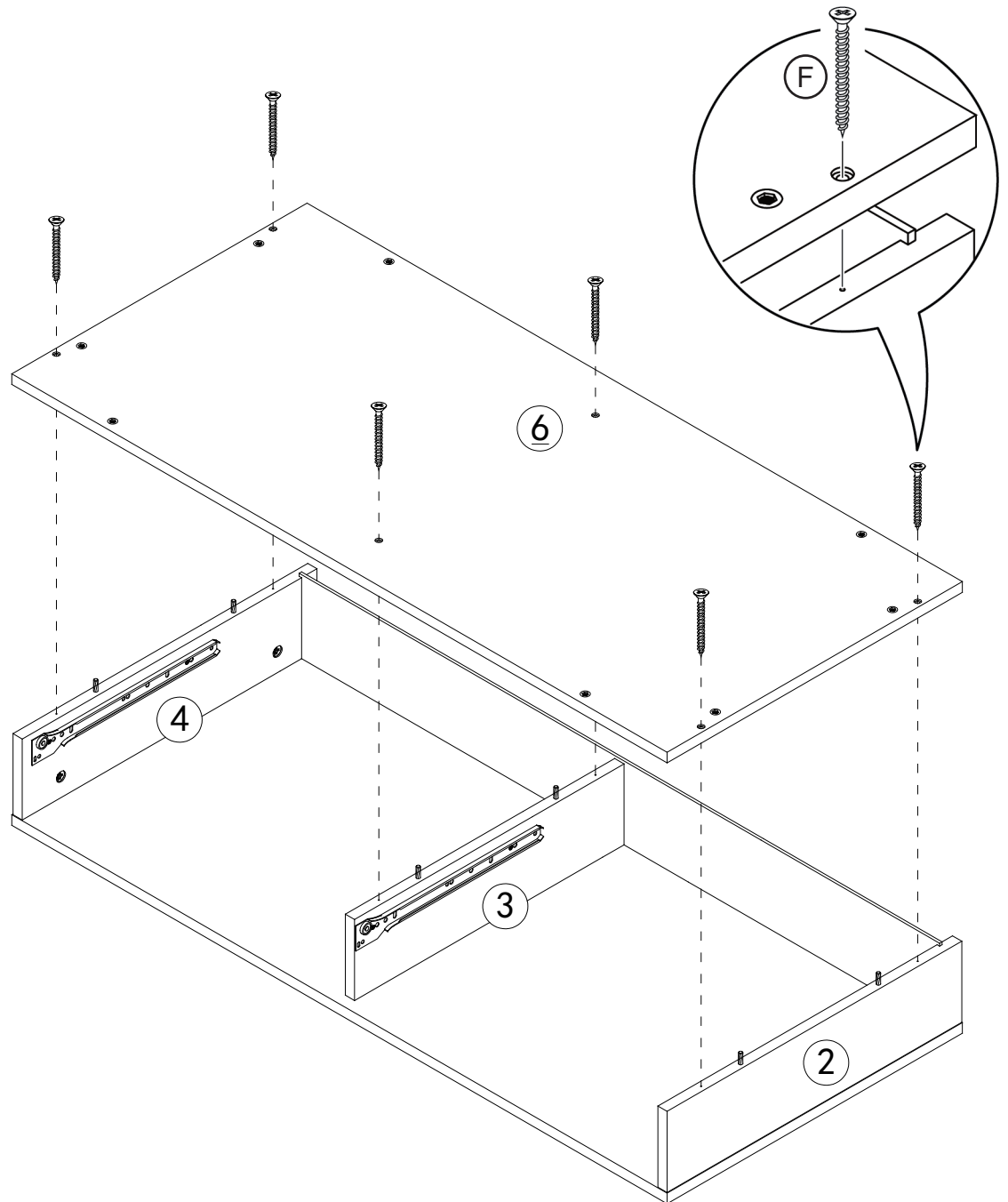

# 9

Assemble the crossbars (16) between the left and right frames (14, 15).

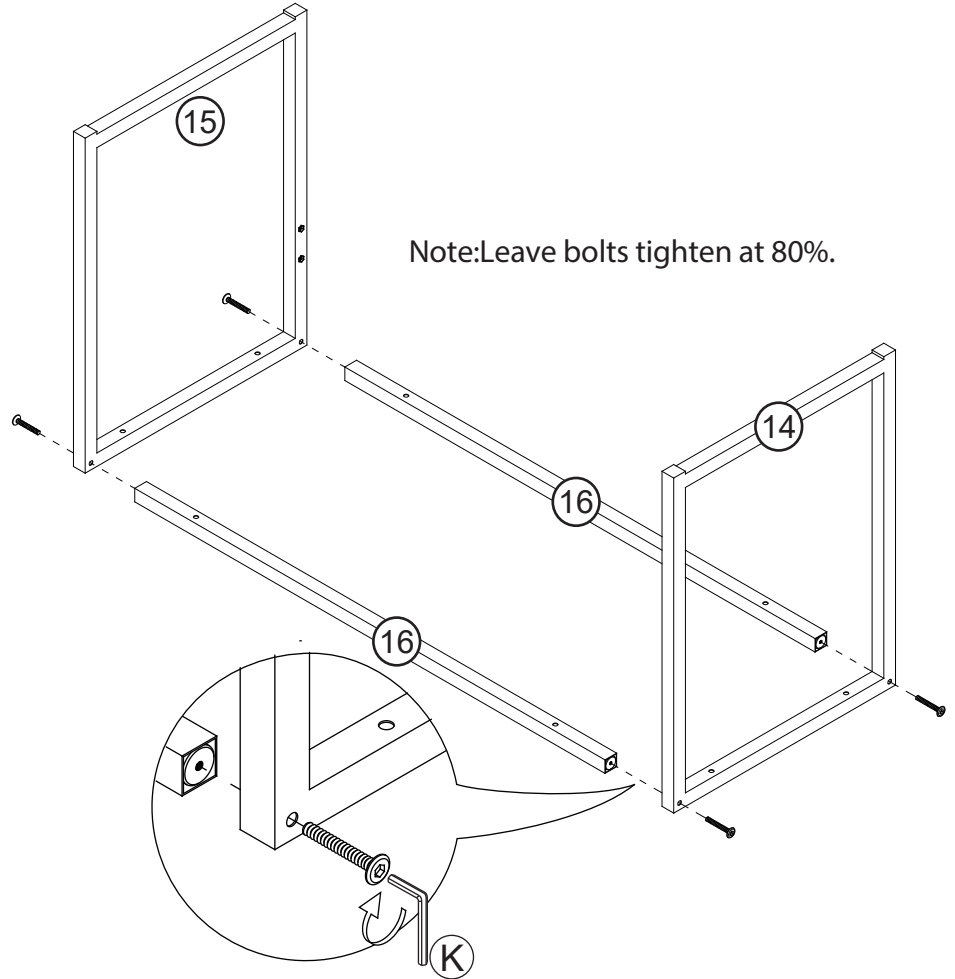
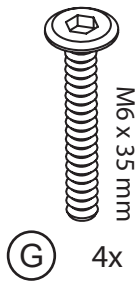

# 10

Assemble the center crossbar (17) between the left and right frames (14, 15).

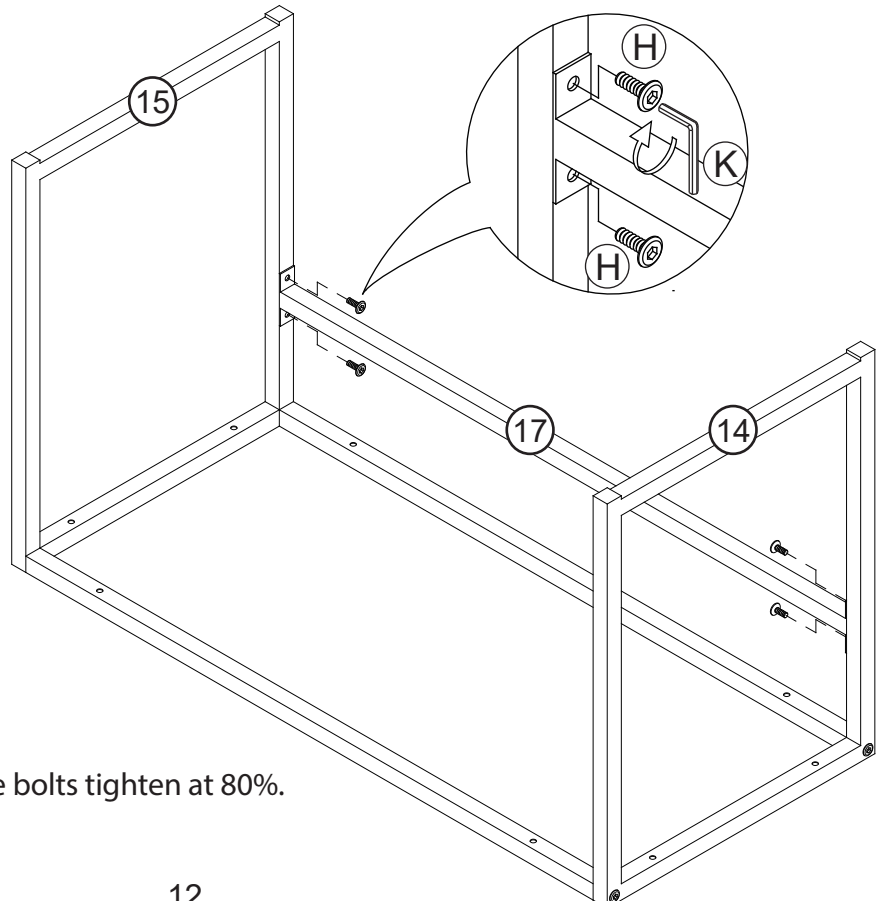
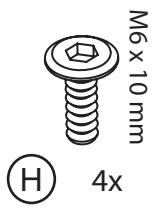

# 11

Assemble the frame assembly to the table assembly.

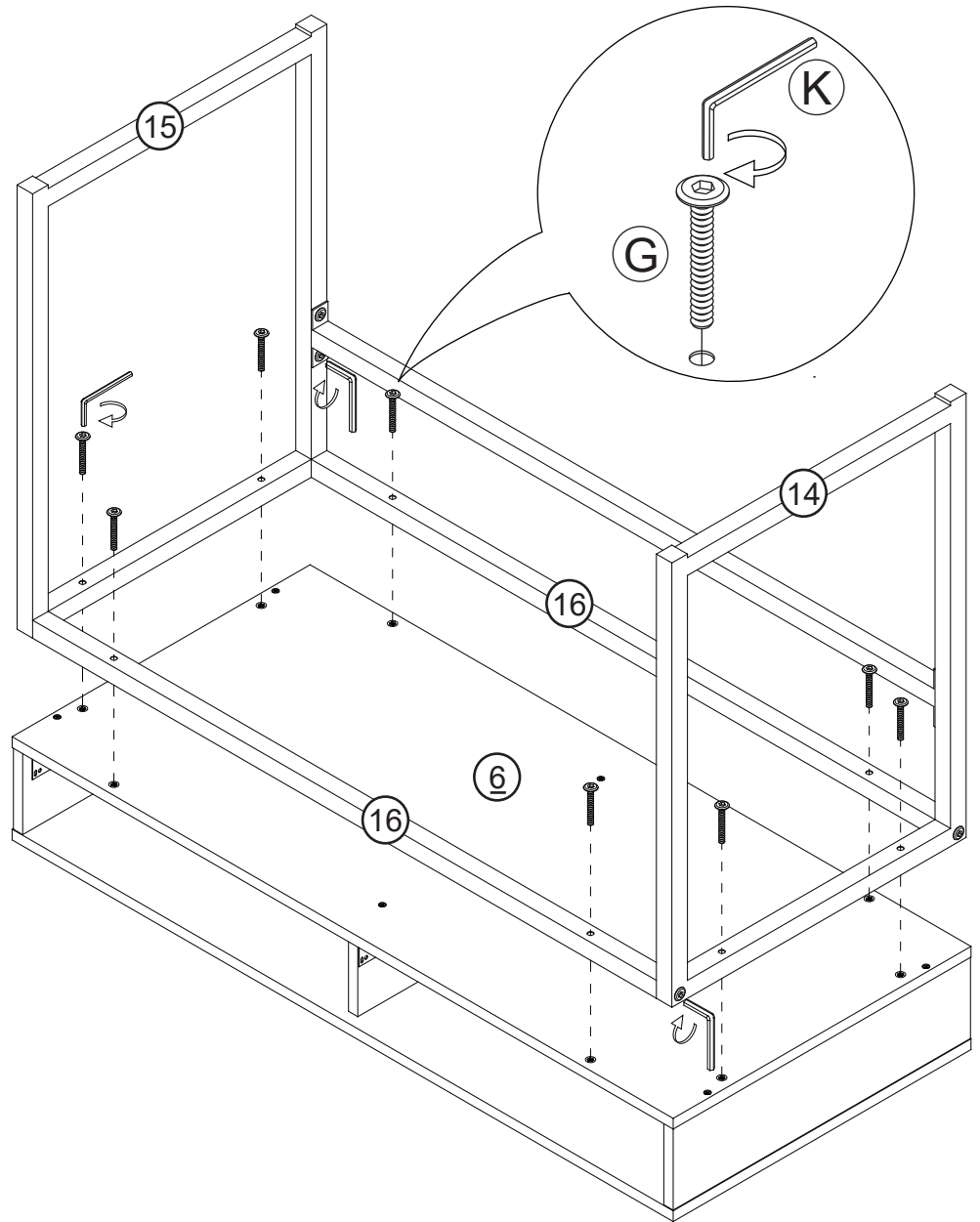

Note: Tighten all the bolts.

# 12

Assemble the drawer back panel (11) between the drawer left and right panels (7, 9), then assemble the drawer drawer strip (10) to the drawer back panel.



NOTE: Assemble 2 drawers.

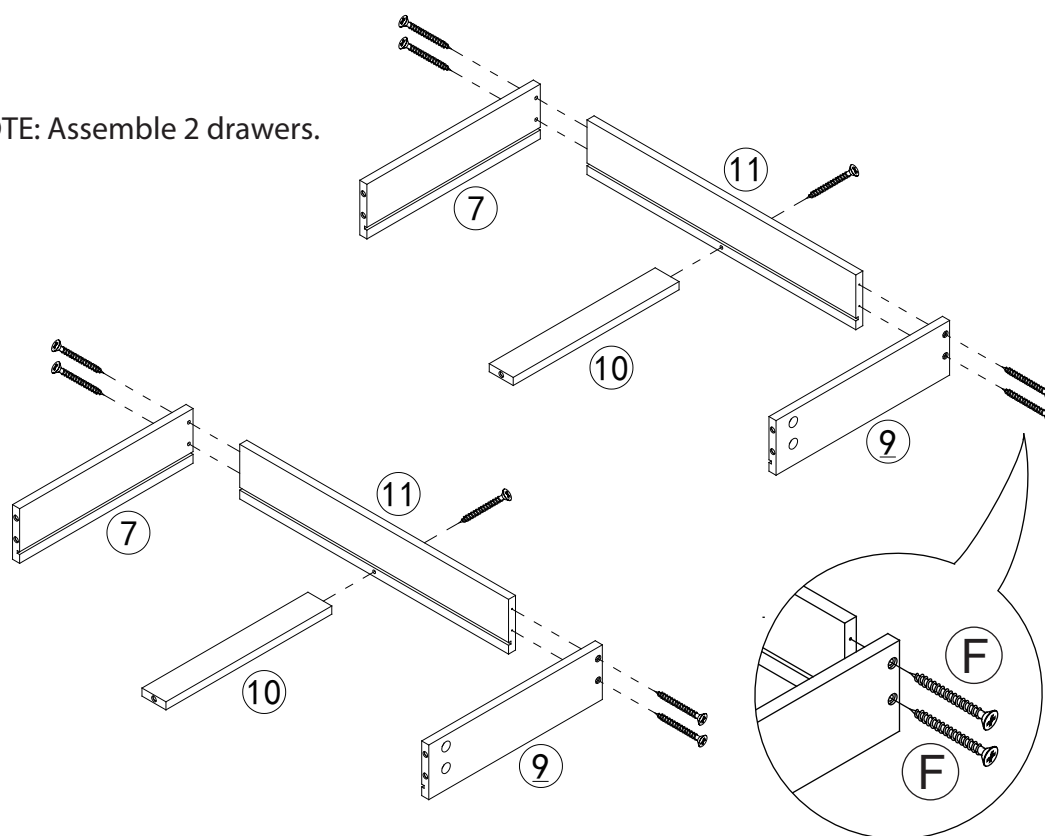

# 13

Slide drawer bottom panel (8) to the drawer assembly.

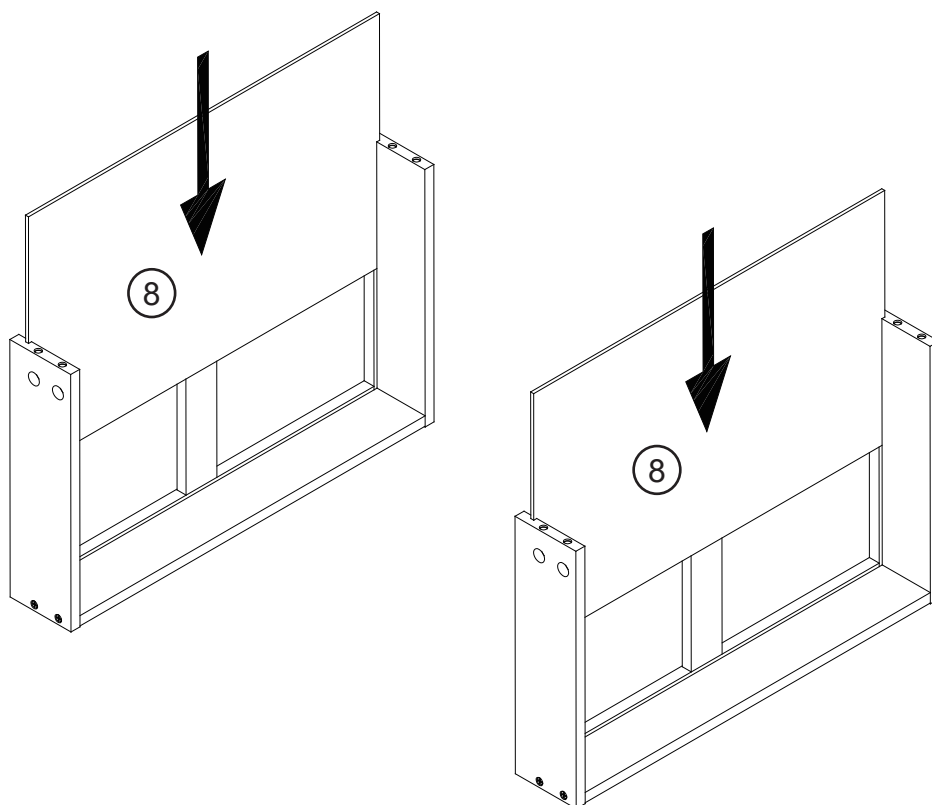

# 14

Attach cam bolts to the drawer front panels (12, 13).

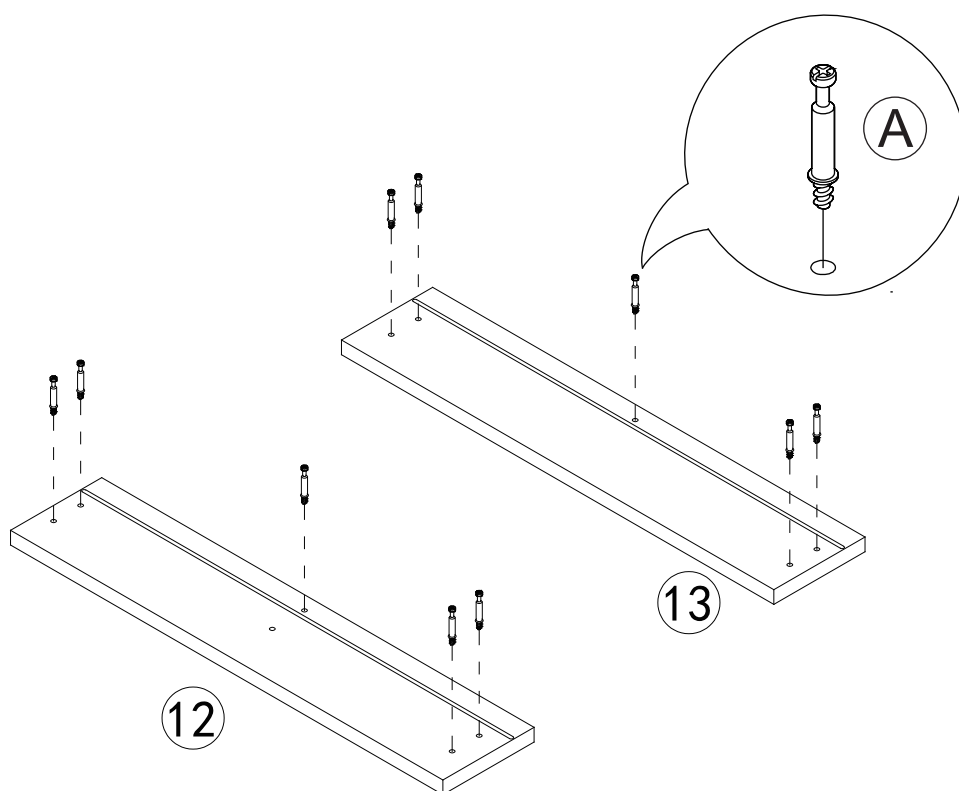
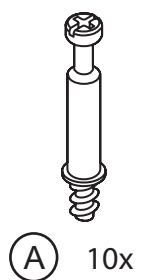

# 15

Attach drawer knobs to the drawer front panels (12, 13).

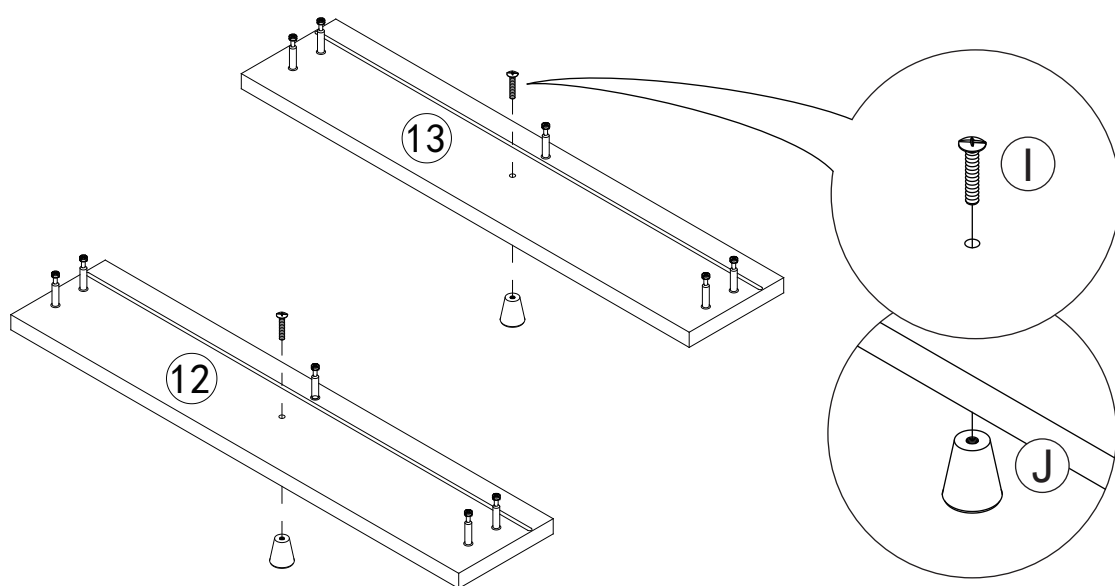
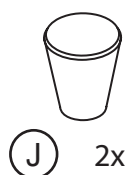

# 16

Assemble drawer front panels to the drawer trays.

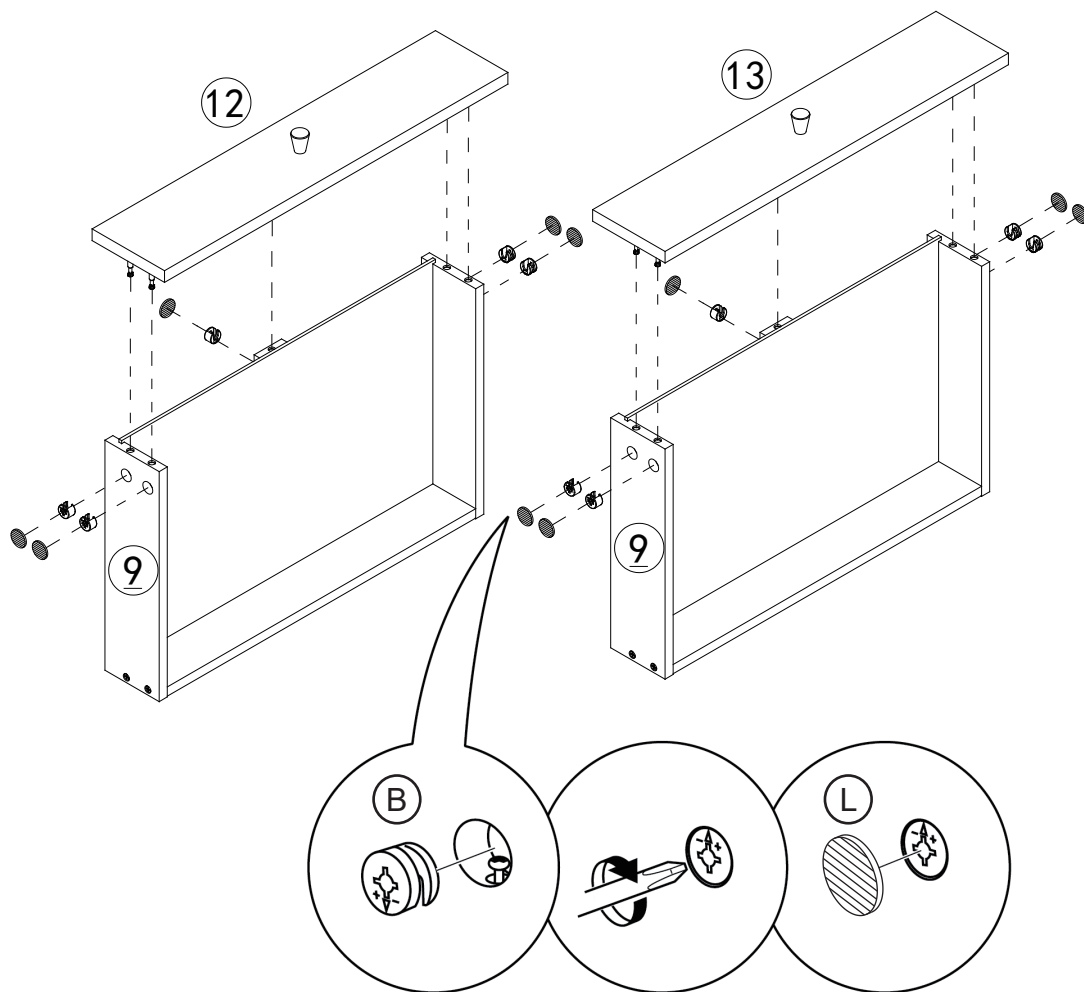
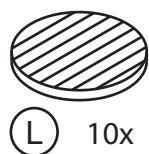

# 17

Attach drawer sliders under the drawers.

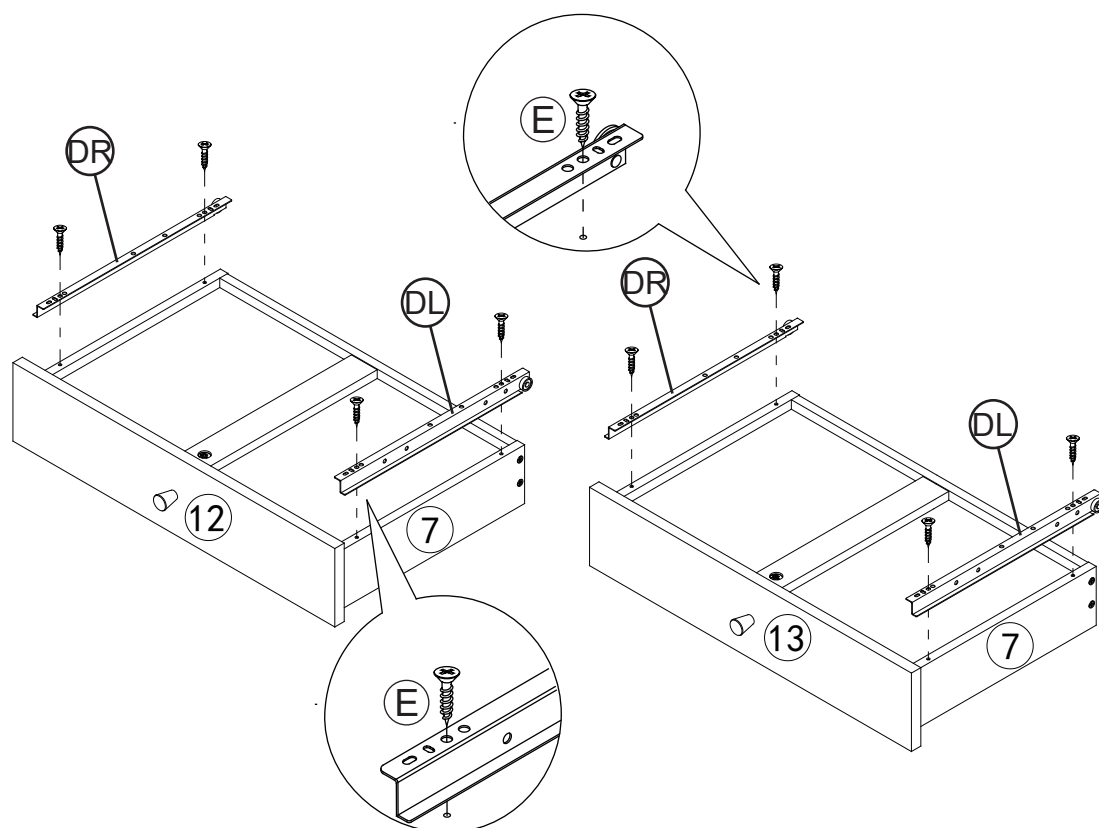
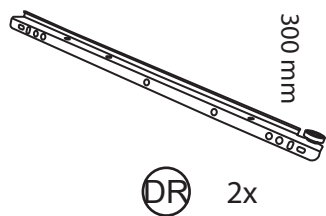
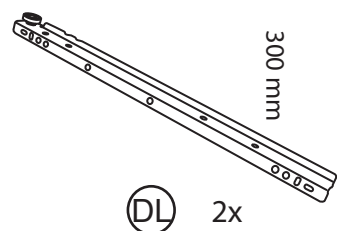

# 18

Slide drawers into the table.

There are differences between the left and right drawers. Please distinguish them when installing.

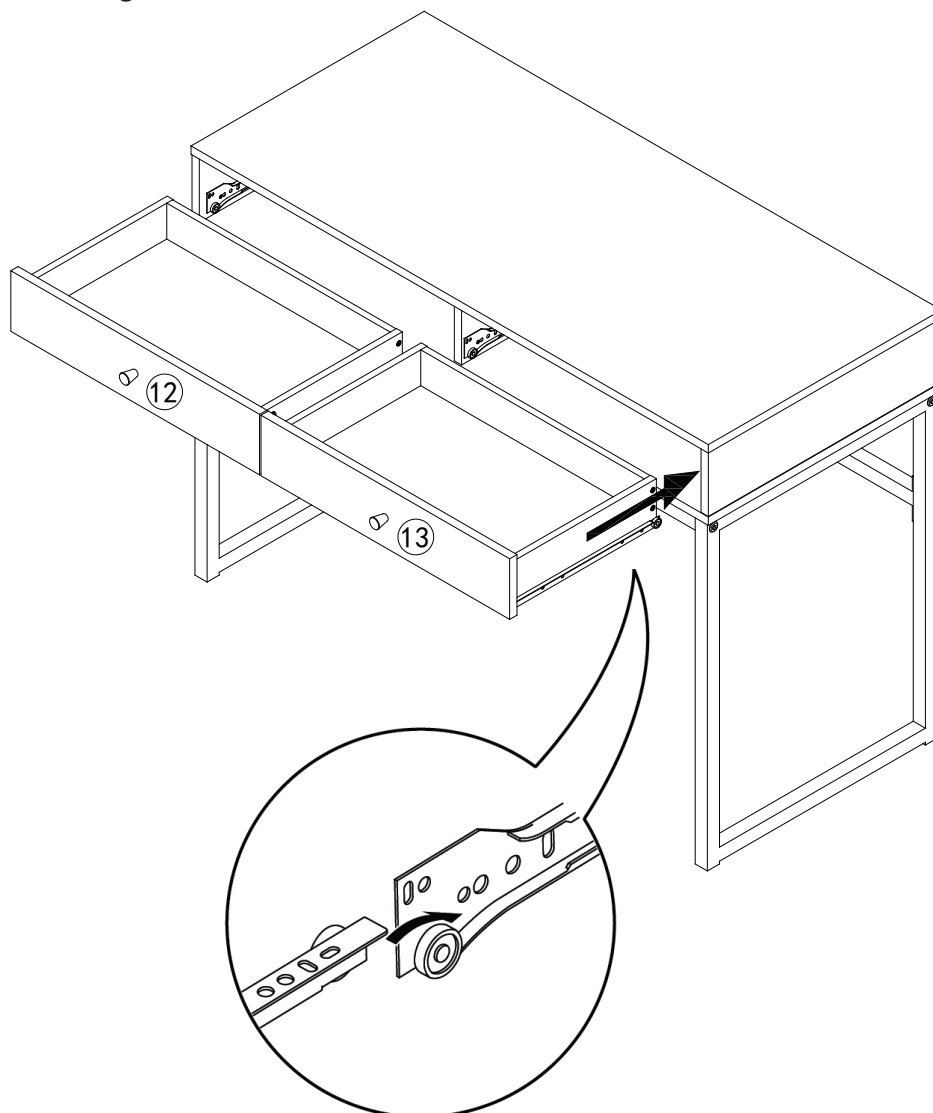



# 20

Attach table to a wall.

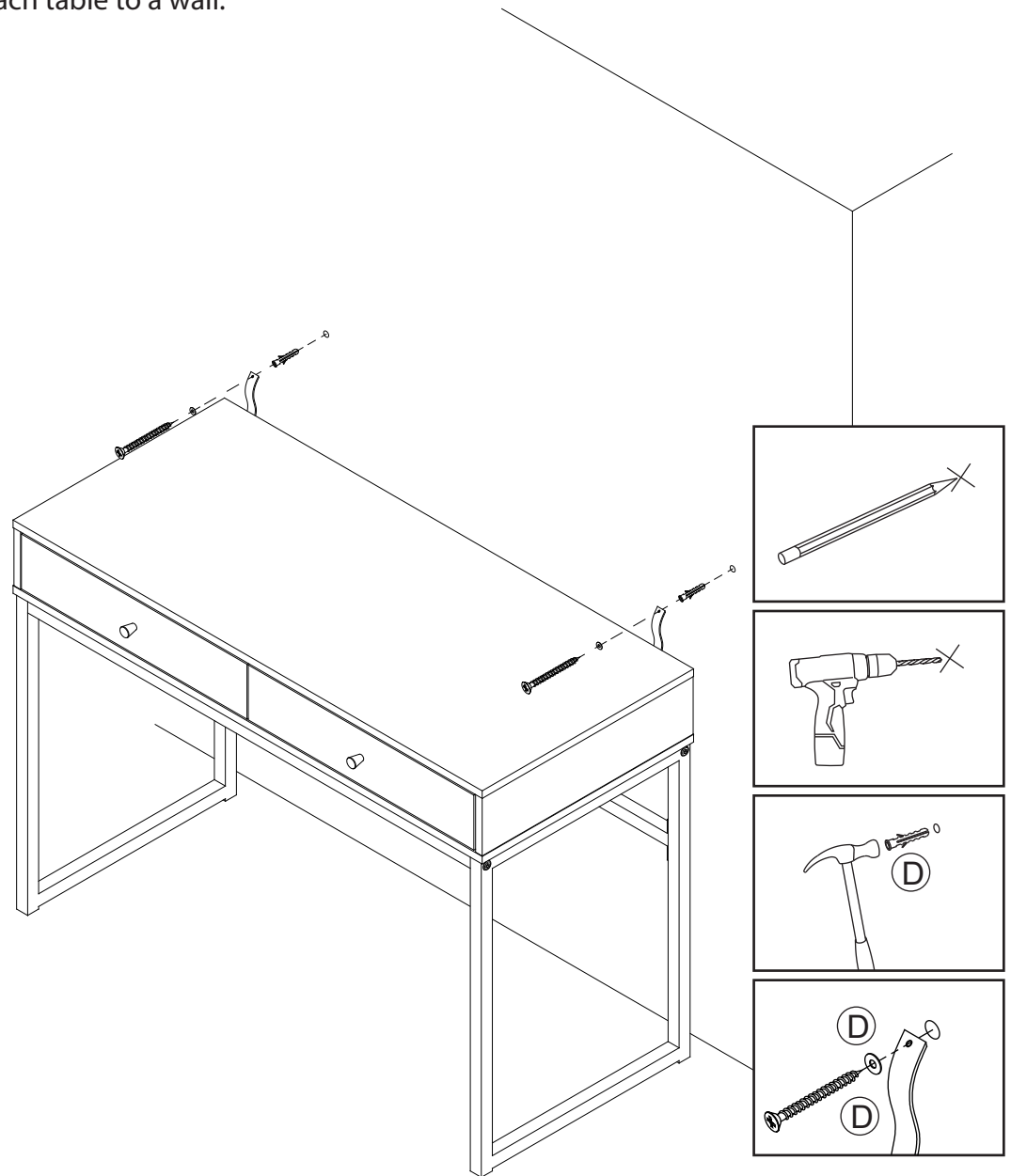
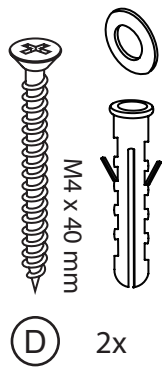

Furniture must permanently fixed to the wall stud with included anti-tipping device to prevent the furniture from tipping over.

- Mark drill positions on the wall with a pencil.
- Drill a small hole on the marked position.
- Insert wall anchors into the drilled holes.
- Zip tie the rack to the anti-tipping devices.

## YOU'RE FINISHED!

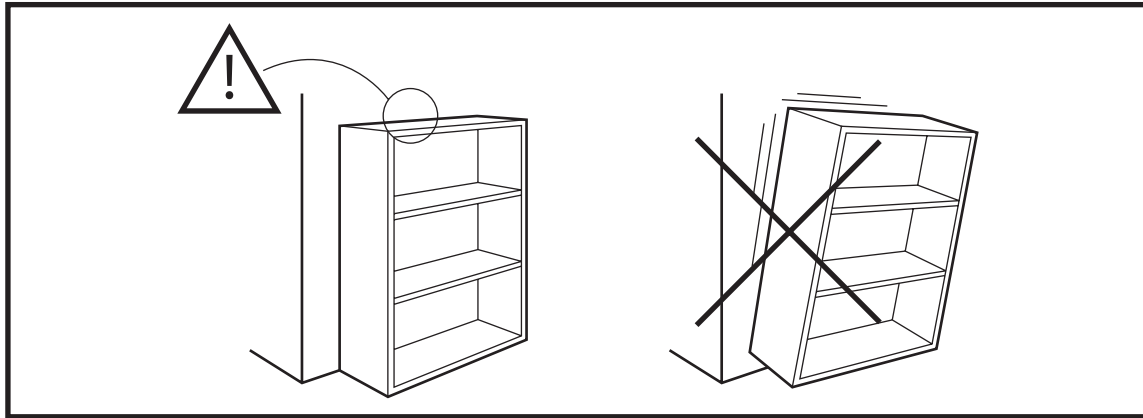

## Warning

Serious or fatal crushing injuries may occur if the furniture tip-over. Furniture must permanently affixed to the wall with included anti-tipping device in order to prevent the furniture from tipping over.

Different wall materials requires different types of wall anchors or screws. Use a suitable wall anchors or screws for your specific wall in order to secure the stability and load bearing capacity of the furniture. If you are uncertain about which type of device to use, please contact us or your local hardware store.

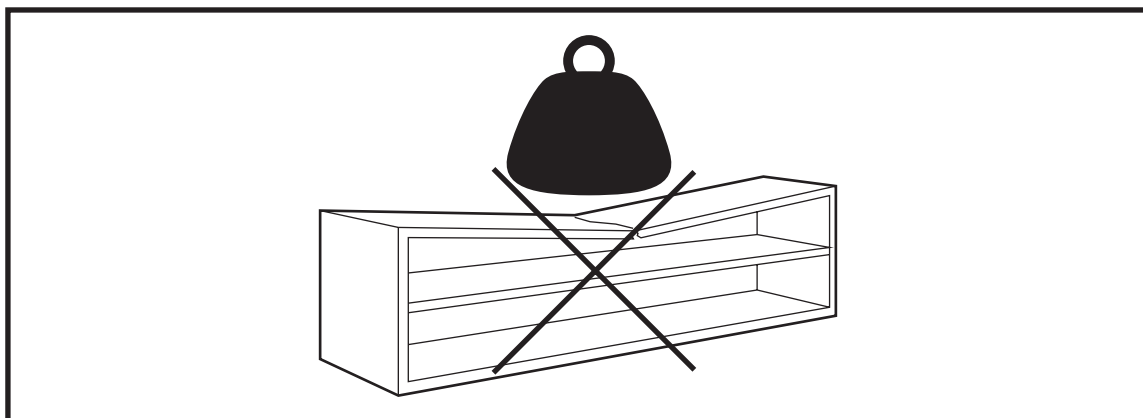

## Warning

Only place items on top of the product if they meet the recommended size and weight limits.

Climbing on, stepping on, or placing overweighted objects on the product may cause property damage and/or injuries.

Items placed onto this product must be resting on a support surface without hanging over the edges.

## FURNITURE CARE AND MAINTENANCE

### Medium - Density Fiberboard

Thank you for your purchase. We want your item to last as long as possible. To ensure the product gives you years of longevity, please follow the recommendations in this care and maintenance guide.



#### MAINTENANCE

- Tighten all bolts and screws again within the first 2 weeks of assembly.
- Check the tightness of all bolts every 2 months and tighten them if necessary.



#### CLEANING

- Clean the surface of the MDF (medium - density fiberboard) with a lightly dampened cloth.
- A small amount of mild soap can be used if necessary.
- Dry the surface immediately after cleaning.

⚠ DO NOT use bleach or alcohol to clean the surface.

⚠ DO NOT apply wood treatment on parts made with MDF.

MDF will swell and distort when exposed to water damage. Make sure to dry the furniture immediately after cleaning.

#### ⚠ WARNING

The manufacturer and seller are not responsible for any and all liability relating to personal injury, property damage or losses, whether direct, indirect, or incidental, resulting from the incorrect attachment, improper use, inadequate maintenance, unapproved modification or neglect of this product.

# WARRANTY

We products come with a 1-year warranty from the date of delivery. **Register your product on our website to enjoy our limited lifetime warranty!**

## AFTER-SALE SERVICE



Encounter any difficulties or missing parts?



Contact us



We will send you replacement.



Hassle free!  
No need to worry about repackaging and sending your item back.