

delivered in
2 separate boxes

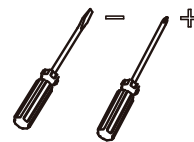

2 person



tools require



3 hours need





**PLEASE BE CAREFUL DO NOT DAMAGE THE HOLE POSITION
WHEN YOU USE POWER TOOLS !**

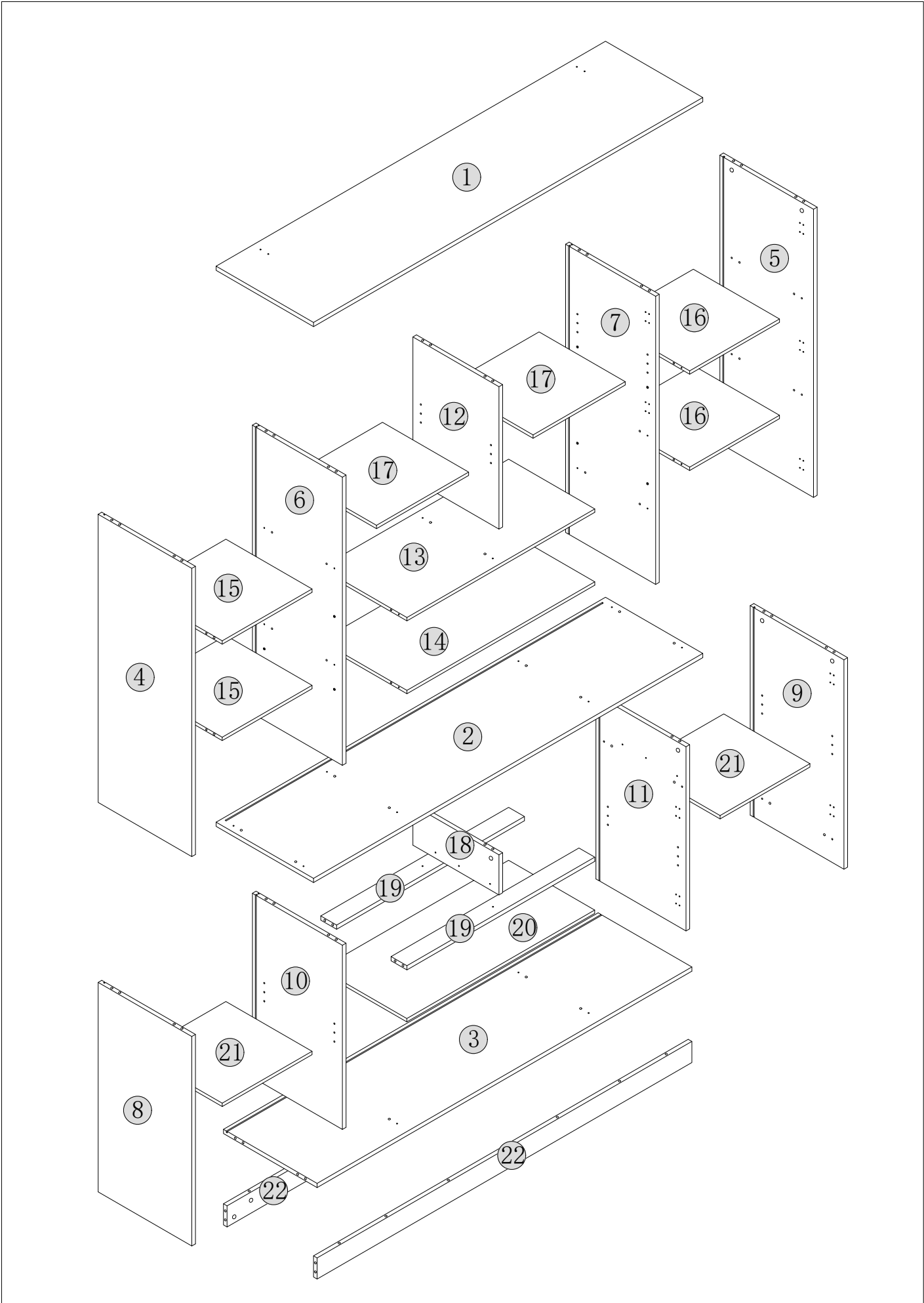

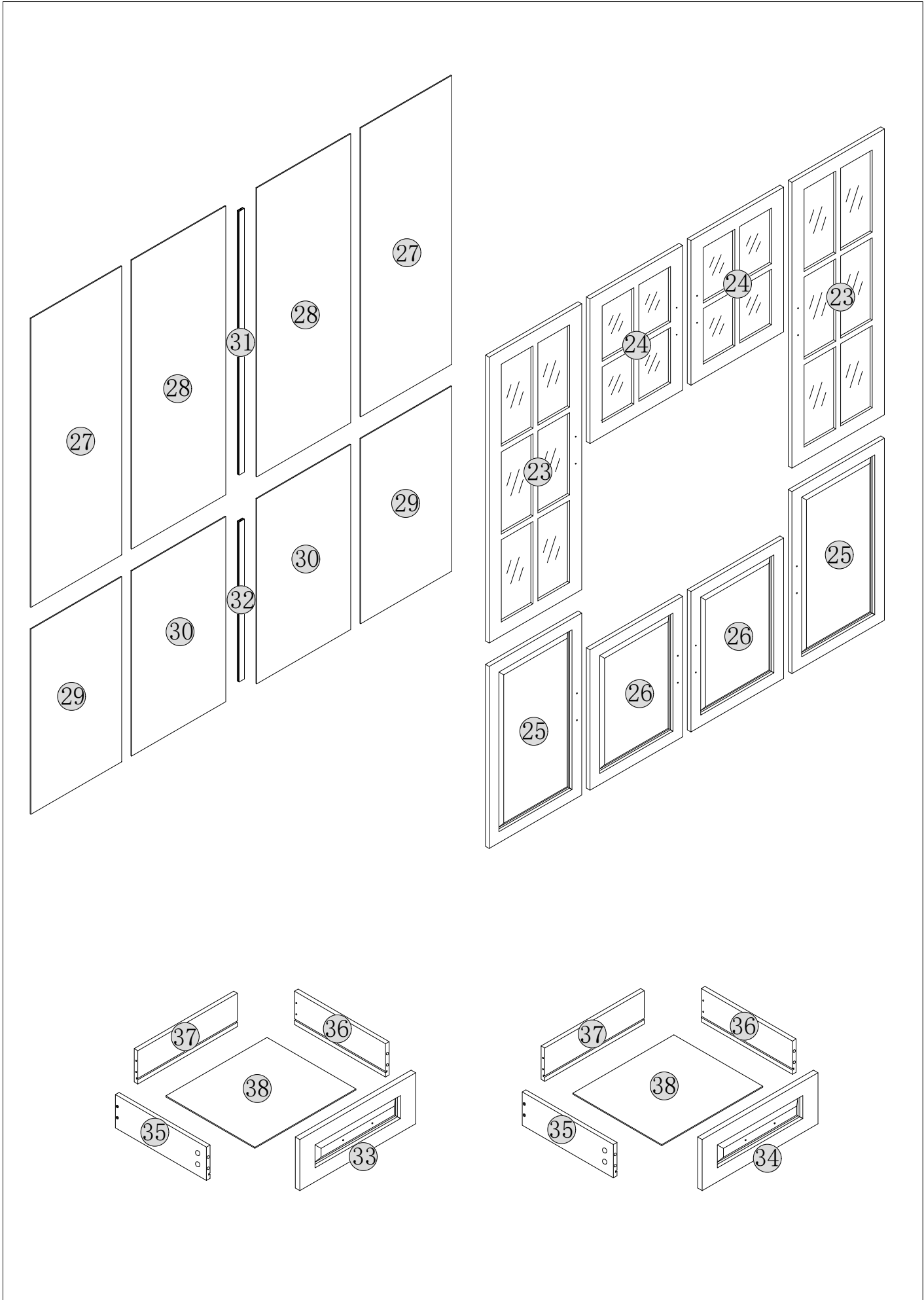

EXPLODED DRAWING

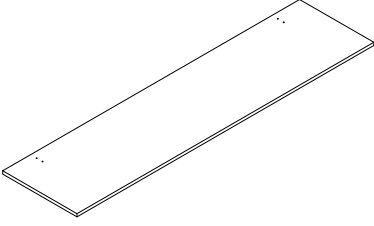
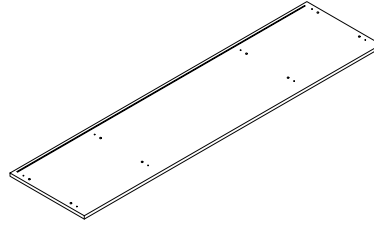
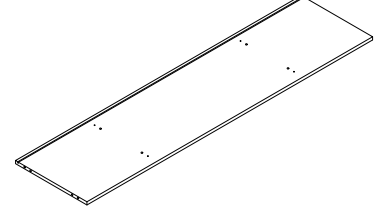
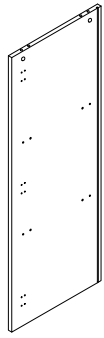

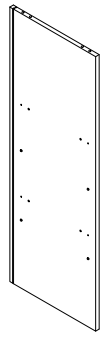
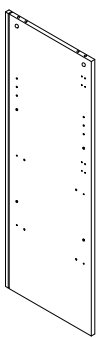
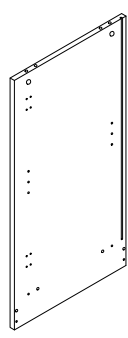
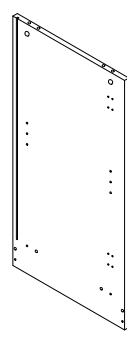
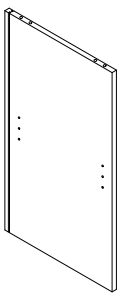
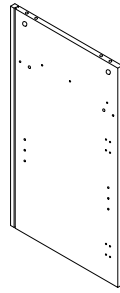
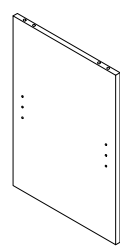
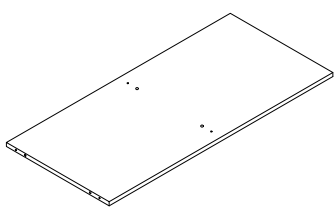
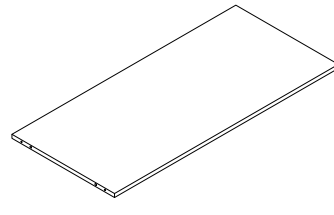
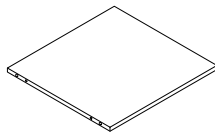

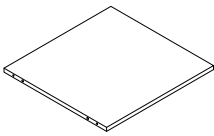
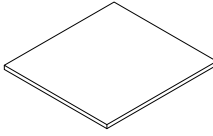
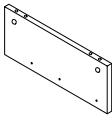
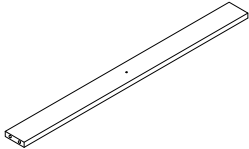
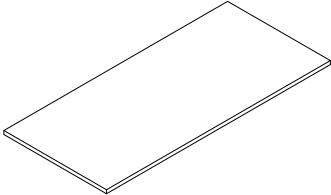
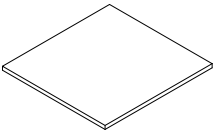
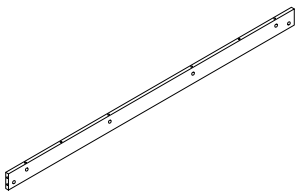
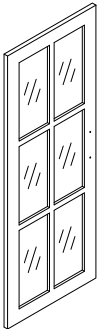
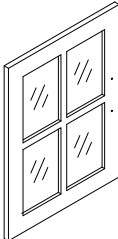
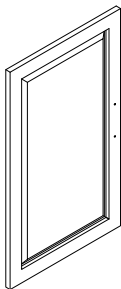
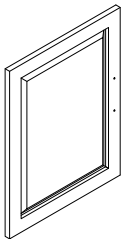

PARTS

<p>①</p>  <p>1PC</p>	<p>②</p>  <p>1PC</p>	<p>③</p>  <p>1PC</p>
<p>④</p>  <p>1PC</p>	<p>⑤</p>  <p>1PC</p>	<p>⑥</p>  <p>1PC</p>
<p>⑦</p>  <p>1PC</p>	<p>⑧</p>  <p>1PC</p>	<p>⑨</p>  <p>1PC</p>
<p>⑩</p>  <p>1PC</p>	<p>⑪</p>  <p>1PC</p>	<p>⑫</p>  <p>1PC</p>
<p>⑬</p>  <p>1PC</p>	<p>⑭</p>  <p>1PC</p>	<p>⑮</p>  <p>2PCS</p>

<p>①⑥</p>  <p>2PCS</p>	<p>①⑦</p>  <p>2PCS</p>	<p>①⑧</p>  <p>1PC</p>
<p>①⑨</p>  <p>2PCS</p>	<p>②⑩</p>  <p>1PC</p>	<p>②①</p>  <p>1PC</p>
<p>②②</p>  <p>2PCS</p>	<p>②③</p>  <p>2PCS</p>	<p>②④</p>  <p>2PCS</p>
<p>②⑤</p>  <p>2PCS</p>	<p>②⑥</p>  <p>2PCS</p>	<p>②⑦</p>  <p>2PCS</p>
<p>②⑧</p>  <p>2PCS</p>	<p>②⑨</p>  <p>2PCS</p>	<p>③⑩</p>  <p>2PCS</p>

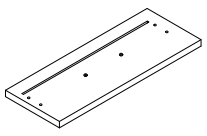
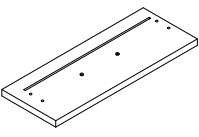
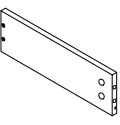
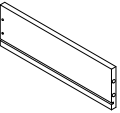
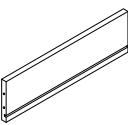
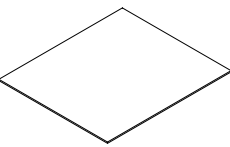
<p>③①</p>  <p>1PC</p>	<p>③②</p>  <p>1PC</p>	<p>③③</p>  <p>1PC</p>
<p>③④</p>  <p>1PC</p>	<p>③⑤</p>  <p>2PCS</p>	<p>③⑥</p>  <p>2PCS</p>
<p>③⑦</p>  <p>2PCS</p>	<p>③⑧</p>  <p>2PCS</p>	

Accessory List

A×2

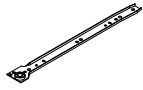

L 300mm

B×2

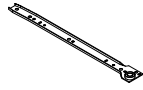

L 300mm

C×2

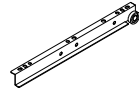

L 300mm

D×2

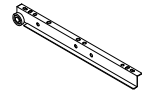

L 300mm

E×24



φ3×12mm

F×56



φ6×35mm

G×32



φ4×35mm

H×50



φ8×30mm

I×56



φ15×10mm

J×24



φ6×30mm

K×20



L×18



M×112



φ4×14mm

N×10



O×20



φ4×18mm

P×8



φ4×30mm

Q×30



R×30



φ3×14mm

S×2



T×2



U×2







φ4×40mm

V×16

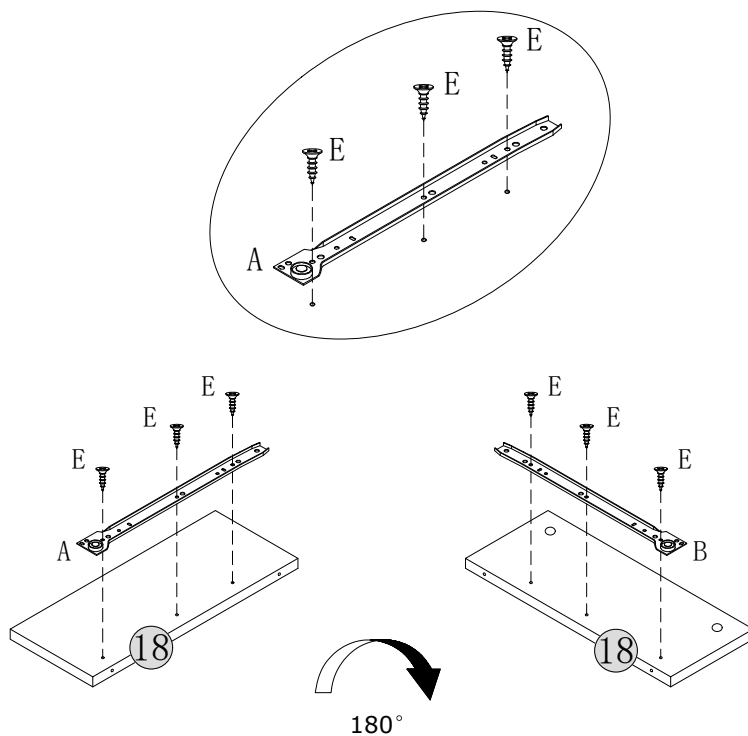





1

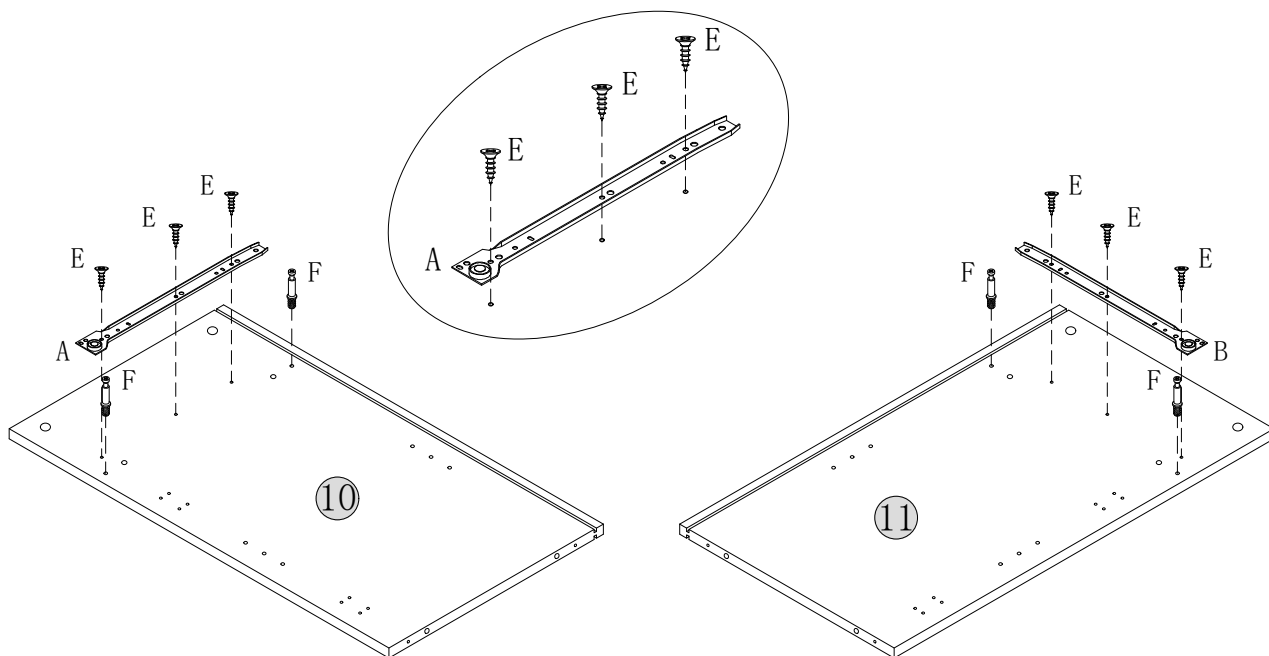

A × 1	B × 1	E × 6
		
L 300mm	L 300mm	∅3 × 12mm

2

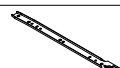

A × 1	B × 1	E × 6	F × 4
			
L 300mm	L 300mm	∅3 × 12mm	∅6 × 35mm

3

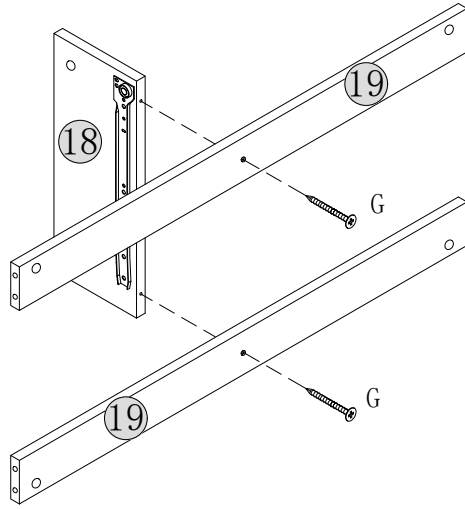

G × 2

Ø4 × 35mm

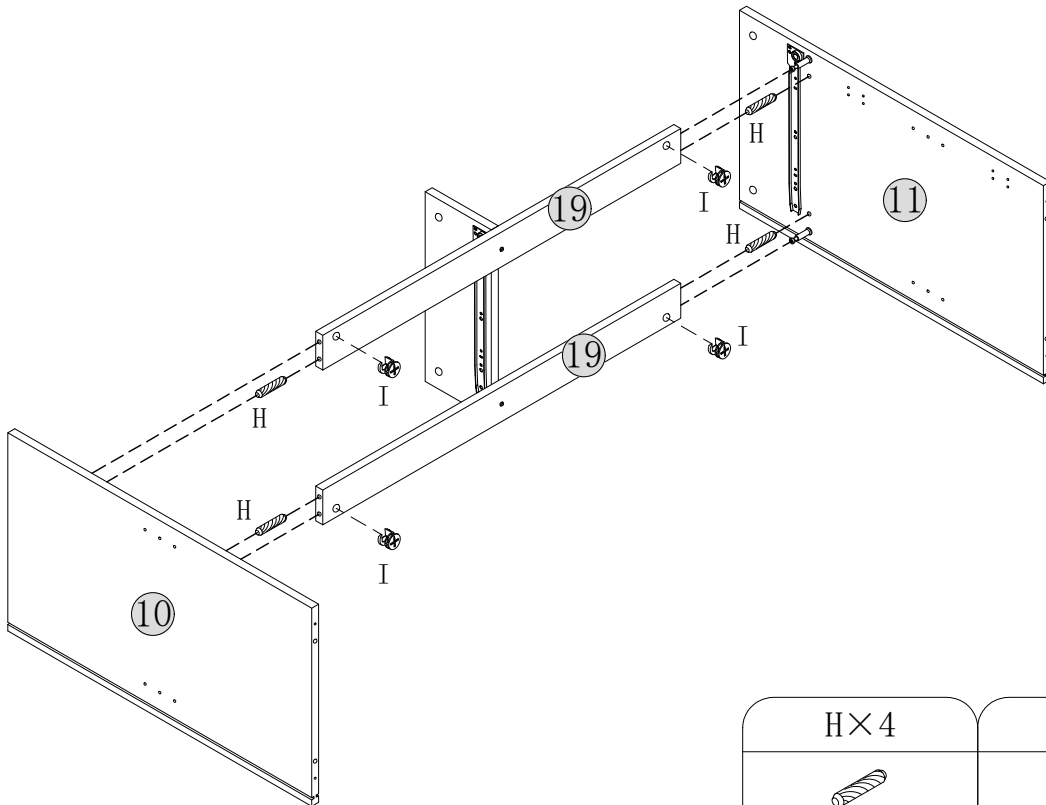
4



H × 4

Ø8 × 30mm

I × 4

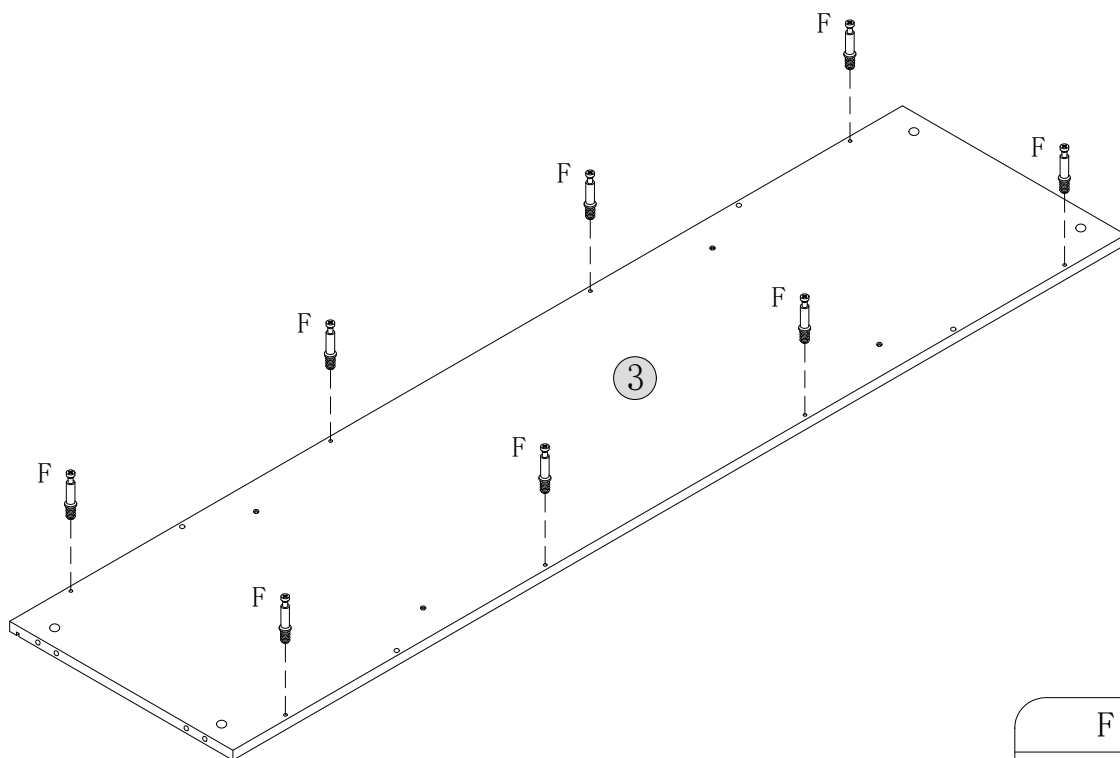
Ø15 × 10mm



5

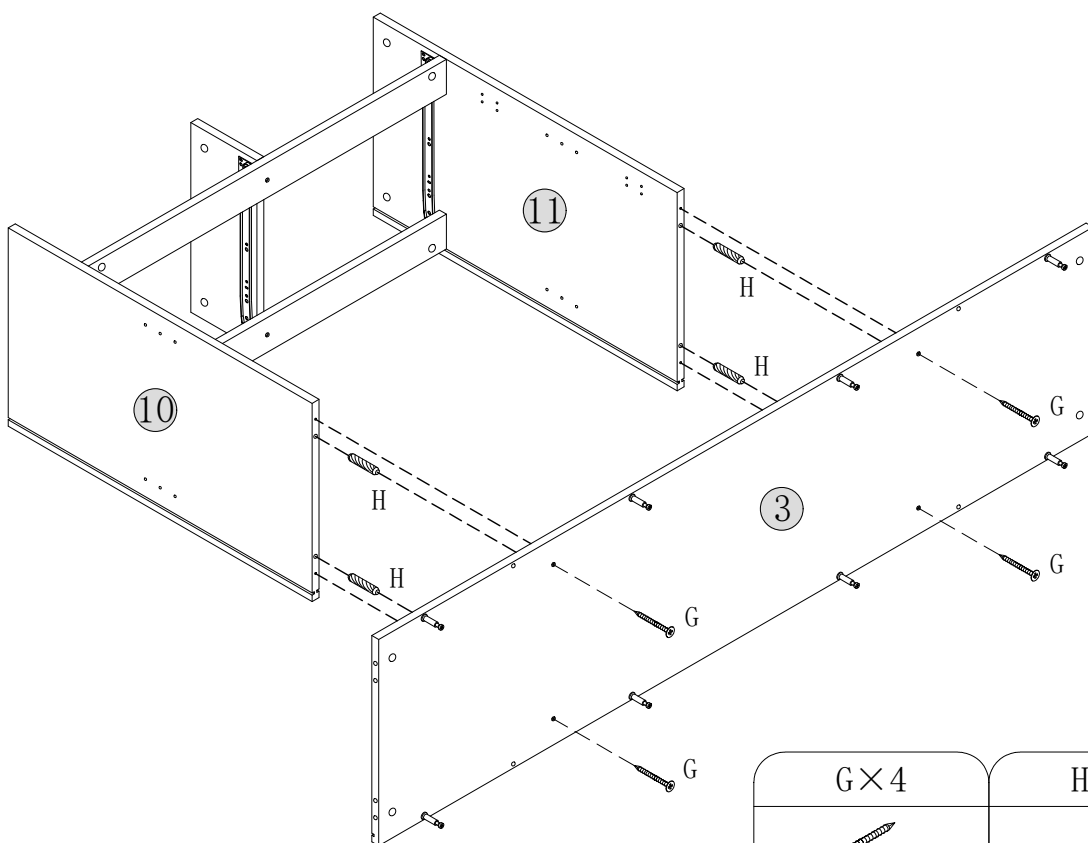

F × 8

Ø6 × 35mm

6

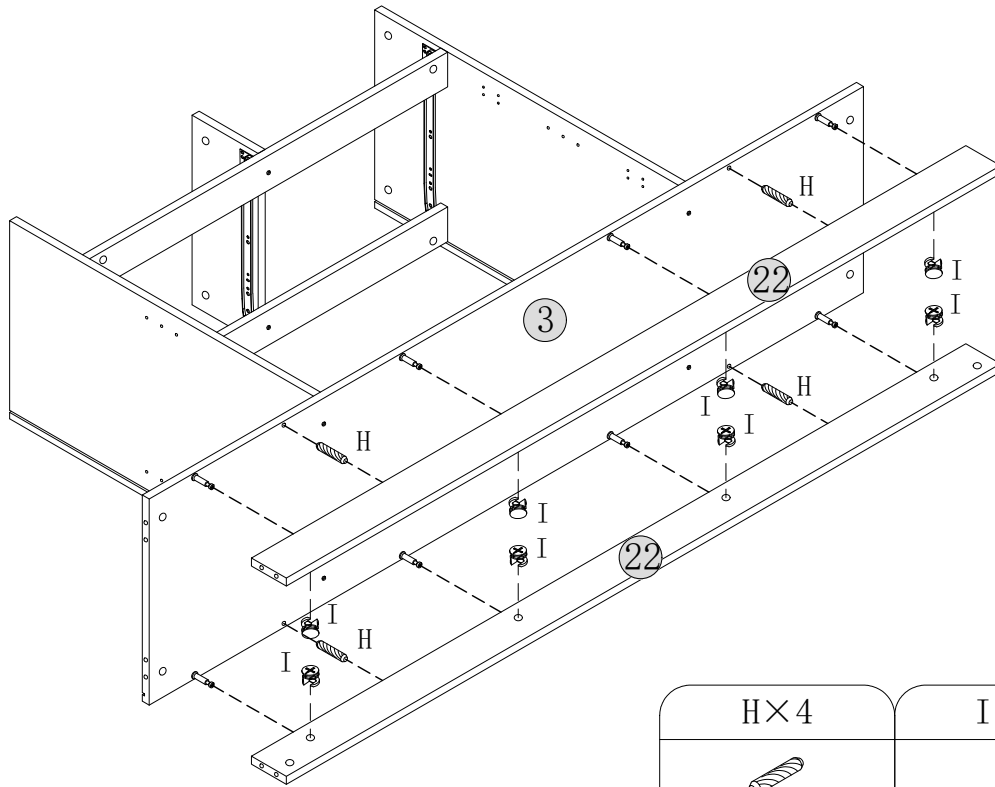

G × 4	H × 4
	
Ø4 × 35mm	Ø8 × 30mm

7



H×4

 $\phi 8 \times 30\text{mm}$

I×8

 $\phi 15 \times 10\text{mm}$

8

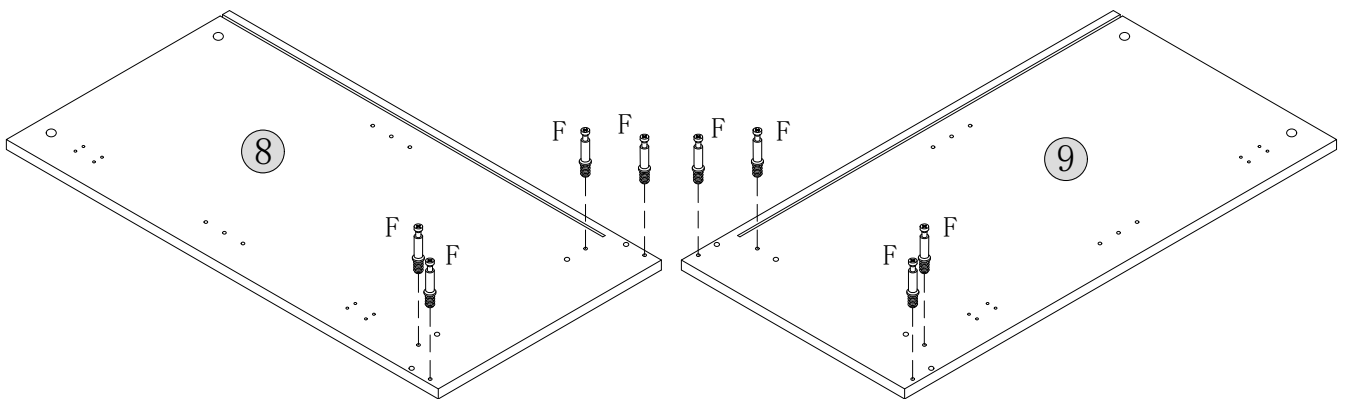



F×8

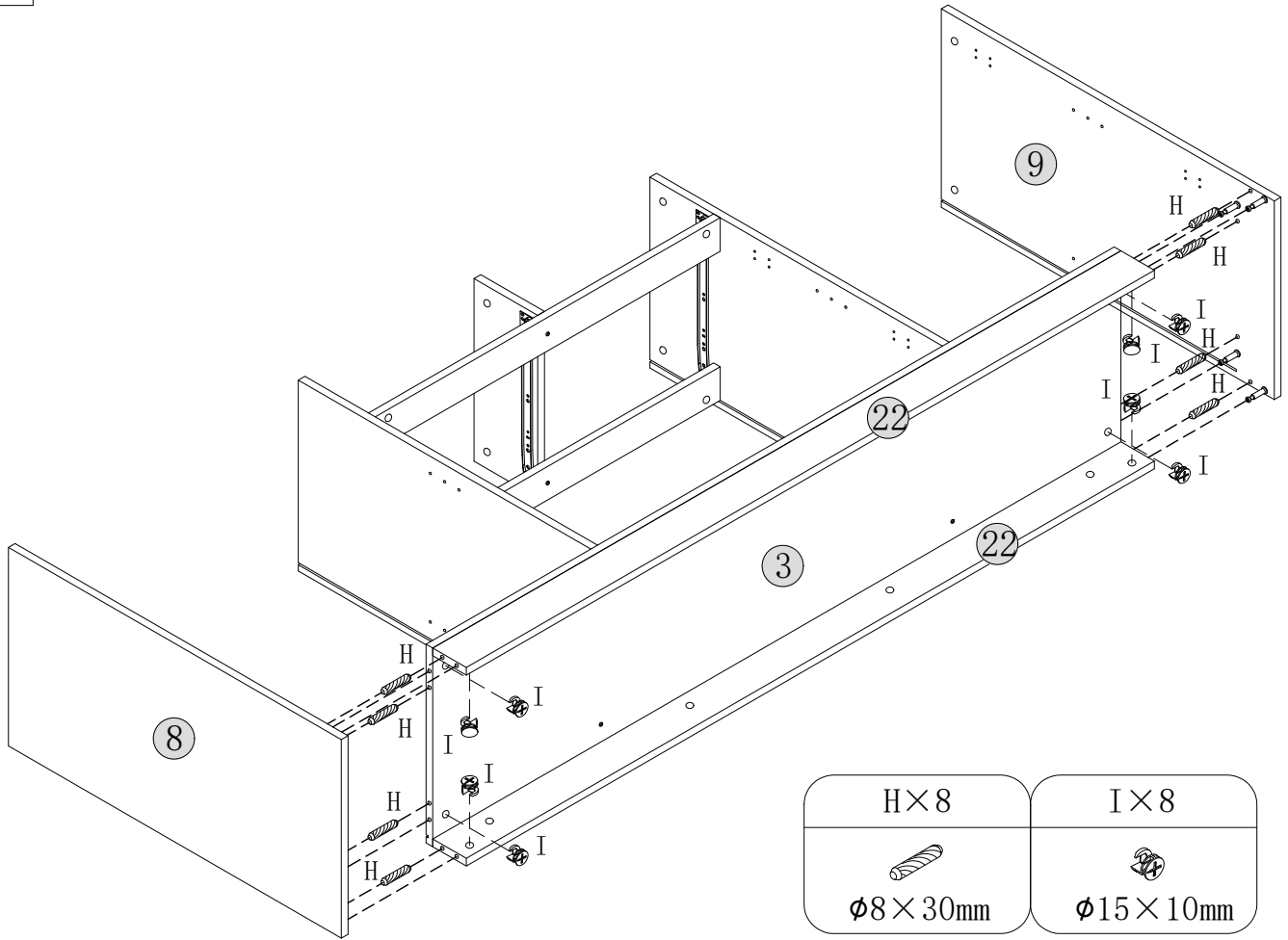

 $\phi 6 \times 35\text{mm}$



9

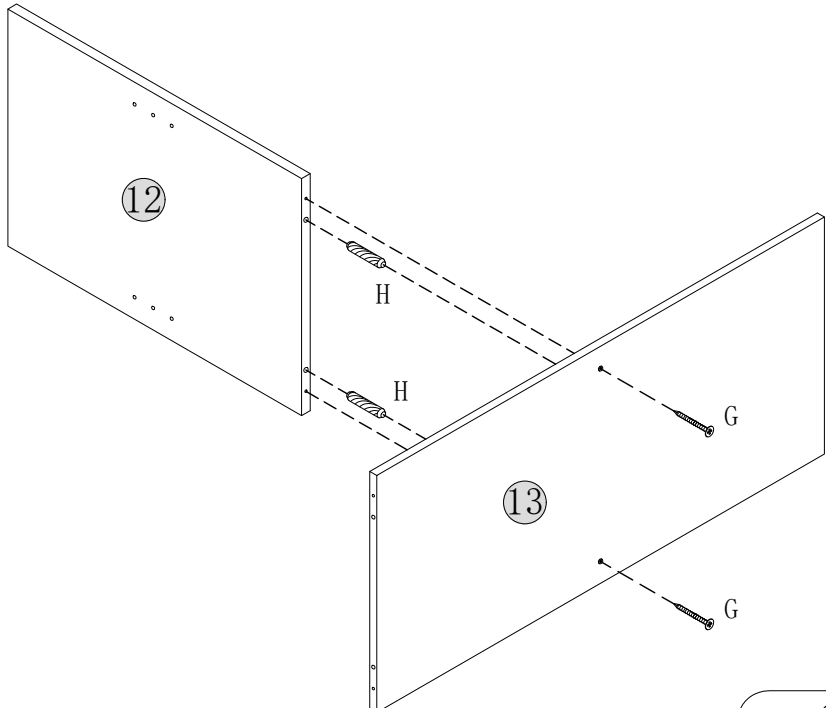

H × 8	I × 8
	
Ø8 × 30mm	Ø15 × 10mm



10

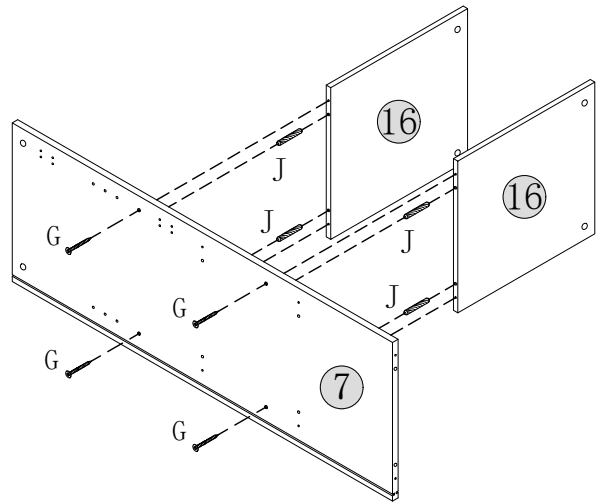
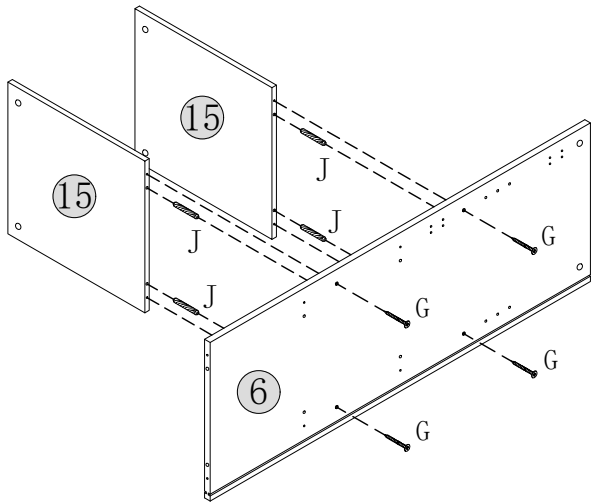

G × 2	H × 2
	
Ø4 × 35mm	Ø8 × 30mm

11



G × 8	J × 8
	
Ø4 × 35mm	Ø6 × 30mm

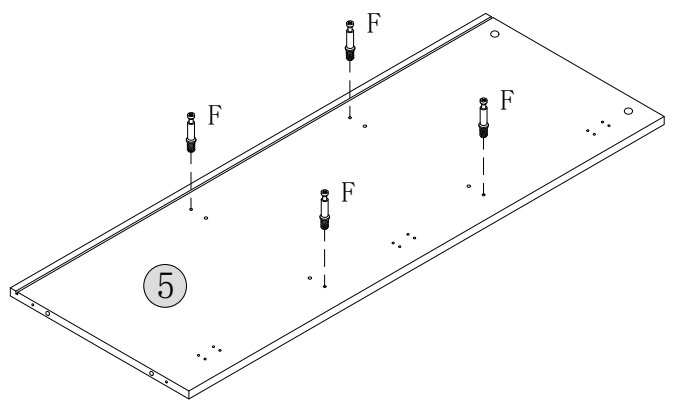
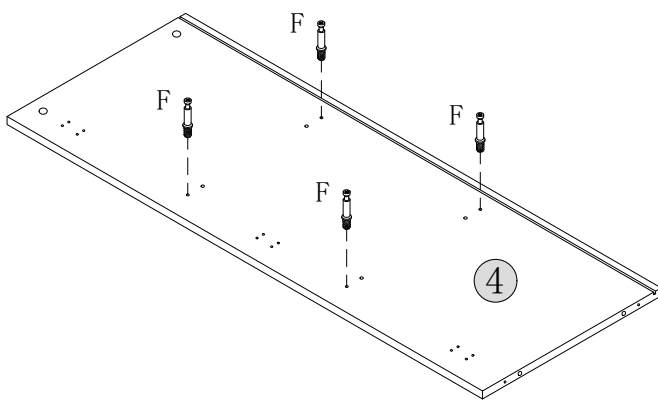

12

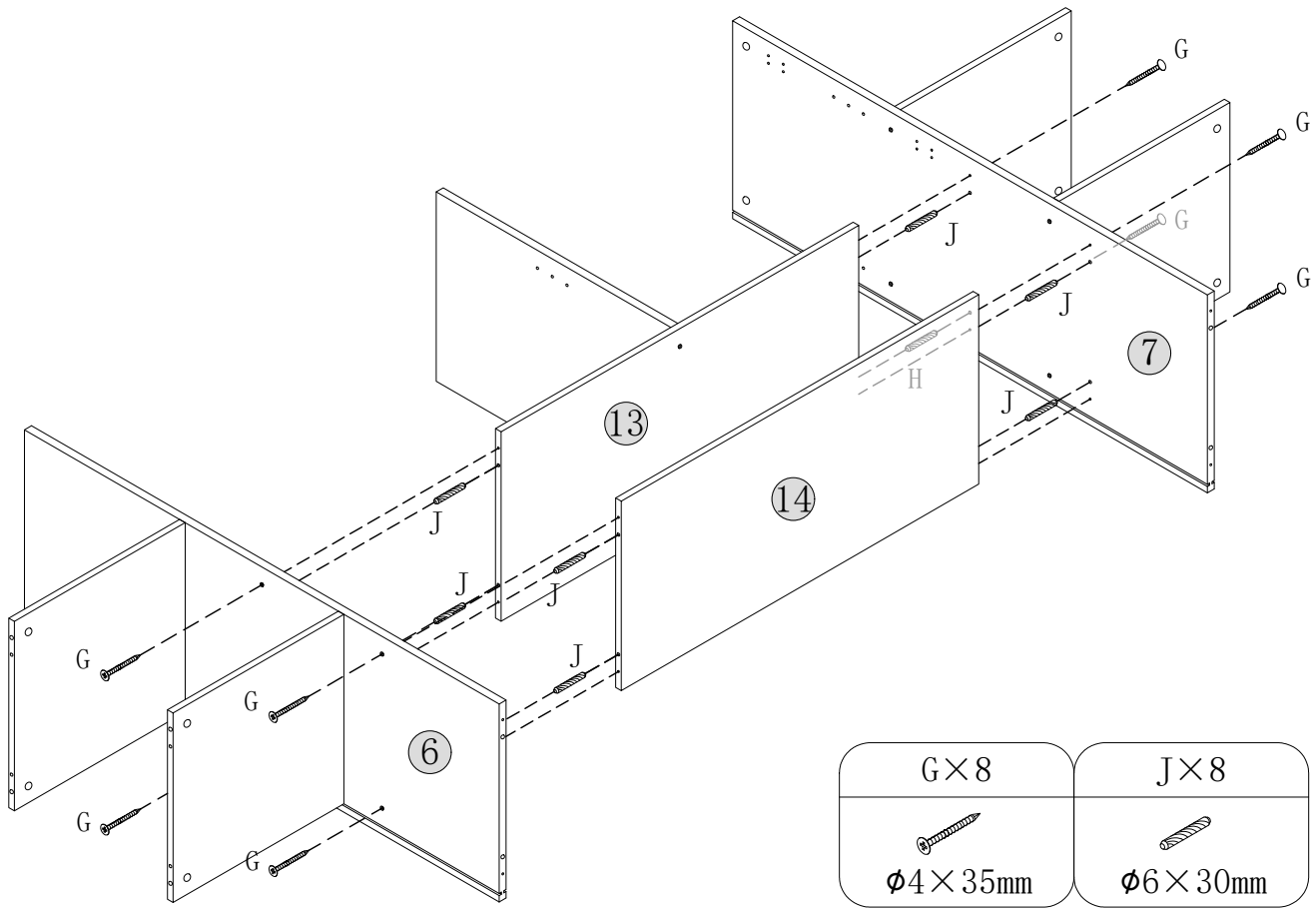

F × 8

Ø6 × 35mm



13

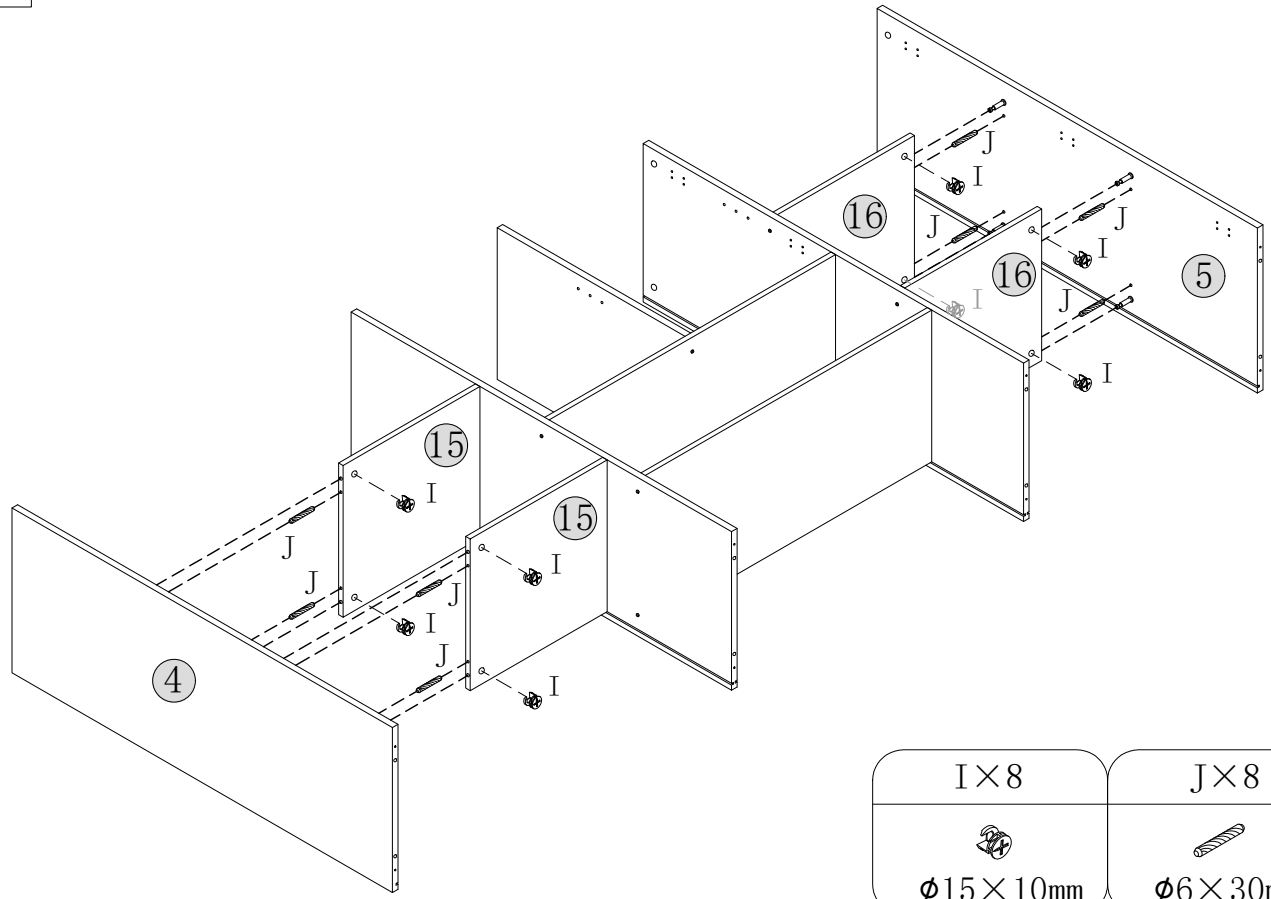

G × 8	J × 8
	
φ4 × 35mm	φ6 × 30mm

14



I × 8	J × 8
	
φ15 × 10mm	φ6 × 30mm

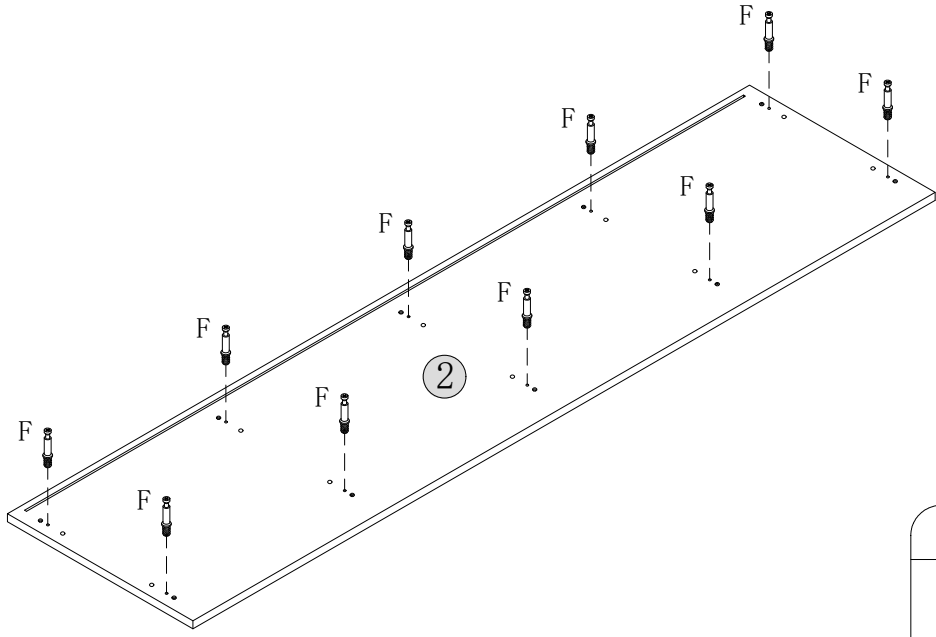

15

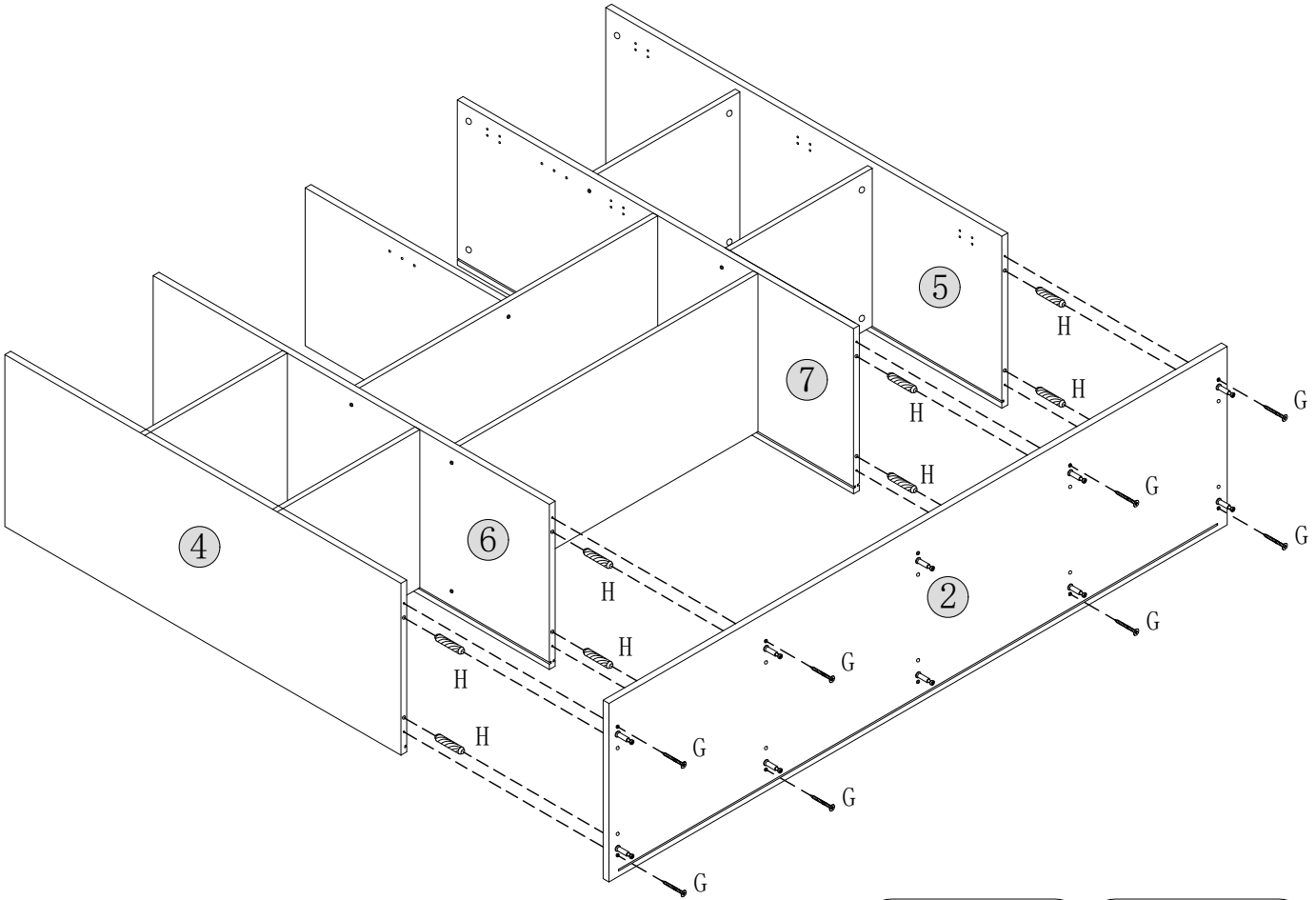

F × 10

∅6 × 35mm

16

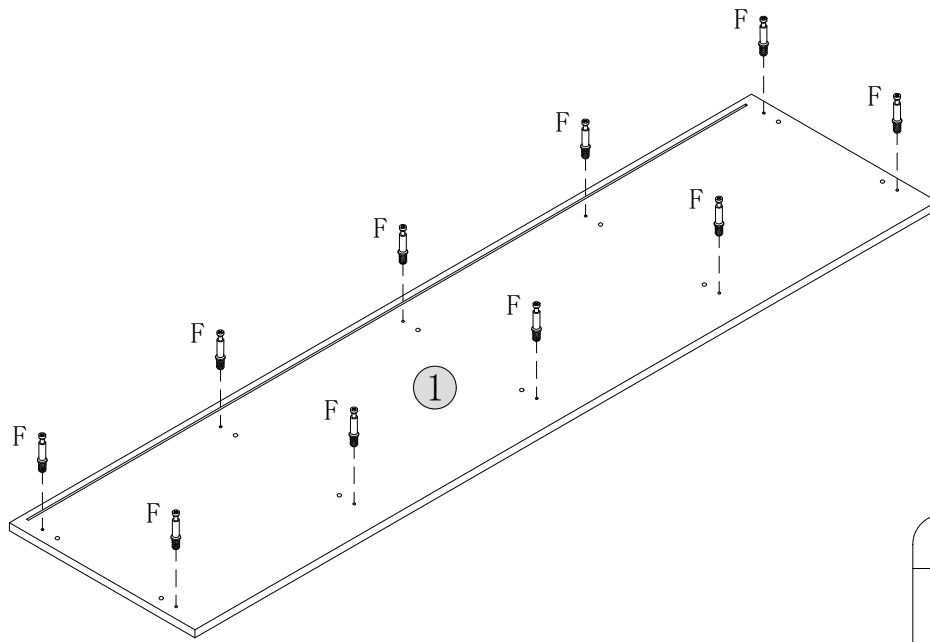

G × 8	H × 8
	
∅4 × 35mm	∅8 × 30mm

17



F x 10



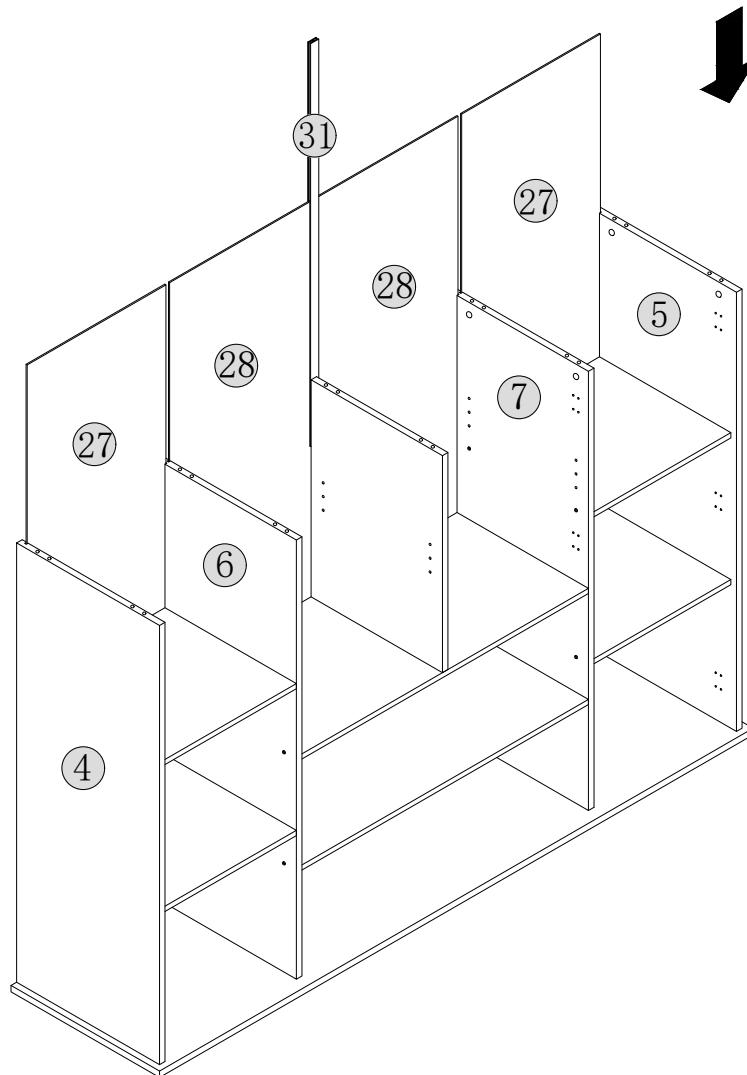

Ø6 x 35mm

18

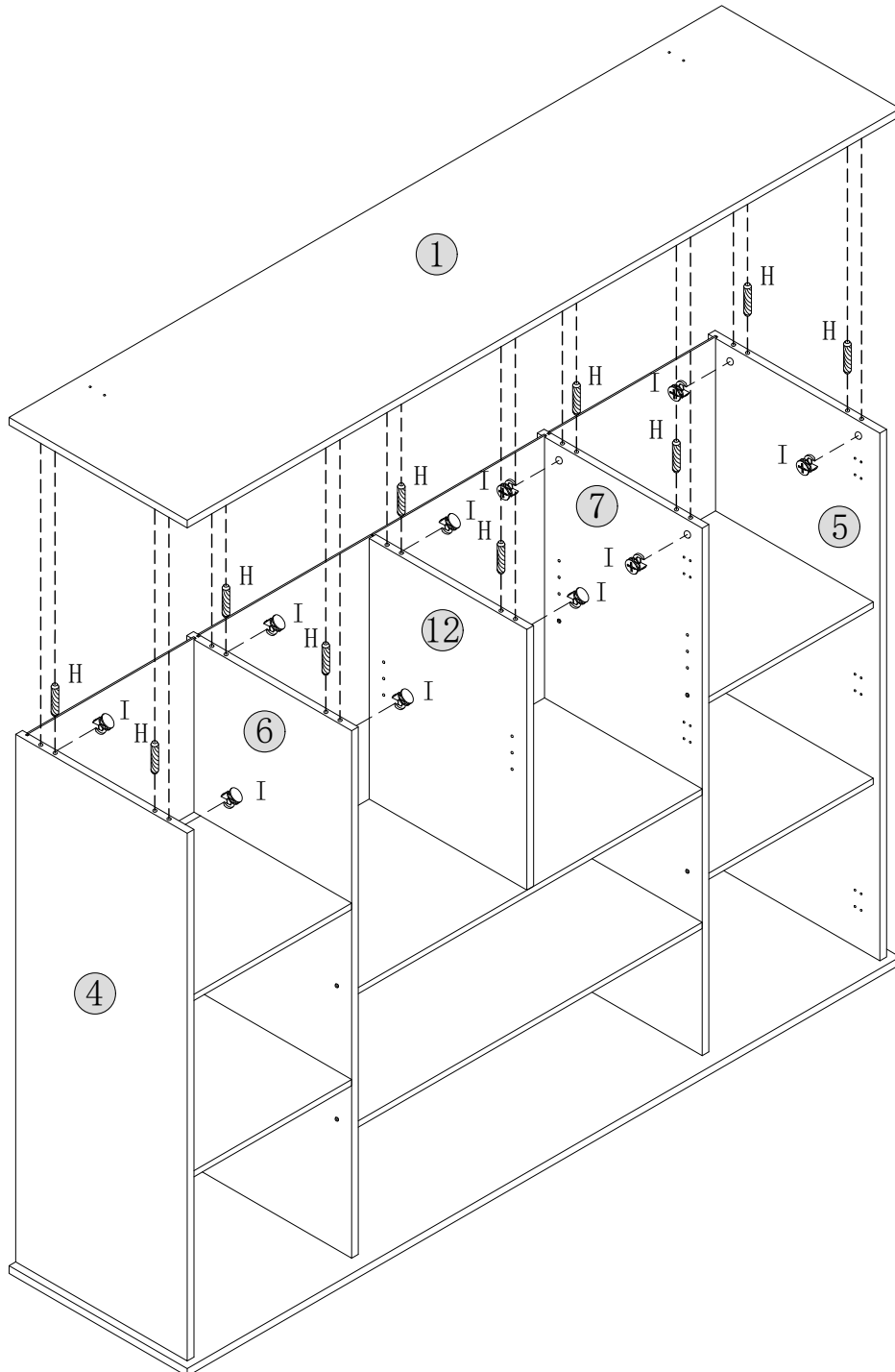



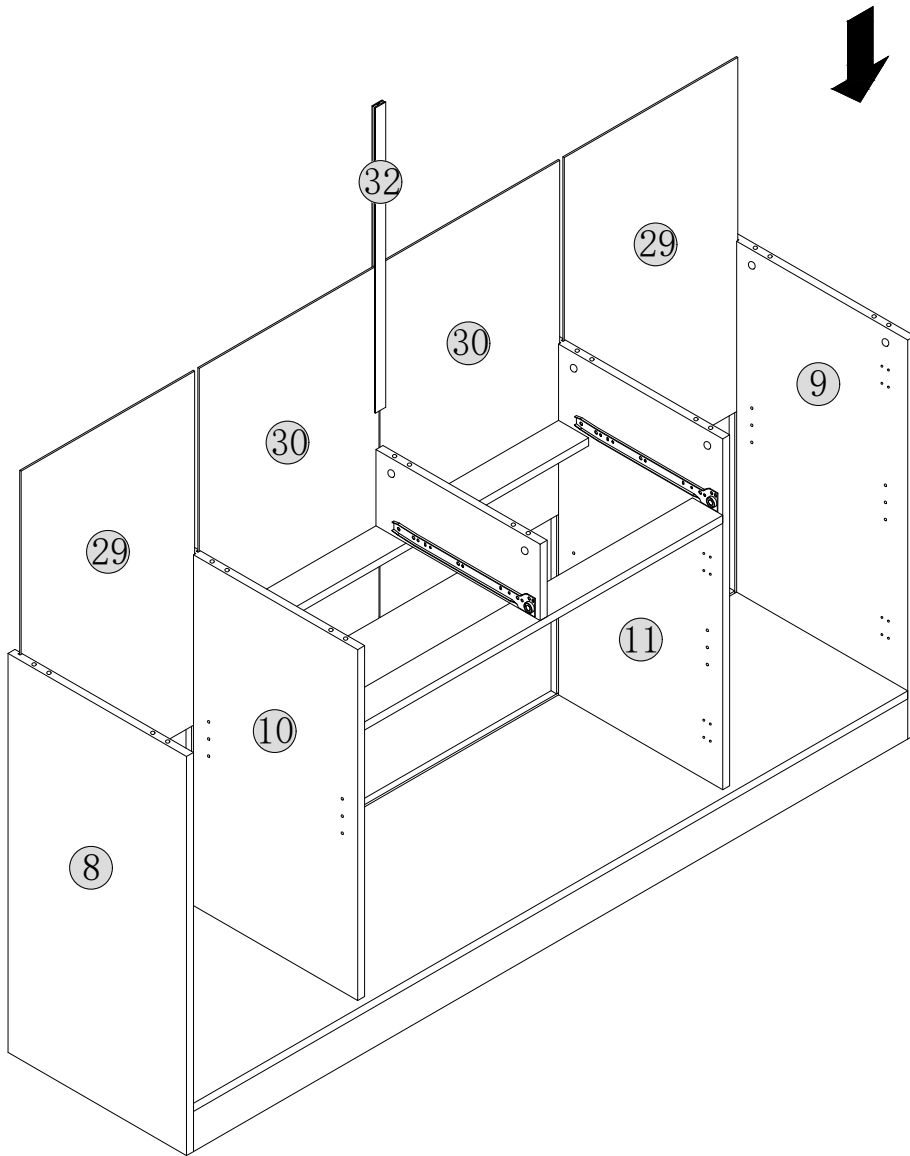

I × 10	H × 10
	
φ15 × 10mm	φ8 × 30mm

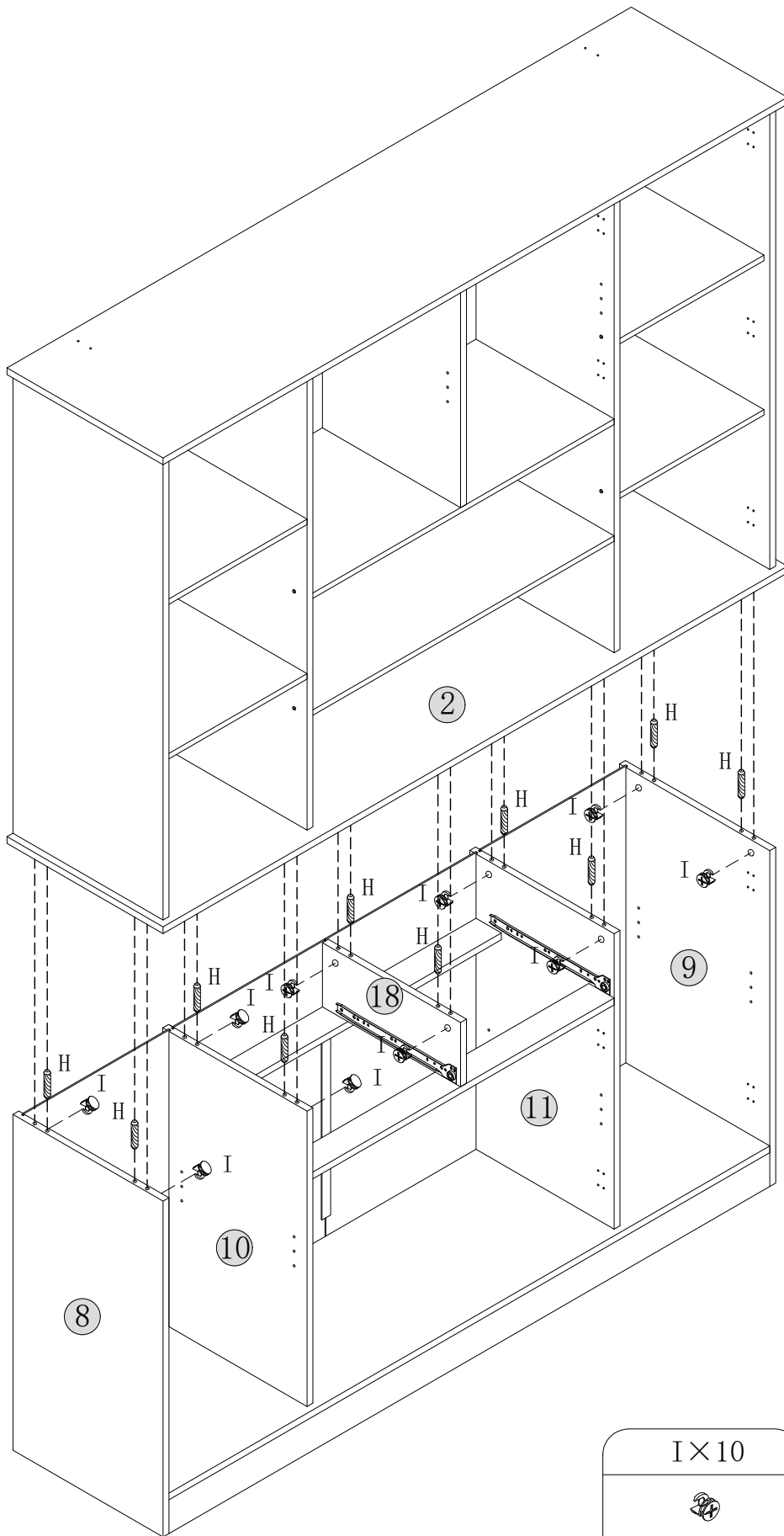



I × 10  φ15 × 10mm	H × 10  φ8 × 30mm
---	--

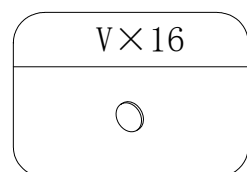
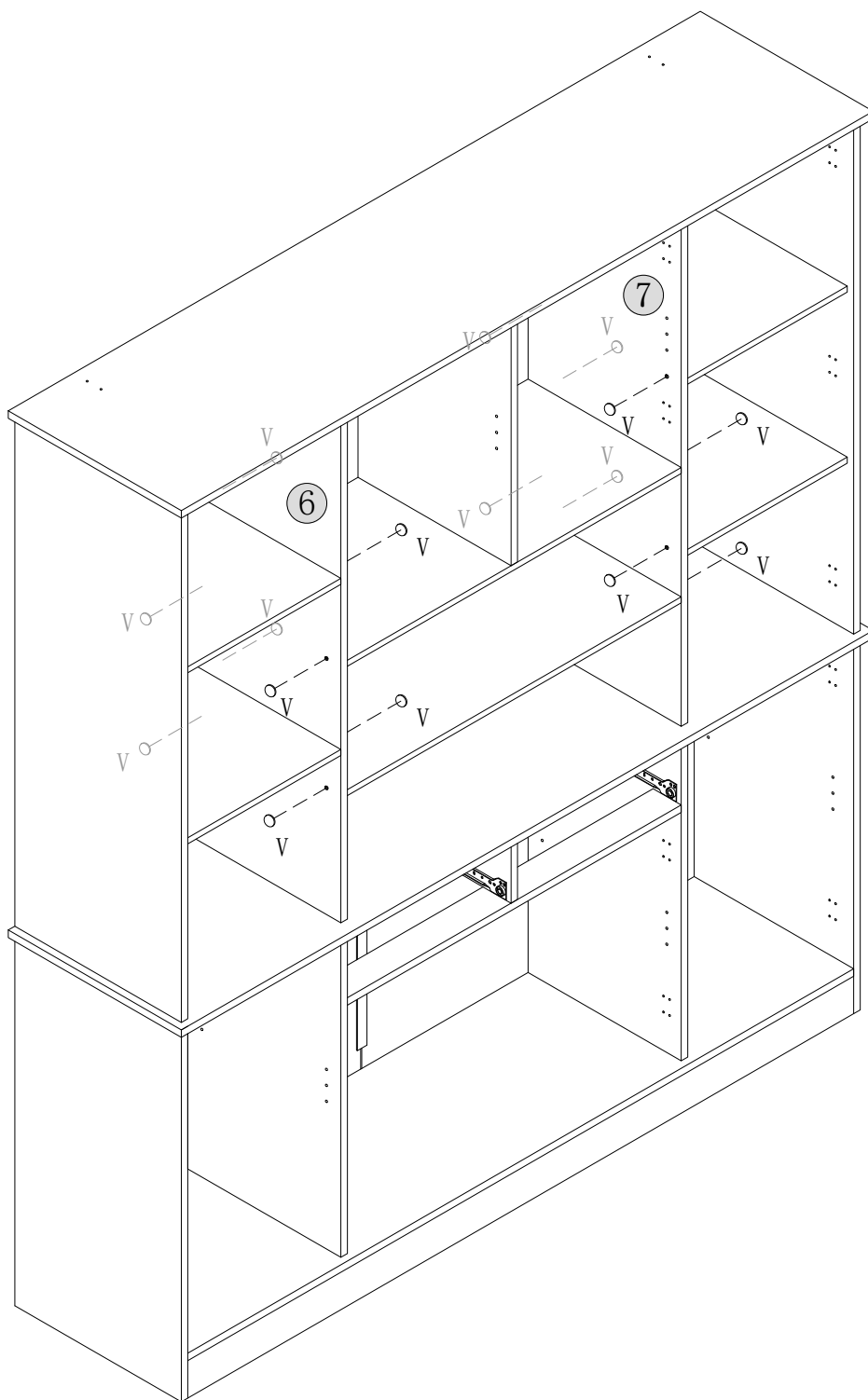

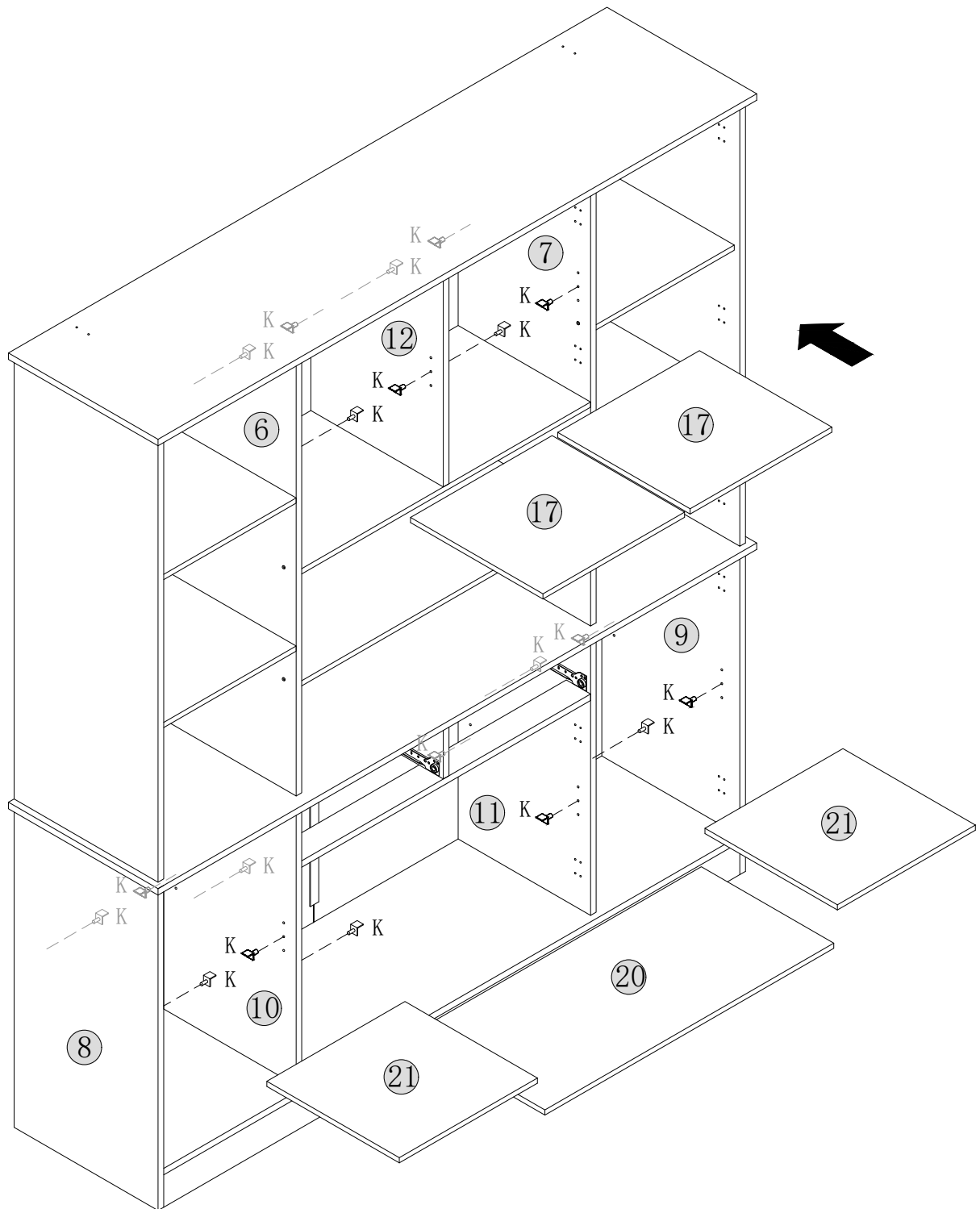

K × 20



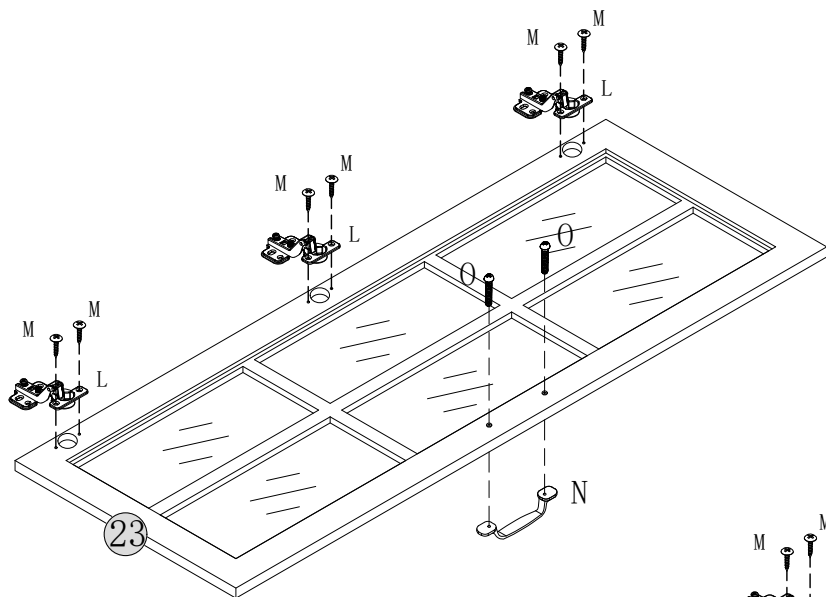

×2

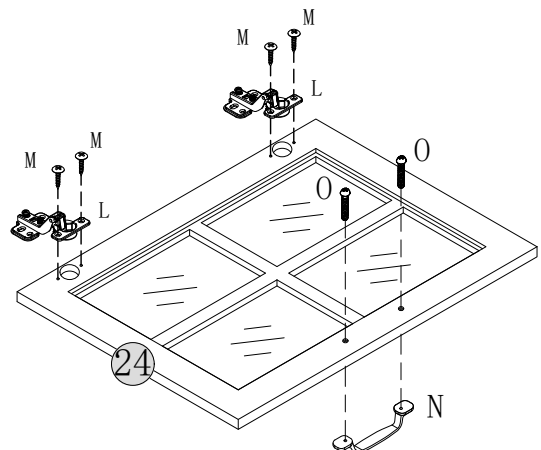



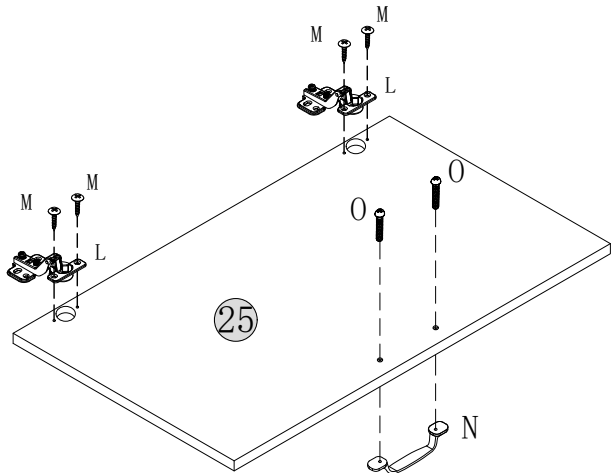

×2

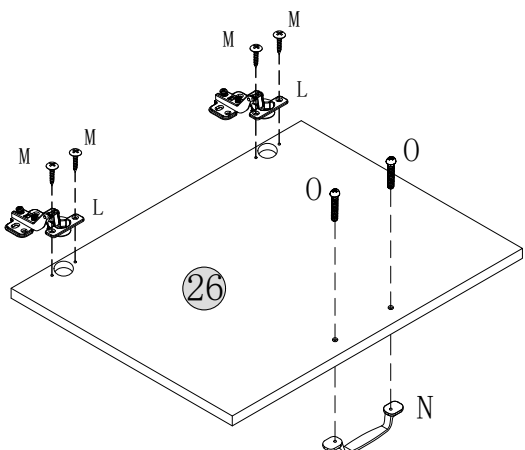

×2



×2

L × 18	M × 36	N × 8	O × 16
	 φ4 × 14mm		 φ4 × 18mm

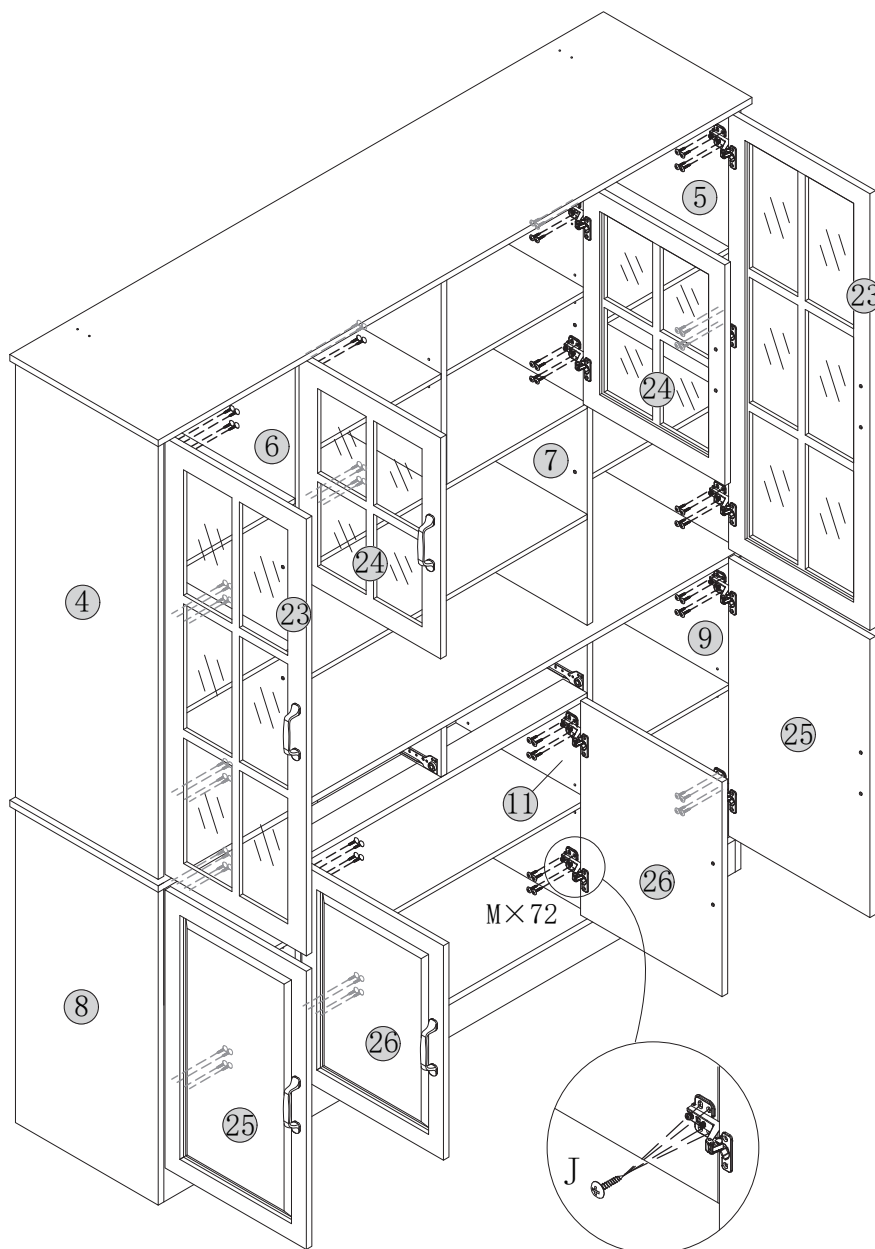

If the door can't close, please adjust the hinges.

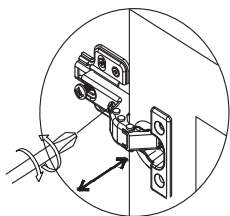

This is used to adjust the door panel in the up and down direction.

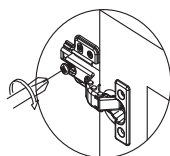
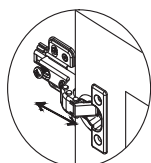
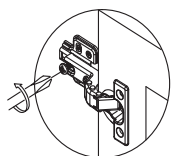

This is used to adjust the door panel in the front and back direction: Loosen the screw first, and then tighten screw after adjusting the door panel to the proper position.

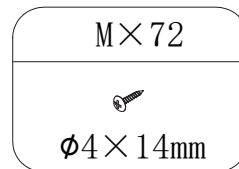

26

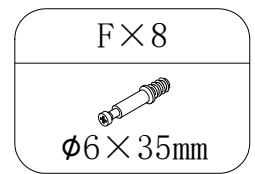
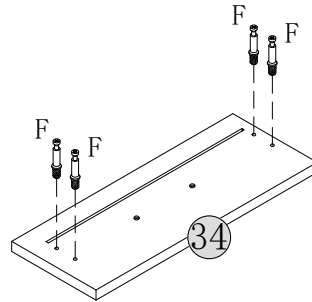
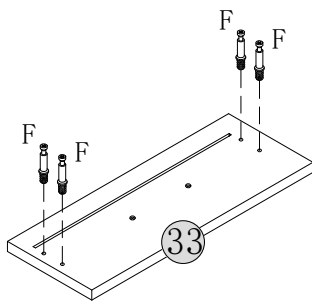

27

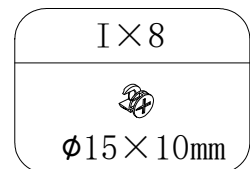
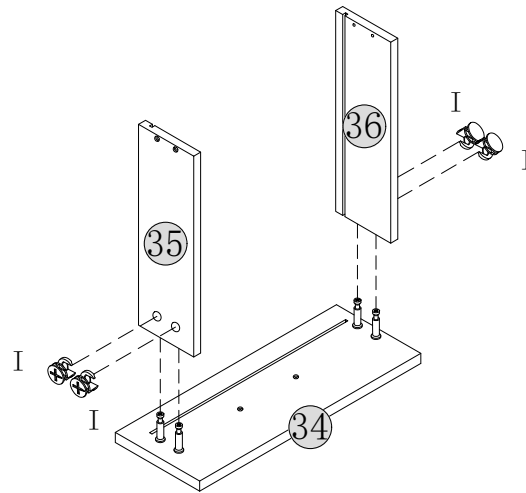
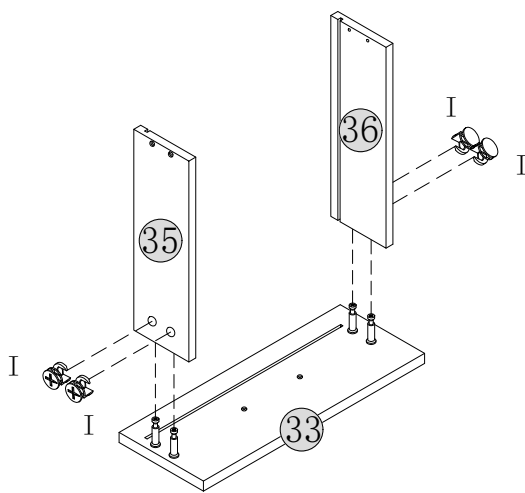

28

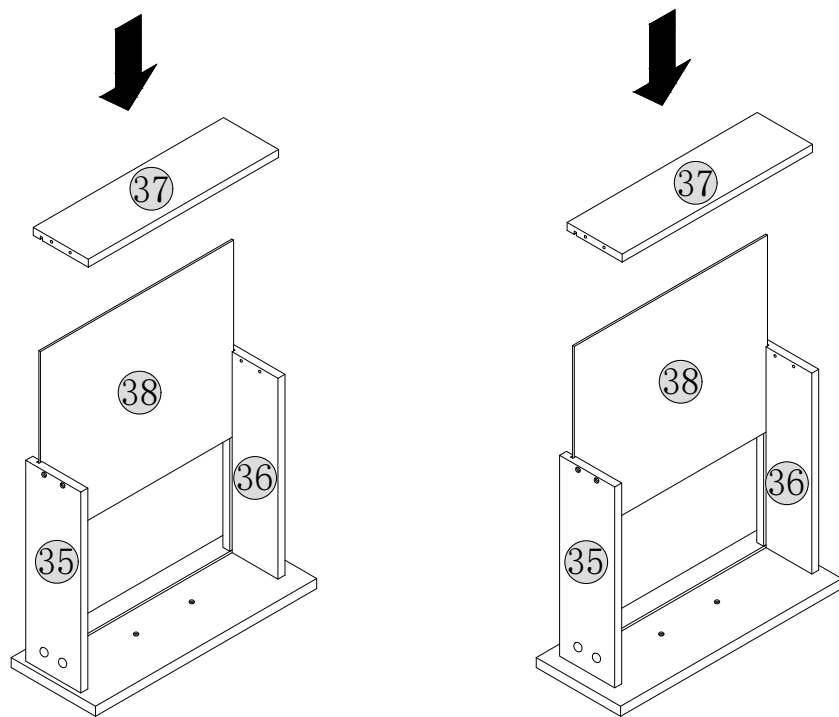

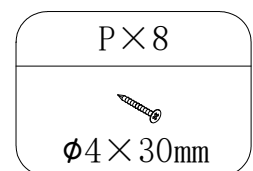
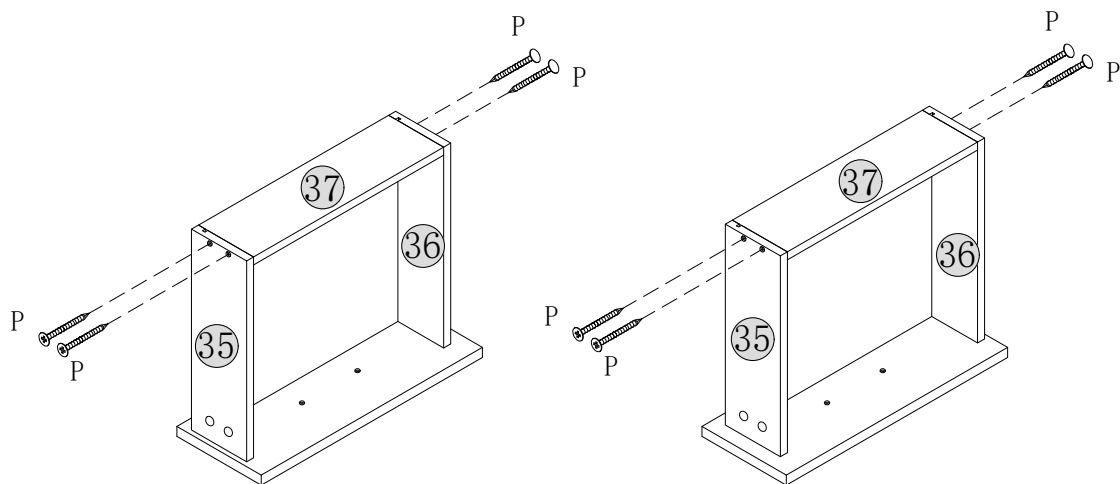

29



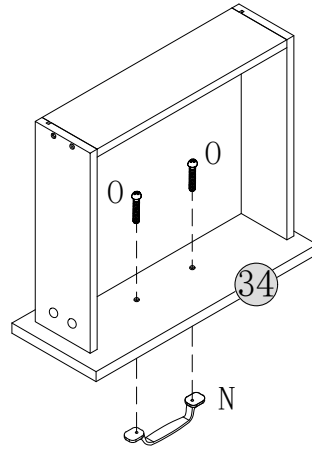
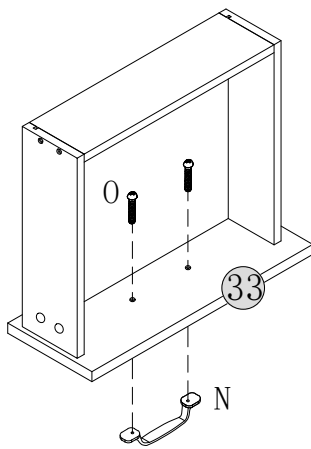

30

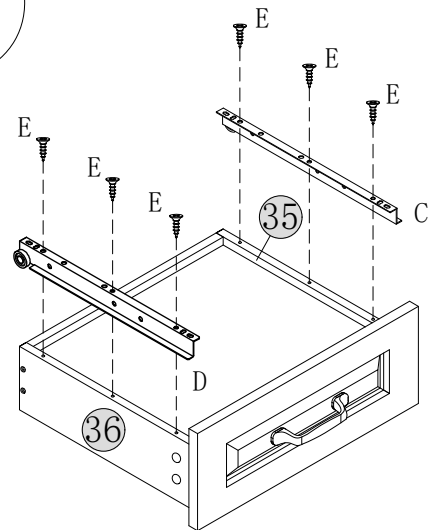
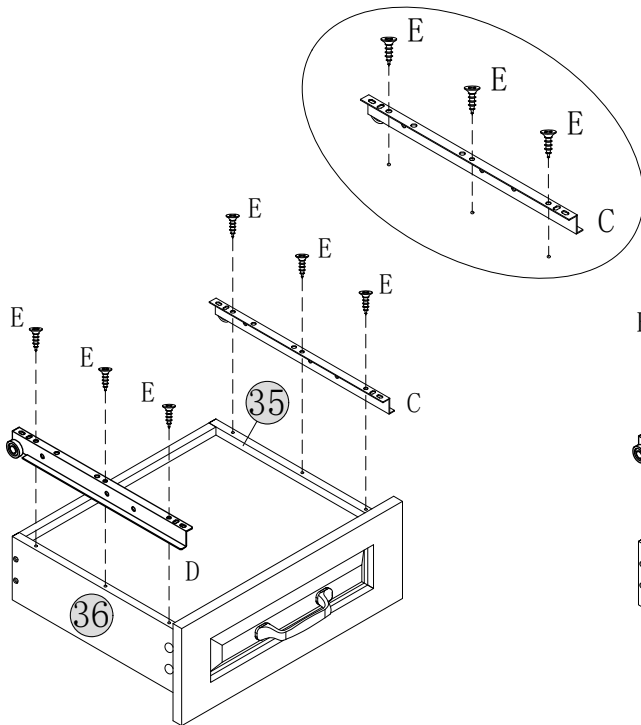

N×2	O×4
	
	∅4×18mm

31

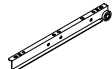
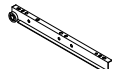

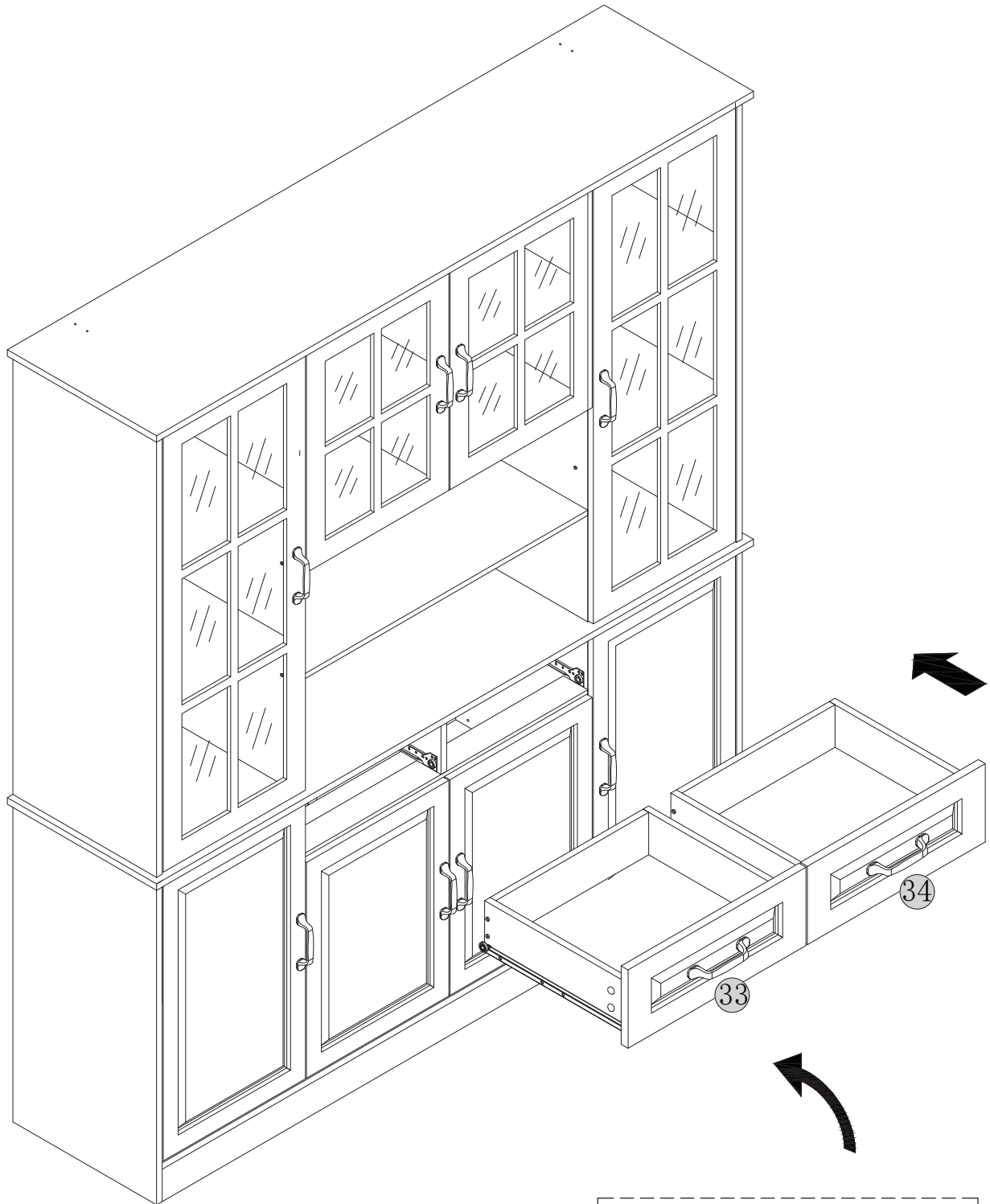

C×2	D×2	E×12
		
L 300mm	L 300mm	∅3×12mm

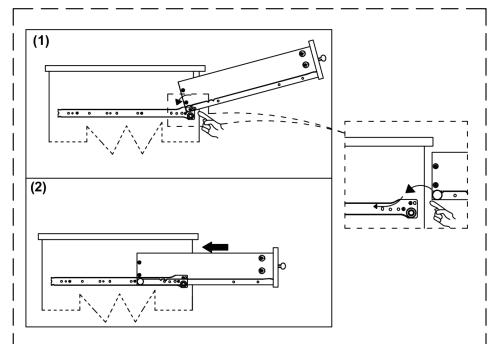

The wheels of the track have to be aligned and pushed along.

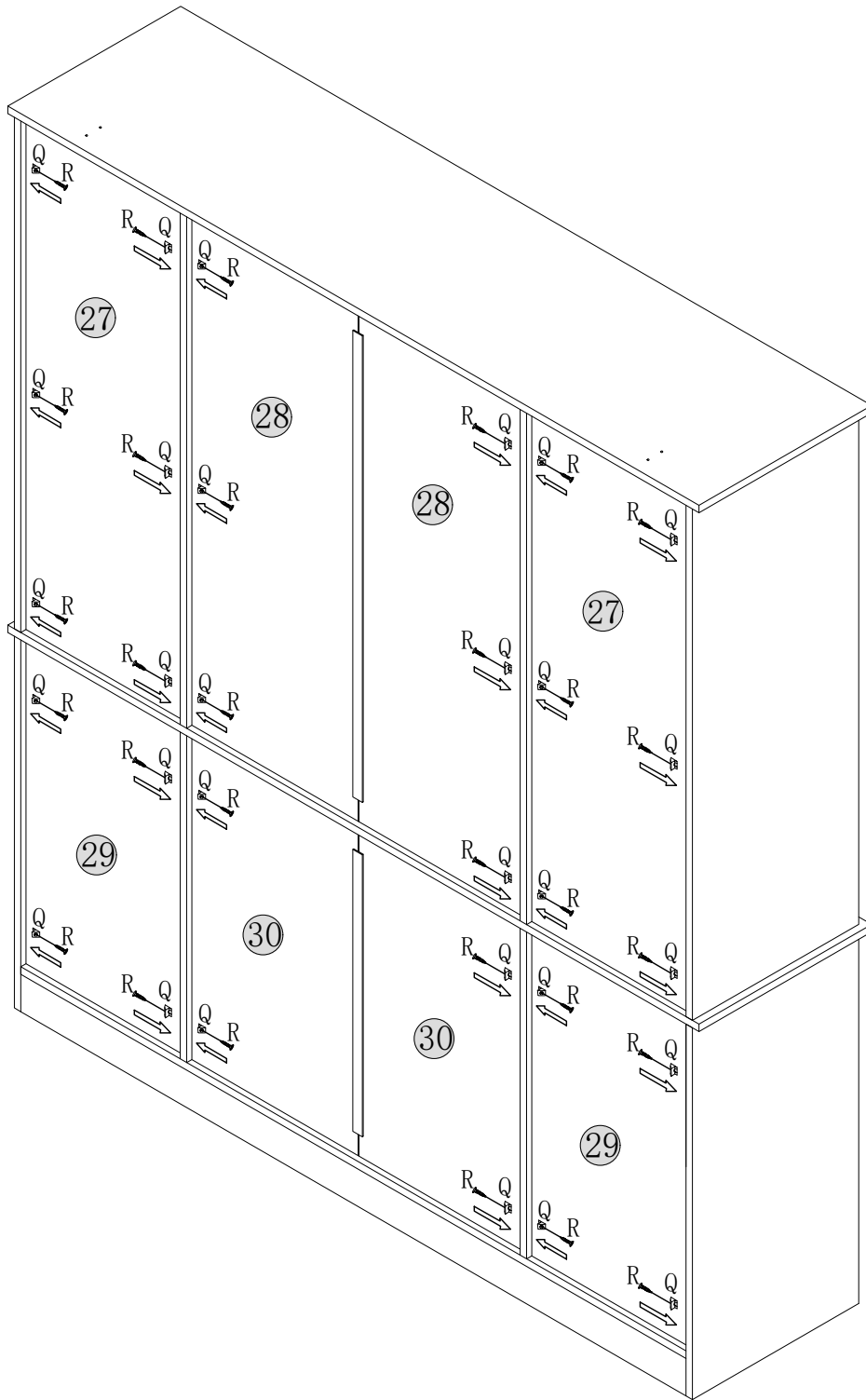



Q × 30	R × 30
	
	Ø3 × 14mm

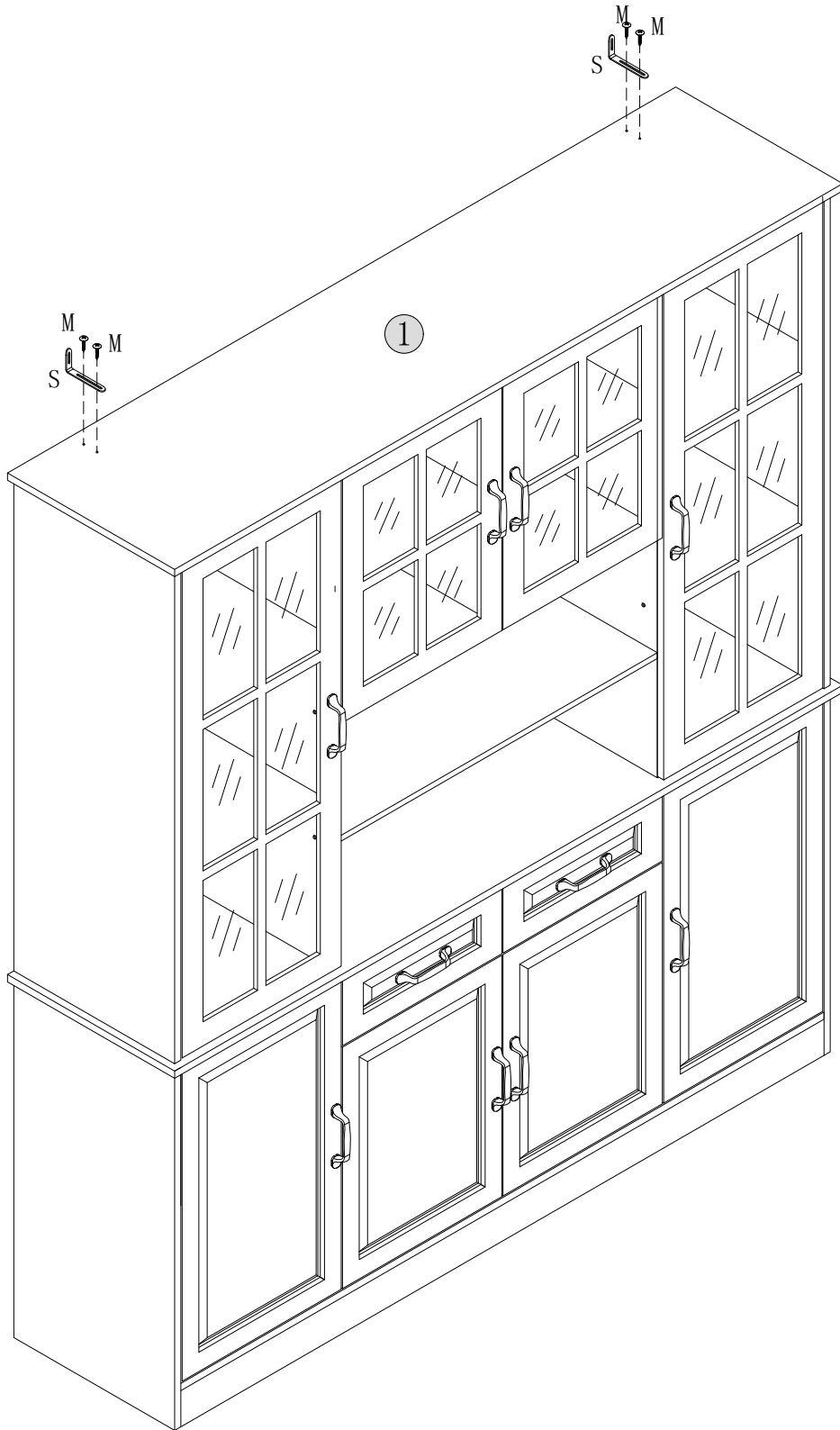

M×4



φ4×14mm

S×2



